



MODEL H0589 1/4" AIR DIE GRINDER INSTRUCTION SHEET





⚠ WARNING	
	EYE/EAR INJURY HAZARD! Wear safety glasses and hearing protection during use of this tool!
	INJURY HAZARD! Always disconnect tool from air to prevent unexpected operation during service!
	EXPLOSION HAZARD! Never exceed 90 PSI! Always use accessories with correct speed rating.
	RESPIRATORY HAZARD! Grinding produces fine dust. Wear the appropriate protection during use!



Figure 1. Model H0589.

Die Grinder MUST have 3-4 drops of oil directly dropped into the air fitting before each use as shown in **Figure 2**.

Introduction

No load speed is 20,000 RPM and collet size is 1/4". Requires maximum of 90 PSI with a minimum of 4 CFM compressor capacity. Air inlet is 1/4" and air exhaust is in the rear. Weighs 1.2 lbs.

Inventory

- A. Die Grinder 1
- B. Wrenches 2

Operation

Insert your 1/4" shank tool into the collet. Using the two wrenches, secure tool by tightening the collet nut against the spindle.

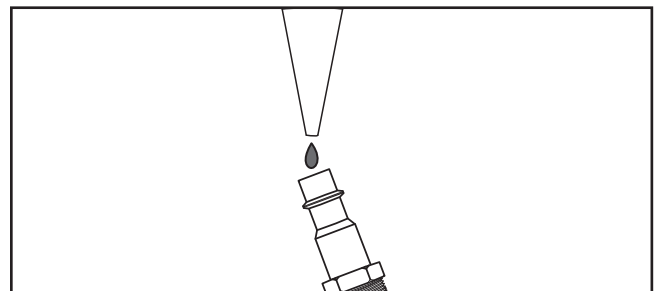
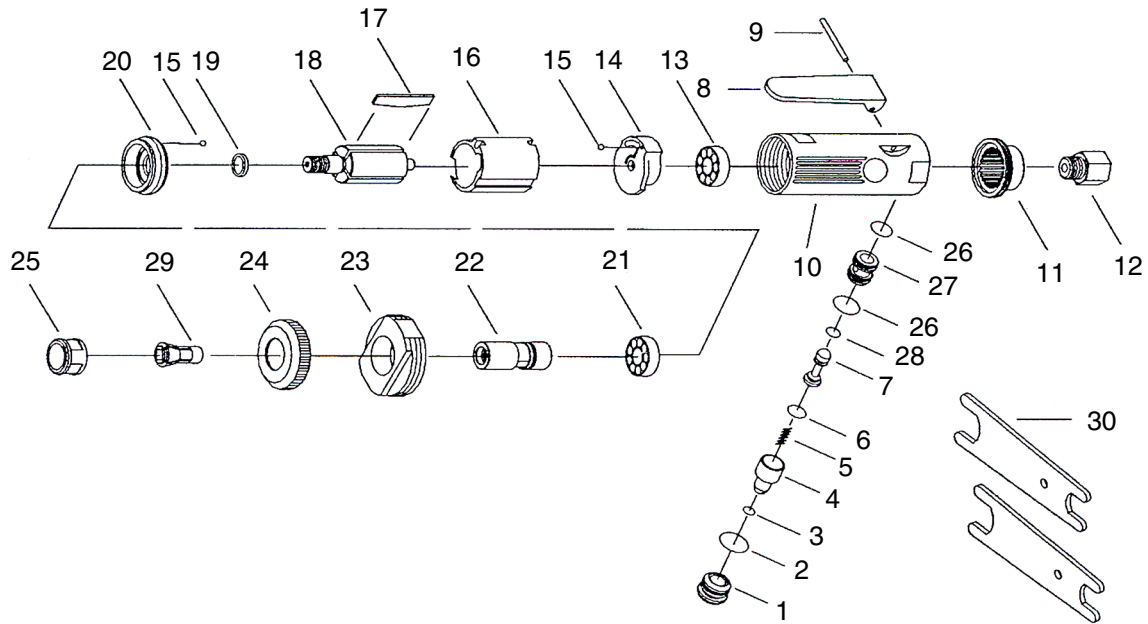

Figure 2. Lubricating directly into air fitting.

If you need help with your new pneumatic tool, call our Tech Support at: (570) 546-9663.

H0589 Parts Breakdown and List



REF	PART #	DESCRIPTION
1	PH0589001	VALVE SCREW
2	PH0589002	O-RING
3	PH0589003	O-RING
4	PH0589004	AIR REGULATOR STEM
5	PH0589005	COMPRESSION SPRING
6	PH0589006	O-RING
7	PH0589007	VALVE STEM
8	PH0589008	THROTTLE LEVER
9	PH0589009	LEVER PIN
10	PH0589010	MOTOR HOUSING
11	PH0589011	EXHAUST SLEEVE
12	PH0589012	AIR INLET
13	PH0589013	BALL BEARING
14	PH0589014	REAR PLATE
15	PH0589015	BALL

REF	PART #	DESCRIPTION
16	PH0589016	CYLINDER
17	PH0589017	ROTOR BLADE
18	PH0589018	ROTOR
19	PH0589019	BEARING SPACER
20	PH0589020	FRONT PLATE
21	PH0589021	BALL BEARING
22	PH0589022	SPINDLE
23	PH0589023	RETAINER
24	PH0589024	HOUSING CAP
25	PH0589025	COLLET NUT
26	PH0589026	O-RING
27	PH0589027	VALVE BUSHING
28	PH0589028	O-RING
29	PH0589029	1/4" COLLET
30	PH0589030	FLAT WRENCH 14/19