

MONDO STINGER 5.8

MST5.8

27dBm (500mw) 5.8GHz, A/V/D Transmitter

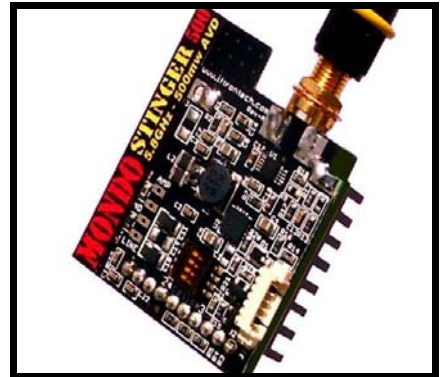

Introduction:

The Mondo Stinger 5.8 is an extremely compact microwave AV transmitter operating in the 5.8GHz frequency ISM band. Designed specifically to avoid interference from 2.4GHz radio sources such as WiFi, remote controls and other similar emissions, the Mondo Stinger 5.8 broadcasts NTSC or PAL/SECAM video plus two microphone and line-level audio/data channels. The Mondo Stinger 5.8 features a highly efficient on-board switching power supply for both the transmitter and our plug-in Universal Camera Power Supply - [UCPS](#) as well as an exclusive battery saver. Mondo Stinger 5.8 delivers ultra-wide video bandwidth for unrivaled video quality when paired with Iftron [YellowJacket Pro 5.8 Diversity*](#) or [Nano 5.8](#) Modular ultra wide band video receivers.

Considerable development has gone into the design of the Stinger 5.8 Pro. Please read this manual thoroughly so that you may better understand the features and operation.

Notice: This transmitter must be operated in accordance with applicable regulations

Features and General Information:

1. 7 channels from 5.740 to 5.860 GHz. (20 MHz channel spacing)
2. 500mw (27dBm +/- 1dBm) of output power.
3. Each Stinger 5.8 ships with a custom single-band 5.8 GHz whip antenna, marked with a **yellow ring** near the base.

Caution: Never operate this transmitter without an antenna rated for 5.8GHz or damage will occur.

- ***Do not** mistakenly use 2.4Ghz antennas with this transmitter! Other antennas may look the same but they are not the same inside.*
- ***Do not** remove the yellow ring because you will then be unable to tell the 5.8Ghz antennas from other antennas. (Ask us how we know).*
- ***Do not** use other antennas even if they claim to be 5.8GHz unless you are sure that they*

are not "dual band." Dual band antennas do not perform well.

4. Mondo Stinger 5.8 transmits 2 FM side channels: one for direct microphone use, the other for line level audio or medium speed serial data.
5. Mondo Stinger 5.8 features an exclusive ultra sensitive Automatic Level Controlled (ALC) microphone amplifier on the microphone audio channel.
6. To save weight and space, the audio inputs use solder pads that the user can solder to if they wish. The user must unsolder and remove the shorting resistor that is placed across the pads by the factory before using the input. This is easily done. A lectret microphone like most computer mics can be used, or an even a bare lectret microphone cartridge can be directly wired in. The sensitivity is unbelievable yet the mic will not saturate or clip with even the loudest sounds!
7. On-board switching power supply means very high efficiency and wide input voltage capability. The Stinger Pro runs on 6 volts to 15 volts with equal efficiency.
8. Exclusive power pilot LED resolves the question of whether the transmitter is getting power and is "on." The LED is on only when the switching power supply is functioning. This means that the LED is only on when the unit is properly powered and the input voltage meets the minimum voltage requirement as set by the **battery saver** selection switch. (See #10 below)
9. Reverse input voltage protected.
10. Exclusive 2 and 3 cell lipo battery saver. The dip switch should be set to 2 or 3 lipo cells. When the battery gets extremely low, the transmitter will stop transmitting and also shuts down power that goes out to the [UCPS](#) (Universal Camera Power Supply) if one is in use. Please note that when the battery saver is active, **there is still some small power drain** so the user must still disconnect the battery to avoid eventual battery damage.
11. Input power and video is via our included 6 pin wired connector. If you have purchased our optional [UCPS](#), this also ships with a compatible 6 pin connector that picks up power for the camera right from the transmitter and passes video back in.
12. These transmitters are heat sensitive and **should not** be wrapped in foam. The design has an integral cooling fin and heatsink that facilitates cooling. Airflow can greatly enhance performance and longevity. We encourage mounting the transmitter by a bracket that uses the SMA antenna connector as the mounting point so that air can circulate around the transmitter.
13. For airborne use, mount the transmitter with the antenna as low on the airframe as possible, to avoid any obstructions.
14. Lead free RoHS compliant construction is in accordance with European and emerging worldwide standards.

Applying Audio and Data to the Mondo Stinger 5.8 side channels:

Special note: All new Iftron products are RoHS lead free compliant and conform to existing European and worldwide standards for hazardous materials including lead.

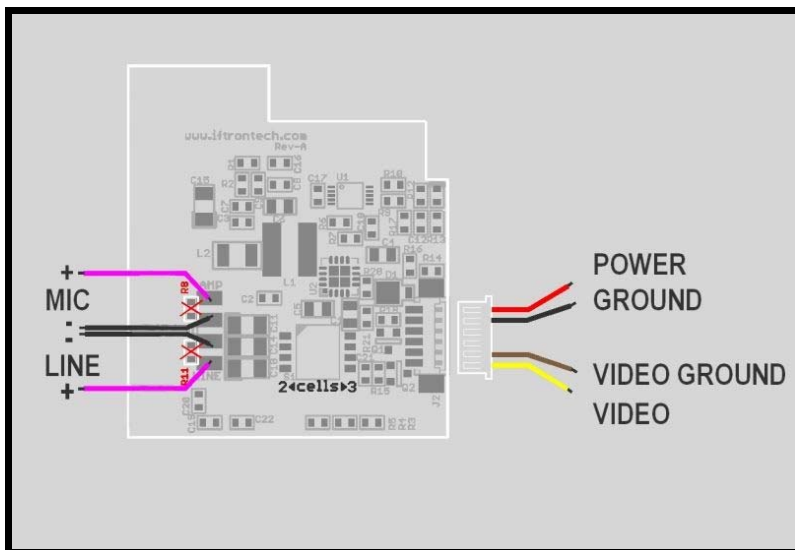

In order to save the weight and space, side channel signals can be soldered directly onto the circuit board. **You must** unsolder and remove R8 or R11 from the board to gain access to the desired input. **Do not** unsolder these parts until you are ready to use the associated input. This is easily accomplished with your soldering iron. Simply heat and remove the component. Now you may solder directly to the nearby pads. Note that the "MIC" pads provide direct "lectret" microphone support. This is by far, the most common microphone type and is in use on computers, headsets, etc. For the lightest and smallest applications, bare, lectret microphone cartridges are available from most electronics distributors and dealers. One example among many: [example lectret microphone](#).

Mondo Stinger 5.8 employs a highly sensitive, ALC (automatic Level Control) microphone amplifier on board. Amazingly, while capable of picking up a whisper at great distance, the amplifier will not overload even if you scream directly into it.

For line level audio or data input, use the lower pads marked "line." See specifications later in this document for more information. Note: Your receiver must be capable of receiving this second side channel. The Iftron YellowJacket Pro is compatible.

Mounting and Cooling:

Mondo Stinger 5.8 employs an exclusive, integral cooling fin and heatsink to aid in removal of excess heat. Buildup of excess heat will reduce the performance and life of this transmitter, thus we recommend that the transmitter not be wrapped in foam or otherwise insulated. Best performance can be achieved when mounted with a bracket using the SMA and included hardware as the mounting point in a manner that allows moving air to reach the transmitter.

Antenna Placement:

Placement of the antenna is important for best performance. Place the antenna such that no structures block the antenna from the receiving antenna. This is especially important if potential obstructions are made of metal or carbon fiber. If mounted on an aircraft, consider mounting the antenna low on the airframe and pointing down and to the rear by 30 degrees.

Battery Saver Operation:

Mondo Stinger 5.8 features an exclusive battery saver that helps prevent over-discharge of lipo batteries. The on-board #4 slide switch sets the saver to either 2 or 3 lipo cell operation. When properly set, the transmitter will shut down when the battery is nearly empty. If you are using our Universal Camera Power Supply (UCPS), the battery saver will also shut down the camera power. The on-board LED will also turn off as an indication that the battery is empty. Please note that some very small current will continue to flow when the battery gets too low. Thus, the battery should be disconnected to prevent eventual over-discharge.

Note: To inhibit operation of the battery saver, set the slide switch to '2 cells' and use a 3 cell battery.

Tuning:

Mondo & Stinger Pro Tuning			
Switch #			
Channel	1	2	3
1	ON	ON	ON
2	ON	ON	OFF
3	ON	OFF	ON
4	ON	OFF	OFF
5	OFF	ON	ON
6	OFF	ON	OFF
7	OFF	OFF	ON

Note: This chart also corresponds to the tuning switches on Nano 5.8 receivers.

Specifications:

Size:	W38 x H43.5 x T17 mm	Exclusive of connectors
Weight:	22g	
Input Voltage;	6-15VDC	Via input connector
Input Power:	2.8W at any input voltage	On-board switching supply
Video Input Level:	1VP-P 75ohms	Via input connector
Audio Ch1 Input Level:	User condenser microphone	Via solder pads
Audio Amplifier	Auto Level ALC hi-dynamic	
Audio/Data Ch2 Input Level:	Line .3V RMS (-10dBv)typ.	Via solder pads. Capable of audio or medium speed serial data
Output Frequencies:	5.740 – 5.860 GHz	
Channels:	7 channels – 20MHz spacing	Via dip switches #1-3 (binary code)
Output Power:	24dBm (250mw) +/- 1dBm 50ohms	Caution: Install antenna before powering on or damage will occur!
Antenna:	SMA 50 ohm connector	Iftron available antennas here
Battery Saver	Can be set to 2/3 lipo cells	Via dip switch #4

Iftron Technologies, Inc. reserves the right to make changes in product specifications without prior notice.

*** Learn more about Iftron's Patent Pending diversity technology here:**

<http://www.ifrontech.com/i6/information.html>

Copyright 2008 Iftron Technologies, Inc. All rights reserved.

Mondo Stinger 5.8, YellowJacket Pro, UCPS and Universal Camera Power Supply are copyright 2007-2009 Iftron technologies, Inc. All rights reserved.

www.ifrontech.com