

**Continental Disc[®]
Corporation**

3160 WEST HEARTLAND DRIVE LIBERTY, MISSOURI 64068-3385
PHONE: (816) 792-1500 FAX: (816) 792-2277 / 5447

BDI-FLX[™] 4W-NIS BURST DISC SENSOR SYSTEM OPERATOR'S MANUAL

IMPORTANT

USER SHOULD READ CAREFULLY AND UNDERSTAND
THIS MANUAL BEFORE INSTALLING, OPERATING OR
TESTING THIS UNIT

TABLE OF CONTENTS

I.	PRODUCT DESCRIPTION	3
II.	SPECIFICATIONS	4
III.	HANDLING AND UNPACKING	4
IV.	STORAGE	5
V.	INSTALLATION	5
VI.	MAINTENANCE	7
VII.	LIMITED WARRANTY	7
VIII.	DISCLAIMER OF WARRANTIES	8
IX.	DISCLAIMER OF CONSEQUENTIAL DAMAGES	8
X.	WARRANTY EXCLUSIONS	8

I. PRODUCT DESCRIPTION

WARNING: For full liquid applications: The BDI-FLX Sensor requires dynamic movement to signal. Slow reversal of the rupture disc, such as with liquid thermal expansion, will not cause the BDI-FLX Sensor to indicate. A small crack in a rupture disc score will not cause the BDI-FLX Sensor to indicate. Note that the BDI-FLX Sensor is designed to indicate within a few milliseconds, so full reversal and full opening of the rupture disc must occur within a few milliseconds. If full liquid flow at set pressure or a gas head will not be present during rupture of disc, contact CDC for evaluation.

The BDI-FLX Burst Disc Sensor Systems are designed to continuously monitor the status of rupture discs and output a switch signal to a system when such rupture discs have relieved an over-pressure condition. The system is comprised of two components: the BDI-FLX sensor and the BDI-FLX interface cable. The interface cable processes the sensor's signal and outputs a switch type signal.

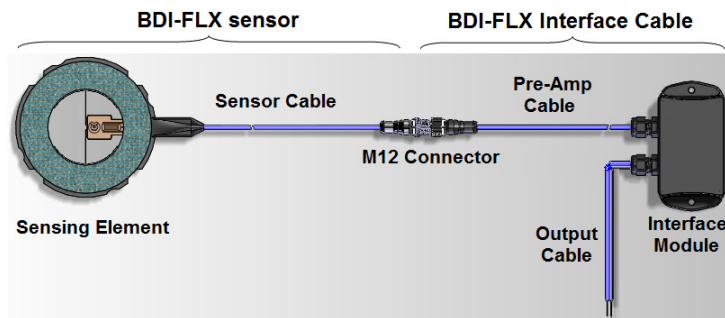

The BDI-FLX Burst Disc Sensor Systems contain numerous advances in rupture disc burst monitoring and alarm switching technology. Designed to meet the needs of a variety of applications and diverse industries, the BDI-FLX product family includes three models:

- BDI-FLX 2W-IS for use in hazardous environments and intrinsically safe applications
- BDI-FLX 2W-NIS for direct PLC or DCS discrete input
- BDI-FLX 4W-NIS for use as dry contact switch that can be used with a wide variety of power options and control/alarm inputs

This user manual provides detail specifications, electrical system requirements, wiring and operating instructions for model 4W-NIS.

The BDI-FLX 4W-NIS model is a 4-wire instrument: the power to the sensor system is on one pair of wires while a dry contact switch output is carried on the other pair of wires. External DC power in range of 6~28V is required for the sensor system to operate. A Single Pole Single Throw (SPST) Normally-Closed (NC) relay output signal offers the user a variety of switching power options and connections of control systems. The output contact is rated 3 VA maximum of switching power. It is suitable for most control system discrete inputs if separate power wiring is not an issue. Superior features include power isolated switch output, large switching capability for both DC and AC voltage thus fit for a wide variety of systems input such as PLC/DCS, interposing relay, alarming systems or actuator elements.

The interface cable contains a built-in microprocessor that processes the sensor signal and produces a logic output, offering plant operators a reliable rupture disc status signal. The interface cable incorporates a "failsafe" design: should there be a disc burst or an interruption of the sensor signal or power line, the output of the interface module is always switched automatically to the safe "OFF" condition.

II. SPECIFICATION



Electrical Specifications

Input Power:	6~28 VDC (including voltage fluctuation) Current consumption: 15 mA or less when contact closed.
Operating Temperature:	BDI-FLX Interface Cable -40°C to 70°C (-40°F to 158°F) BDI-FLX Sensor -40°C to 204°C (-40°F to 400°F)
Output configuration:	SPST Normally Closed (NC) reed relay dry contact Relay contact ratings: max. switching power: 3 VA; max switching voltage: 60 VDC or 30 VAC rms; max current: 250 mA
Power-up Time Delay:	62 ms
Polarity Protection:	Protected (up to 60 V)
Transient Over-voltage Protection:	Protected
Output Cable:	22 AWG, 2-STP PVC instrumentation cable, CM under UL-NEC

Mechanical Specifications

Housing Material:	ABS
Housing Inflammability Class:	UL 94 V-0
Housing Dimensions:	3.1 x 2.1 x 1.1 in. / 79 x 54 x 28 mm
Mounting:	Panel Mount
Cable Gland Material:	Nylon
Cable OD:	4.1 mm
Degree of Protection:	IP67

Regulatory Information:

	This product is designed and manufactured to comply with all applicable United States and Canadian safety requirements and is UL & cUL recognized. UL File no. E350819
	This product has been tested to the requirements of CAN/CSA-C22.2 No. 61010-1, second edition, including Amendment 1, or a later version of the same standard incorporating the same level of testing requirements.

III. HANDLING AND UNPACKING

The personnel responsible for the assembly, operation, inspection and maintenance of the BDI-FLX Burst Disc Sensor System must be appropriately qualified.

The BDI-FLX Burst Disc Sensor System is a precision device. Always follow these guidelines when handling and unpacking the product to prevent damage:

- A. Use care when unpacking/handling the product.
- B. Inspect the package for damage or missing items upon delivery.
- C. Mark any damage or missing items and report it to Customer Service at Continental Disc Corporation.

WARNING: POTENTIAL ELECTROSTATIC CHARGING HAZARD!
Precautions should be taken to reduce the risk of electrostatic charge. Prevent unintentional contact or cleaning with a dry cloth. Clean ONLY with a damp cloth. Do NOT use any solvent.

CAUTION: Always observe the applicable local standards, regulations and safety requirements. Failure to comply with required safety precautions may result in serious injury or damage to people/property/product and loss of all claims for damages.

IV. STORAGE

The BDI-FLX interface cable is to remain packed in the box in which it is shipped until ready for installation. This unit should be stored in a cool dry atmosphere with ambient temperatures within -40° C to +50° C (-40° F to +122° F).

V. INSTALLATION

WARNING: These installation and servicing instructions are for use by qualified personnel only. To avoid injury and electrical shock, do not perform any servicing other than that contained in this manual. The installation and wiring of this unit should be performed in accordance with the latest edition of the governing Electrical Code.

WARNING: Disconnect power to the unit before wiring.

NOTE: This section describes the procedures and requirements for connecting the BDI-FLX 4W-NIS interface cable to the user's system. For installation of the BDI-FLX sensor please refer to "Preparation and Installation of the BDI-FLX Sensor and Connection to the BDI-FLX Interface Cable Assembly" document provided with the BDI-FLX sensor.

1. The user must read carefully the installation procedure for the selected model and verify that their system meets the required conditions for the specific unit.
2. The BDI-FLX 4W-NIS System output is designed as Normally Closed (ON state) in the De-energize to Trip mode. Each time the unit is powered up, the output stays open (OFF state) for about 62 ms (power-up time delay) then switches ON. This warm-up period allows the power line to stabilize. User should examine their receiving system power-up set time for logic adaptation.
3. The BDI-FLX burst disc sensor system is designed for continuous monitoring of disc burst. When powering up on initial installation or upon restoring power from a lost power condition, the unit will reset itself automatically. When the BDI-FLX system trips an OFF signal as a result of a disc burst, the user should replace the rupture disc and BDI-FLX sensor. The user can reuse the interface cable. Re-powering the system without replacing the BDI-FLX sensor could result in a false normal (ON) signal.

WARNING: This unit is not designed/rated for hazardous environments.

WARNING: Do not connect the BDI-FLX 4W-NIS signal wires (white/green) directly to a power supply without a suitable load or current limiting device in series with the wire loop.

CAUTION: Lead polarity must be observed for the 4W-NIS power wires (red/black).

Operating Requirements:

The BDI-FLX 4W-NIS model is powered (through red/black wire pair) with 6~28 VDC supply and provides relay output—SPST normally closed (NC) dry contact signal (white/green wire pair).

Similar to a mechanical switch, the unit output can be connected to PLC or DCS discrete input, activate another interposing relay for remote bells, buzzers or lamps, and deactivate pumps, valves, etc. When connecting through an independent power source, the BDI-FLX 4W-NIS is able to switch various types of loads that carry wide power range.

When determining what devices can be driven by the BDI-FLX 4W-NIS output, the following limitations should not be exceeded.

Switching Contact Ratings: 3 VA maximum switching power
60 VDC or 30 VAC rms maximum switching voltage
250 mA maximum carry current

NOTE: “Normally Closed” relay output by the 4W-NIS model, as used in this manual, DOES NOT designate the shelf state of the relay. 4W-NIS ON state (normally closed) is designated as power on, non-alarm with internal relay energized and output contact closed. When 4W-NIS module is power off, the output contact is always OFF (open).

Wiring Diagram:

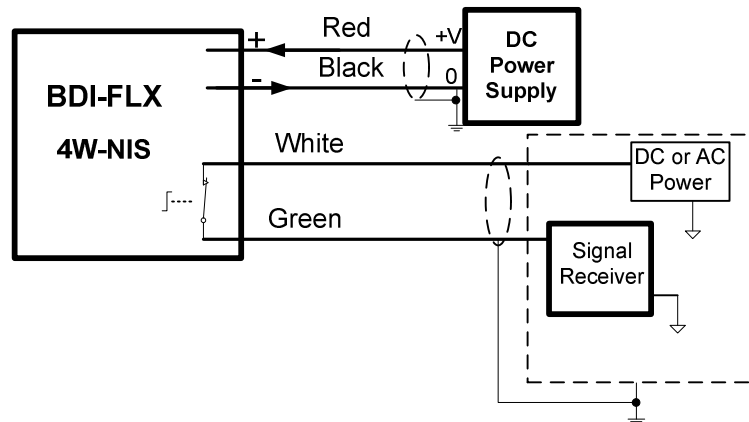

4W-NIS connected to separate power supply and signal receiving system

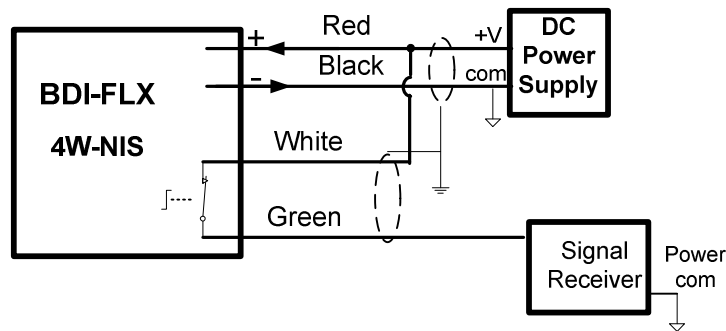

4W-NIS and signal receiving system sharing one DC power supply

(Note: When one DC power supply is used, the power supply must satisfy both BDI-FLX 4W-NIS input power requirement and user Signal Receiver power rating, as extreme within the voltage range of 6 ~ 28 VDC.)

Installation:

1. Mount the BDI-FLX Interface Cable Enclosure

Bolt the BDI-FLX interface cable enclosure to a panel rack using mounting bracket hardware. Consider the distance and location for convenient sensor connection.

2. Connect BDI-FLX Sensor to the BDI-FLX Interface Cable model 4W-NIS

Connect the BDI-FLX sensor to the BDI-FLX interface cable through the M12 connector. After insertion, fasten the M12 screw ring to lock the connection.

3. Connect Output Cable

Terminate the output cable power pair and signal pair to the appropriate terminals according to the wiring diagram. Terminate all other correlated wires and ground properly before operation.

4. Final Check

Check all wiring to ensure proper connections with no unwanted possible shorts, grounds, or open circuits.

5. Energize Power to Unit

With the disc, sensor system, power supply and output load installed and properly connected the unit can be powered and ready for operation.

VI. MAINTENANCE

The BDI-FLX interface cables have been designed to operate with little maintenance required. Periodic checks should be made to ensure the units are clean and free from contaminating, humid or hot atmospheres, and are in good physical and electrical condition.

NOTE: The shelf contact position (i.e., relay coil de-energized) is OPEN. Periodic inspection should be given to the contact position when no power is supplied to the 4W-NIS. If a closed contact is detected, the interface cable is out of operation and must be replaced.

Should the system fail to function properly, the user should check for the following items where applicable:

- A. All specified conditions of the connected system listed in [Section V](#) are met.
- B. The unit is connected to the power supply in the correct polarity.
- C. There is no ground loop through the cable signal transmission.
- D. The BDI-FLX sensor has been properly connected to the interface cable prior to powering the unit.
- E. The power is on.
- F. All wiring is connected properly per this instruction manual.
- G. The connected terminal blocks or input channels are working properly.
- H. The user receiving system (PLC/DCS, relay etc.) is functioning properly.
- I. There is no short or open circuit in the disc sensor, interface cable or connectors.
- J. The disc and sensor are in good condition.

Note: If the sensor has tripped an OFF signal due to disc burst or signal interruption, the system needs to be reset following instructions listed in [Section V](#).

The BDI-FLX interface modules are designed with industrial category components and every effort has been made to make the unit as easily serviceable as possible. Should there be a problem before or during operation please contact Continental Disc Corporation Customer Service for assistance. Do not repair or modify the product without consultation of Continental Disc Corporation. Disassembly of the unit and/or replacement of components may lead to improper function of the system and safety hazards.

VII. LIMITED WARRANTY

Products manufactured by Continental Disc Corporation have a warranty against defective workmanship and material for a period of one year after date of invoice. In no event shall Continental Disc Corporation's liability for damages with respect to any of the products furnished under this Agreement exceed the charges previously paid by the customer to Continental Disc Corporation for such products. Buyer's sole remedy for breach of this Agreement is repair or replacement of defective parts furnished by Continental Disc Corporation, which have been returned to Continental Disc Corporation's factory at purchaser's expense. It is expressly agreed between purchaser and Continental Disc Corporation that the remedy of repair and replacement is the exclusive and sole remedy of the purchaser.

VIII. DISCLAIMER OF WARRANTIES

Except as specifically provided in this Agreement, there are no warranties, expressed or implied, including, but not limited to any implied warranties of merchantability or fitness for a particular purpose.

IX. DISCLAIMER OF CONSEQUENTIAL DAMAGES

In no event shall Continental Disc Corporation be liable for consequential damages, including but not limited to damages for loss of use, damages for lost profits, and damages for resulting harm to property other than the Continental Disc Corporation assemblies and their component parts.

Customer acknowledges and understands that the provisions of these additional terms and conditions, including this paragraph concerning disclaimer of consequential damages and limitation or remedy, apply fully to the purchase of the products.

X. WARRANTY EXCLUSIONS

This warranty does not apply in the event of misuse or abuse of the product or as a result of unauthorized alterations or repairs.