



SCM Microsystems

Reference Manual – version 1.5



SCL3711

Multiprotocol contactless mobile reader

Reference manual

SCL3711 Multiprotocol Contactless mobile Reader

© SCM Microsystems
Oskar-Messter-Strasse, 13
85737 Ismaning
Germany

Phone +49 89 9595 5000 • Fax +49 89 9595 5555

Document history

Date	Version	Description of change
16/02/2009	1.0	Initial version
06/03/2009	1.1	Review and update by product management
18/03/2009	1.2	Final review for release
01/04/2009	1.3	Update – added examples of APDU sequences for a few commands + corrected a few typos
01/04/2009	1.4	Updates related to Driver version 1.04
29/10/2009	1.5	Updates related to Driver version 1.06 <ul style="list-style-type: none">• Various editorial changes• Installation procedure chapter updated• Addition of T=CL user command description (§6.1.3)• Addition of FELICA_PASSTHROUGH escape (§6.6.10)

Contact information

<http://www.scmmicro.com/products-services/smart-card-readers-terminals/contactless-dual-interface-readers.html>

For sales information, please email sales@scmmicro.com

Table of Contents

1.	Legal information	7
1.1.	Disclaimers.....	7
1.2.	Licenses	7
1.3.	Trademarks	7
2.	Introduction to the manual	8
2.1.	Objective of the manual	8
2.2.	Target audience	8
2.3.	Product version corresponding to the manual	8
2.4.	Definition of various terms and acronyms	9
2.5.	References	10
2.6.	Conventions	11
3.	General information about SCL3711	12
3.1.	SCL3711 key benefits	12
3.2.	SCL3711 key features.....	12
3.3.	SCL3711 ordering information	13
3.4.	SCL3711 customization options.....	13
3.5.	Contactless communication principles and SCL3711 usage recommendations	14
3.5.1.	Power supply.....	14
3.5.2.	Data exchange.....	14
3.5.3.	Recommendations	15
3.6.	Applications	16
3.6.1.	General	16
3.6.2.	Applications provided by SCM Microsystems.....	16
4.	SCL3711 characteristics.....	17
4.1.	SCL3711 high level architecture	17
4.1.1.	Block diagram	17
4.1.2.	Software architecture	17
4.2.	Quick reference data.....	18
4.2.1.	SCL3711 dimensions.....	18
4.2.2.	LED behavior	18
4.2.3.	Other data	18
5.	Software modules	20
5.1.	Installation	20
5.1.1.	Command line parameters for installation	21
5.1.2.	Command line parameters for un-installation.....	21
5.2.	Utilities.....	21
5.3.	Driver.....	22
5.3.1.	SCL3711 listing.....	22
5.3.2.	Supported operating systems	22
5.3.3.	PC/SC 2.0 compliant ATR	23
5.4.	Firmware	28

5.4.1.	Transport protocol.....	28
5.4.2.	Automatic PPS.....	28
6.	Commands description.....	29
6.1.	Generic APDUs.....	29
6.1.1.	Get UID Command.....	29
6.1.2.	Get DATA Command.....	30
6.1.3.	T=CL user Command.....	31
6.1.4.	PASS_THROUGH command.....	32
6.2.	Set of APDU for contactless storage user tokens.....	33
6.2.1.	STORAGE_CARD_CMDS_READ_BINARY.....	33
6.2.2.	STORAGE_CARD_CMDS_WRITE_BINARY.....	35
6.2.3.	STORAGE_CARD_CMDS_LOAD_KEYS.....	37
6.2.4.	STORAGE_CARD_CMDS_AUTHENTICATE.....	38
6.2.5.	STORAGE_CARD_CMDS_VALUE_BLOCK.....	40
6.3.	Set of APDU for ISO/IEC 14443-4 user tokens.....	41
6.3.1.	T=CL Command.....	41
6.4.	MIFARE DESFire commands.....	42
6.5.	Set of APDU defined by SCM Microsystems.....	42
6.5.1.	Commands for communicating with NFC Forum Tags Type 1.....	42
6.5.2.	Commands for communicating with NFC Forum Tags Type 2.....	48
6.5.3.	Commands for communication with NFC Forum Tags Type 3.....	48
6.5.4.	Commands for communicating with NFC Forum Tags Type 4.....	50
6.6.	Escape IOCTL's supported in SCL3711.....	51
6.6.1.	READER_CNTLESS_GET_ATS_ATQB.....	51
6.6.2.	READER_GET_CARD_TYPE_POLLING.....	52
6.6.3.	READER_CNTLESS_SET_TYPE.....	52
6.6.4.	READER_CNTLESS_RF_SWITCH.....	53
6.6.5.	READER_CNTLESS_DISABLE_PPS.....	53
6.6.6.	READER_ENABLE_DISABLE_848.....	54
6.6.7.	READER_CNTLESS_BAUDRATE.....	54
6.6.8.	READER_FORCE_BAUDRATE.....	55
6.6.9.	READER_DISABLE_NAK_POLLING.....	56
6.6.10.	FELICA_PASSTHROUGH.....	56
7.	Annexes.....	57
7.1.	Annex A.....	57
7.1.1.	Status words table.....	57
7.1.2.	Further information about PC/SC.....	57
7.2.	Annex B – Mechanical drawings.....	58

1. Legal information

1.1. Disclaimers

The content published in this document is believed to be accurate. SCM Microsystems does not, however, provide any representation or warranty regarding the accuracy or completeness of its content and regarding the consequences of the use of information contained herein. If this document has the status "Draft", its content is still under internal review and yet to be formally validated.

SCM Microsystems reserves the right to change the content of this document without prior notice. The content of this document supersedes the content of previous versions of the same document. The document may contain application descriptions and/or source code examples, which are for illustrative purposes only. SCM Microsystems gives no representation or warranty that such descriptions or examples are suitable for the application that the reader may want to use them for.

Should you notice problems with the provided documentation, please provide your feedback to support@scmmicro.com.

1.2. Licenses

If the document contains source code examples, they are provided for illustrative purposes only and subject to the following restrictions:

- You MAY at your own risk use or modify the source code provided in the document in applications you may develop. You MAY distribute those applications ONLY in form of compiled applications.
- You MAY NOT copy or distribute parts of or the entire source code without prior written consent from SCM Microsystems.
- You MAY NOT combine or distribute the source code provided with Open Source Software or with software developed using Open Source Software in a manner that subjects the source code or any portion thereof to any license obligations of such Open Source Software.

If the document contains technical drawings related to SCM Microsystems products, they are provided for documentation purposes only. SCM Microsystems does not grant you any license to its designs.

1.3. Trademarks

MIFARE is a registered trademark of NXP Semiconductors BV.

FeliCa is a registered trademark of Sony Corporation.

Jewel and Topaz are trademarks of Innovision Research and Technology Plc.

Windows is a registered trademark of Microsoft Corporation

2. Introduction to the manual

2.1. Objective of the manual

This manual provides an overview of the hardware and software features of the SCL3711 multiprotocol mobile contactless reader, hereafter referred to as "SCL3711".

This manual describes in details interfaces and supported commands available for developers using SCL3711 in their applications.

2.2. Target audience

This document describes the technical implementation of SCL3711.

The manual targets software developers. It assumes knowledge about 13.56 MHz contactless technologies like ISO/IEC 14443 and commonly used engineering terms.

Should you have questions, you may send them to support@scnmicro.com.

2.3. Product version corresponding to the manual

Item	Version
Hardware	0.2
Firmware	2.7.0
Driver	1.06
Installer	1.04

2.4. Definition of various terms and acronyms

Term	Expansion
APDU	Application Protocol Data Unit
ATR	Answer to Reset, defined in ISO7816
ATS	Answer to Select, defined in ISO14443
Byte	Group of 8 bits
CCID	Chip Card Interface Device
CID	Card Identifier
CL	Contactless
CLA	Class byte defined in ISO 7816
DFU	Device Firmware Upgrade
FeliCa™	Sony contactless technology standardized in ISO18092, technology underlying the NFC Forum tag type 3
INS	Instruction byte defined in ISO7816
Jewel/Topaz	Innovision contactless technology, technology underlying the NFC Forum tag type 1
LED	Light emitting diode
MIFARE	The ISO14443 Type A with extensions for security (NXP)
NA	Not applicable
NAD	Node Address
NDEF	NFC Data Exchange Format: data structure defined by the NFC Forum for NFC Forum tags.
NFC	Near Field Communication
Nibble	Group of 4 bits. 1 digit of the hexadecimal representation of a byte. <i>Example:</i> 0xA3 is represented in binary as (10100011) _b . The least significant nibble is 0x3 or (0011) _b and the most significant nibble is 0xA or (1010) _b
P2P	Peer – to – Peer
PCD	Proximity Coupling Device
PC/SC	Personal Computer/Smart Card: software interface to communicate between a PC and a smart card
PICC	Proximity Integrated Chip Card
PID	Product ID
PPS	Protocol Parameter Selection
Proximity	Distance coverage till ~10 cm.
PUPI	Pseudo unique PICC identifier
RFU	Reserved for future use
RF	Radio Frequency
STC3	Smart card reader controller ASIC from SCM Microsystems
SW1 SW2	Status word defined in ISO7816
USB	Universal Serial Bus
VID	Vendor ID
(xyz) _b	Binary notation of a number x, y, z ∈ {0,1}
0xYY	The byte value YY is represented in hexadecimal

2.5. References

Doc ref in the manual	Description	Issuer
ISO/IEC 7816-4	Identification cards - Integrated circuit(s) cards with contacts Part 4: Interindustry commands for interchange ISO/IEC 7816-4: 1995 (E)	ISO / IEC
ISO/IEC 14443-4	Identification cards — Contactless integrated circuit(s) cards — Proximity cards Part 4: Transmission protocol ISO/IEC 14443-4:2001(E)	ISO / IEC
ISO/IEC 18092	Information technology — Telecommunications and information exchange between systems — Near Field Communication — Interface and Protocol (NFCIP-1) ISO/IEC 18092:2004(E)	ISO / IEC
NFC Forum tag type 1	NFCForum-TS-Type-1-Tag_1.0	NFC Forum
NFC Forum tag type 2	NFCForum-TS-Type-2-Tag_1.0	NFC Forum
NFC Forum tag type 3	NFCForum-TS-Type-3-Tag_1.0	NFC Forum
NFC Forum tag type 4	NFCForum-TS-Type-4-Tag_1.0	NFC Forum
PC/SC	Interoperability Specification for ICCs and Personal Computer Systems v2.01	PC/SC Workgroup
NFC wrapper	User manual of the NFC wrapper. This manual is part of SCM's Contactless SDK.	SCM Microsystems
CCID	Specification for Integrated Circuit(s) Cards Interface Devices 1.1	USB-IF
USB	Universal Serial Bus Specification 2.0	USB-IF

2.6. Conventions

Bits are represented by lower case 'b' where followed by a numbering digit.

Bytes are represented by upper case 'B' where followed by a numbering digit.

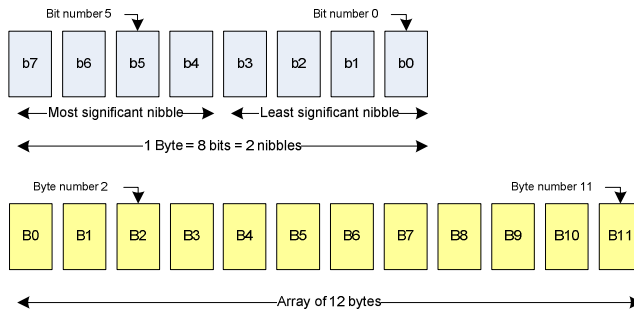

Example:

163 in decimal is represented

- in hexadecimal as 0xA3
- in binary as (10100011)b

The least significant nibble of 0xA3 is

- 0x3 in hexadecimal
- (0011)b in binary

The most significant nibble of =xA3 is

- 0xA in hexadecimal
- (1010)b in binary

3. General information about SCL3711

3.1. SCL3711 key benefits

With its functional solid mechanical design that has no removable parts that you may lose, SCL3711 is perfect for mobile uses.

While being slim, SCL3711 dimensions have been optimized to ensure best RF performance possible with such a form factor.



The state of the art multi-protocol feature set of SCL3711 qualifies it to be used in a wide range of applications such as payment, loyalty and ID schemes, or to enable devices with NFC connectivity.

As a latest generation product, SCL3711 can be supported by SCM's middleware that resides above the PC/SC API and offers better portability of applications and abstraction of smart card related details that need to be handled by applications developed on top of the PC/SC API.

3.2. SCL3711 key features

- Multi-protocol 13.56MHz contactless reader:
 - ISO14443 type A & B
 - MIFARE (Classic, DESFire, UL, UL-C, MIFARE PLUS)
 - FeliCa™
 - NFC Peer-to-peer communication will be available through driver upgrade
- PC/SC v2.0 compliant

3.3. SCL3711 ordering information

Item	Part number	
SCL3711	905108	
Contactless SDK	905124	

3.4. SCL3711 customization options

Upon request, SCM can customize:

- The color of the casing
- The logo
- The product label
- The USB strings

Terms and conditions apply, please contact your local SCM representative or send an email to sales@scmmicro.com.

3.5. Contactless communication principles and SCL3711 usage recommendations

SCL3711 is a contactless reader¹ designed to communicate with user tokens.

User tokens² are made of a contactless integrated circuit card connected to an antenna

User tokens can take several form factors:

- Credit card sized smart card
- Key fob
- NFC mobile phone etc...

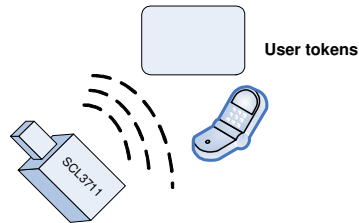

Communication between SCL3711 and user tokens uses magnetic field inductive coupling.

The magnetic field generated by SCL3711 has a carrier frequency of 13.56MHz.

3.5.1. Power supply

When the user token is put in the magnetic field of the reader, its antenna couples with the reader and an induction current appears in the antenna thus providing power to the integrated circuit. The generated current is proportional to the magnetic flux going through the antenna of the user token.

3.5.2. Data exchange

The carrier frequency of the magnetic field is used as a fundamental clock signal for the communication between the reader and the card. It is also used as a fundamental clock input for the integrated circuit microprocessor to function.

To send data to the user token the reader modulates the amplitude of the field. There are several amplitude modulation and data encoding rules defined in ISO/IEC 14443 and ISO/IEC 18092. The reader should refer to those standards for further details.

To answer to the reader, the integrated circuit card of the user token modulates its way of loading (impedance) the field generated by the reader. Here also further details can be found in ISO/IEC 14443 and ISO/IEC 18092.

¹ In the ISO/IEC 14443 standard, the reader is called the proximity coupling device (PCD)

² In the ISO/IEC 14443 standard, the user token is called proximity integrated chip card (PICC)

3.5.3. Recommendations

The communication between the reader and the user token is sensitive to the presence of material or objects interfering with the magnetic field generated by the reader.

The presence of conductive materials like metal in the vicinity of the reader and the user token can severely degrade the communication and even make it impossible. The magnetic field of the reader generates Eddy or Foucault's currents in the conductive materials; the field is literally absorbed by that kind of material.



It is recommended for proper communication to avoid putting SCL3711 in close proximity of conductive materials.

The presence of multiple user tokens in the field also interferes with the communication. When several user tokens are in the field of the reader, load of the field increases which implies that less energy is available for each of them and that the system is detuned. For this reason, SCM Microsystems has implemented in its driver the support for 1 slot only.



It is recommended to present only one user credential at a time in front of SCL3711.

The communication between the reader and the user token is sensitive to the geometry of the system {reader, user token}. Parameters like the geometry and specially the relative size of the reader and user token antennas directly influence the inductive coupling and therefore the communication.

SCL3711 was primarily designed and optimized to function with user credentials of various technologies having the size of a credit card.



It may happen that SCL3711 is not capable of communicating with extremely large or extremely small antennas.



In order to optimize the coupling between the reader and the user token, it is recommended to put both antennas as parallel as possible



In order to optimize transaction speed between the reader and the card it is recommended to place the user token as close as possible to the reader. This will increase the amount of energy supplied to the user credential which will then be able to use its microprocessor at higher speeds

3.6. Applications

3.6.1. General

SCL3711 is a transparent reader designed to interface a personal computer host supporting PC/SC interface with 13.56MHz user tokens like public transport cards, contactless banking cards, NFC forum tags, electronic identification documents – e.g. e-passports, e-ID cards, driving licenses etc.

Those user tokens can have several form factors like credit cards, key fobs, NFC mobile phones or USB dongles like SCT3511 or @MAXX Lite that SCM Microsystems markets.

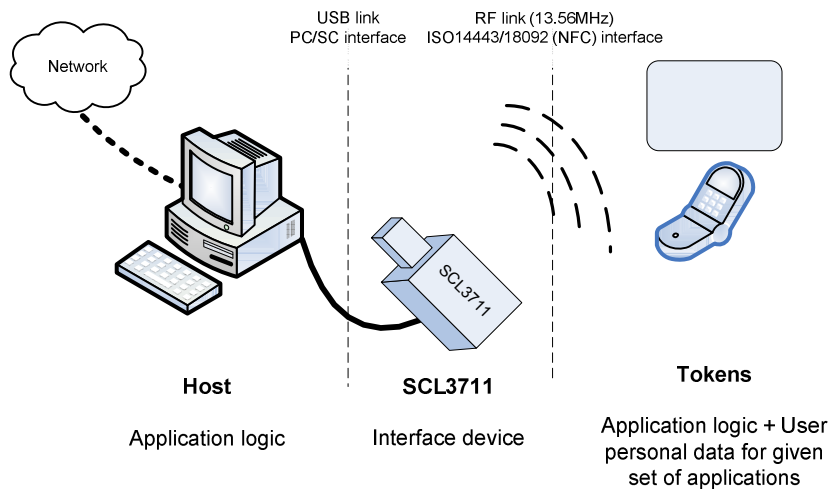

SCL3711 itself handles the communication protocol but not the application related to the token. The application-specific logic has to be implemented by software developers on the host.

3.6.2. Applications provided by SCM Microsystems

SCM Microsystems does not provide payment or transport applications.

SCM Microsystems provides a few applications for development and evaluation purposes that can function with SCL3711. They are available within the software development kit. There are many tools provided but the two main ones are:

- The NFC forum tag reader/writer is a standalone application that enables the user to read and write NFC forum compliant records into NFC forum compatible tags. It is an easy to use tool to configure rapidly NFC forum tag demonstrations.
- Smart card commander version 1.1 provides a module which for NFC forum tags that parses and presents in XML format the content of the tag. Smart card commander also contains powerful scripting functionality which can be very useful for developers to develop and debug their applications.

4. SCL3711 characteristics

4.1. SCL3711 high level architecture

4.1.1. Block diagram

The link between SCL3711 and the host to which it is connected is the USB interface providing both the power and the communication channel.

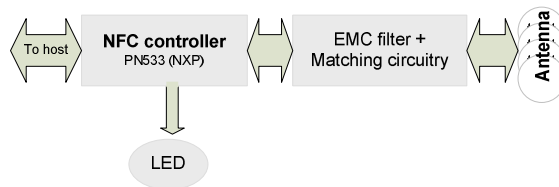

SCL3711 is based designed around an NFC controller which handles the USB communication to the host and the RF communication. This controller ensures the coding/decoding/framing modulation/demodulation required for the RF communication.

The matching circuitry provides the transmission and receiver paths adaptation for the antenna to function properly.

4.1.2. Software architecture

Applications can interface with the driver directly through the PC/SC interface or through the SCM proprietary interface to the NFC wrapper.

The NFC wrapper simplifies the usage of the different NFC Forum tags with the SCL3711 and other SCM contactless readers. It provides a unique API to application developers, which enables them to read and modify NDEF records without further knowledge of the underlying hardware and protocols. Detailed information about the NFC wrapper can be found in SCM's Contactless SDK.

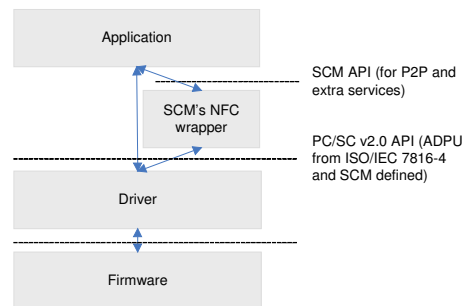

The SCL3711 driver implements PC/SC v2.0 API towards upper layers. The SCL3711 driver for Windows platforms is based on the Windows Driver Framework (WDF) version 1.09.

4.2. Quick reference data

4.2.1. SCL3711 dimensions

Item	Characteristic	Value
SCL3711	Weight	10.2 Grams
	External dimensions(mm)	65.4(L) x 24(W) x 10 (H)
	Cable length	NA
	Default color	BLACK Textured Finish
	Default logo	SCM logo
	Default label	

Drawing with dimensions of the SCL3711 and accessories can be found in annex.

4.2.2. LED behavior

The LED behavior of the SCL3711 is given below.

SCL3711 states	LED Indication (GREEN)
After plug-in (no driver loaded)	OFF
Driver successfully loaded	ON
User token arriving in the field	One blink
User token removed from the field	ON, no specific visual indication
Suspend/hibernate/shutdown state	OFF
SCL3711 disabled	OFF

4.2.3. Other data

Parameter	Value/Description
DC characteristics	Low bus powered (SCL3711 draws power from USB bus) Voltage: 5V Max Current : 100mA Suspend current : 260uA
Clock of the device controller	Max 27.12MHz
RF carrier frequency	13.56 MHz +/- 50 ppm
Modulation	As defined in ISO/IEC 14443
Unloaded field strength	1.5 A/m to 2.2 A/m (Un-modulated RF on reader casing)
USB specification	USB 2.0 FS Devise

USB Speed	Full Speed Device (12Mbit/s)
Device Class	Vendor
PID	0x5591
VID	0x04E6
API	PC/SC 2.0
ID1 format tokens supported	NFC forum tag type 1 through SCM-specific APDU NFC forum tag type 2 through PC/SC-defined APDUs NFC forum tag type 3 through SCM-specific APDU NFC forum tag type 4 through PC/SC APDUs ISO/IEC 14443-4 PICC type A and type B MIFARE (Classic, DESFire, Ultralight, Ultralight C, MIFARE PLUS ³) Non-Secure FeliCa™
Maximum baud rate	848 Kbps
Multiple PICC in field	Not supported
Operating temperature range	-20°C – +70°C
Operating humidity range	Up to 95%RH non condensing
Storage condition range	-40°C – + 85°C
Certifications	USB CE FCC VCCI WEEE RoHS WHQL UL Radio Frequency for Japan

³ MIFARE PLUS cards in security level 2, ISO14443-3 commands are not supported because the SAK byte of those user tokens doesn't indicate it is supported

5. Software modules

SCL3711 is provided with an installer.

5.1. Installation

Make sure the SCL3711 is not plugged in your PC before you start.

Start the installer by double clicking on setup.exe  and then follow the wizard instructions

Click Next on the welcome page of the installer

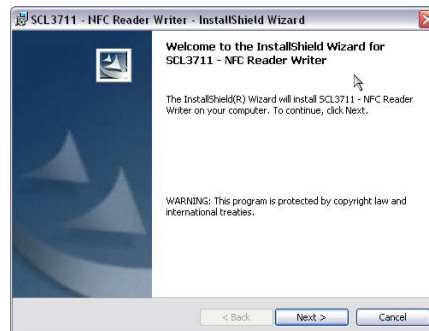

Read the license agreement. You have to accept it in order to be able to install the driver.

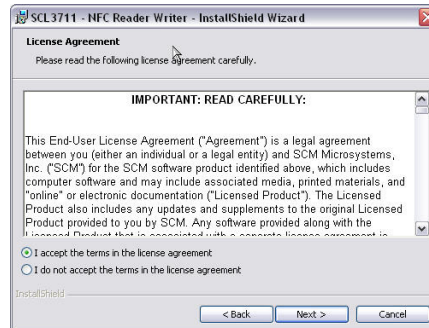

Then install

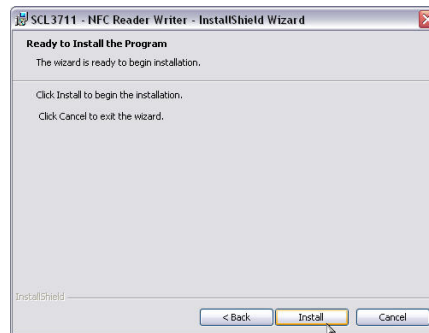

After a few minutes, you are notified the installation happened correctly

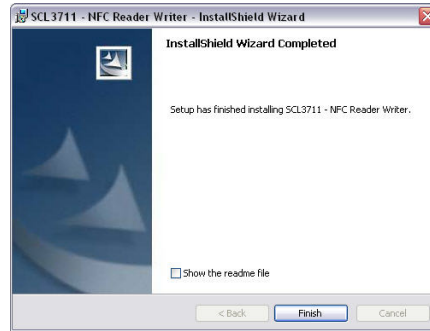

The installer will then prompt you to insert your SCL3711 to update the memory settings.

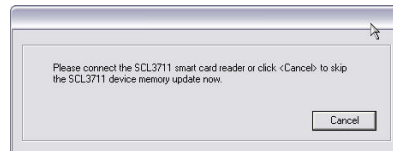

You are ready to use your SCL3711

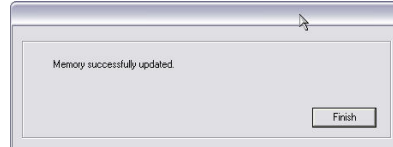

In some very rare cases, you may be asked to reboot your PC. Please do so if this is the case.

5.1.1. Command line parameters for installation

A few parameters of the installer can be configured when launching the installer from the command line

Silent mode of installation	Setup.exe /s /v"/qn"
Installation with no dialogs	Setup.exe /v"LIMITUI=1"
No reboot dialog	Setup.exe /v"REBOOTREQD=0"

5.1.2. Command line parameters for un-installation.

A few parameters of the installer can be configured when launching the installer from the command line

Silent mode of un-installation	<system folder>\Msiexec.exe /x<path to msi file>\<msi file name> /qn
De-installation with no dialogs	<system folder>\Msiexec.exe /x<path to msi file>\<msi file name> LIMITUI=1
No reboot dialog	<system folder>\Msiexec.exe /x<path to msi file>\<msi file name> REBOOTREQD=0

5.2. Utilities

NA

5.3. Driver

The driver for Windows platforms is based on Microsoft WDF architecture 1.09.

The driver package contains INF, SYS, CAT and the co-installer DLL required for the WDF architecture.

5.3.1. SCL3711 listing

SCL3711 enumerates as *SCL3711-NFC&RW*

After the driver is installed, SCL3711 appears in Windows resource manager as *SCL3711 reader & NFC device*:

SCL3711 is listed by PC/SC applications as *SCM Microsystems Inc. SCL3711 reader & NFC device N*. Where N=0 if only one SCL3711 is connected but is incremented in case several SCL3711 are connected to the host.

5.3.2. Supported operating systems

Operating systems supported by the driver:

- Windows 2000 SP4
- Windows 2003 Server (32 & 64 bit)
- Windows XP (32 & 64 bit)
- Windows Vista (32 & 64 bit)
- Windows Server 2008 (32 & 64 bit)
- Linux (32 & 64 bit)
- MACOSX



5.3.3. PC/SC 2.0 compliant ATR

5.3.3.1. Determining the technology of the user credential

The ScardControl method of PC/SC (see [http://msdn.microsoft.com/en-us/library/aa379474\(VS.85\).aspx](http://msdn.microsoft.com/en-us/library/aa379474(VS.85).aspx)) should be used to send the 0x90 IOCTL to SCL3711 in order to determine what type of technology is the user token based on. The output buffer is a BYTE with the following meaning:

Technology	Value
MIFARE1K	0x01
MIFARE4K	0x02
MIFARE Ultralight and Ultralight C	0x03
ISO14443-4A	0x04
FeliCa	0x05
Topaz	0x06
ISO14443-4B	0x07

Once a user credential is selected the driver constructs an ATR from the fixed elements that identify the token. Depending on the user technology this ATR can be analyzed as described hereunder.

5.3.3.2. ATR for type A memory user tokens

The ATR of the user token is composed as described in the table below. In order to allow the application to identify the storage card properly, it's Standard and Card name describing bytes must be interpreted according to the Part 3 Supplemental Document, maintained by PC/SC.

Byte#	Value	Designation	Description
0	0x3B	Initial header	
1	0x8n	T0	n indicates the number of historical bytes in following ATR
2	0x80	TD1	Nibble8 indicates no TA2, TB2, TC2 Nibble 0 means T=0
3	0x01	TD2	Nibble8 indicates no TA3, TB3, TC3 Nibble 1 means T=1
4...3+n	0x80		A status indicator may be present in an optional TLV data object
	0x4F	Optional TLV data object	Tag: Application identifier
	Lentgh		1 byte
	RID		Registered identifier on 5 bytes
	PIX		Proprietary identifier extension on 3 bytes
0x00 0x00 0x00 0x00	4 RFU bytes		
4+n	0x91	TCK	XOR of all previous bytes

Example of the ATR built for a MIFARE Classic 4K card:

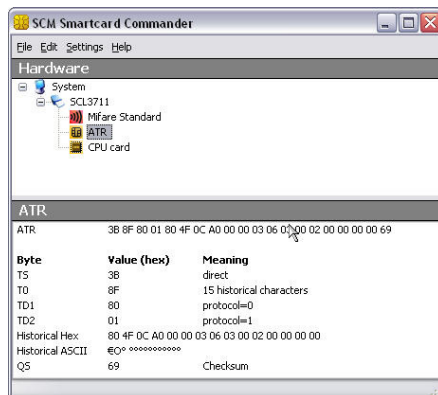

5.3.3.3. ATR for an NFC Forum tag type 1 user token (Topaz)

Byte#	Value	Designation	Description
0	0x3B	Initial header	
1	0x82	T0	TD1 present. 2 historical bytes in following ATR
2	0x80	TD1	Nibble8 indicates no TA2, TB2, TC2 and TD2 present Nibble 0 means T=0
3	0x01	TD2	Nibble8 indicates no TA3, TB3, TC3 Nibble 1 means T=1
4	0x02	Card Mode	NFC TAG operating at Passive 106 baud rate
5	0x44	Card Type	Card type is Topaz
6	0xXX	TCK	XOR of all previous bytes

Example of the ATR built for a Topaz tag:

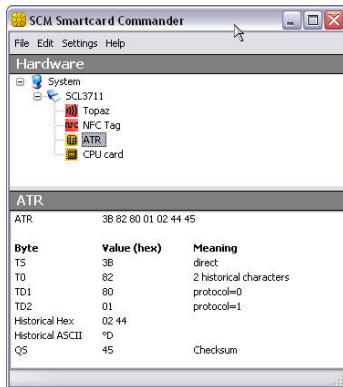

5.3.3.4. ATR for a NFC Forum tag type 3 user token (FeliCa)

Byte#	Value	Designation	Description
0	0x3B	Initial header	
1	0x8C	T0	TD1 present. 12 historical bytes in following ATR
2	0x80	TD1	Nibble8 indicates no TA2, TB2, TC2 and TD2 present Nibble 0 means T=0
3	0x01	TD2	Nibble8 indicates no TA3, TB3, TC3 Nibble 1 means T=1
4	0x04	Card Mode	NFC TAG operating at Passive 212 baud rate
5	0x43	Card Type	Card type is Felica
6	0xFD	IFS	Maximum frame size of felica card
7-14	-	ID	Felica card Identifier – 8 bytes
15	0xXX	Timeout	Write Timeout indicated by card
16	0xXX	TCK	XOR of all previous bytes

Example of the ATR built for a FeliCa user token:

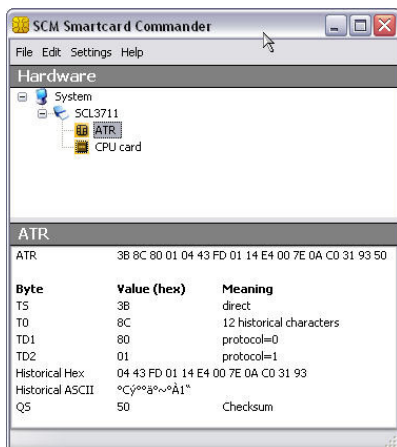

5.3.3.5. ATR for ISO/IEC 14443-4 user tokens

The user token exposes its ATS or application information which is mapped to an ATR. The table describes how this mapping is done.

Byte#	Value	Designation	Description
0	0x3B	Initial header	
1	0x8n	T0	n indicates the number of historical bytes in following ATR
2	0x80	TD1	Nibble8 indicates no TA2, TB2, TC2 Nibble 0 means T=0
3	0x01	TD2	Nibble8 indicates no TA3, TB3, TC3 Nibble 1 means T=1
4...3+n		Historical bytes or application information	Type A: the historical bytes from the ATS (up to 15 bytes) Type B (8 bytes): <ul style="list-style-type: none"> Byte 0 through 3: application data from ATQB, Byte 4 through 6: protocol info byte from ATQB, Byte 7: highest nibble is the MBLI (maximum buffer length index) from ATTRIB, lowest nibble is 0x0
4+n		TCK	XOR of all previous bytes

Example of the ATR built for an ISO14443-4 user tokens:

Type A

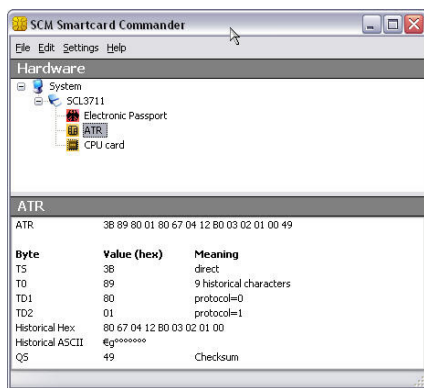

Type B

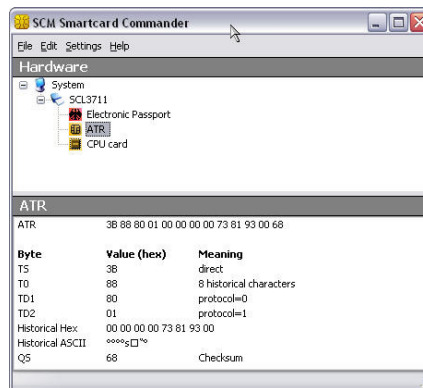

5.4. Firmware

5.4.1. Transport protocol

SCL3711 implements a transport protocol which is proprietary to NXP Semiconductors.

5.4.2. Automatic PPS

Automatic PPS implemented is implemented. SCL3711 will automatically switch the highest baud rate commonly supported by the SCL3711 and the user token

The maximum speed supported by SCL3711 is 848Kbps by default.

6. Commands description

6.1. Generic APDUs

6.1.1. Get UID Command

6.1.1.1. Description

This command will retrieve the UID or SNR or PUPI of the user token. This command can be used for all supported contactless technologies.

6.1.1.2. Format

CLA	INS	P1	P2	Lc	Data in	Le
0xFF	0xCA	0x00	0x00	-	-	XX

Setting Le = 0x00 can be used to request the full UID or PUPI is sent back

- For ISO14443A possible lengths are 4, 7 or 10
- For ISO14443B possible length is 4 bytes PUPI
- For FeliCa™ or NFC Forum type 3 tags possible length is 12 bytes of NFCID
- For NFC Forum type 1 tags possible length is 7 bytes of UID

6.1.1.3. Response

Data Out
Data + SW1 + SW2

6.1.1.4. Status Words

SW1	SW2	Description
0x90	0x00	NO ERROR
0x62	0x82	WARNING: specified Le is greater than data to be retrieved
0x6C	0XX	ERROR: Wrong Length. 0XX is the exact value for Le

Further error codes can be found in annex

6.1.2. Get DATA Command

6.1.2.1. Description

This command can be used to retrieve the ATS of an ISO/IEC14443-4A user token only.

6.1.2.2. Format

CLA	INS	P1	P2	Lc
0xFF	0xCA	0x01	0x00	0x00

6.1.2.3. Response

Data Out
ATS + SW1 + SW2

6.1.2.4. Status Words

SW1	SW2	Description
0x90	0x00	NO ERROR
0x6A	0x81	Command not supported

6.1.3. T=CL user Command

6.1.3.1. Description

This command can be used to send raw data to the user token. SCL3711 will add T=CL protocol data to the raw data you send.

6.1.3.2. Format

CLA	INS	P1	P2	P3	Data
0xFF	0xFE	0x00	0x00	Lraw_data	Raw_data

6.1.3.3. Response

Data Out
PICC response data+ SW1 + SW2

6.1.3.4. Status Words

SW1	SW2	Description

User should refer to the status words defined by the PICC manufacturer for a description of the status words

6.1.3.5. Example

Let's consider the Select command defined in ISO7816-4. This command being ISO can be sent to the user token in 2 different way:

- Using the T=CL command
- Using the T=CL user command

Here are the 2 answers for the select command:

```
ATR length: 14
ATR: 3B 89 80 01 4D 54 43 4F 53 73 01 01 01 3C
APDU: 00 A4 00 00
SW12: 9000 (OK)
```

```
APDU: FF FE 00 00 04 00 A4 00 00
SW12: 9000 (OK)
```

The T=CL command is nevertheless more useful for sending commands which are not defined in ISO7816.

Formatted: Bullets and Numbering

Formatted: Bullets and Numbering

Formatted: Bullets and Numbering

Formatted: Bullets and Numbering

6.1.4. PASS_THROUGH command

6.1.4.1. Description

This command can be used to send raw data to the user token. SCL3711 will not add transport protocol data to the raw data – e.g. PCB, NAD, CID etc.

6.1.4.2. Format

CLA	INS	P1	P2	P3	Data
0xFF	0xEF	0x00	0x00	Lraw_data	Raw_data

6.1.4.3. Response

Output buffer
PICC response data

6.1.4.4. Status Words

NA

6.1.4.5. Example

This command can be used to send commands to a MIFARE Ultralight C

The command for generating an 8-byte random number on MIFARE Ultralight C is 0x1A 0x00:

Sending the APDU 0xFF 0xEF 0x00 0x00 0x02 0x1A 0x00

Will return 0xAF followed by 8 byte random number

Formatted: Bullets and Numbering

Formatted: Bullets and Numbering

Formatted: Bullets and Numbering

Formatted: Bullets and Numbering

6.2. Set of APDU for contactless storage user tokens

Command specific return codes are given under each command. Please refer section 7.1.1 (Status words table) for common return codes.

6.2.1. STORAGE_CARD_CMDS_READ_BINARY

6.2.1.1. Description

Using this APDU, application can read a memory block on user tokens based on technologies like MIFARE Classic 1K or 4K (block size 0x10 bytes) or MIFARE Ultra light (block size 0x04 bytes).

6.2.1.2. Format

CLA	INS	P1	P2	Le
0xFF	0xB0	0x00	Block #	0xFF

Where:

- P2 indicates the block number from where to read
- Le can be a short (maximum value 255) or extended (maximum value 65535). If Le=0x00, then all the bytes until the end of the file are read within the limit of 256 for a short Le field and 65536 for an extended Le field.

6.2.1.3. Response

Data Out
Data + SW1 + SW2

6.2.1.4. Status Words

SW1	SW2	Description
0x90	0x00	NO ERROR
0x69	0x82	Security status not satisfied
0x64	0x00	State of non volatile memory unchanged

6.2.1.5. Example

For a MIFARE Classic 1K card which has the following memory content:

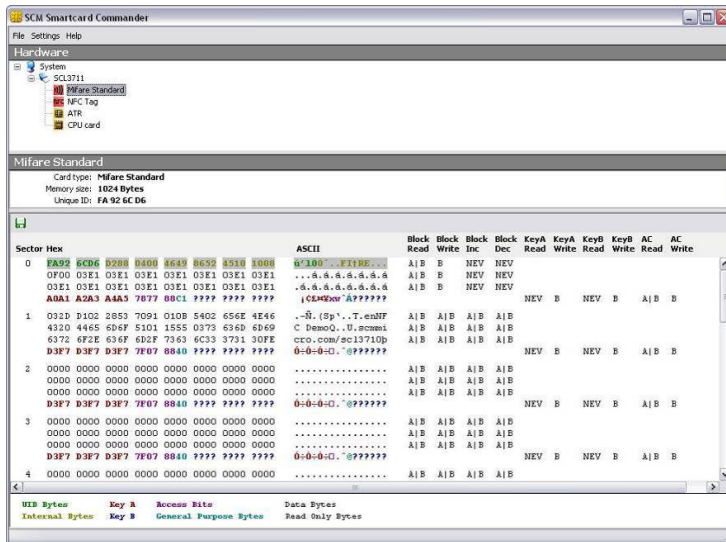

To read the seventh block, you have to issue the following command and get the following response:

```

APDU: FF 80 00 06 10
SW12: 9000 (OK)
DataOut: 63 72 6F 2E 63 6F 6D 2F 73 63 6C 33 37 31 30 FE (16 byte(s))
    
```

6.2.2. STORAGE_CARD_CMDS_WRITE_BINARY

6.2.2.1. Description

This APDU writes data pattern in to a memory address

6.2.2.2. Format

CLA	INS	P1	P2	Lc	Data in
0xFF	0xD6	0x00	Block #	0xFF	Data

Where:

- P2 indicate the memory block number where data should be written
- Lc=0x10 for MIFARE Classic 1K/4K. Lc=0x04 for MIFARE Ultralight

6.2.2.3. Response

Data Out
SW1 + SW2

6.2.2.4. Status Words

SW1	SW2	Description
0x90	0x00	NO ERROR
0x69	0x82	Security status not satisfied
0x64	0x00	State of non volatile memory unchanged

6.2.2.5. Example

For a MIFARE Classic 1K card which has the following memory content:

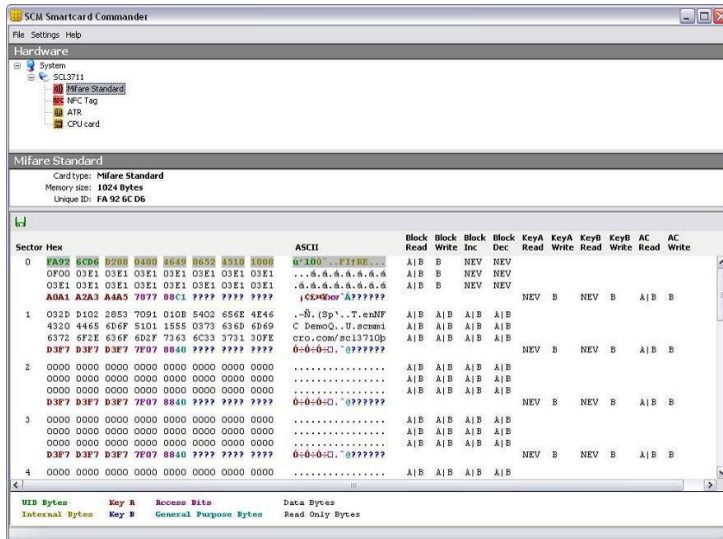

Issuing the command

```
APDU: FF D6 00 09 10 11 11 11 11 11 11 11 11 11 11 11 11 11 11 11 11 11
SW12: 9000 (OK)
```

Will have the following effect on the memory content

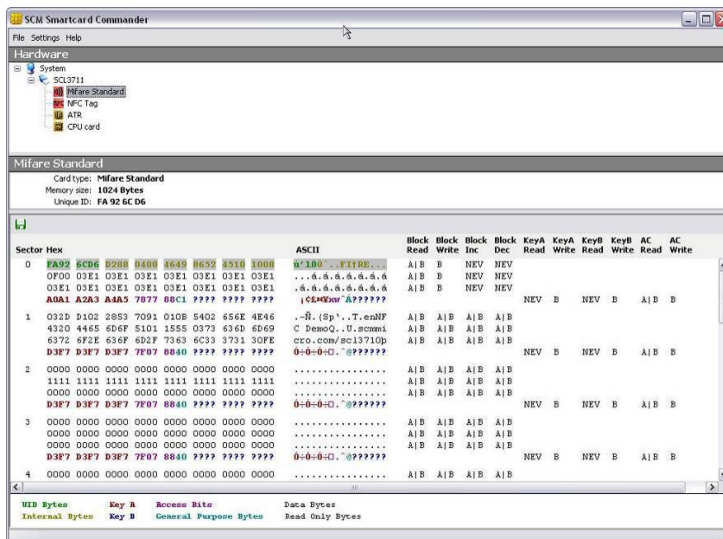

6.2.3. STORAGE_CARD_CMDS_LOAD_KEYS

6.2.3.1. Description

Some type of user tokens like MIFARE Classic may require that the an authentication happens before any data can be read or written. To encrypt perform this authentication, keys need to be loaded in the reader's memory using this command.

6.2.3.2. Format

CLA	INS	P1	P2	Lc	Data in
0xFF	0x82	0x00	Key Type	Key Length	Key value

Where P2 can have the following values (please refer to MIFARE documentation from NXP for further details on what is key A and Key B):

- 0x60 to use the Key A
- 0x61 to use the Key B

6.2.3.3. Response

Data Out
SW1 + SW2

6.2.3.4. Status Words

SW1	SW2	Description
0x90	0x00	NO ERROR
0x69	0x83	Reader key not supported
	0x85	Secured transmission not supported
	0x87	Non volatile memory not available
	0x88	Key number not valid
	0x89	Key length not correct

6.2.4. STORAGE_CARD_CMDS_AUTHENTICATE

6.2.4.1. Description

This command enables to perform authentication for user tokens based on MIFARE Classic 1K or 4K. Before this command can be successfully executed, the STORAGE_CARD_CMDS_LOAD_KEY command must have been executed.

6.2.4.2. Format

CLA	INS	P1	P2	Lc	Data in
0xFF	0x86	0x00	0x00	0x05	Data

Where the data field is structured as follow

Byte #	Value	Description
B0	0x01	Version
B1		Address MSB
B2		Address LSB
B3	0x60	Key A
	0x61	Key B
B4		Number of the key to be used for authentication

Information about memory structure of MIFARE Classic must be requested from NXP Semiconductors.

6.2.4.3. Response

Data Out
SW1 + SW2

6.2.4.4. Status Words

SW1	SW2	Description
0x90	0x00	NO ERROR
0x63	0x00	WARNING no further info
0x69	0x82	Security status not satisfied
	0x84	Referenced key not usable
	0x86	Key type not known

6.2.4.5. Example

For a MIFARE Classic 1K card which has the following memory mapping:

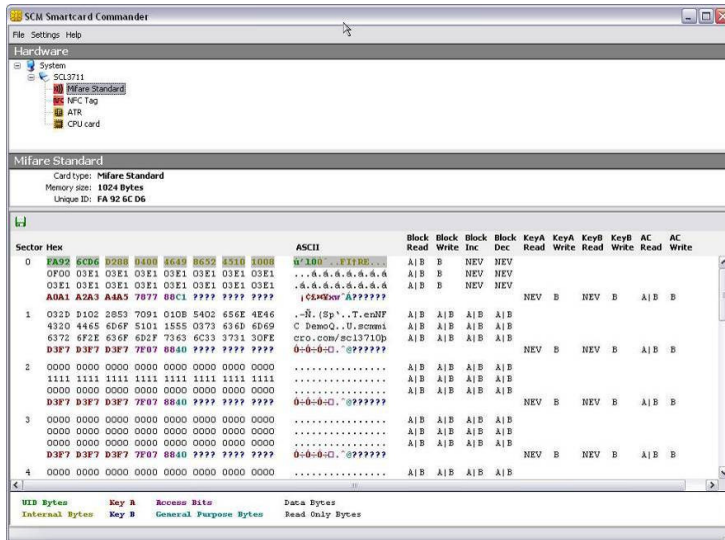

Authenticating with Key A against sector 0 would require sending the following sequence of APDU

```
APDU: FF 82 00 60 06 A0 A1 A2 A3 A4 A5
SW12: 9000 (OK)

APDU: FF 86 00 00 05 01 00 02 60 00
SW12: 9000 (OK)
```

Authenticating with Key A against sector 1 or 2 would require sending the following sequence of APDU

```
ATR: 3B 8F 80 01 80 4F 0C A0 00 00 03 06 03 00 01 00 00 00 00 6A
APDU: FF 82 00 60 06 D3 F7 D3 F7 D3 F7
SW12: 9000 (OK)

APDU: FF 86 00 00 05 01 00 09 60 00
SW12: 9000 (OK)
```

6.2.5. STORAGE_CARD_CMDS_VALUE_BLOCK

6.2.5.1. Description

This APDU is used to interact with MIFARE Classic e-purse applications. Please refer to MIFARE Classic documentation available from NXP Semiconductors for further details on MIFARE classic memory mapping and commands.

6.2.5.2. Format

CLA	INS	P1	P2	Lc	Data in
0xFF	0xF0	0x00	Block #	Lc	Increment/Decrement, Block number, Value

Where P1, P2 code the address of the block number addressed

Where the data field is structured as follow

Byte #	Value	Description
B0	0xC0	Increment
	0xC1	Decrement
B1		Block number
B2-B5		Value (LSB first)

6.2.5.3. Response

Data Out
SW1 + SW2

6.2.5.4. Status Words

SW1	SW2	Description
0x90	0x00	NO ERROR
0x69	0x82	Security status not satisfied

6.2.5.5. Example

CLA	INS	P1	P2	Lc	Data in
0xFF	0xF0	0x00	0x1E	0x06	0xC0 0x1E 0x01 0x00 0x00 0x00

Will increment block number 0x1E of a MIFARE Classic-based user token by a value of 0x01.

6.4. MIFARE DESFire commands

MIFARE DESFire native commands can be mapped onto case 4 APDU as described hereunder:

CLA	INS	P1	P2	P3	Data	Le
0x90	DESFire cmd code	0x00	0x00	Length of data field	DESFire command parameters	0x00

The response from a DESFire user token will be mapped as follow

Data	SW1 SW2
User token answer	0x91 0xYY

0xYY is the DESFire native status byte as described in NXP documentation.

Note: In the past SCM Microsystems had its own proprietary APDU for handling DESFire cards that was implemented on SCL010 and SDI010 products. It is still supported but SCM recommends to use this mapping method for any new development.

6.5. Set of APDU defined by SCM Microsystems

6.5.1. Commands for communicating with NFC Forum Tags Type 1

Commands for Static and Dynamic Memory Models

- Read Identification (RID)
- Read All Blocks 0 – Eh (RALL)
- Read Byte (READ)

Commands for Dynamic Memory Model

- Read Segment (RSEG)
- Read 8 Bytes (READ8)
- Write-No-Erase 8 Bytes (WRITE-NE8)

6.5.1.1. Read Identification (RID)

Description

This command is used to retrieve the tag's unique identifier.

Format

CLA	INS	P1	P2	P3	Data
0xFF	0x50	0x00	0x00	0x00	-

Response

Data	SW1 SW2
HR0 HR1 UID0 UID1 UID2 UID3	0x90 0x00

6.5.1.2. Read All Blocks (RALL)

Description

The RALL command reads-out the two header ROM bytes and the whole of the static memory blocks 0x0-0xE.

Format

CLA	INS	P1	P2	P3	Data
0xFF	0x52	0x00	0x00	0x00	-

Response

Data	SW1 SW2
HR0 HR1 120 bytes (Blocks 0x0 – 0xE)	0x90 0x00

Example

For a Topaz-based user token that has the following memory content

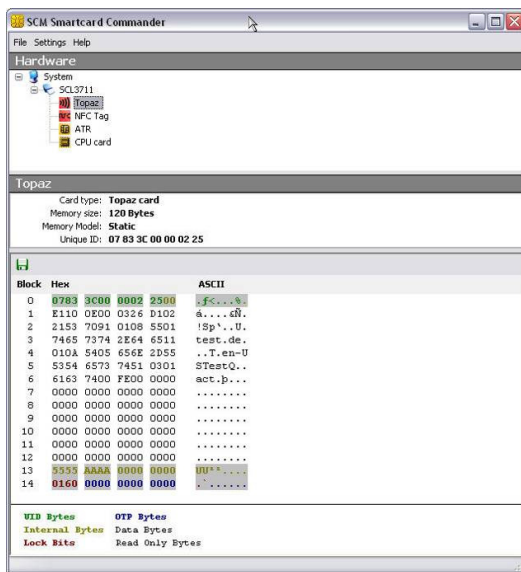

The following APDU sequence can be used to retrieve the identifier and read all the blocks

```

ATR length: 7
ATR: 3B 82 80 01 02 44 45
APDU: FF 50 00 00 00
SW12: 9000 (OK)
DataOut: 11 48 07 83 3C 00 (6 byte(s))

APDU: FF 52 00 00 00
SW12: 9000 (OK)
DataOut: 11 48 07 83 3C 00 00 02 25 0E 11 0E 00 03 26 D1 02 21 53 70 91 01 08 55 01 74 65 73 74 2E 64 65 11 01 0A 54 05 65 6E 2D 55 53 54 65 73 74 51 03 01 61 63 74 00 FE 00 00 00 00
    
```

6.5.1.3. Read Byte (READ)

Description

This command reads a single EEPROM memory byte within the static memory model area of blocks 0x0-0xE.

Format

CLA	INS	P1	P2	P3	Data
0xFF	0x54	0x00	Byte Address	0x00	-

Where P2 is coded as follow

Bit #	Value	Description
b0 – b2		Byte number to be addressed(value between 0x0 and 0x7)
b3 – b6		Block number (value between 0x0 and 0xE)
b7	(0)b	Number of the key to be used for authentication

Response

Data	SW1 SW2
1 byte of data	0x90 0x00

6.5.1.4. Write-Erase Byte (WRITE-E)

Description

This commands erases and then writes the value of an individual memory byte within the static memory model area of blocks 0x0-0xE.

Format

CLA	INS	P1	P2	P3	Data
0xFF	0x56	0x00	Byte Address	0x01	1 byte of data to be written

Where P2 is coded as follow

Bit #	Value	Description
b0 – b2		Byte number to be addressed(value between 0x0 and 0x7)
b3 – b6		Block number (value between 0x0 and 0xE)
b7	(0)b	Number of the key to be used for authentication

Response

Data	SW1 SW2
Byte value that has been written	0x90 0x00

6.5.1.5. Write-No-Erase Byte (WRITE-NE)

Description

This command writes a byte value on an individual memory byte within the static memory model area of blocks 0x0-0xE.

This command does not erase the value of the targeted byte before writing the new data. Execution time of this command by NFC Forum tags type 1, is approximately half that of the normal write command (WRITE-E). Using this command, EEPROM bits can be set but not reset.

Format

CLA	INS	P1	P2	P3	Data
0xFF	0x58	0x00	Byte Address	0x01	1 byte of data to be written

Where P2 is coded as follow

Bit #	Value	Description
b0 – b2		Byte number to be addressed(value between 0x0 and 0x7)
b3 – b6		Block number (value between 0x0 and 0xE)
b7	(0)b	Number of the key to be used for authentication

Response

Data	SW1 SW2
Value of the memory byte after execution	0x90 0x00

Example

Sending the following command to an NFC Forum type 1 tag that has the value 0x39 in the first EEPROM byte of block 0x1 of its static memory model area

CLA	INS	P1	P2	P3	Data
0xFF	0x58	0x00	0x10	0x01	0xA8

Will give the answer

Data	SW1 SW2
0xB9	0x90 0x00

0x39=(00111001)b

0xA8=(10101000)b

0xB9=(10111001)b

6.5.1.6. Read Segment (RSEG)

Description

This command reads out a complete segment of memory.

Format

CLA	INS	P1	P2	P3	Data
0xFF	0x5A	0x00	Segment Address	0x00	-

Where P2 is coded as follow

Bit #	Value	Description
b0 – b3	(0000)b	RFU
b4 – b7		Segment address (value between 0x0 and 0xF)

Response

Data	SW1 SW2
128 bytes of data	0x90 0x00

6.5.1.7. Read 8 bytes (READ8)

Description

This command reads out a block of memory.

Format

CLA	INS	P1	P2	P3	Data
0xFF	0x5C	0x00	Block Address	0x00	-

P2 – Block Address - b8 - b1 - General block (0x00 -0xFF)

Response

Data	SW1 SW2
8 bytes of data	0x90 0x00

6.5.1.8. Write-Erase 8 bytes (WRITE-E8)

Description

This command erases a memory block and then writes a value to it.

Format

CLA	INS	P1	P2	P3	Data
0xFF	0x5E	0x00	Block Address	0x08	8 bytes of data to be written

Where P2 codes the block address (value between 0x00 and 0xFF)

Response

Data	SW1 SW2
8 bytes of data that have been written	0x90 0x00

6.5.1.9. Write-No-Erase 8 bytes (WRITE-NE8)

Description

This command writes with no erase to a block of memory.

This command does not erase the value of the targeted block before writing the new data. Using this command, EEPROM bits can be set but not reset.

Format

CLA	INS	P1	P2	P3	Data
0xFF	0x60	0x00	Block Address	0x08	8 bytes of data to be written

Where P2 codes the block address (value between 0x00 and 0xFF).

Response

Data	SW1 SW2
8 bytes of data	0x90 0x00

Example

Sending the following command to an NFC Forum type 1 tag that has the value (0x01 0x02 0x03 0x04 0x00 0x00 0x00 0x00) in the first EEPROM block

CLA	INS	P1	P2	P3	Data
0xFF	0x60	0x00	0x00	0x08	0x00 0x01 0x03 0x04 0x05 0x06 0x07 0x08

Will give the answer

Data	SW1 SW2
0x01 0x03 0x03 0x04 0x05 0x06 0x07 0x08	0x90 0x00

6.5.2. Commands for communicating with NFC Forum Tags Type 2

To interact with an NFC Forum tag type 2 the commands STORAGE_CMDS_READ_BINARY and STORAGE_CMDS_WRITE_BINARY previously described in this manual should be used.

Please refer to *NFC Forum tag type 2* specification for definition of the read and write procedures.

6.5.3. Commands for communication with NFC Forum Tags Type 3

This section describes APDUs SCM Microsystems defined for the following FeliCa™ non-secure commands. For further details on FeliCa™ the reader should contact Sony corporation. Some description can also be found in the JIS X 6319-4 (Japanese Industry Standard) or the ISO18092 standards

- REQC
- Request Service
- Request Response
- Read
- Write

For further details on processing NFC Forum tag type 3, please refer to NFC Forum tag type 3 specification.

6.5.3.1. REQC

Description

This command is used to detect the presence of a Type C (i.e NFC Forum Type 3/FeliCa) card in the RF field.

Format

CLA	INS	P1	P2	P3	Data
0xFF	0x40	0x00	0x00	0x04	2 bytes of Service Code, 1 byte RFU, 1 byte TSN

Response

Data	SW1 SW2
16 bytes of NFCID2 + 2 bytes of System Code (sent only if the RFU byte is 0x01)	0x90 0x00

6.5.3.2. Request Service

Description

This command is used to know the area key version of the specified area and the service key version of the specified service of FeliCa card

Format

CLA	INS	P1	P2	P3	Data
0xFF	0x42	Number of services/areas	0x00	2 * P1	Service Code List / Area Code List

Response

Data	SW1 SW2
8 bytes IDm + No. of Service or areas(n) + Service version or area version list (2*n)	0x90 0x00

6.5.3.3. Request response

Description

This command is used to know the current mode (Mode 0/1/2) of the Felica card

Format

CLA	INS	P1	P2	P3	Data
0xFF	0x44	0x00	0x00	0x00	-

Response

Data	SW1 SW2
8 bytes IDm + Mode	0x90 0x00

6.5.3.4. Read

Description

This command is used to read the record value of the specified service of the Felica card

Format

CLA	INS	P1	P2	P3	Data
0xFF	0x46	Number of services	Number of blocks	2*(P1 + P2)	Service Code List, Block List

Response

Data	SW1 SW2
8 bytes IDm + Status Flag 1 + Status Flag 2 + No. of blocks(n) + Block data (n*16)	0x90 0x00

6.5.3.5. Write

Description

This command is used to write the records of the specified service to the Felica card

Format

CLA	INS	P1	P2	P3	Data
0xFF	0x48	Number of services	Number of blocks	$2 * (P1 + P2) + (16 * P2)$	Service Code List, Block List, Block Data

Response

Data	SW1 SW2
8 bytes IDm + Status Flag 1 + Status Flag 2	0x90 0x00

6.5.3.6. Request System Code

Description

This command searches for the system code registered in the card and returns its value. When the card is logically segmented, multiple system codes are returned in the form of a list.

Format

CLA	INS	P1	P2	P3	Data
0xFF	0x4A	0x00	0x00	0x00	-

Response

Data	SW1 SW2
8 bytes IDm + No. of System Codes (n) + System Code List (2n)	0x90 0x00

6.5.4. Commands for communicating with NFC Forum Tags Type 4

To interact with NFC Forum tag type 4 tags, ISO/IEC 7816-4-defined APDU are used and sent through SCL3711 using the T=CL command described earlier in this manual.

The reader can find in *NFC Forum tag type 4* specification both the definition of the APDU commands to be used and the processing methods.

6.6. Escape IOCTL's supported in SCL3711

The reader behavior can be configured with the help of below given IOCTL's. The ScardControl method of PC/SC (see [http://msdn.microsoft.com/en-us/library/aa379474\(VS.85\).aspx](http://msdn.microsoft.com/en-us/library/aa379474(VS.85).aspx)) should be used to send those IOCTLs. Code the API as given below.

```
#define IOCTL_CCID_ESCAPE SCARD_CTL_CODE(3500)

SCardControl (
    __in SCARDHANDLE hCard, // Handle obtained through ScardConnect
    __in DWORD dwControlCode, // Should be set to IOCTL_CCID_ESCAPE
    __in LPCVOID lpInBuffer, // First BYTE contains IOCTL code followed by
    arguments if any
    __in DWORD nInBufferSize, // Total input buffer length
    __out LPVOID lpOutBuffer, // Response buffer
    __in DWORD nOutBufferSize, // Response buffer size
    __out LPDWORD lpBytesReturned // Total number of BYTES returned from the
    driver.
)
```

6.6.1. READER_CNTLESS_GET_ATS_ATQB

6.6.1.1. Description

This escape command can be used to retrieve the ATS bytes of the type A or the ATQB bytes of the type B card present in front of the SCL3711.

6.6.1.2. Input buffer

Byte #	Value	Description
B0	0x93	Escape command code

6.6.1.3. Output buffer

The output buffer is

Byte #	Output buffer
...	ATS or ATQB

6.6.2. READER_GET_CARD_TYPE_POLLING

6.6.2.1. Description

Using this escape command one can retrieve the type of the technology which the reader is configured to poll for.

6.6.2.2. Input buffer

Byte #	Value	Description
B0	0x94	Escape command code

6.6.2.3. Output buffer

Byte #	Output buffer
B0	Configuration register

The output buffer contains 1 byte which is coded as follow:

b7	b6	b5	b4	b3	b2	b1	b0
RFU	RFU	RFU	Felica 424	Felica 212	Topaz	Type B	Type A

Bit value 1 means SCL3711 will poll for that technology; bit value 0 means SCL3711 will not poll for this value.

A reader configured to poll only for type A and type B will therefore answer 0x03 – i.e. (0000011)b to this command.

6.6.3. READER_CNTLESS_SET_TYPE

6.6.3.1. Description

This escape command can be used to configure the polling loop of SCL3711. Applications may use this to optimize the detection speed performance of their system.

6.6.3.2. Input buffer

Byte #	Value	Description
B0	0x95	Escape command code
B1	Configuration register	

The configuration register is 1 byte which is coded as follow:

b7	b6	b5	b4	b3	b2	b1	b0
RFU	RFU	RFU	Felica 424	Felica 212	Topaz	Type B	Type A

Bit value 1 means SCL3711 will poll for that technology; bit value 0 means SCL3711 will not poll for this value. To poll only for FeliCa 424 and type A, B1=0x11.

6.6.3.3. Output buffer

Output buffer
NULL

6.6.4. READER_CNTLESS_RF_SWITCH

6.6.4.1. Description

This escape message ID can be used to retrieve the current RF state (ON/OFF) of SCL3711 as well as to switch the RF state (ON/OFF).

6.6.4.2. Input buffer

Byte #	Value	Description
B0	0x96	Escape command code
B1	Configuration parameter	

Configuration parameter byte can take the following values

Value	Description
0x00	Switch the RF OFF
0x01	Switch the RF ON
0xFF	Get the current RF field state

6.6.4.3. Output buffer

Byte #	Configuration parameter value from input buffer	Output buffer
NA	0x00 or 0x01	NULL
B0	0xFF	0x00 if the field is OFF 0x01 if the field is ON

6.6.5. READER_CNTLESS_DISABLE_PPS

6.6.5.1. Description

Using this escape command one can enable/disable the default automatic PPS behavior of SCL3711. When automatic PPS is disabled communication happens at the lowest baudrate commonly supported by SCL3711 and the user token.

6.6.5.2. Input buffer

Byte #	Value	Description
B0	0x99	Escape command code
B1	Enable automatic PPS	0x00
	Disable automatic PPS	0x01

6.6.5.3. Output buffer

Output buffer
NULL

6.6.6. READER_ENABLE_DISABLE_848

6.6.6.1. Description

This escape message can be used to enable/disable 848kbps support and to get the current state of the 848kbps support. Applications may call this function, to enable/disable 848kbps support.

6.6.6.2. Input buffer

Byte #	Value	Description
B0	0x9D	Escape command code
B1	0x00	Disable 848kbps
	0x01	Enable 848kbps
	0xFF	Get current state

6.6.6.3. Output buffer

Byte #	Configuration parameter value from input buffer	Output buffer
NA	0x00 or 0x01	NULL
B0	0xFF	0x00 if 848kbps disabled
		0x01 if 848kbps enabled

6.6.7. READER_CNTLESS_BAUDRATE

6.6.7.1. Description

This escape message can be used to get the actual communication baud rate between SCL3711 and the user token.

6.6.7.2. Input buffer

Byte #	Value	Description
B0	0x9E	Escape command code

6.6.7.3. Output buffer

Byte #	Value	Comment										
B0	0xXY	<p>Nibble X corresponds to the baudrate from user token to SCL3711</p> <p>Nibble Y corresponds to the baudrate from SCL3711 to user token</p> <table border="1" data-bbox="743 1633 1084 1831"> <thead> <tr> <th>Baudrate</th> <th>Nibble value</th> </tr> </thead> <tbody> <tr> <td>106kbps</td> <td>0x0</td> </tr> <tr> <td>212kbps</td> <td>0x1</td> </tr> <tr> <td>424kbps</td> <td>0x2</td> </tr> <tr> <td>848kbps</td> <td>0x3</td> </tr> </tbody> </table>	Baudrate	Nibble value	106kbps	0x0	212kbps	0x1	424kbps	0x2	848kbps	0x3
Baudrate	Nibble value											
106kbps	0x0											
212kbps	0x1											
424kbps	0x2											
848kbps	0x3											

6.6.8. READER_FORCE_BAUDRATE

6.6.8.1. Description

This escape command is used to force baud rate between the SCL3711 and the user token.

Once sent, the card needs to be disconnected and reconnected before the specific setting is adopted.

6.6.8.2. Input buffer

Byte #	Value	Description								
B0	0xAD	Escape command code								
B1	0x00	Apply baudrate specified by the card								
	0x01	Force baudrate								
B2	0xAB	Byte present only if B1=0x01 Nibble A is the baudrate between SCL3711 and user token Nibble B is the baudrate between user token and SCL3711 Nibbles are coded as follow <table border="1" data-bbox="701 888 954 970" style="margin-left: auto; margin-right: auto;"> <thead> <tr> <th>b3</th> <th>b2</th> <th>b1</th> <th>b0</th> </tr> </thead> <tbody> <tr> <td>0</td> <td>848</td> <td>424</td> <td>212</td> </tr> </tbody> </table>	b3	b2	b1	b0	0	848	424	212
b3	b2	b1	b0							
0	848	424	212							

6.6.8.3. Output buffer

Byte #	Value
NA	NULL

6.6.9. READER_DISABLE_NAK_POLLING

6.6.9.1. Description

This escape command can be used to enable/disable NAK Polling by SCL3711 once a user token has been selected.

6.6.9.2. Input buffer

Byte #	Value	Description
B0	0xAC	Escape command code
B1	0x00	Enable NAK Polling
	0x01	Disable NAK Polling
	0xFF	Gets Current state of NAK polling.

6.6.9.3. Output buffer

Byte #	Configuration parameter value from input buffer	Output buffer
NA	0x00 or 0x01	NULL
B0	0xFF	0x00 NAK polling enabled
		0x01 NAK polling disabled

6.6.10. FELICA_PASSTHROUGH

6.6.10.1. Description

This escape command can be used to send FeliCa commands as defined in JIS X 6319-4 specification. SCL3711 will add the transport level protocol data required.

6.6.10.2. Input buffer

Byte #	Value	Description
B0	0xF3	Escape command code
B1	Cmd code	FeliCa command code
B2...B _{N+2}	N bytes	Data – depends on the cmd code

6.6.10.3. Output buffer

Byte #	Output buffer

Depends on the command code

7. Annexes

7.1. Annex A

7.1.1. Status words table

SW1	SW2	Description
0x90	0x00	NO ERROR
0x67	0x00	LENGTH INCORRECT
0x6D	0x00	INVALID INSTRUCTION BYTE
0x6E	0x00	CLASS NOT SUPPORTED
0x6F	0x00	UNKNOWN COMMAND
0x63	0x00	AUTHENTICATION ERROR
0x65	0x81	STATUS_COMMAND_FAILED
0x65	0x91	STATUS_SECURITY_STATUS_NOT_MET
0x68	0x00	CLASS BYTE INCORRECT
0x6A	0x81	FUNCTION NOT SUPPORTED
0x6B	0x00	WRONG PARAMETER P1-P2

7.1.2. Further information about PC/SC

The PC/SC specifications can be downloaded from the PC/SC workgroup web site: www.pcscworkgroup.com.

Further information on the Microsoft resource manager API can be found online on [http://msdn.microsoft.com/en-us/library/aa380149\(VS.85\).aspx](http://msdn.microsoft.com/en-us/library/aa380149(VS.85).aspx).

7.2. Annex B – Mechanical drawings

