

Modular Servo System

(MSS)

MATLAB 7 (R14 SP2/SP3)
MATLAB R2006a/b, R2007a, R2008a/b, R2009a
PCI version

User's Manual



www.inteco.com.pl

COPYRIGHT NOTICE

© Inteco Sp. z o.o.

All rights reserved. No part of this publication may be reproduced, stored in a retrieval system, or transmitted, in any form or by any means, electronic, mechanical, photocopying, recording or otherwise, without the prior permission of Inteco Sp. z o.o.

ACKNOWLEDGEMENTS

Inteco acknowledges all trademarks.

MICROSOFT, WINDOWS are registered trademarks of Microsoft Corporation.

MATLAB, Simulink, RTWT and RTW are registered trademarks of Mathworks Inc.

Contents

1. INTRODUCTION AND GENERAL DESCRIPTION	5
1.1. Product overview	5
1.2. Equipment and requirements	6
1.3. Hardware installation.....	7
1.4. Software installation	7
2. STARTING, TESTING AND STOPPING PROCEDURES	8
2.1. Starting procedure.....	8
2.2. Testing and troubleshooting.....	8
3. SERVO CONTROL WINDOW.....	13
3.1. Basic test.....	13
3.2. Manual setup.....	13
3.3. RTWT Driver	17
3.4. Simulation Models.....	18
3.5. Identification.....	20
3.6. Demo Controllers.....	20
4. MATHEMATICAL MODEL OF THE SERVO SYSTEM.....	22
4.1. Linear Model	22
4.2. Nonlinear model	24
5. RTWT MODEL.....	26
5.1. Creating a model.....	26
5.2. Code generation and the build process	28
6. BASIC ASSIGNMENTS.....	31
6.1. Basic measurements.....	31
6.2. Steady state characteristics of the DC servo	33
6.3. Identification in time domain.....	35
6.3.1. <i>Identification task by the surface method</i>	35
6.3.2. <i>Time domain identification experiment</i>	36
7. ADVANCED ASSIGNMENTS	38
7.1. PID position control.....	38
7.2. PID Velocity control.....	48
7.3. Multivariable control design	51
7.3.1. <i>Pole-placement method</i>	51
7.3.2. <i>Deadbeat controller</i>	54
7.4. Optimal design method: LQ controller	58
7.4.1. <i>The continuous case</i>	59
7.4.2. <i>The discrete case</i>	63
8. DESCRIPTION OF THE MODULAR SERVO CLASS PROPERTIES.....	66
8.1. BaseAddress	67
8.2. BitstreamVersion	67
8.3. Encoder.....	67
8.4. Angle	68
8.5. AngleScaleCoeff.....	68
8.6. PWM.....	68
8.7. PWMPrescaler	69
8.8. Stop.....	69
8.9. ResetEncoder	69
8.10. Voltage.....	70
8.11. Therm	70
8.12. ThermFlag	70
8.13. Time.....	71
8.14. Quick reference table.....	71

8.15. CServo Example	71
9. SOME TECHNICAL DATA	75

Modular Servo System

1. Introduction and general description

The **Modular Servo System (MSS)** consists of the Inteco digital servomechanism and open-architecture software environment for real-time control experiments. The main concept of the MSS is to create a rapid and direct path from the control system design to hardware implementation. The MSS supports the real-time design and implementation of advanced control methods using MATLAB[®] and Simulink[®] tools and extends the MATLAB environment in the solution of digital servomechanism control problems.

The integrated software supports all phases of a control system development:

- on-line process identification,
- control system modelling, design and simulation,
- real-time implementation of control algorithms.

The Modular Servo System uses standard PC hardware platforms and Microsoft Windows operating systems. Besides the hardware and the related software you obtain the *User's Manual*. The manual:

- shows step-by-step how to design and generate your own real-time controller in MATLAB/Simulink environment,
- contains the library of ready to use real-time controllers and
- includes the set of preprogrammed experiments.

1.1. Product overview

The MSS **setup** (Fig. 1.1) consists of several modules mounted at the metal rail and coupled with small clutches. The modules are arranged in the chain. The DC motor together with tachogenerator opens the chain. The gearbox with the output disk closes the chain. The potentiometer module is located outside the chain.

For example the DC motor can drive activates the following modules: inertia, backlash, encoder module, magnetic brake and the gearbox with the output disk. The rotation angle of the DC motor shaft is measured using an incremental encoder. Anywhere the rotational angle measurement is required we can place the encoder. A tachogenerator is connected directly to the DC motor and generates a voltage signal proportional to the angular velocity.

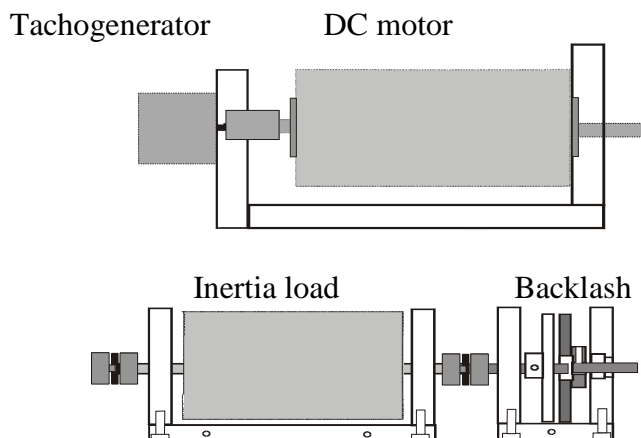

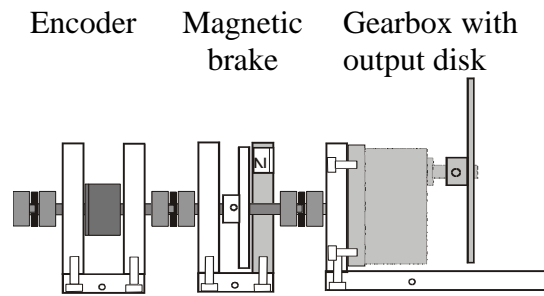

Fig. 1.1 The MSS setup

The servomechanism is connected to a computer where a control algorithm is realized based on measurements of angle and angular velocity. The system has no inner feedback for dead zone compensation. The accuracy of measurement of velocity is 5% while the accuracy of angle measurement is 0.1%. The armature voltage of the DC motor is controlled by PWM signal. For this reason the dimensionless control signal is the scaled input voltage, $u(t) = v(t)/v_{\max}$. The admissible controls satisfy $|u(t)| \leq 1$ and $v_{\max} = 12$ [V].

The measurement system is based on RTDAC/PCI acquisition board equipped with A/D converters.

The I/O board communicates with the power interface unit. The whole logic necessary to activate and read the encoder signals and to generate the appropriate sequence of PWM pulses to control the DC motor is configured in the Xilinx[®] chip of the RT-DAC/PCI board. All functions of the board are accessed from the Modular Servo Toolbox which operates directly in the MATLAB[®]/Simulink[®] environment.

Features

- The set-up is fully integrated with MATLAB[®]/Simulink[®] and operates in real-time in MS Windows[®] 2000/XP.
- Real-time control algorithms can be rapidly prototyped. No C code programming is required.
- The software includes complete dynamic models.
- The *User's Manual* contains a number of pre-programmed experiments familiarising the user with the system in a fast way.

1.2. Equipment and requirements

The following minimum configuration is required:

Hardware:

- MSS including the following modules: Input Potentiometer, DC Motor with Tachogenerator, Gearbox with output disk, Magnetic Brake, Inertia Load, Digital Encoder, Backlash module.
- Computer system based on INTEL or AMD processor.
- Specialised RT-DAC/PCI-D I/O board.
- Power Interface unit.

Software:

- MS Windows® 2000/XP, MATLAB® 7 (R14 SP2/SP3), R2006a/b, R2007a, R2008a/b or R2009a appropriate Simulink®, Real Time Workshop and Real Time Windows Target toolboxes, MSS Control/Simulation Toolbox.



The Modular Servo Toolbox supports Matlab 7 (R14 SP2, SP3), MATLAB R2006a/b, R2007a and R2008a/b and R2009a.

Manuals:

- *Installation Manual*
- *User's Manual*



The experiments and corresponding to them measurements have been conducted by the use of the standard INTECO system. Every new system manufactured and developed by INTECO can be slightly different to the standard. It explains why a user can obtain results that are not identical to these given in the manual.

1.3. Hardware installation

Hardware installation is described in the *Installation Manual*.

1.4. Software installation

Insert the installation CD and proceed step by step following displayed commands. Software installation is described in the *Installation Manual*.

2. Starting, testing and stopping procedures

2.1. Starting procedure

Invoke MATLAB by double clicking on the MATLAB icon. The MATLAB command window opens. Then simply type:

Servo

Servo Control Window opens (see Fig. 2.1). The pushbuttons indicate actions that execute callback routines when the user selects a menu item.

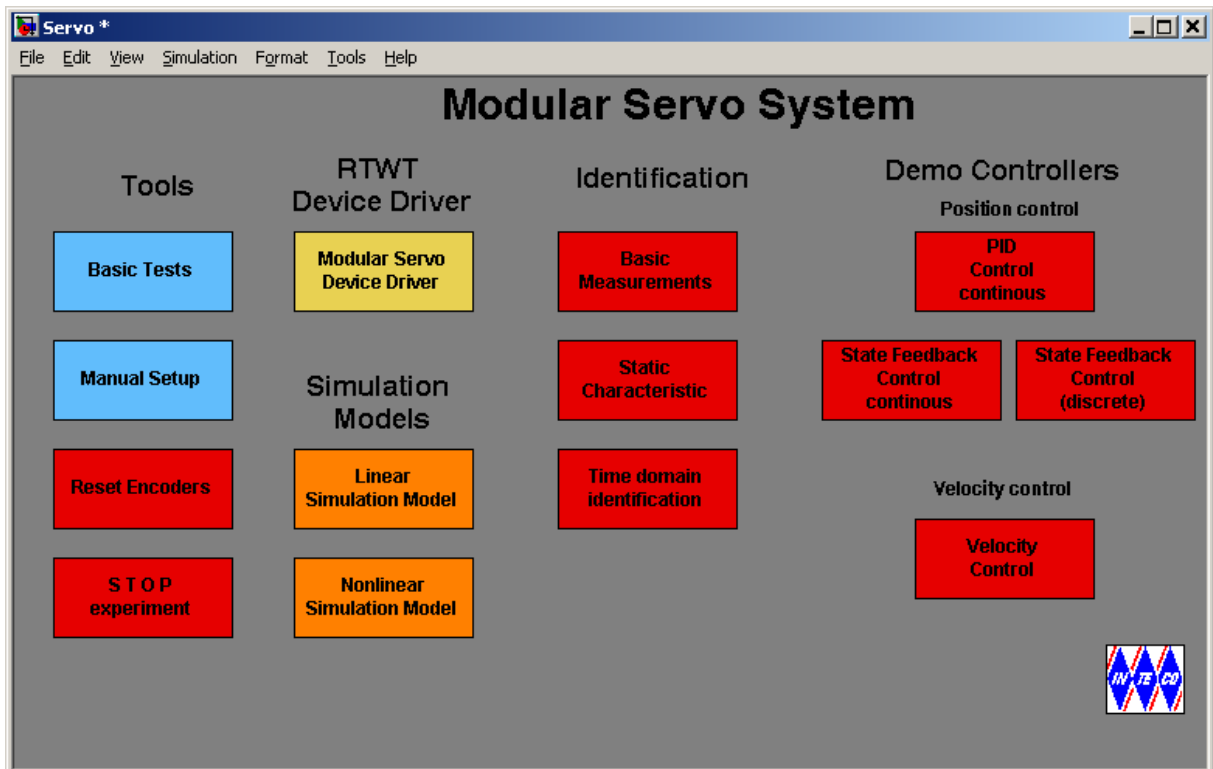

Fig. 2.1 The *Servo Control Window*

The *Servo Control Window* contains: testing tools, drivers, models and demo applications. See section 3 for a detailed description.

2.2. Testing and troubleshooting

This section explains how to perform the tests. These tests allow checking if mechanical assembling and wiring has been done correctly. The tests have to be performed obligatorily after assembling the system. They are also necessary if an incorrect operation of the system takes place. The tests are helpful to look for reasons of errors when the system fails. The tests have been designed to validate the existence and sequence of measurements and controls. They do not relate to accuracy of the signals.

First, you have to be aware that all signals are transferred in a proper way. Five testing steps are applied.

- Double click the *Basic Tests* button. The following window appears (Fig. 2.2):

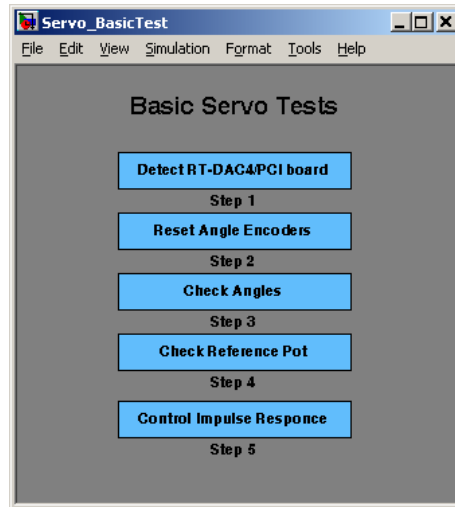

Fig. 2.2 The *Basic Tests* window

The first step in testing of the MSS is to check if the RT-DAC/PCI I/O board is installed properly.

- Double click the *Detect RTDAC/PCI board* button. One of the messages shown in Fig. 2.3 opens. If the board has been correctly installed, the base address, and number of logic version of the board are displayed.



Fig. 2.3 Result of the step 1

If the board is not detected check if the board is put into the slot properly. The boards are tested very precisely before sending to a customer and only wrong assembly procedure invokes errors.

In the next step one can reset encoders. One sets the initial position of the servo system.

- Double click the *Reset Angle Encoders* button. When the window (Fig. 2.4) opens click the *Yes* option. The encoders are reset and zero position of the servo system are stored.

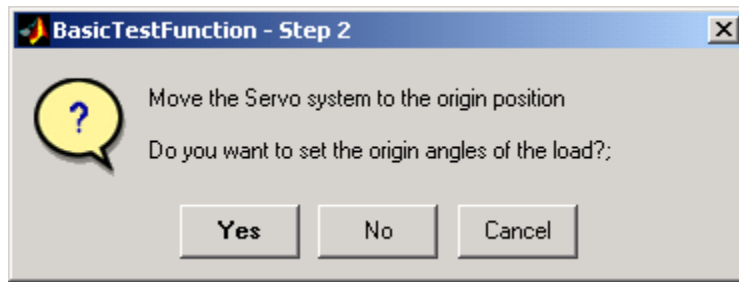

Fig. 2.4 The *Reset Encoders* window

The next step of the testing procedure refers to the angle measurement.

- Double click the *Check Angles* button, next click the *Yes* button and rotate the inertia load by hand. The rotational angle of the inertia is measured and displayed (Fig. 2.5).

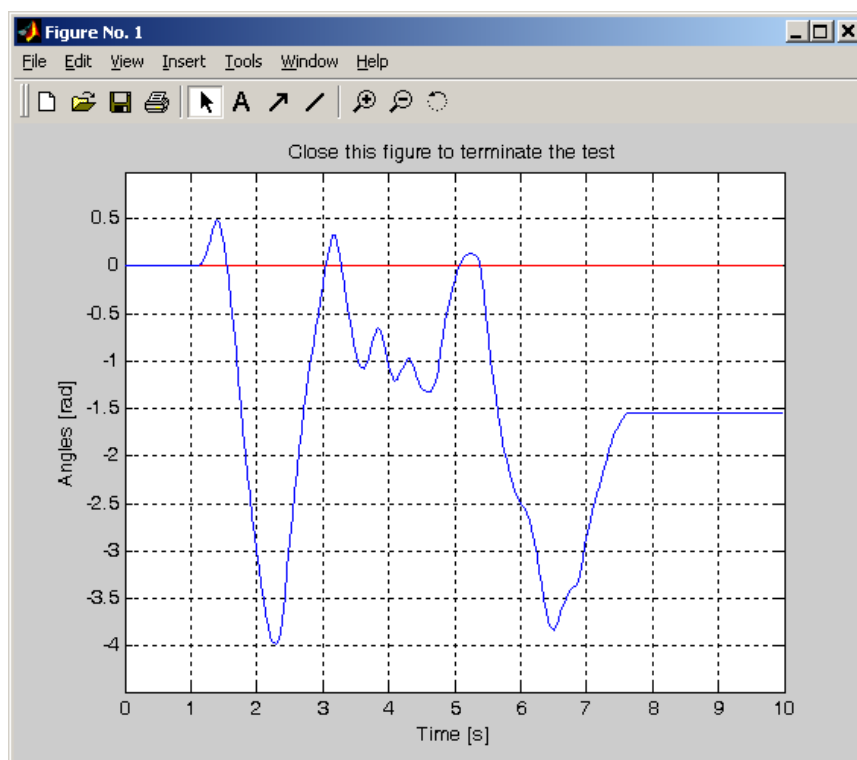

Fig. 2.5 Angle measurement test

- To check whether the potentiometer works correctly double click the *Check Reference Pot* button. Next click the *Yes* and turn the potentiometer right and left.

Fig. 2.6 shows an example of the proper measurements of the potentiometer position.

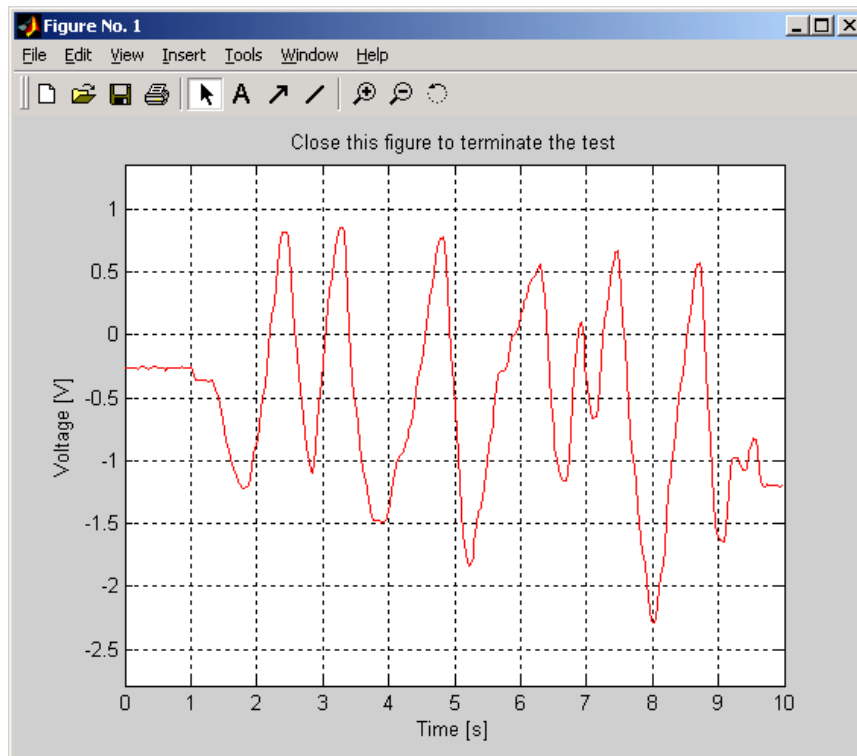
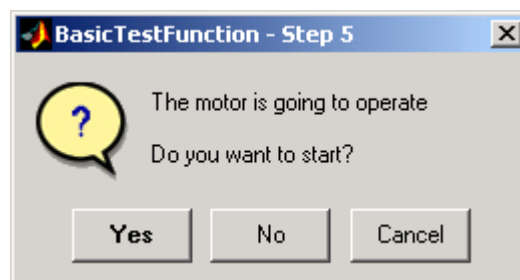

Fig. 2.6 Position of the reference potentiometer

In the next step of the basic tests one can check whether the control and measurements of the angle and velocity in MSS are correct. This experiment is not performed in real-time mode.

- Double click the *Control Impulse Response* button and start experiment clicking the *Yes* button.



The results of experiments are shown in Fig. 2.7. The control impulse has a square wave form. The first part of the control signal is positive, and the second one is negative. Note that angle and velocity signals are positive at the beginning and next fall down to the negative values. It means that the measurements are correct.

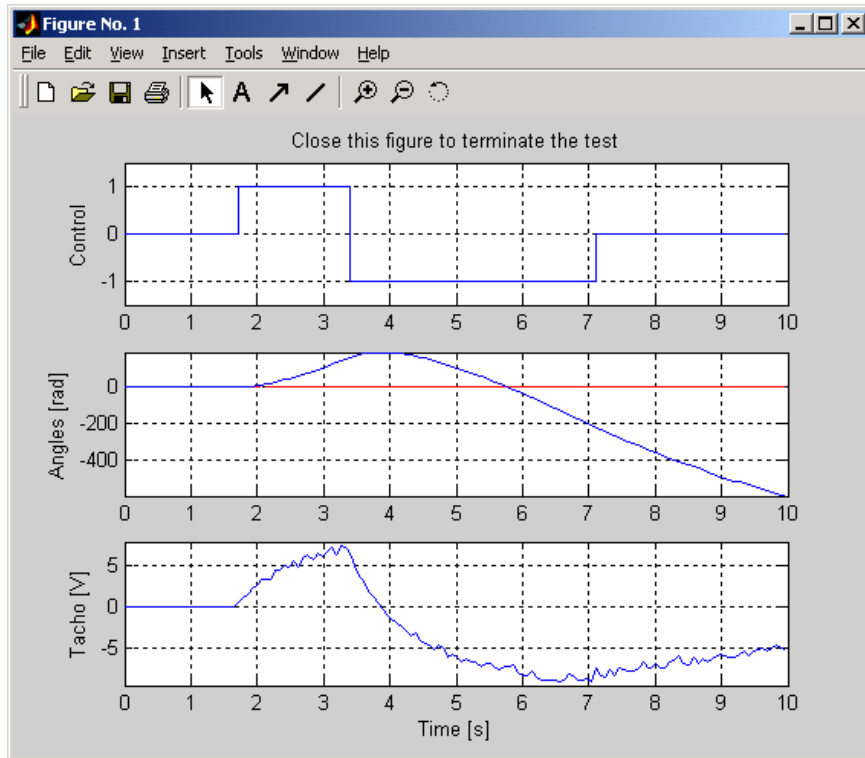

Fig. 2.7 The response of the system

3. Servo Control Window

The user has a quick access to all basic functions of the modular servo control system from the *Servo Control Window*. It includes tests, drivers, models and application examples.

Type at the Matlab prompt *servo* command and *Servo Control Window* shown in Fig. 2.1 opens. Simultaneously *start.m* m-file is executed which set the default values of the coefficients of the MSS: $K_s = 186$ [rad/s] and $T_s = 1.04$ [s]. Also the sampling time T_0 is set equal to 0.002 [s].

The window contains four groups of the menu items:

- Tools - Basic Test, Manual Setup, Reset Encoders and Stop Experiment,
- Drivers - RTWT Device Driver,
- Simulation Models: linear and nonlinear,
- Identification - Basic Measurements, Steady-State Characteristics and Time Domain Identification,
- Demo Controllers –PID Controller and State Feedback Controller applied to a position control and PID controller applied to a velocity control.

3.1. Basic test

The *Basic Test* tool was described in the previous section.

3.2. Manual setup

The *Servo Manual Setup* program gives access to the basic parameters of the laboratory modular servo setup. The most important data transferred from the RT-DAC/PCI board and the measurements of the servo may be visualised. Moreover, the control signals can be set. Double click the *Manual Setup* button and the screen shown in Fig. 3.1 opens.

The application contains four frames:

- RT-DAC/PCI board,
- Encoders,
- Control and
- Analog inputs.

All data presented by the *Servo Manual Setup* program are updated 10 times per second.

• RT-DAC/PCI board frame

The *RT-DAC/PCI board* frame presents the main parameters of the RT-DAC/PCI I/O board.

No of detected boards

Presents the number of detected RT-DAC/PCI boards. If the number is equal to zero it means that the software has not detect any RT-DAC/PCI board. When more then one board is detected the *Board* list must be used to select the board that communicates with the MSS control program.

Board

Contains the list applied to select the board currently used by the program. The list contains a single entry for each RT-DAC/PCI board installed in the computer. A new selection at the list automatically changes values of the remaining parameters.

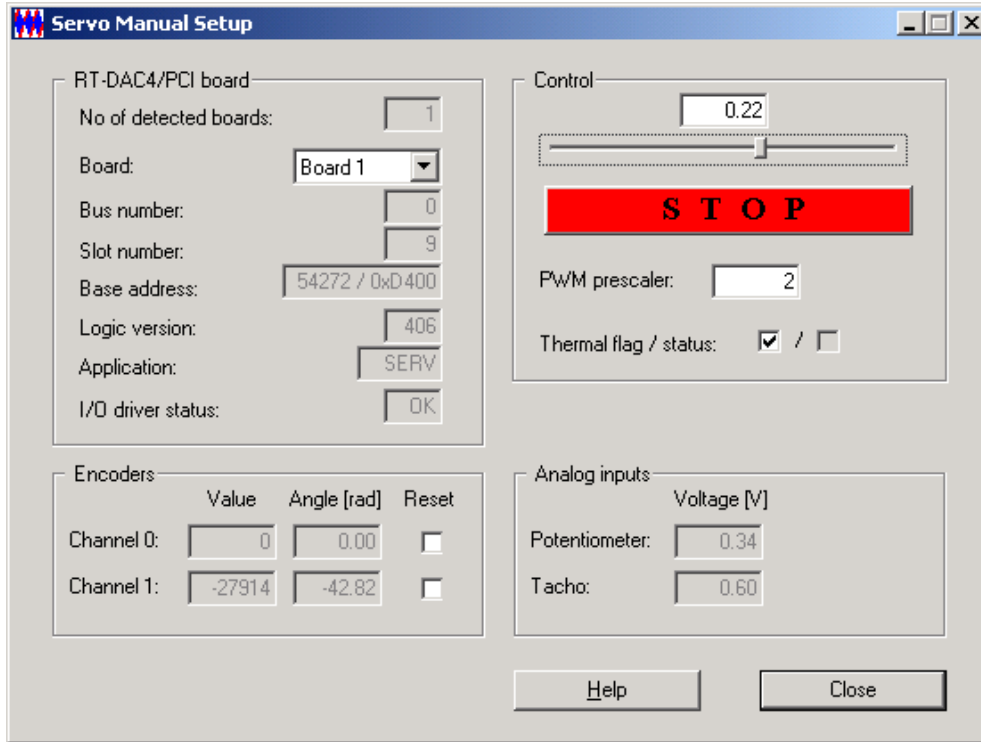

Fig. 3.1 View of the *Servo Manual Setup* window

Bus number

Displays the number of the PCI bus where the current RT-DAC/PCI board is plugged-in. The parameter may be useful to distinguish boards, when more then one board is used.

Slot number

The number of the PCI slot where the current RT-DAC/PCI board is plugged-in. The parameter may be useful to distinguish boards, when more then one board is used.

Base address

The base address of the selected RT-DAC/PCI board. The RT-DAC/PCI board occupies 256 bytes of the I/O address space of the microprocessor. The base address is equal to the beginning of the occupied I/O range. The I/O space is assigned to the board by the computer operating system and may differ from one computer to another.

The base address is given in the decimal and hexadecimal forms.

Logic version

The number of the configuration logic of the on-board FPGA chip. A logic version corresponds to the configuration of the RT-DAC/PCI boards defined by this logic.

Application

The name of the application the board is dedicated for. The name contains four characters. In the case of the MSS it has to be *SERV* string.

I/O driver status

The status of the driver that allows the access to the I/O address space of the microprocessor. The status displayed has to be *OK* string. In other case the driver HAS TO BE INSTALLED.

- **Encoders frame**

The state of the encoder channels is given in the *Encoder* frame.

Channel 0, Channel 1

The values of the encoder counters, the angles expressed in radians and the encoder reset flags are displayed in the *Channel 0* and *Channel 1* row. In this version MSS may use a single encoder module. In such a case only one channel presents the current data.

Value

The values of the encoder counters are given in the respective columns. The values are 24-bit integer numbers. When an encoder remains in the reset state the corresponding value is equal to zero.

Angle [rad]

The angular positions of the encoders expressed in radians are given in the respective columns. When the encoder remains in the reset state the corresponding angle is equal to zero.

Reset

When the checkbox is selected the corresponding encoder remains in the reset state. The checkbox has to be unchecked to allow the encoder to count the position.

- **Control frame**

The *Control* frame allows to change the control signal.

Edit field, slider

The control edit box and the slider are applied to set a new control value. The control value may vary from -1.0 to 1.0.

STOP

The pushbutton is applied to switch off the control signal. When pressed the control value is set to zero.

PWM prescaler

The divider of the PWM reference signal. The frequency of the PWM control is equal to:

$$f_{pwm} = \frac{40}{(1 + PWMprescaler)} [KHz]$$

Thermal flag / status

The thermal flag and the thermal status of the power amplifier. If the thermal status box is checked the power interface is overheated. If the thermal flag is set and the power interface is overheated the RT-DAC/PCI board automatically switches off the PWM control signal.

- **Analog inputs frame**

The *Analog inputs* frame displays two measured analog signals.

Potentiometer

Presents the voltage at the output of the potentiometer block.

Tacho

Presents the voltage at the output of the tachogenerator.

3.3. RTWT Driver

The main driver is located in the *RTWT Device Driver* column. The driver is a software “go-between” for the real-time MATLAB environment and the RT-DAC/PCI I/O board. This driver serves the control and measurement signals. Click the *Modular Servo Device Driver* button and the driver window opens (Fig. 3.2).

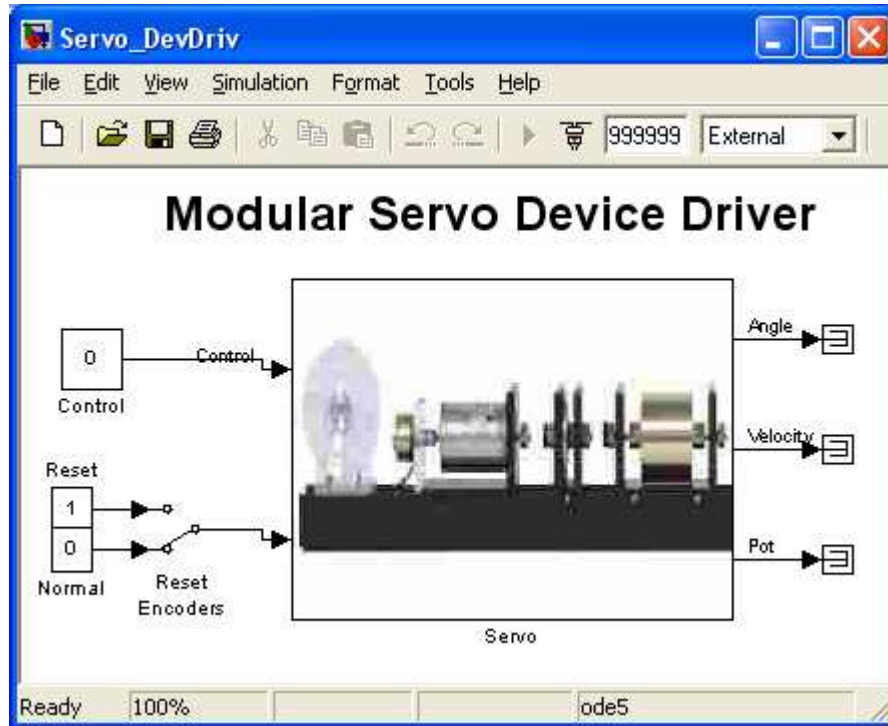



Fig. 3.2 RTWT Device Driver

When one wants to build his own application he has to copy this driver to a new Simulink diagram.

 **Do not introduce changes inside the original driver. They can be done only inside its copy!**

The device driver has two inputs: control $u(t) \in [-1+1]$ and signal *Reset*. If the *Reset* signal changes to one the encoders are reset and do not work. If the *Reset* signal is equal to zero encoders work in the standard way. It means when switching occurs, encoders reset and start measure when the switch returns to the zero (normal) position. It is important that the *Reset* switch works only when the real-time code is executed.

The mask of the *Servo* block (presented in Fig. 3.3) contains base address of the RT-DAC/PCI board (automatically detected with the help *RTDACPCIBaseAddress* function) and the sampling period which default value is set to 0.002 sec. If one wants to change the default sampling time he must do it in this mask also.

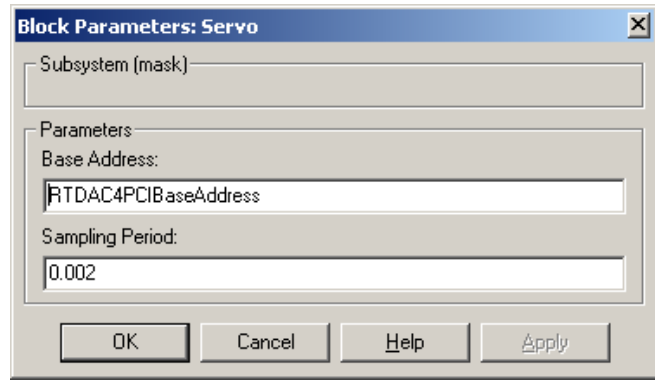

Fig. 3.3 Mask of the device driver

The details of the device driver are depicted in Fig. 3.4. The driver uses functions which communicates directly with a logic applied at the RTDAC/PCI board. Notice, that the driver is ready to use a second (optional) encoder, as well.

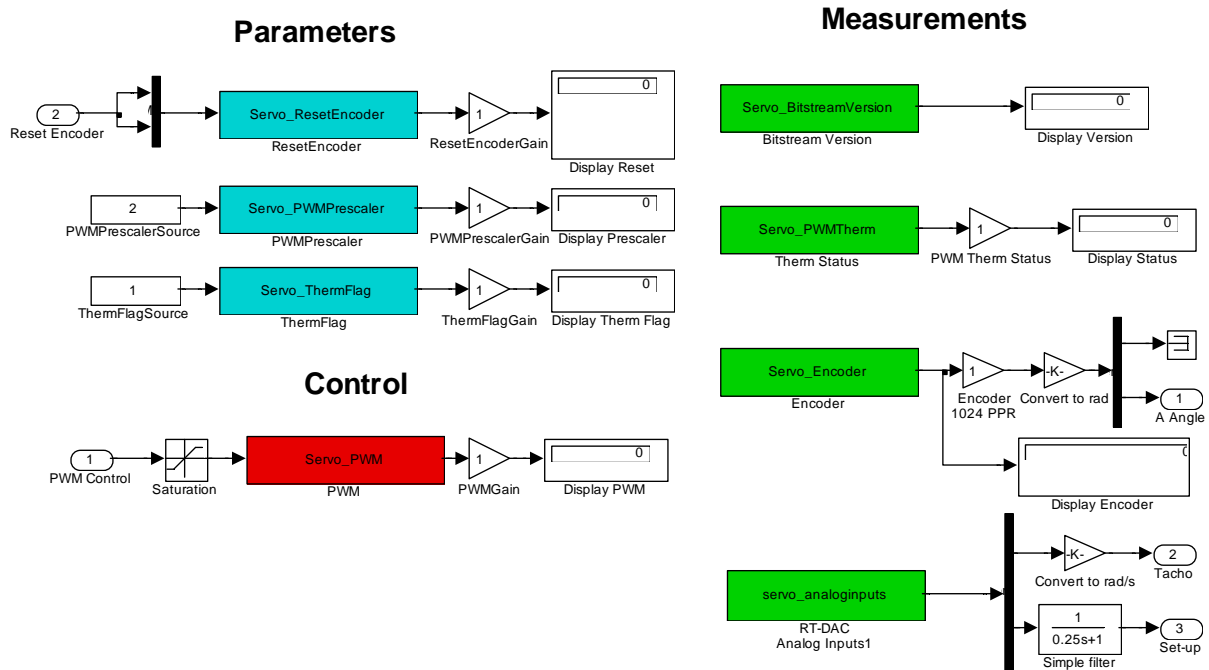

Fig. 3.4 Interior of the RTWT device driver

3.4. Simulation Models

There are two simulation models available for the servo system. The first one is a linear model and the second one is nonlinear. The linear model is used to design controllers. The nonlinear model is used to check the quality of the designed control system.

Linear and Nonlinear Simulation Model – the simulation models of the servo are located under these buttons. The external view of the simulation models is identical as the model described in the *Modular Servo Device Driver* except the *Reset Encoder* input and reference *Potentiometer* output which are not used in the simulation mode.

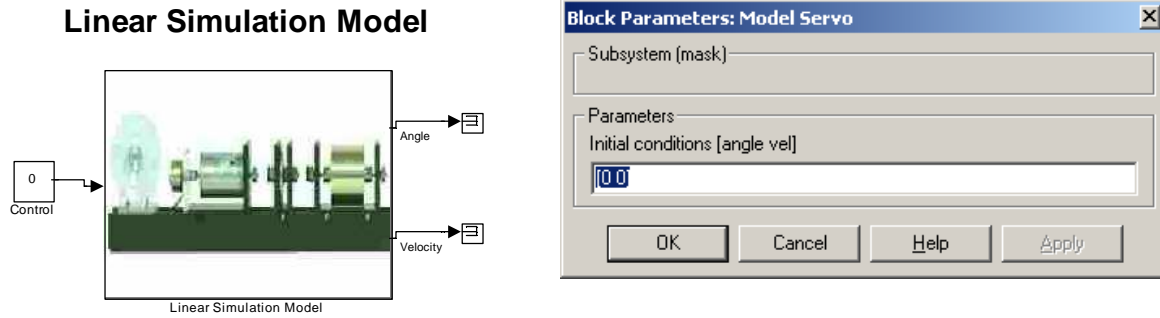

Fig. 3.5 Linear Simulation Model and its mask

The vector of the initial conditions of the state variables of the simulation model is the parameter available in the mask.

➔ The model has no constrained control (as in the case of the real servo system). If you use the linear simulation model in a closed-loop remember that control should satisfy $|u| \leq 1$. You can include the *Saturation* block to limit the control.

In the case of the nonlinear simulation model two additional parameters appear. The gain of the model and the vector which contains the static characteristics of the servo system. Refer to section 4 for the details.

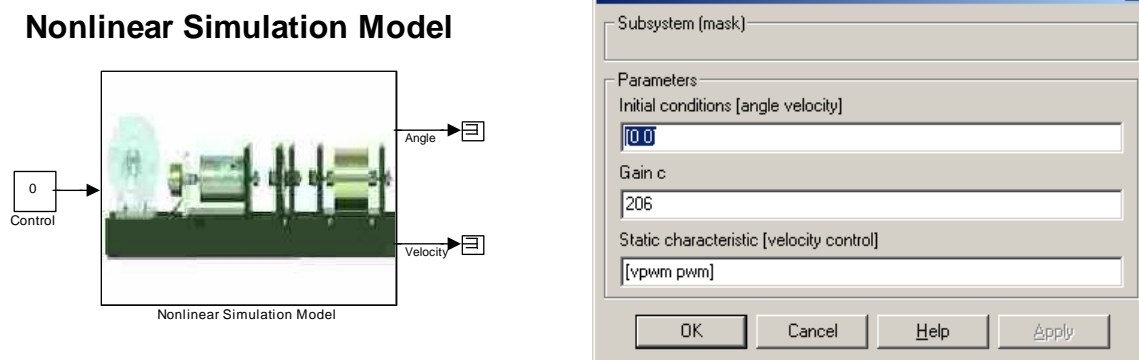

Fig. 3.6 Nonlinear Simulation Model and its mask

The simulation models are running in the normal simulation mode.

➔ Choose *Fixed step* solver options and set *Fixed-step size* equal to 0.002. It is necessary because the default value of the sampling time of all real-time models is equal to 0.002 [s].

3.5. Identification

The consecutive buttons in the group *Identification* of the *Servo Control Window* perform the following tasks:

Basic Measurements – contains a real-time Simulink model where a saw shape control signal is given as the input of the servo system and four velocities are plotted in a scope:

- measurements reconstructed from encoder,
- measurement directly from tachogenerator,
- filtered tachogenerator voltage using low pass Butterworth filter,
- filtered tachogenerator voltage using simple first order filter.

The experiment allows to decide which kind of velocity measurements can be used in following experiments.

Plot basic measurements push button - activates the *plot_basic.m* file to plot measurements visible in the scope in the previous experiment.

Static Characteristics - performs experiment aimed to measure of the static characteristics of the loaded DC motor (angular velocity [rad/s] vs. input voltage [dimensionless] in the steady state). The characteristics can be measured for the servo system with or without magnetic brake module. The measurements are stored in the *ChStat.mat* file.

Plot & Save Characteristics - uses *plot_stat.m* file which plots measured characteristics, performs some normalisations of the data, and saves characteristics in *servo_chstat.mat* file.

Time Domain Identification – opens the real-time Simulink model which starts identification based on a step system response.

The button *Identify Model* - takes advantage of identification data and calculates coefficients of a linear model of the servo system. The surface method is applied by the identification procedure.

3.6. Demo Controllers

The respective buttons in the column *Demo Controllers* perform the following tasks:

Position control

PID Control Continous - contains the Simulink model for real-time experiments in closed-loop with PID position controller, and simulation model of the PID controlled servo system.

State Feedback Control - opens the Simulink model to start real-time experiments for closed-loop system with state feedback. This model can be used for experiments with LQ or deadbeat controllers. Also simulation model of the closed-loop system is included under this button.

All the Simulink models mentioned above are examples of position control problems.

Calculate LQ controller – uses *Servo_calc_lq.m* file to obtain state feedback controller coefficients by solving the appropriate LQ problem. In the *Servo_calc_lq.m* file one can set matrices of the objective function to obtain appropriate behaviour of the system.

Velocity control

PID Controller - opens the Simulink model to start-real time experiments for the closed-loop system with velocity PID controller.

4. Mathematical model of the servo system

4.1. Linear Model

A DC motor with a negligible armature inductance (Fig. 4.1)

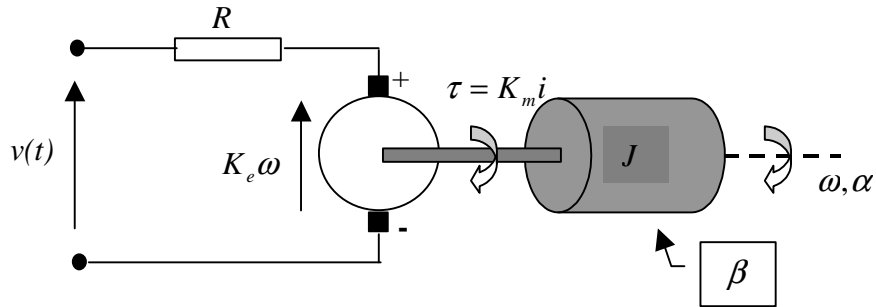

Fig. 4.1 Diagram of the DC motor

is described by two classical equations: electrical

$$v(t) = R i(t) + K_e \omega(t)$$

and mechanical

$$J \dot{\omega}(t) = K_m i(t) - \beta \omega(t)$$

where:

- $v(t)$ is the input voltage,
- $i(t)$ is the armature current,
- $\omega(t)$ is the angular velocity of the rotor,
- R is the resistance of the armature winding,
- J is the inertia moment of the moving parts,
- β is the damping coefficient due to the viscous friction,
- $K_e \omega(t)$ is the back EMF,
- and $\tau = K_m i(t)$ is the electromechanical torque.

This model is linear because the static and dry kinetic friction, as well as the saturation are neglected. By combining the electrical and mechanical equations we obtain the equation of a first order inertial system

$$T_s \dot{\omega}(t) = -\omega(t) + K_{sm} v(t)$$

where the motor time constant T_s and motor gain K_{sm} are given by

$$T_s = \frac{RJ}{\beta R + K_e K_m}, \quad K_{sm} = \frac{K_m}{\beta R + K_e K_m}.$$

The transfer function has the form

$$G(s) = \frac{\omega(s)}{v(s)} = \frac{K_{sm}}{T_s s + 1}$$

The transfer function for the motor position has the form:

$$G(s) = \frac{\alpha(s)}{v(s)} = \frac{K_{sm}}{s(T_s s + 1)}$$

The control applied in the system is a PWM signal that's way we assume the dimensionless control signal as the scaled input voltage $u(t) = v(t)/v_{\max}$. The admissible controls satisfy

$$|u(t)| \leq 1.$$

Defining also $K_s = K_{sm} v_{\max}$ we obtain transfer functions in the forms:

Velocity transfer function	Angle transfer function
$G(s) = \frac{\omega(s)}{u(s)} = \frac{K_s}{T_s s + 1}$	$G(s) = \frac{\alpha(s)}{u(s)} = \frac{K_s}{s(T_s s + 1)}$

The model can be written using a state space notation. Let $x = \text{col}(x_1, x_2)$ be the state vector where x_1 is the angle α (in [rad]) determining the position of the motor shaft, and $x_2 = \omega$ is the respective angular velocity (in [rad/s]). Time t is measured in [s].

There are the following state equations

$$\begin{aligned} \dot{x}_1 &= x_2 \\ \dot{x}_2 &= ax_2 + bu \end{aligned}$$

where

$$a = -\frac{1}{T_s} < 0, \quad b = \frac{K_s}{T_s} > 0.$$

The equivalent classical matrix state space notation has the form

$\begin{aligned} \dot{x} &= Ax + Bu \\ y &= Cx \end{aligned}$	<p>where:</p> $A = \begin{bmatrix} 0 & 1 \\ 0 & -\frac{1}{T_s} \end{bmatrix}, \quad B = \begin{bmatrix} 0 \\ \frac{K_s}{T_s} \end{bmatrix}, \quad C = I.$
---	---

The system can be classified as a multivariable (SIMO) because it has two measurable state variables and one control variable. The parameters T_s and K_s must be identified by a user.

The default values assumed for identification experiments are as follows: $v_{\max} = 12$ [V], $T_s = 1.04$ [s], $K_s = 186$ [rad/s], which gives $a = -0.961$ [s⁻²], and $b = 178.8$ [rad/s²].

These values have been identified by the manufacturer for the DC motor with the tachogenerator loaded by the inertia module and connected to the gearbox module equipped with the output disk.

4.2. Nonlinear model

Very often small changes of the state variables are assumed. Therefore, the control system can be considered as a linear one. However, in some applications nonlinearities in the control loop have to be taken into account. This includes non-linear static characteristics such as hysteresis and saturation, which may occur if the following devices are applied: operational amplifiers, actuators, finite word length in A/D and D/A converters. Often the signal constraint first appears for the control variable. We will assume a nonlinear model of the DC motor in the form

$$\begin{aligned}\dot{x}_1 &= x_2 \\ \dot{x}_2 &= c(u - g(x_2))\end{aligned}$$

where the state variables x_1 , x_2 and control u are defined as in the linear model.

The function g is the inverted steady state characteristics of the system, which can be determined experimentally (see section 6.2). The original steady state characteristics (see Fig. 6.8) is obtained from measurements. The results of measurements undergo a preliminary treatment consisting of scaling (to express them in appropriate units) and a shift (to remove the bias). The function g is presented in Fig. 4.2. An interesting property of the g function is that it is discontinuous at zero and shows distinct effects of dry friction in a vicinity of the origin.



The static characteristics was obtained for the system consisting of DC motor, inertia load, encoder and gearbox modules. If a magnetic break module is added to the system a measured characteristics are quite different.

The c coefficient was identified and $c = 206$ [rad/s].

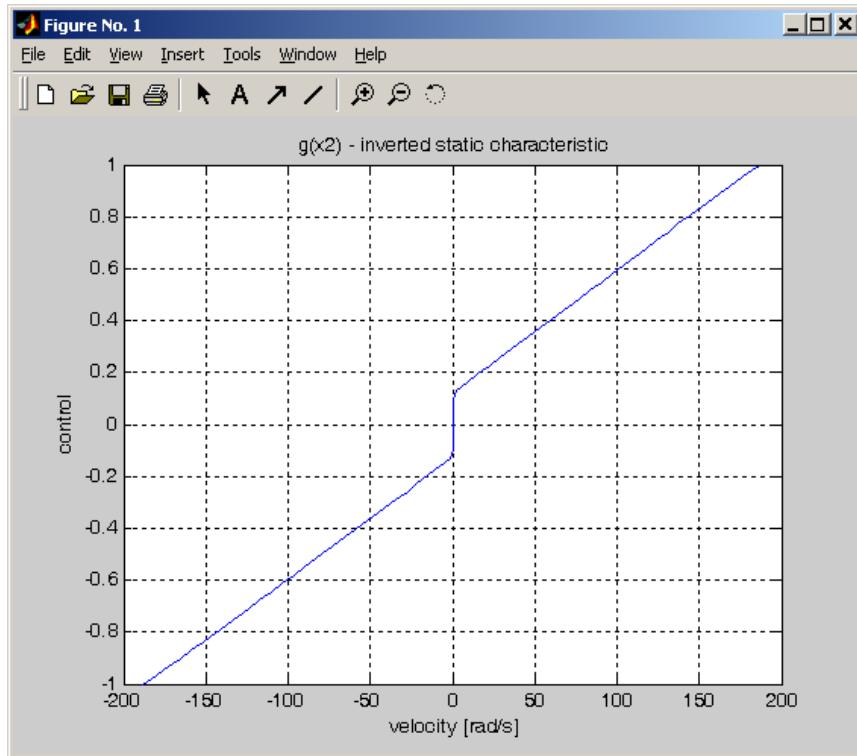

Fig. 4.2 Function $g(x_2)$ is the inverted static characteristics of the servo

5. RTWT model

In this section the process of building your own control system is described. The *Real Time Windows Target* (RTWT) toolbox is used. An example how to use the MSS software will be shown in section 6. In this section some hints how to proceed in the RTWT environment are given.



Before start, test your MATLAB configuration by building and running an example of real-time application. Real-time Windows Target Toolbox includes the *rtvdp.mdl* model. Running this model will test the installation by running Real-Time Workshop, Real-Time Windows Target, and the Real-Time Windows Target kernel.

In the MATLAB window, type

rtvdp

Next, build and run the real-time model.

To build the control application that operates in the real-time mode the user has to:

- create a Simulink model of the control system which consists of the *Modular Servo Device Driver* and other blocks selected from the Simulink library,
- build the executable file under RTWT,
- start the real-time code to run from the *Simulation/Start real-time code* pull-down menus.

5.1. Creating a model

The simplest way to create a Simulink model of the control system is to use one of the models available from the *Servo Control Window* as a template. For example, click on the *Basic Measurements* button and save it as *MySystem.mdl* name. The *MySystem* Simulink model is shown in Fig. 5.1.

Now, you can modify the model. You have absolute freedom to modify the model and to develop your own control system. Remember to leave the *Servo driver* block in the window. This is necessary to work in RTWT environment.

Though it is not obligatory, we recommend you to leave the scope. You need a scope to watch how the system runs. The saturation blocks are built in the *Servo driver* block. They limit currents to DC motor for safety reasons. However they are not visible for the user who may amaze at the saturation of controls. Other blocks remaining in the window are not necessary for our new project.

Creating your own model on the basis of an old example ensures that all-internal options of the model are set properly. These options are required to proceed with compiling and linking in a proper way. To put the *Servo Device Driver* into the real-time code a special make-file is required. This file is included in the MSS software.

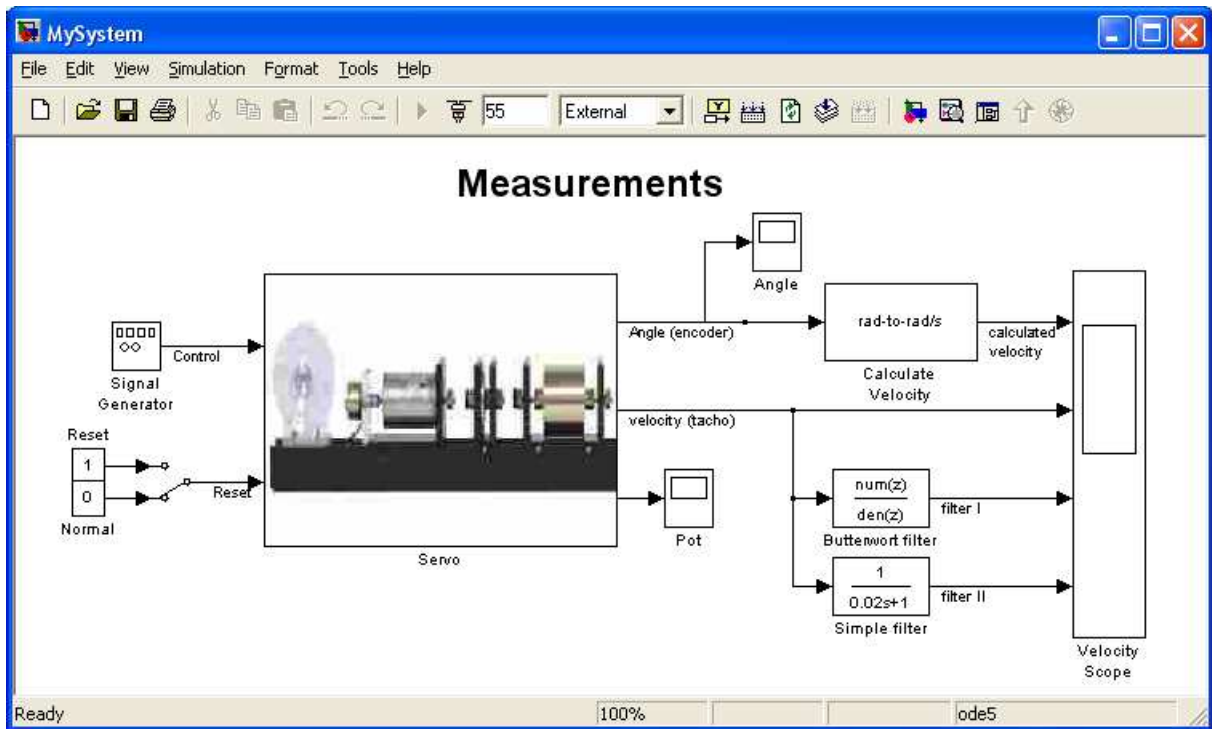

Fig. 5.1 The *MySystem* Simulink model

You can apply most of the blocks from the Simulink library. However, some of them cannot be used (see RTW or RTWT references manual).

The scope block properties are important for appropriate data acquisition and supervising how the system runs.

The *Scope* block properties are defined in the *Scope* property window (see Fig. 5.2). This window opens after the selection of the *Scope/Properties* tab. You can gather measurement data to the *Matlab Workspace* marking the *Save data to workspace* checkbox. The data is placed under *Variable name*. The variable format can be set as *structure* or *matrix*. The default *Sampling Decimation* parameter value is set to 1. This means that each measured point is plotted and saved. Often we choose the *Decimation* parameter value equal to 5. This is a good choice to get enough points to describe the signal behaviour and to save the computer memory. In this case the time space of the plot is equal to 0.01 [s].

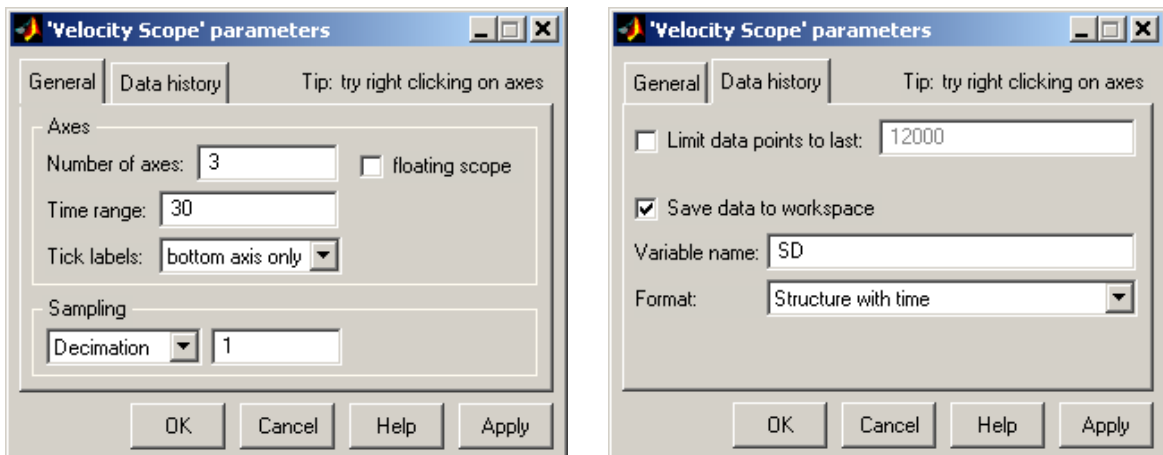

Fig. 5.2 Setting the parameters of the *Scope* block

When the Simulink model is ready, click the *Tools/External Mode Control Panel* option and next click the *Signal Triggering* button. The window presented in Fig. 5.3 opens. Select *Select All* check button, set *Source* as manual, set *Duration* equal to the number of samples you intend to collect and close the window.

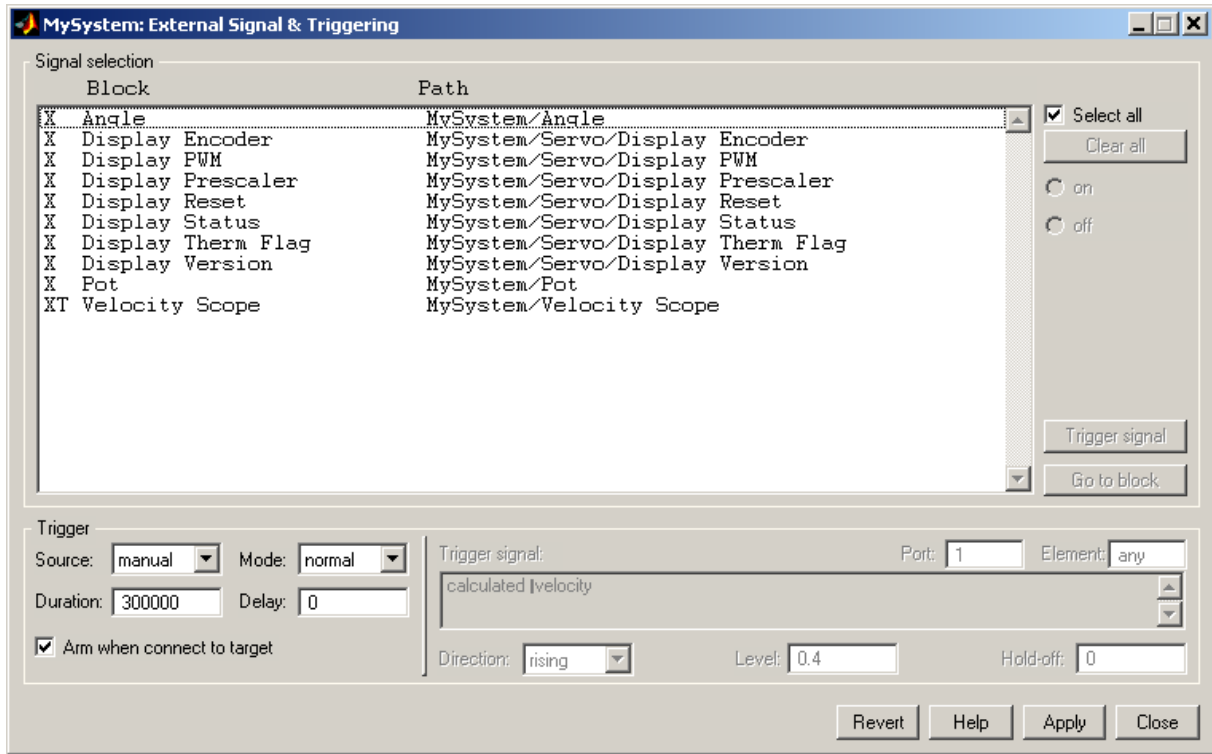

Fig. 5.3 *External Signal & Triggering* window

5.2. Code generation and the build process

Once a model of the system has been designed the code for real-time mode can be generated, compiled, linked and downloaded into the computer.

The code is generated by the use of Target Language Compiler (TLC) (see description of the Simulink Target Language). The make-file is used to build and download object files to the target hardware automatically.

First, you have to specify the simulation parameters of your Simulink model in the *Simulation parameters* dialog box. The RTW page appears when you select the *RTW* tab (Fig. 5.4). The *RTW* page allows you to set the real-time build options and then to start the building process of the executable file.

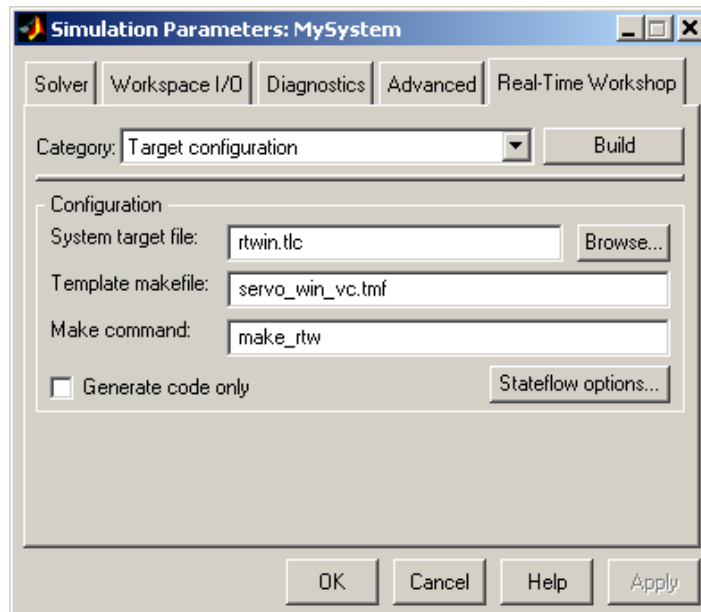

Fig. 5.4 RTW page of the *Simulation parameters* dialog box (MATLAB 6.5)

The system target file name is *rtwin.tlc*. It manages the code generation process. The *servo_win_vc.tmf* template make-file is devoted to C code generation using the Microsoft Visual C++ compiler. The *servo_win_watc.tmf* template file has to be applied if the Open Watcom 1.3 compiler is used.

If the Matlab 7.0.4 or higher version is used a third party compiler is not required. The built-in Open Watcom compiler is used to creating real-time executable code for RTWT.

The *Configuration parameters* page for MATLAB 7.04 is shown in Fig. 5.5. Notice that *rtwin.tmf* template makefile is used. This file is default one for RTWT building process.

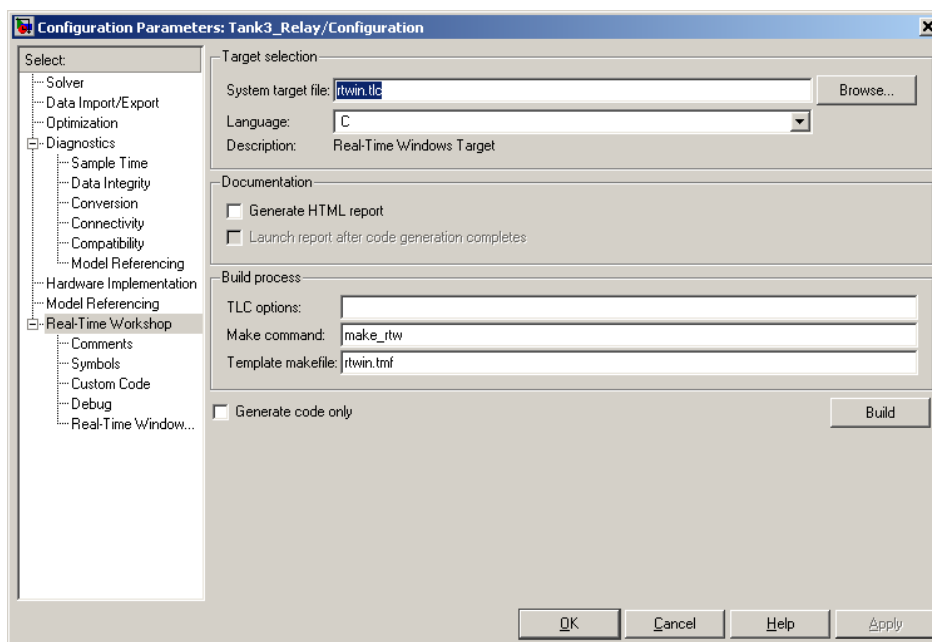

Fig. 5.5. *Configuration parameters* page for MATLAB 7.04 and higher versions

The *Solver* page appears when you select the *Solver* tab (Fig. 5.6). The *Solver* page allows you to set the simulation parameters. Several parameters and options are available in the window. The *Fixed-step size* editable text box is set to 0.002 (this is the sampling period in seconds).

➔ **The *Fixed-step* solver is obligatory for real-time applications. If you use an arbitrary block from the discrete Simulink library or a block from the driver library remember that different sampling periods must have a common divider.**

The *Start time* has to be set to 0. The solver has to be selected. In our example the fifth-order integration method – *ode5* is chosen.

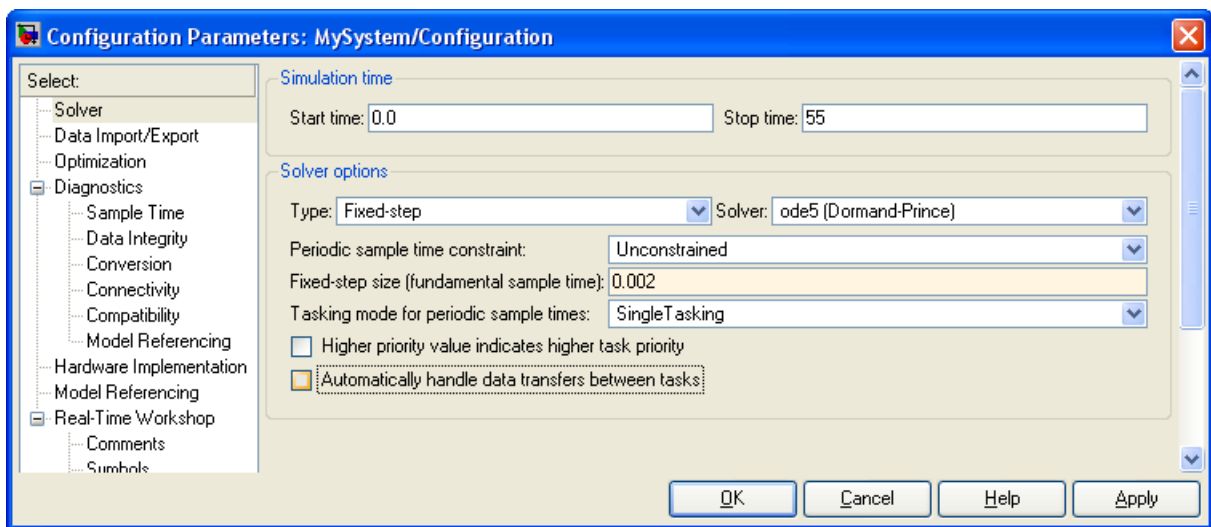

Fig. 5.6 Simulation parameters

If all parameters are set properly you can start the executable building process. For this purpose press the *Build* push button on the RTW page (Fig. 5.4).

Successful compilation and linking processes generate the following message:

```
### Created Real-Time Windows Target module MySystem.rwd.
### Successful completion of Real-Time Workshop build procedure for model: MySystem
```

Otherwise, an error message is displayed in the MATLAB command window.

6. Basic Assignments

All experiments described in this manual are performed with servo system consisting of the following modules: DC motor with tachogenerator, inertia load, encoder and gearbox with the output disk. In one experiment additionally the backlash module is applied.

6.1. Basic measurements

In this section quality of measurements in the servo system is concerned. The shaft angle is measured with high accuracy by an incremental encoder. If the tachogenerator is not used the shaft angular velocity must be reconstructed from the angle measurements. If the tachogenerator is used as a velocity sensor then its voltage signal comes together with disturbances, therefore it must be filtered.

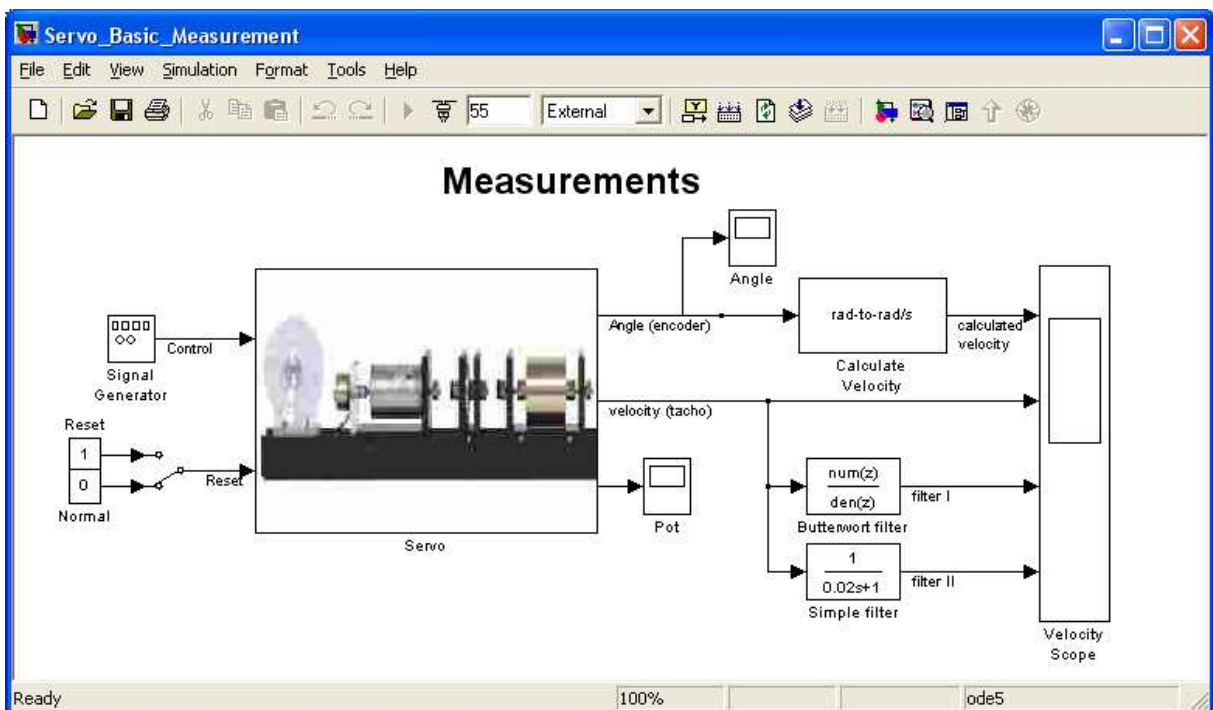

Fig. 6.1 Simulink model of *Basic Measurements*

The *Signal generator* block produces a saw shape control signal for the servo system. This shape was selected to demonstrate the full range of the control values.

The velocity measurements are shown in Fig. 6.2. One can see that the most disturbed is signal obtained directly from the tachogenerator. The reconstructed velocity (from encoder measurements of the angle) is the best one. Two types of the filters are applied: the fourth order Buterworth filter and a simple first order filter. Details and differences between the measurements are shown in Fig. 6.3 and Fig. 6.4. A user can choose which one of the velocity measurement will be used in his own real-time experiments.

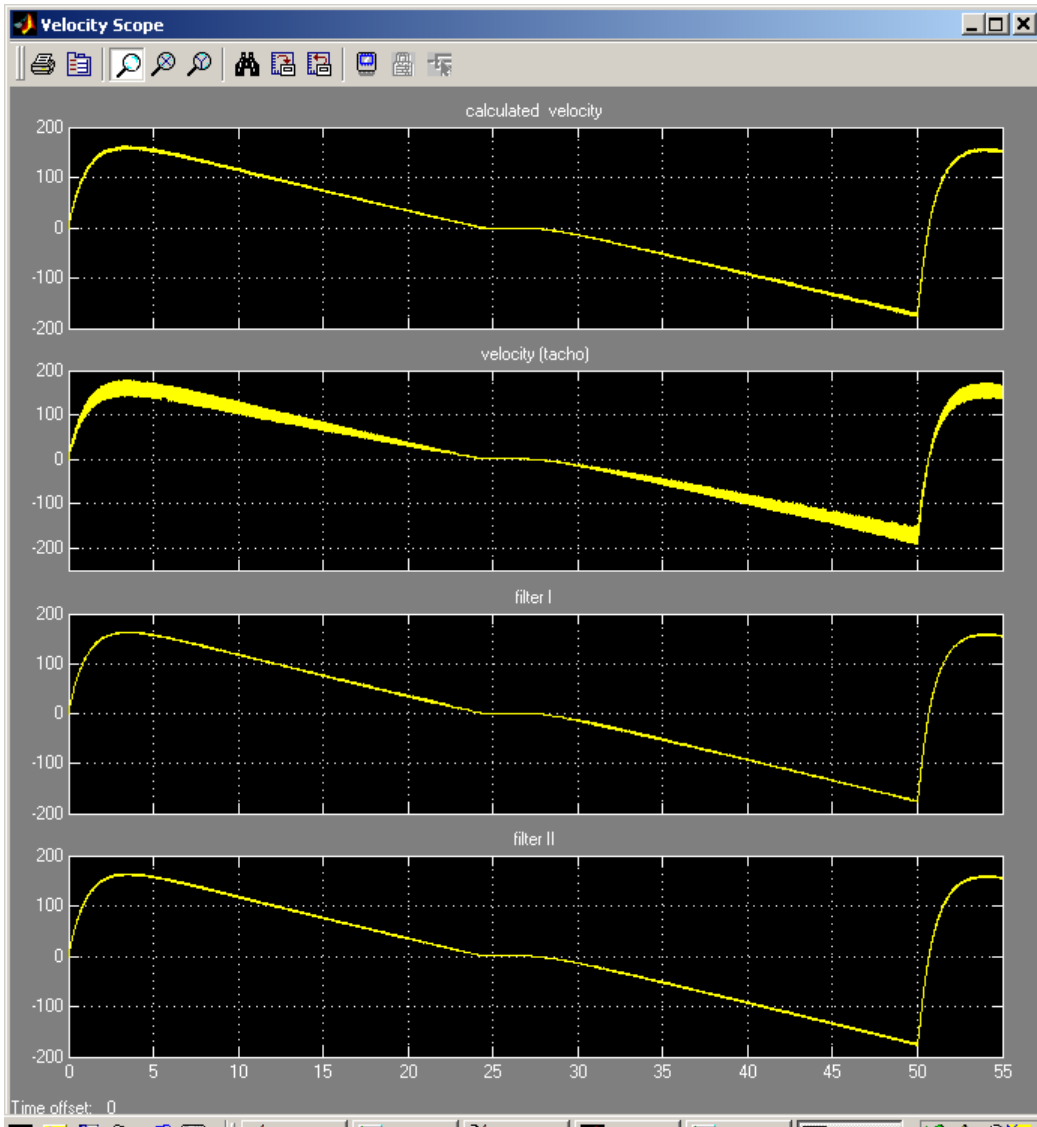

Fig. 6.2 Velocity measurements

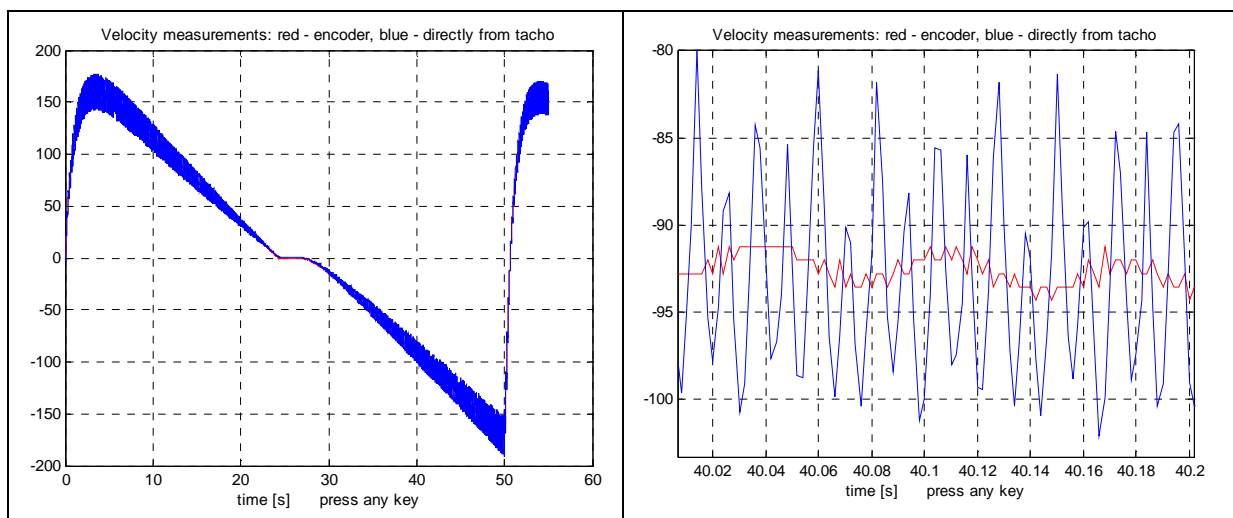

Fig. 6.3 Comparison of the velocity measurements

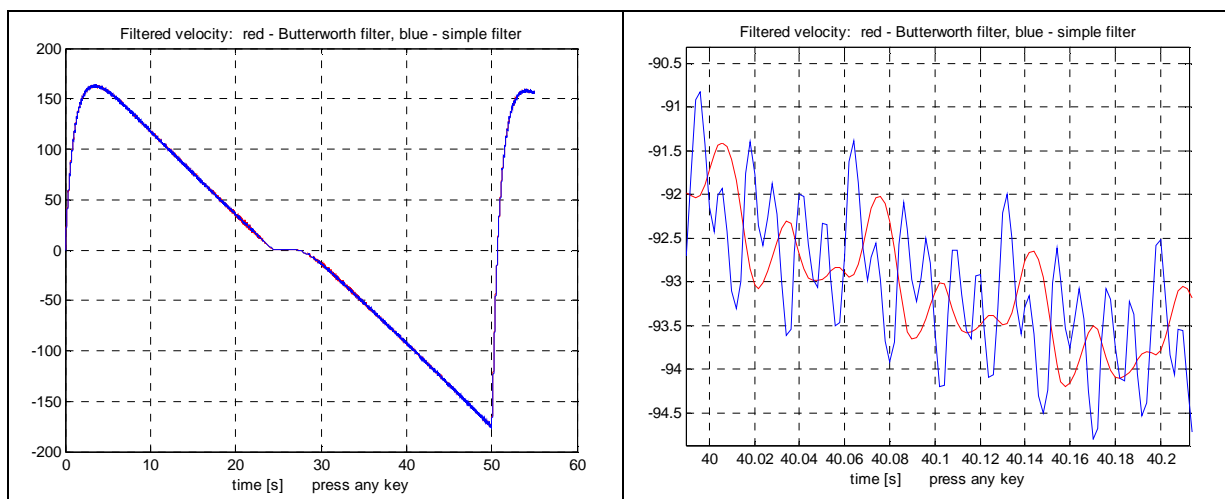

Fig. 6.4 Comparison of the velocity measurements

6.2. Steady state characteristics of the DC servo

Double click the *Static characteristics* button in *Servo Control Window*. The window given in Fig. 6.5 opens. In this window one defines the minimal and maximal control values and a number of measured points. Also the control order can be set as: *Ascending*, *Descending* or *Reverse*.

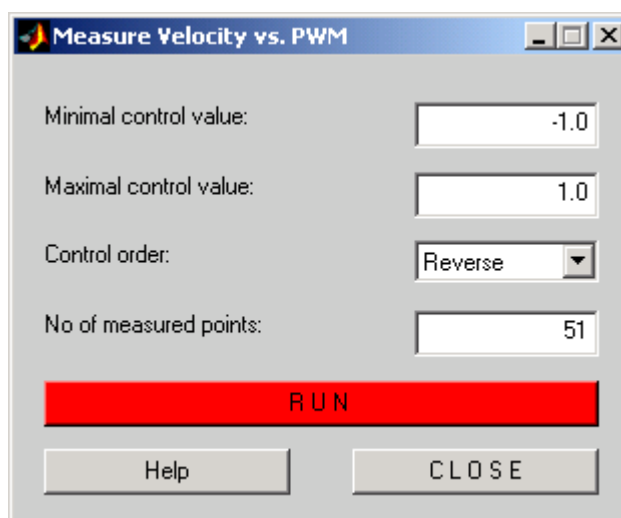

Fig. 6.5 Parameters of measurement of static characteristics

The *Run* button starts the experiment. The constant value of the control activates the DC motor so long as a steady state of the shaft angular velocity is achieved. Then, the velocity is measured and the control value is changed to the next constant value and DC motor is activated again. These steps are repeated to the end of the control range. Simultaneously, the measurements are displayed in the screen (see Fig. 6.6). There are two sources of DC motor velocity: the reconstruction from the incremental encoder pulses and the tachogenerator voltage. After the identification process the measurements are saved in the *ChStat.mat* file.

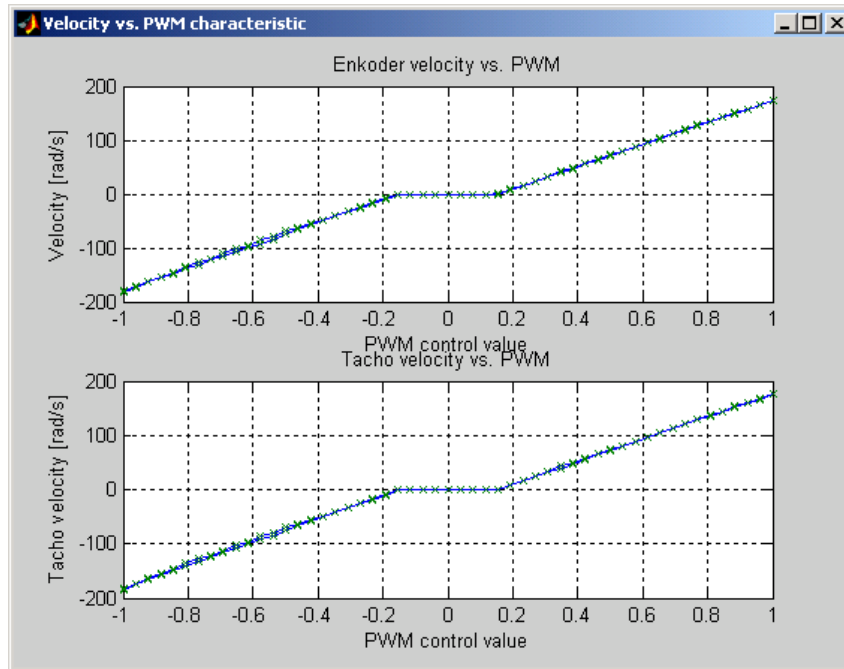

Fig. 6.6 Visualisation of measurements the static characteristic

When the measurements are completed, close the window and double click the *Plot & save* button. The *ChStat.mat* file is loaded and the static characteristics is plotted (see Fig. 6.7). Notice that when the characteristics is measured in *Reverse* mode (the control is changed from -1 to $+1$ and in the reverse order). The plots are slightly different. Next, the characteristics are averaged and shifted to zero for a number of points to diminish influence of the dry friction. Next, the plot (see Fig. 6.6) is drawn and the characteristic is saved in the *servo_chstat.mat* file. If this file exists it is overwritten.

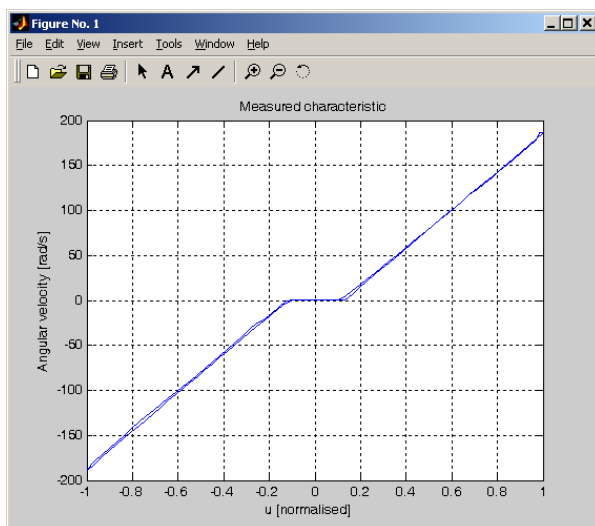

Fig. 6.7 Collecting points of the static characteristic

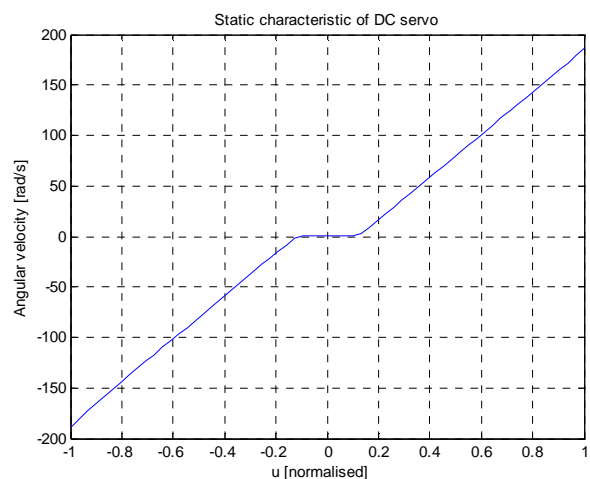

Fig. 6.8 Averaged and shifted static characteristic

Building a new static characteristics is a seldom operation. Please do not forget to save the old characteristics (with an appropriate description) in a safe place. The details are included in the *plot_stat.m* file which executes all operations mentioned above.

The characteristics saved in the *servo_stat.mat* file is used in the construction of a nonlinear model of the servo system.

6.3. Identification in time domain

The task is to find the parameters T_s and K_s of the linear model of the servo system described by the transfer function

$$G(s) = \frac{x_2(s)}{u(s)} = \frac{K_s}{T_s s + 1} \quad (6.1)$$

that the states of the model fit to the experimentally measured states. The step input signal $u(t) = \mathbf{1}(t)$ is applied to the servo system and the velocity vs. time is acquired. The surface method is applied to find the system parameters.

6.3.1. Identification task by the surface method

The velocity signal is denoted as $x_2(t)$. Applying the model (6.1) the required parameters K_s and T_s can be calculated using the following relations:

$$K_s = \lim_{t \rightarrow \infty} x_2(t), t \rightarrow \infty$$

$$T_s = \frac{K_1}{K_s} \quad \text{where } K_1 = \lim_{t \rightarrow \infty} \int_0^t (K_s - x_2(\lambda)) d\lambda, t \rightarrow \infty$$

The surface method is the useful identification algorithm in the presence of disturbances. In this case the integral formula filtrates the measurement noises. Fig. 6.9 shows a typical application of this method to a DC servo identification problem.

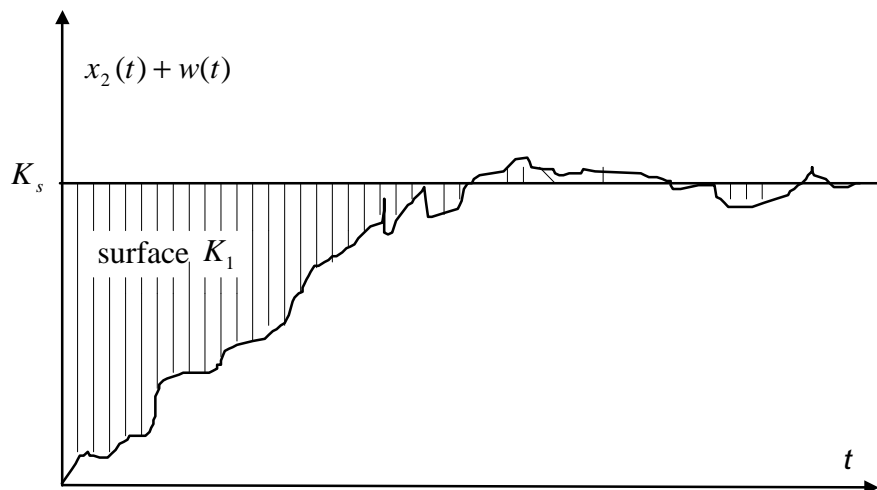

Fig. 6.9 Surface method in the presence of disturbances $w(t)$

6.3.2. Time domain identification experiment

In this experiment MSS includes the following modules: the DC motor with tachogenerator, inertia load, encoder module and gearbox module with the output disk. The magnetic break module can be added but in such a case the identified parameters of the system will be different.

To start the identification experiment type **servo** at the MATLAB prompt and *Servo Control Window* appears. Now, double click the *Time domain identification* button. The model shown in Fig. 6.10 opens.

Build model (in the case if it has not been done before). Next, select the *Simulation/Connect to target* option and click the *Simulation/Start real-time code*. The servo starts to move and one can observe the velocities displayed in the screen (see Fig. 6.11).

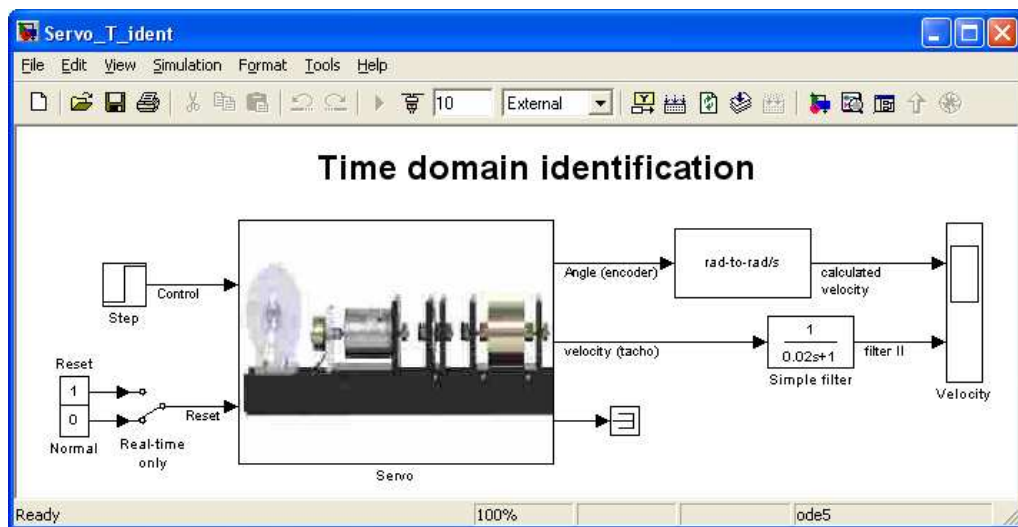

Fig. 6.10 Real-time Simulink model for identification

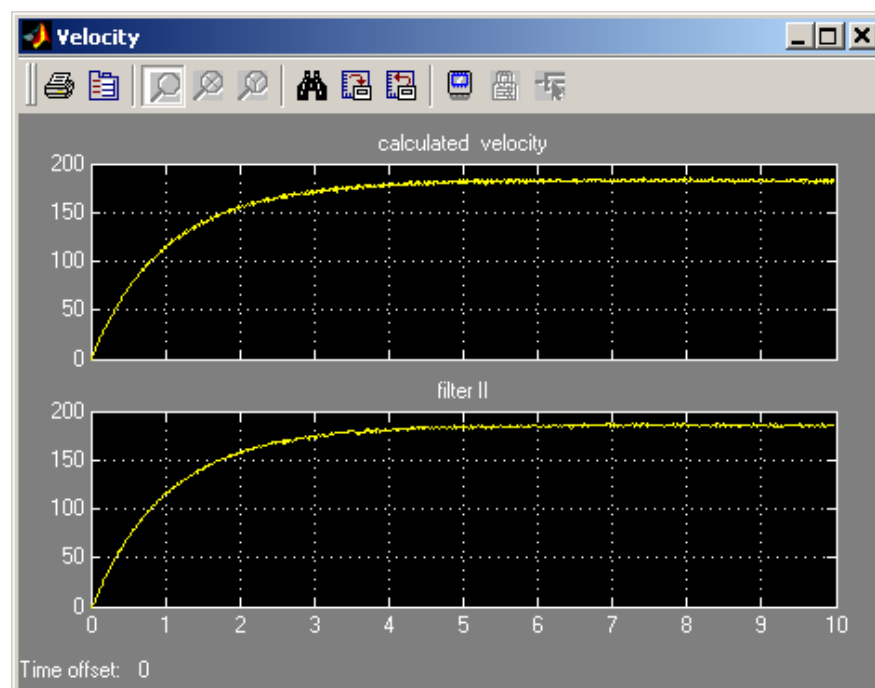

Fig. 6.11 Step response of the servo

Click the *Calculate model* button. This action starts the *plot_ident.m* file where the surface method is applied and the parameters of the servo model are calculated. Consequently, Fig. 6.12 opens and two plots are displayed in the screen:

- velocity obtained from the measurements (red),
- velocity calculated from the model (black).

At the top of the figure the obtained coefficients and the Mean square error denoted by J corresponding to data fitting are displayed. The coefficients are also displayed in the Matlab window.

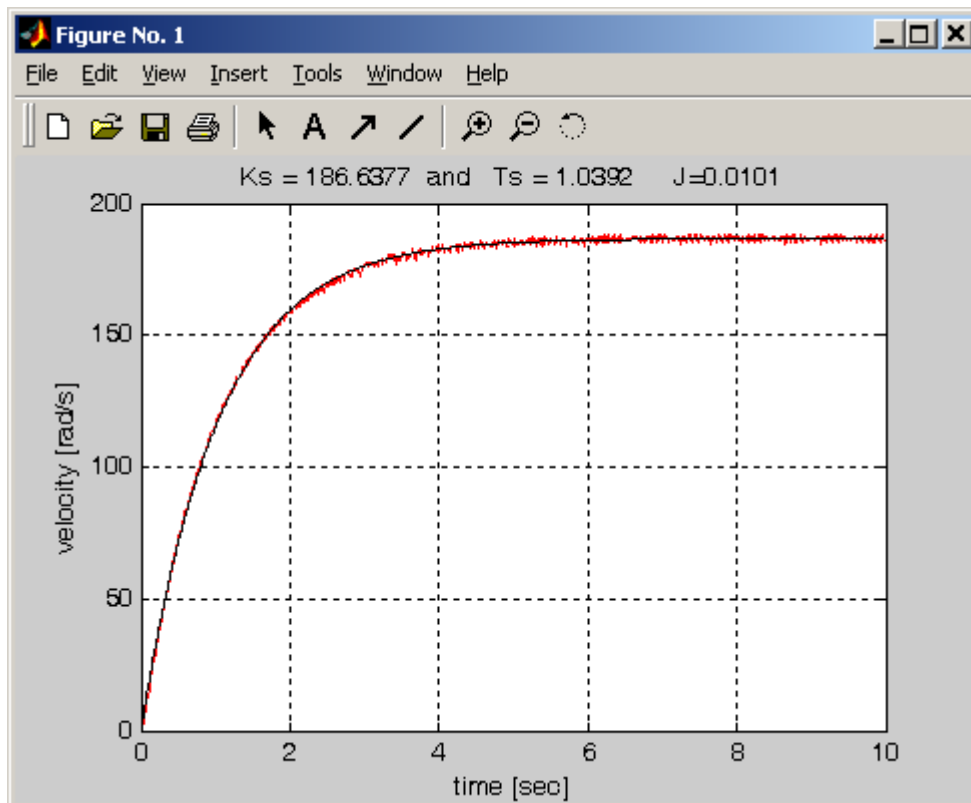

Fig. 6.12 Measured (red) and modelled (black) velocities



Remember that your servo can be different to the system described in this manual. The time domain identification has to be performed before any experiment.

7. Advanced Assignments

7.1. PID position control

A PID controller is the most common form of feedback. In process control today, more than 95% of the control loops are of a PID type, in principle a PI control. The PID controllers are today present in all areas where control is used. In our case only P and PD controllers are concerned. The servo itself behaves as an integrator.

In this section a problem of the position control of the servo is concerned. The background to simple tuning methods is introduced.

All real-time experiments related to the PID position control are performed using the model given in Fig. 7.1.

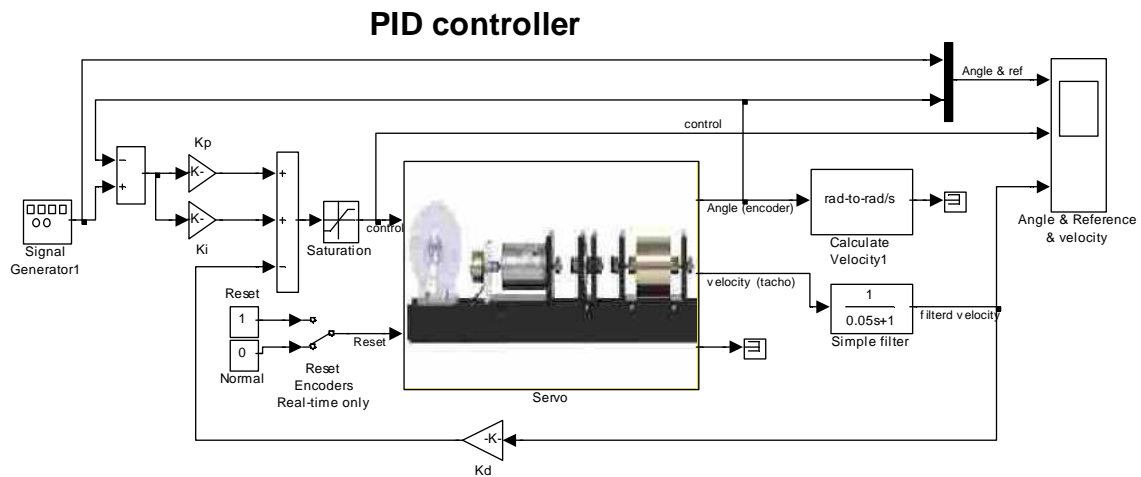

Fig. 7.1 Real-time model of the servo with the PID controller

The transfer function of a continuous PID controller used in this manual has the form:

$$K(s) = \frac{u(s)}{\varepsilon(s)} = K_p + \frac{K_I}{s} + sK_D$$

where: ε - error ,

K_p - proportionality coefficient, K_I - integration coefficient and K_D - derivation coefficient.

P controller

A goal of the control is to track a reference signal which is defined as a square wave. In this section the P controller is investigated.

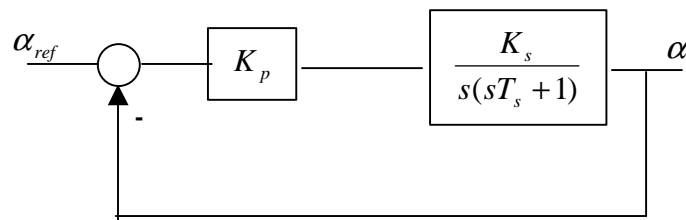

Fig. 7.2 Position servo control with the P controller

The diagram of the closed loop system is shown in Fig. 7.2. It is well known that increasing gain leads to oscillations. To test the real-time system for different gains of the P controller click *PID control continuous* button in *Servo Control Window*. The model given in Fig. 7.1 opens.

We start with a small value of the gain of the P controller. Type $K=[0.0064 \ 0 \ 0]$ at the MATLAB prompt. It set proportional coefficient K_p of the P controller. Assuming a desired range of the change of the output disk equal to $\pi/2$ set reference input signal equal to $25 \cdot \pi/2$ (it is the measured angle at the input to the gearbox). Also set frequency of the reference input to 0.05 Hz and sample time to 0.002 s.

- Build the model.
- Click the *Simulation/Connect to target* and *Start real-time code* options to start experiment.

Next, repeat the experiment for the new setting: $K_p = 0.0127$ and $K_p = 0.0254$.

The results of all experiments are given in Fig. 7.3 and Fig. 7.4. Note, that oscillations of the system response appear if $K_p = 0.0127$ and $K_p = 0.0254$.

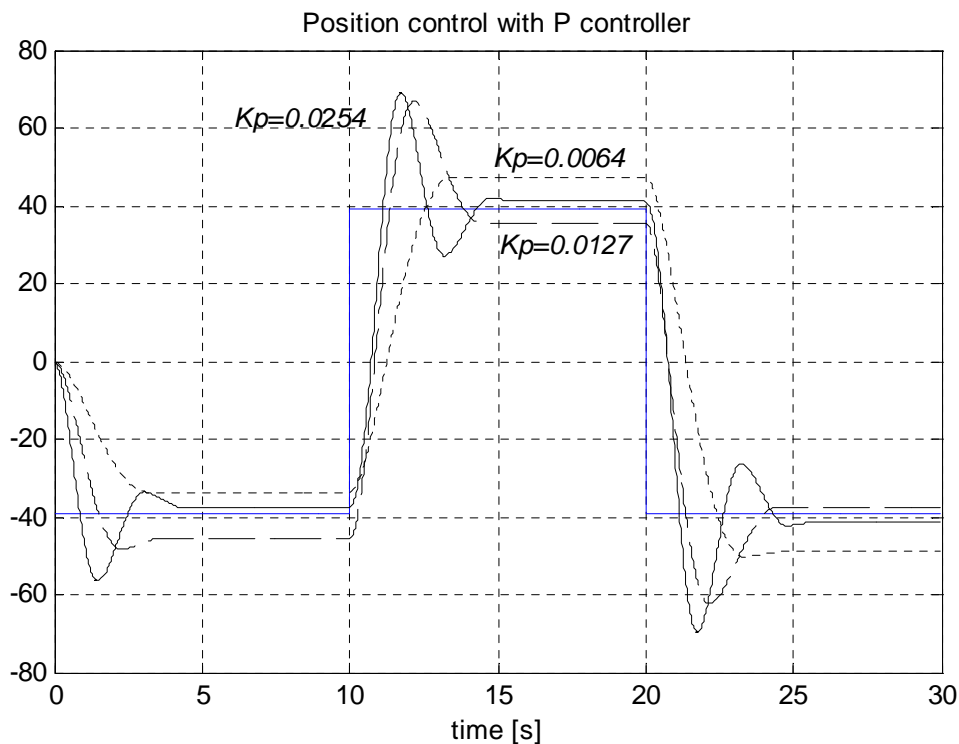

Fig. 7.3 Response of the closed-loop system with the P controller

The controls shown in Fig. 7.4 do not reach the zero value. It is due to the dead zone of the system which can be observed at the steady state characteristic shown in Fig. 6.8. The dead zone of the normalized u is in the range from -0.15 to 0.15.. Notice, that the control saturates for $K_p = 0.0254$.

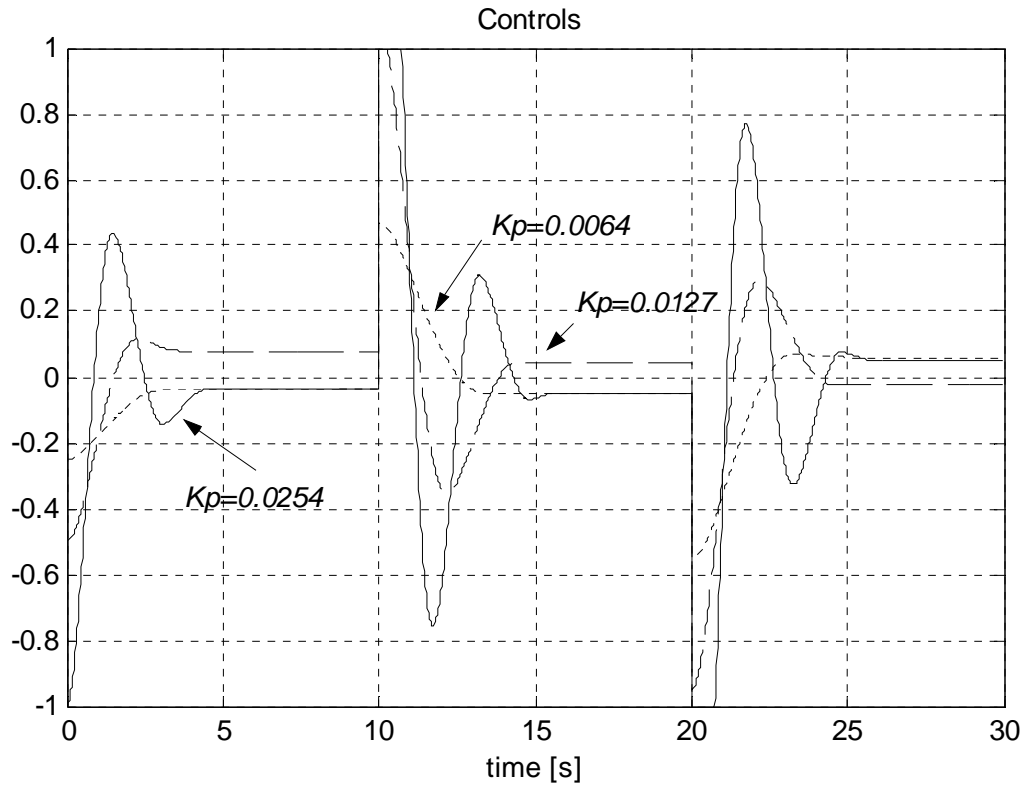

Fig. 7.4 Controls for different gains of the P controller

In the table below the steady state error is shown for the gain coefficients applied in these experiments. In accordance with theory if the K_p increases the steady state error decreases.

K	0.0064	0.0127	0.0254
ϵ_{∞}	20 %	9.1 %	4.8 %

PD controller

The main goal of the controller tuning is to obtain the standard second order system step response. The general form of the second order transfer function is

$$G_s(s) = \frac{\omega_n^2}{s^2 + 2\zeta\omega_n s + \omega_n^2}$$

If $0 < \zeta < 1$, then the step response of $G_s(s)$ exhibits an exponentially damped sinusoidal character with the following features:

- percentage overshoot $p_{\%} = 100e^{\frac{-\zeta\pi}{\sqrt{1-\zeta^2}}}$
- 2% settling time $t_s = \frac{4}{\zeta\omega_n}$
- time to peak $t_p = \frac{\pi}{\omega_n\sqrt{1-\zeta^2}}$

For given $p_{\%}$ and t_s one can calculate the damping coefficient ζ and natural frequency ω_n . Comparing a transfer function of the closed-loop system, which contains the coefficients of the controller, with the standard transfer function $G_s(s)$ one can calculate the controller coefficients.

EXAMPLE

Assume that we would like to design a PD controller for the position control of the servo system as it is shown in Fig. 7.5: Note that at the first glance the state feedback controller is used. But remember that $\omega = \frac{d\alpha}{dt}$. For this reason the applied controller is PD type.

The requirements corresponding to the dynamics of the closed-loop system are as follows:

- settling time $t_s \leq 2.5$ [s]
- and maximal overshoot $p_{\%} \leq 10$

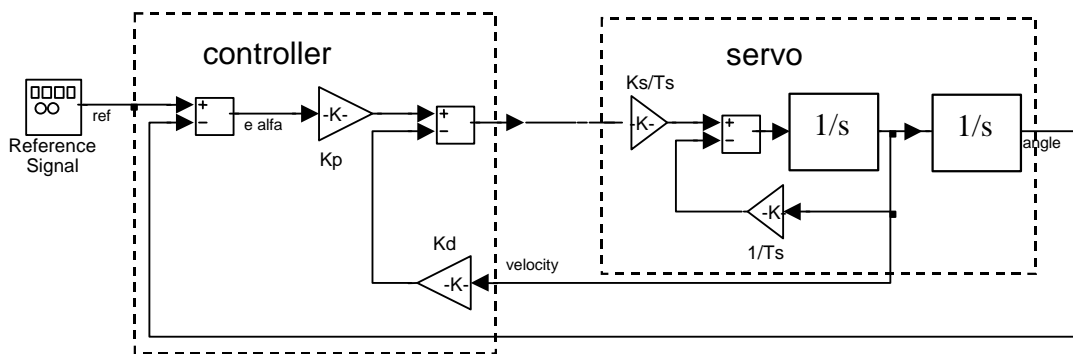

Fig. 7.5 Position control with the PD controller

The servo system has the transfer function $G(s) = \frac{K_s}{s(T_s s + 1)}$. The transfer function of the PD controller is $K(s) = K_p + K_D s$. The default values of the system coefficients are $K_s = 186$ [rad/s] and $T_s = 1.04$ [s].

Closing the control system we obtain the transfer function in the form

$$G_z(s) = \frac{\frac{K_p K_s}{T_s}}{s^2 + s \frac{K_s K_D + 1}{T_s} + \frac{K_p K_s}{T_s}}$$

Substituting values for the coefficients into the transfer function we obtain

$$G_z(s) = \frac{178.846 K_p}{s^2 + s(178.846 K_D + 0.9615) + 178.846 K_p}$$

The following relationships are obtained by comparing the transfer function with the standard transfer function of the second order system

$$178.846 K_p = \omega_n^2,$$

$$2\zeta\omega_n = 178.846 K_D + 0.9615.$$

Considering the formula and the condition for the settling time $t_s \leq 2.5[s]$ one obtains the inequality $K_D \geq 0.0125$.

Consequently, respecting the formula and the condition $p_{\%} \leq 10$ related to the assumed percentage overshoot one can calculate an unknown value as $\zeta = 0.5912$, later $\omega_n = 2.7039$ and $K_p = 0.0409$.

To check if the behaviour of the closed-loop system is consistent with requirements one can use the simulation method. Type at the Matlab prompt `K=[0.0409 0 0.0125]` to save the coefficients of the PD controller in the workspace. Click the *PID controller & linear model* button. The model depicted in Fig. 7.6 opens. Note, that the linear model of the servo is applied. The simulation results are shown in Fig. 7.7.

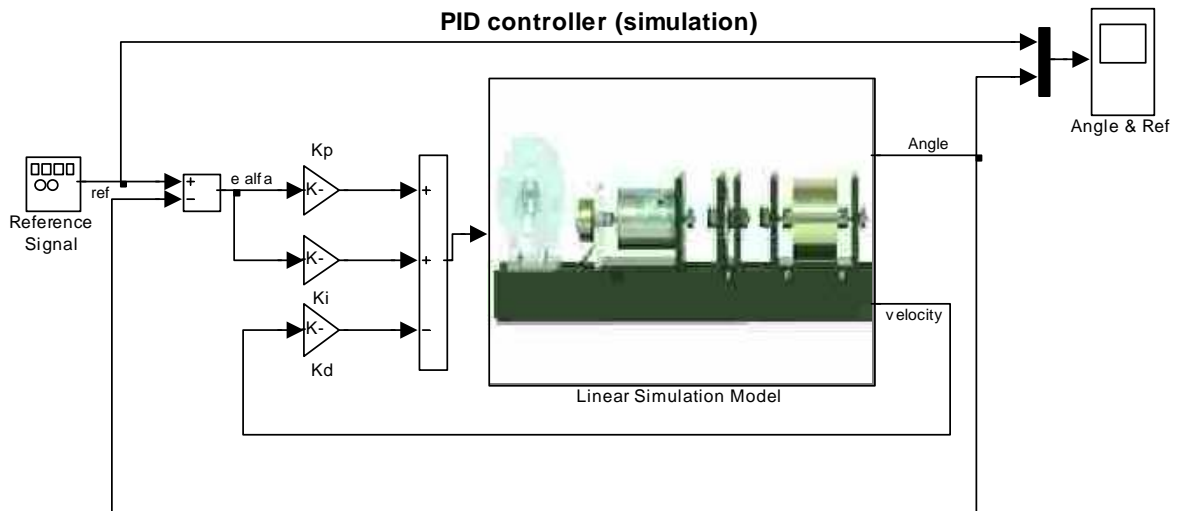

Fig. 7.6 Simulation model of the closed-loop system with the PD controller

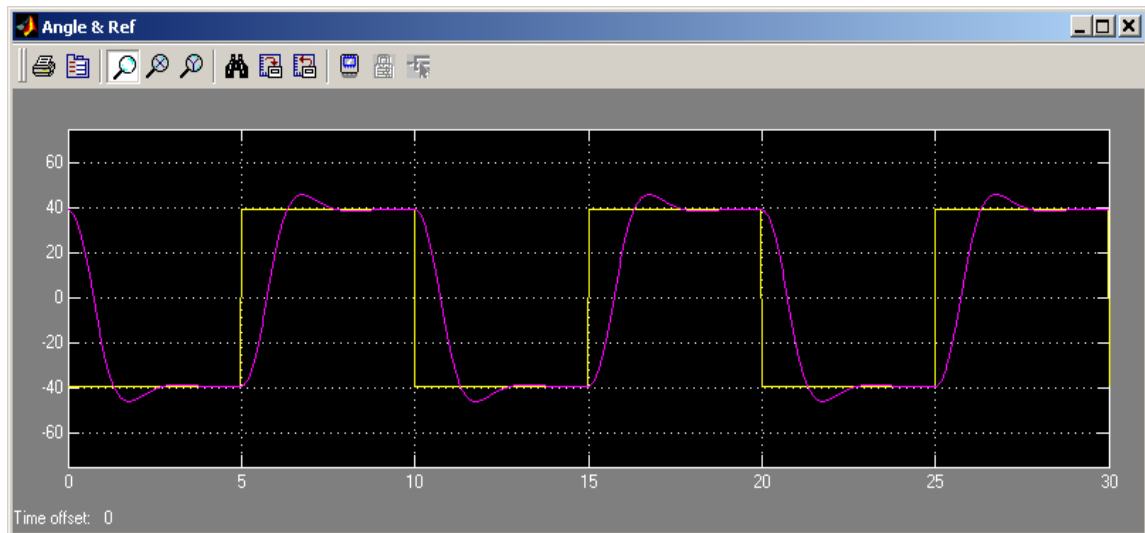

Fig. 7.7 Simulation results of the system with the PD controller

The percentage overshoot is too large, namely 16.4%. However the settling time is equal to 2.4[s] what is a satisfactory result. The steady state error is equal to 1.2% what shows that the goal of the control is satisfied but the requirement related to the percentage overshoot is missed.

Before redesigning a controller a real time experiment should be performed. Click the *PID control continuous* button. Click *PID controller* and the model presented in Fig. 7.1 opens. Build it and start the real-time code. The results are presented in Fig. 7.8. Notice, that the response of the real system always differs slightly from the simulated one.

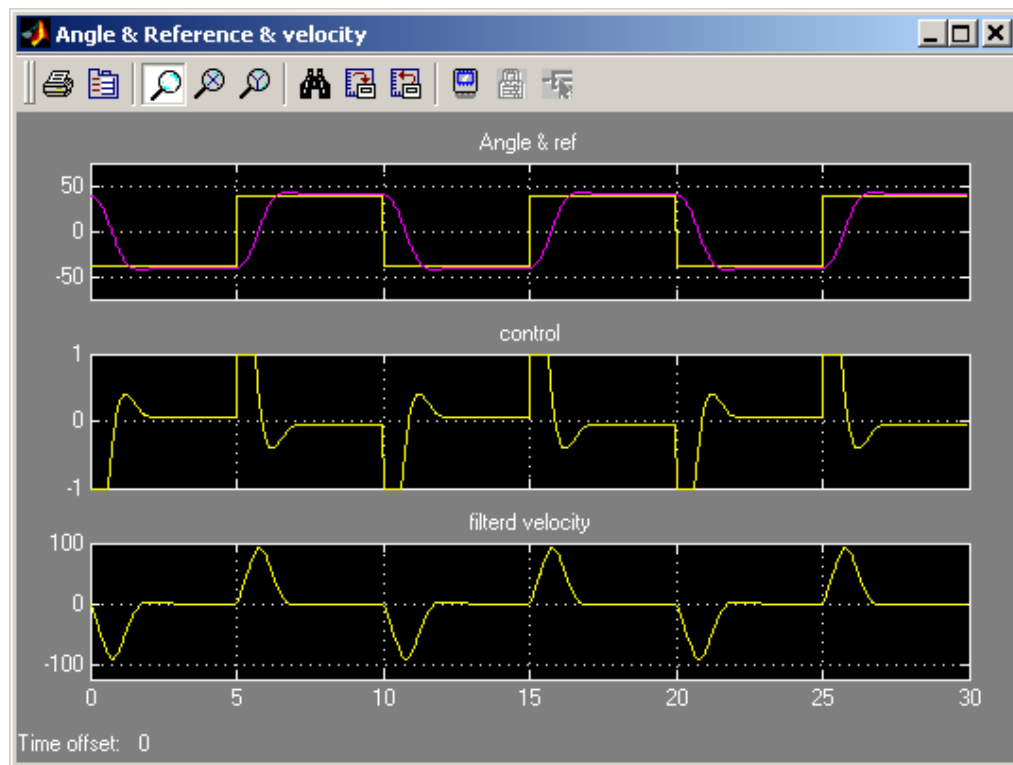

Fig. 7.8 Results of the real-time experiment with the PD controller

To see in details differences between the real time and simulation responses of the closed-loop system execute the *servo_plot_pid.m* file. This file is included in the *Servo Toolbox* but is accessible only from Matlab Command Window. The plot is depicted in Fig. 7.9. The table below includes the details read from the figure.

	Simulation	Real-time experiment
t_s [s]	2.4	3
$p\%$ [%]	16.5	8.14
Steady state error [%]	0.2	4.02

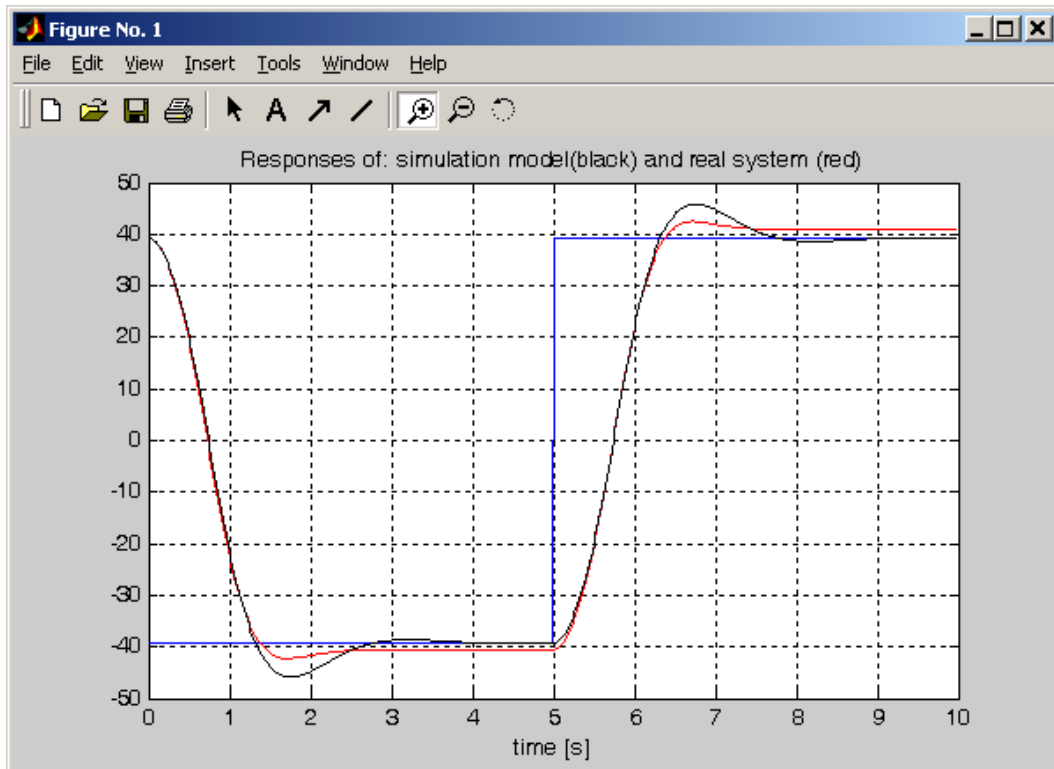

Fig. 7.9 Comparison of the real-time and simulation experiments with the PD controller

The overshoot of the real-time experiment is small but the steady state error is too large and the settling time is too long.

We are trying to increase proportional coefficient K_p of the PD controller. It will increase the overshoot (that is an admissible step) and decrease the steady state error (to a value which is required) and shorten the settling time what is required also.

Type at Matlab prompt: $K=[0.0609 \ 0 \ 0.0125]$ and repeat the real-time experiment with the PD controller and observe the results in the scope of the model. To see all details of responses vs. time type the following commands:

```
a=1;b1=length(PD_C.time);
t=PD_C.time(a:b);
a=1;
b=10/(t(2)-t(1)); %plot only first 10 seconds of response
t=t(a:b);
plot(t,PD_C.signals(1).values(a:b,1),'b',t,PD_C.signals(1).values(a:b,2),'k');grid;
```

```

title('Responses of: real system with corrected PD controller');
xlabel('time [s]');

```

The plot which is obtained is shown in Fig. 7.10 The values of the percentage overshoot, settling time and steady state error are as follows:

$$p_{\%} = 12.5 [\%], \quad t_s = 2.23 [s] \text{ and } \epsilon_{\infty} = 0.33 [\%].$$

The overshoot is a little greater than the assumed one but the settling time is fine and the steady-state error is perfect. We can conclude that the goal of the control is satisfied and that the PD controller just designed works well.

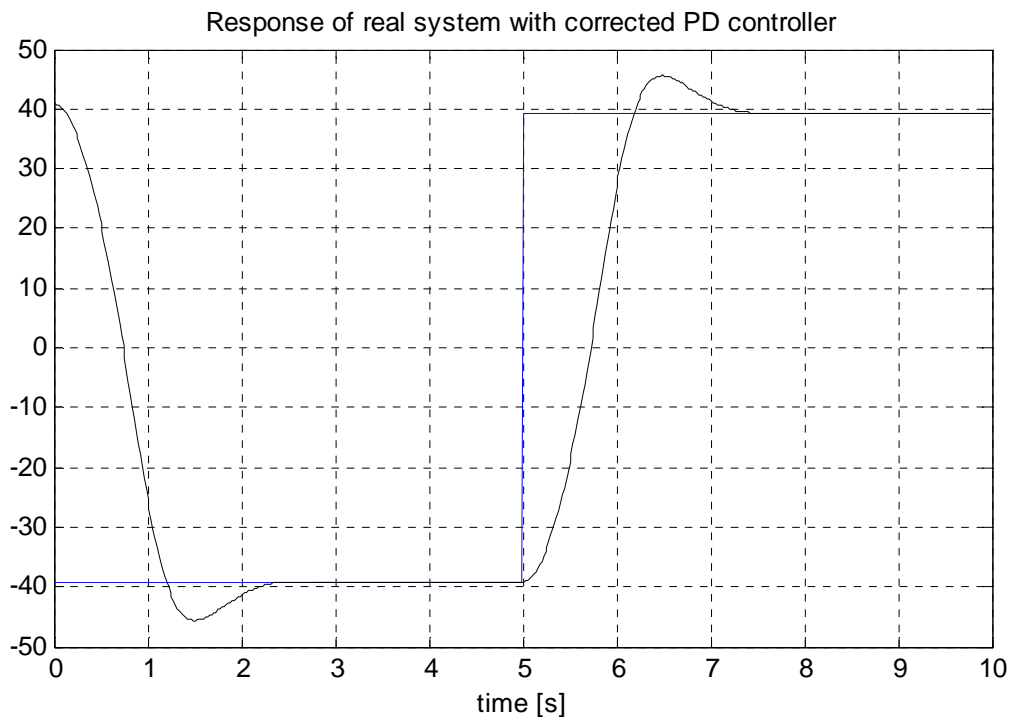

Fig. 7.10 Response of the real-system with the corrected PD controller

Position control with the backlash module

In this section position control problem is considered when the backlash exists in the servo system as it is shown in Fig. 7.11.

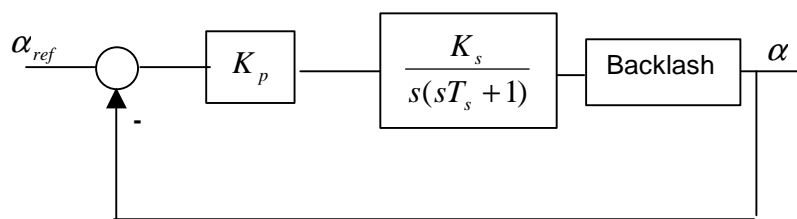

Fig. 7.11 Position servo control with the backlash and P controller

The backlash is present in a number of mechanical and hydraulic systems. In many cases backlash is necessary to proper work of a mechanical system. A gearbox without backlash will not work if temperature rises. The backlash in a system decreases control performance and in most applications introduces oscillations to the controlled system.

At the beginning the backlash have to be added to existing servo system. Add this module between the inertia and the encoder modules in the system chain. It is important that encoder measures an angle after the backlash module.

To test a behaviour of the real-time system with the backlash module for different gains of the P controller click *PID control continuous* button in *Servo Control Window*. The model given in Fig. 7.1 opens.

Type $K=[0.1024\ 0\ 0]$ at the MATLAB prompt. It sets the proportional coefficient K_p of the P controller. Assuming a desired range of the change of the output disk equal to $\pi/2$ set the reference input signal equal to $25*\pi/2$ (it is the measured angle at the input to the gearbox). Also set the frequency of the reference input to 0.05 Hz and sample time to 0.002 [s].

- Build the model.
- Click the *Simulation/Connect to target* and *Start real-time code* options to start the experiment.

The results are given in Fig. 7.12 and Fig. 7.13.

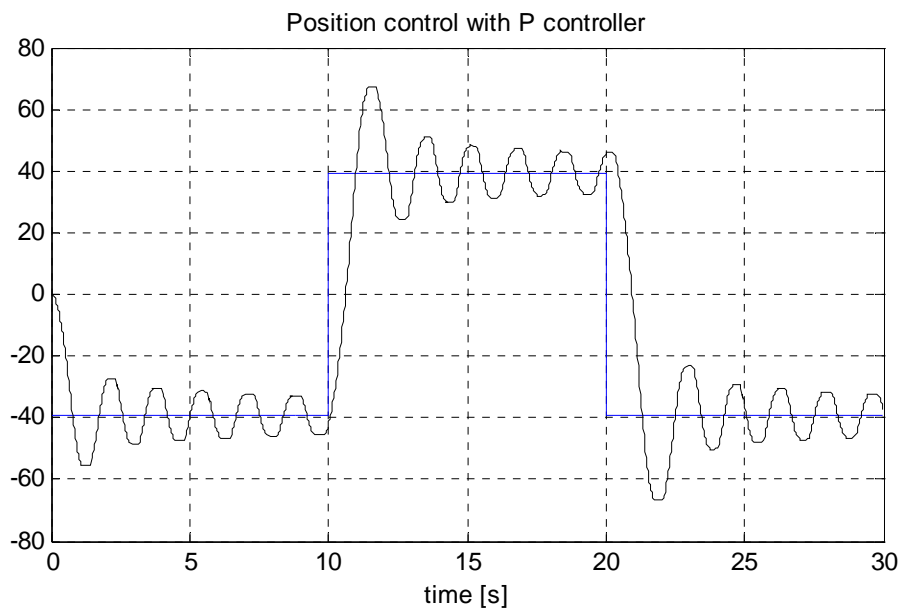

Fig. 7.12 Position control with the backlash module - $K_p = 0.1024$

Notice, that there are oscillations in the system. The oscillations are far from the harmonic shape. They are generated as the result of a limit cycle in the system. The control shown in Fig. 7.13 is saturated. It is the well known fact that decreasing the proportional gain of the controller can correct this unfavourable behaviour of the servo system.

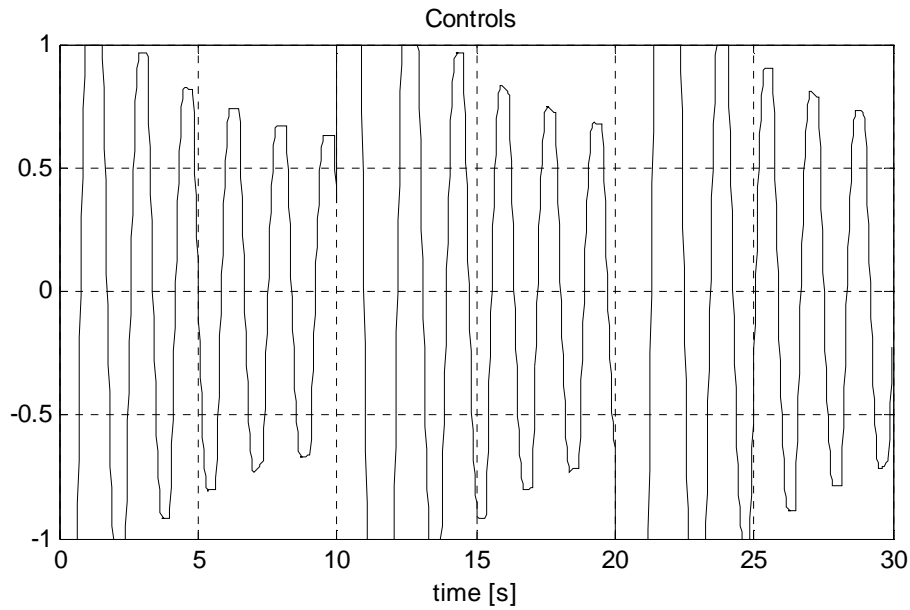

Fig. 7.13 Control signal

Repeat the experiment for $K_p = 0.0128$. The results are shown in Fig. 7.14 and Fig. 7.15.

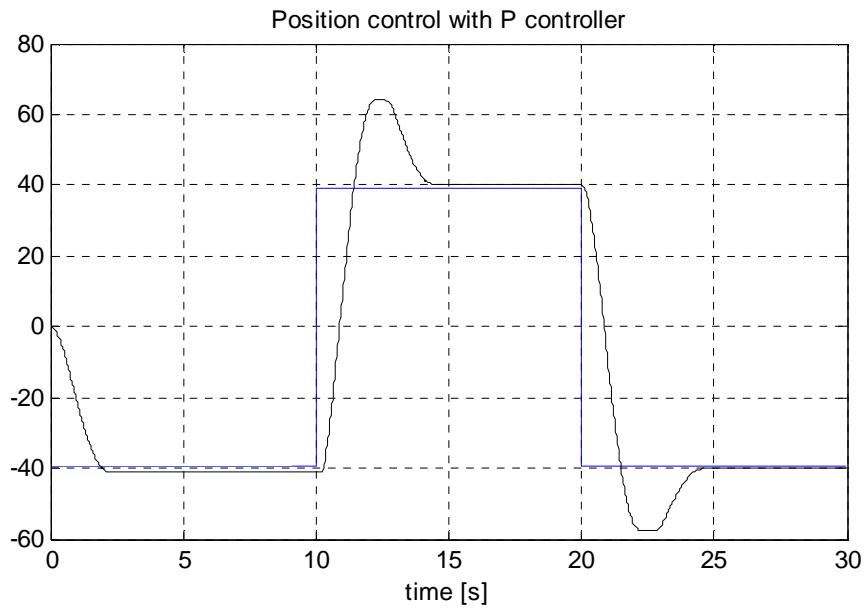

Fig. 7.14 Position control with backlash module $K_p = 0.0128$

Notice, that oscillations are not present in this case. The desired position is reached with 2.8% accuracy. The control does not saturate. We conclude that the closed-loop system behaviour is satisfactory.

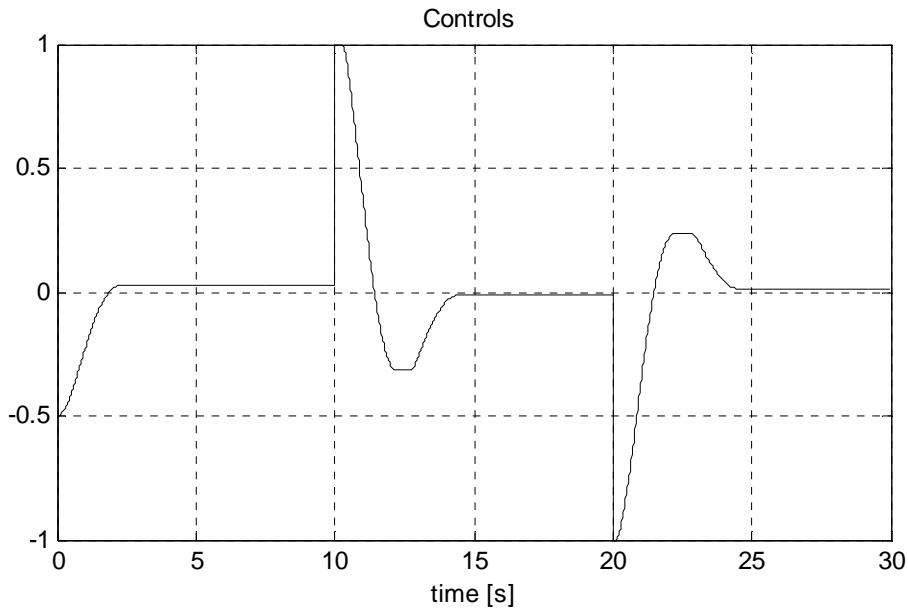

Fig. 7.15 Control signal

7.2. PID Velocity control

The task of the velocity control is to keep the desired velocity in the presence of disturbances. The disturbances can be introduced as a change of the velocity reference signal or as a change of the motor load. To disturb the reference velocity the potentiometer can be used. The load disturbances can be introduced by braking slightly the inertia load of the system. In the example the load disturbances are introduced manually.

Click the *Velocity control* button in *Servo Control Window* and model shown in Fig. 7.16 opens.

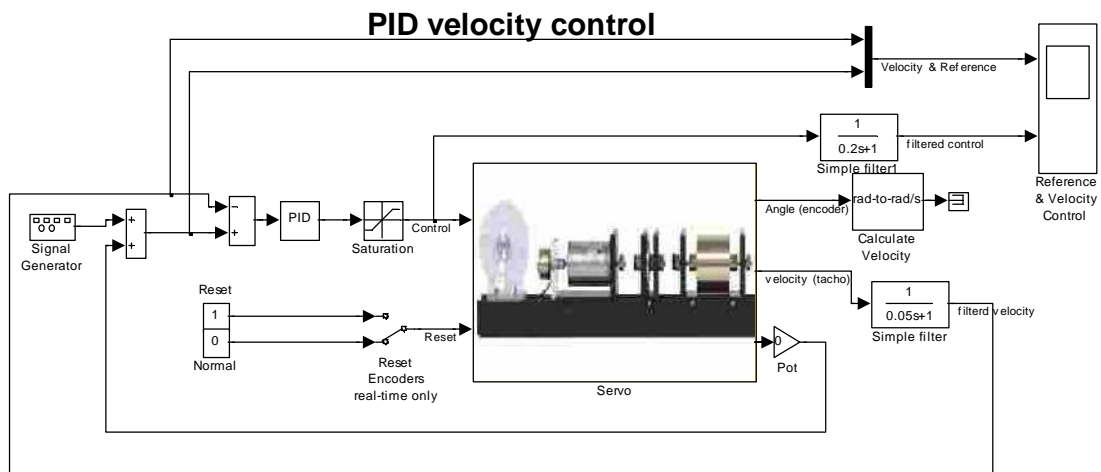

Fig. 7.16 PID velocity control in the real-time system

Set the *sine* reference velocity, amplitude equal to 40 [rad/s] and frequency equal to 0.1 [Hz] . Simulation time set equal to 30 [s]. The *Gain* of the potentiometer set equal to zero. The coefficients of the PID controller set to the following values: $K_p = 0.15$ and $K_i = 0.03$.

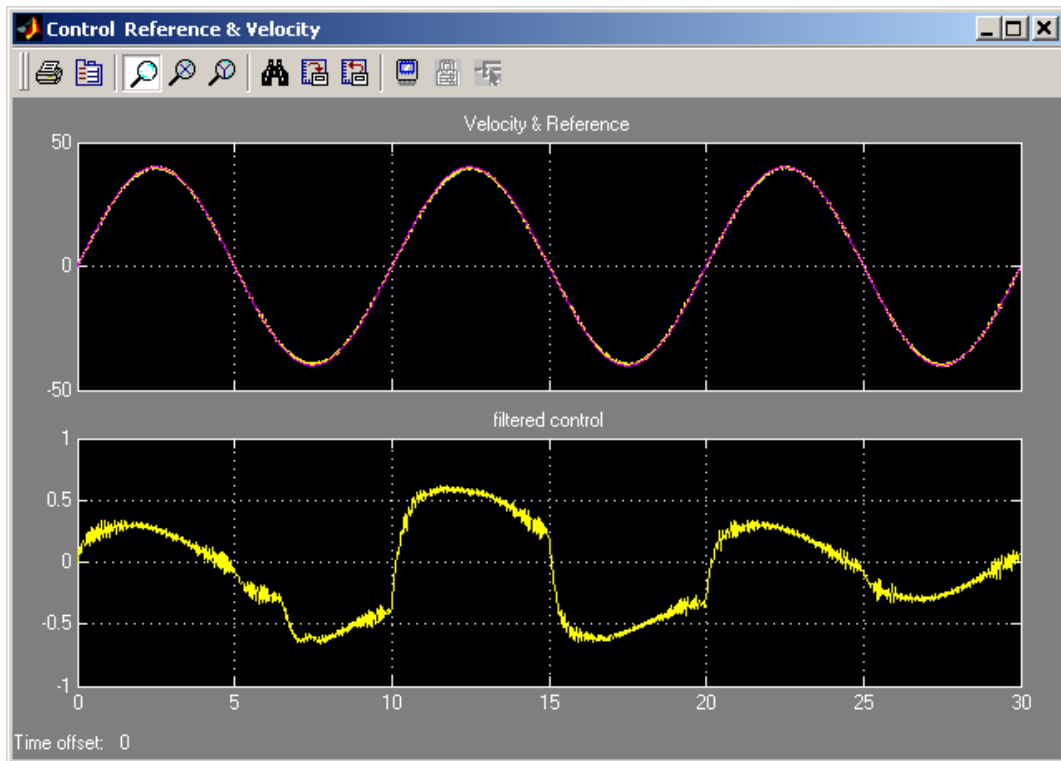

Fig. 7.17 The results of the PID velocity control

Build the model and run the real time code. The results of the experiment are given in Fig. 7.17.

One can see that the disturbances of the motor load are introduced manually after five seconds from the start and remain active in the period of 15 seconds. Note, that the control increases in this time interval. The results are stored in the *VelCtrl* variable stored in the Matlab workspace.

Type at the Matlab prompt :

```
plot(VelCtrl.time, VelCtrl.signals(1).values(:,2), 'r', VelCtrl.time, VelCtrl
.signals(1).values(:,1), 'k'); grid; xlabel('time [s]'); title('Reference
velocity (red) - measured velocity (black)');
```

The plot is shown in Fig. 7.18 . In this scale the differences between the diagrams are invisible. The details of the reference velocity and the measured velocity are shown in Fig. 7.19.

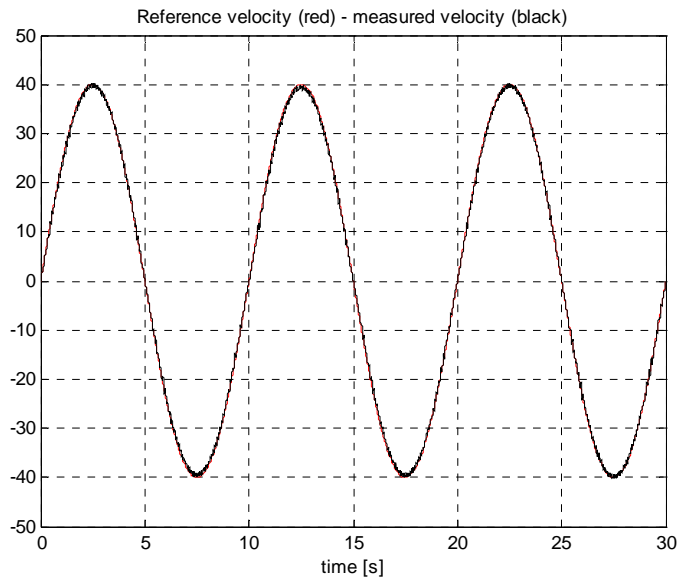

Fig. 7.18 Reference and measured velocity

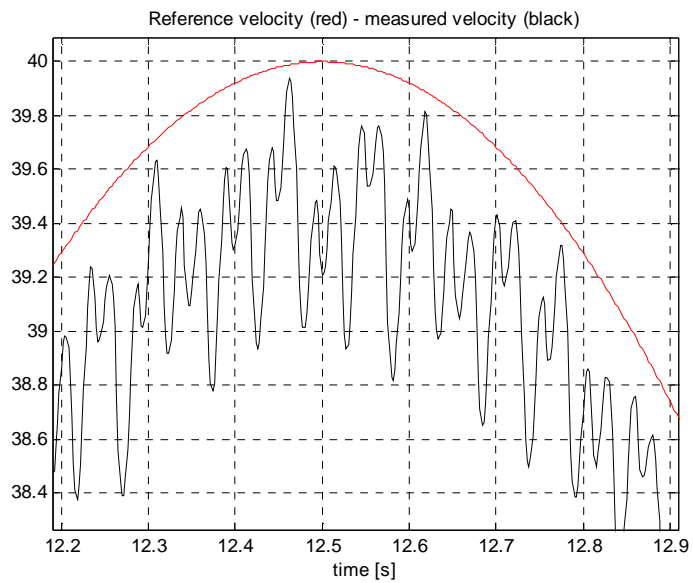

Fig. 7.19 Zoomed data

The tracking error of the velocity (at 12.5 seconds) is equal to 1%. Of course this error varies in time but it is rather small as far as the error of the velocity measurements is concerned.

7.3. Multivariable control design

The section demonstrates how properties of a closed-loop system are influenced by the design parameters: the closed-loop roots and sampling period. Two methods of the closed-loop systems design are shown. The first is based on the pole placement and is applied for continuous systems. The second control method, known as "deadbeat control" is used for discrete systems.

7.3.1. Pole-placement method

A closed-loop system with feedback gains from the states is analysed. The approach we wish to apply is the pole placement. It means that we can change the closed-loop system roots. There are different ways of achieving this. One of the design methods is described below.

The continuous-time system is represented by the state equation:

$$\begin{aligned}\dot{x} &= Ax + Bu \\ y &= Cx\end{aligned}$$

The state controller realises a linear feedback control law in the form: $u = K(y_d - y)$, where K is the feedback gain matrix and y_d is the desired output vector.

We request that the roots of the closed system are equal to λ_1, λ_2 (fixed). The design methods consist in finding K that the roots of the closed-loop system are in the desired locations. That means, we assume dynamic properties of the closed system. It can be shown that there exists a linear feedback that gives a closed-loop system with roots specified if and only if the pair (A, B) is controllable. It is clear that closed-loop system has to be stable and it is a 'sine qua non' assumption of the design.

The state matrix of the closed-loop system is

$$A_c = (A - BKC).$$

For the case of the DC motor the matrix A_c is given as

$$A_c = \begin{bmatrix} 0 & 1 \\ -\frac{K_s k_1}{T_s} & -\frac{1 + K_s k_2}{T_s} \end{bmatrix},$$

and the characteristics equation has the form

$$\lambda^2 + \lambda \frac{1 + K_s k_2}{T_s} + \frac{K_s k_1}{T_s} = 0.$$

By means of the feedback gains, the location of roots of the characteristics equation may be changed. From the Vieta's formula we obtain

$$\lambda_1 \cdot \lambda_2 = \frac{K_s k_1}{T_s} \quad (\lambda_1 + \lambda_2) = -\frac{1 + K_s k_2}{T_s},$$

and we can calculate k_1 and k_2 from

$$k_1 = \frac{\lambda_1 \cdot \lambda_2 \cdot T_s}{K_s} \quad k_2 = -\frac{(\lambda_1 + \lambda_2)T_s + 1}{K_s} . \quad (7.1)$$

It is clear that we can require the desired behaviour of the closed-loop system but we have to keep the control between appropriate limits $|u(t)| \leq 1$. When the control variable saturates, it is necessary to be sure that the system behaves properly.

EXAMPLE

Assume that we would like to design a closed-loop system without oscillations. A possible selection of the roots is:

$$\lambda_1 = -2 \text{ and } \lambda_2 = -3 .$$

For the identified parameters (an example) $K_s = 186$ [rad/s] and $T_s = 1.04$ [s] we can calculate k_1, k_2 from formula (7.1)

$$k_1 = 0.0335 \quad \text{and} \quad k_2 = 0.0226$$

Then, we simulate the closed-loop system with the feedback gains k_1, k_2 .

Perform the following steps:

- type `K=[0.0335 0.0226]` and `servo` at the MATLAB prompt.
- Double click the *State feedback control continuous* and *State feedback controller* buttons. The model shown in Fig. 7.20 opens. Assuming a desired range of the change of the output disk position equal to $\pi/2$ set the reference input signal equal to $25 \cdot \pi/2$ (it is the measured angle at the input to the gearbox). Also set the frequency of the reference input equal to 0.1 Hz and sample time equal to 0.002 s.
- Build the model.
- Click the *Simulation/Connect to target* and *Start real-time code* options to start the experiment.

The results are presented in Fig. 7.21. Notice, that the response of the system is slow and not accurate. The reference angle is reached with accuracy equal to 6% and the settling time is about 4[s].

We can change the roots of the closed-loop system to make the system faster. Assuming $\lambda_1 = -4$ and $\lambda_2 = -5$ we obtain: $k_1 = 0.1118$ and $k_2 = 0.0449$.

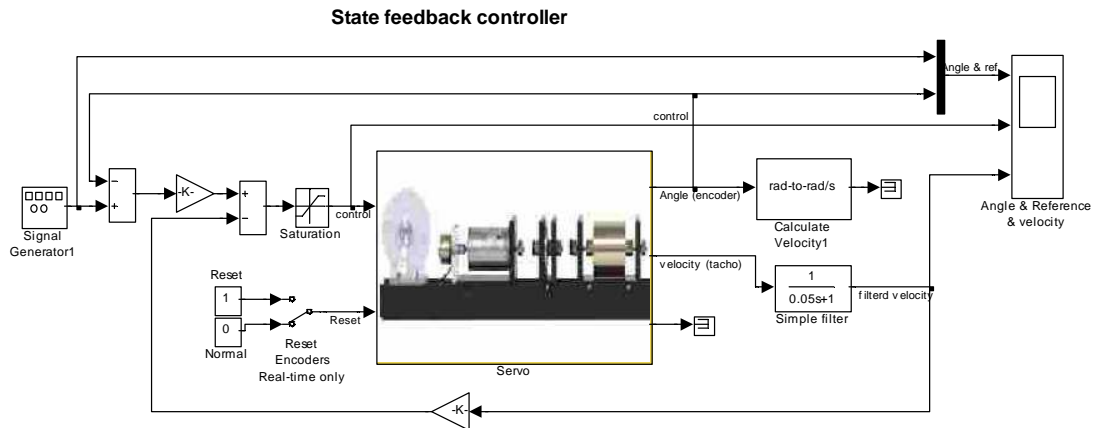

Fig. 7.20 Real-time model with state feedback controller

Type at the Matlab prompt $K=[0.0335 \ 0.0226]$ and repeat the experiment with the new values of k_1 and k_2 . The experimental results are shown in Fig. 7.22. Notice, that the response of the system is faster and more accurate. The reference angle is reached with accuracy equal to 2.3% and the settling time is 2.5 [s]. These results outperform the previous one.

In both experiments the control saturates despite that the goals of the design are achieved.

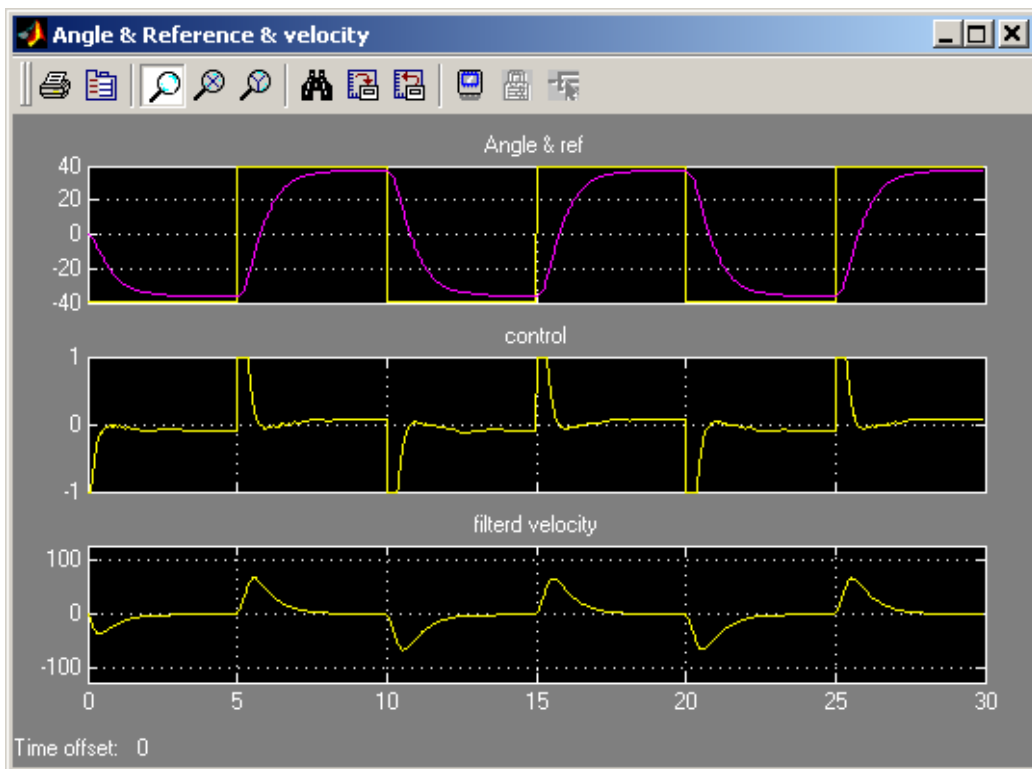

Fig. 7.21 Experiment of the closed-loop system , $\lambda_1 = -2$ and $\lambda_2 = -3$

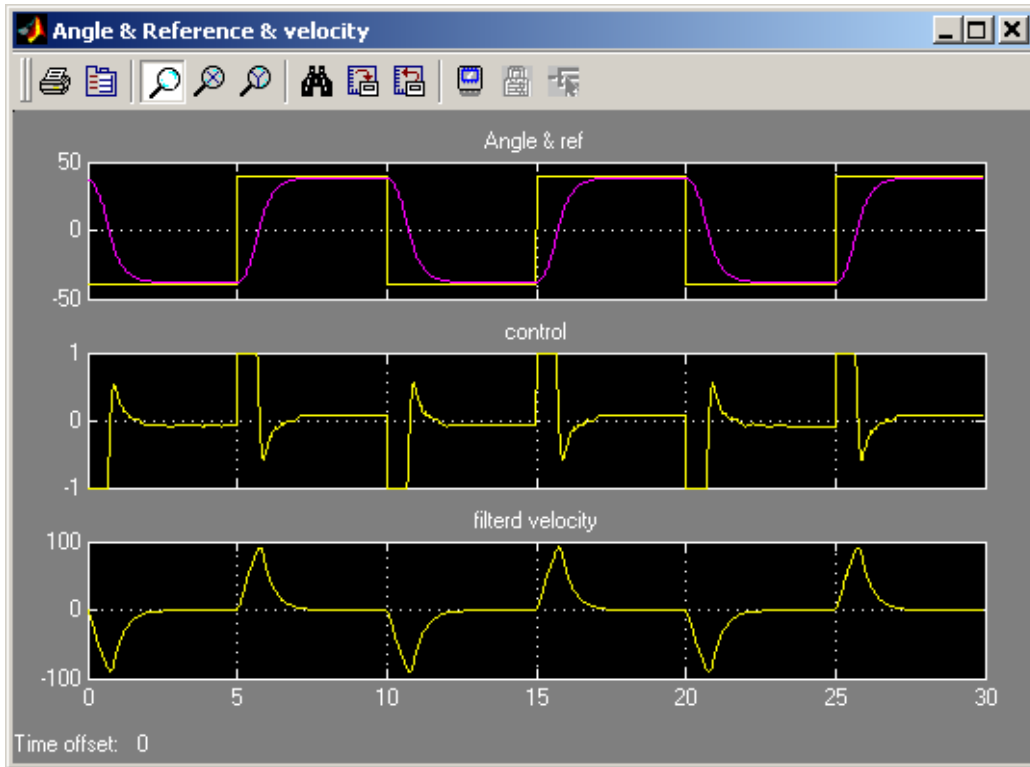

Fig. 7.22 Experiment of the closed-loop system , $\lambda_1 = -4$ and $\lambda_2 = -5$

7.3.2. Deadbeat controller

It is the control method unique to discrete systems in which we calculate feedback gains in such a way that the roots of the closed system are equal to zero. This control strategy has the property that it drives the states of a closed-loop system from arbitrary values to zero in at most N steps ($\dim(A)=N$). It is the fastest possible discrete controller.

The sampling time T_0 is the only design parameter. The magnitude of the control variable u can be decreased by increasing the sampling time T_0 , or vice versa. For a given range of the reference variable step a suitable sample time can be determined. The main problem of the design is the saturation of the system actuators.

The discrete system is described by a discrete state equation:

$$x[(n+1)T_0] = A_D x[nT_0] + B_D u[nT_0]$$

$$y[nT_0] = C_D x[nT_0].$$

The matrices A_D and B_D are calculated from the continuous state-space model using the following, well known, relations:

$$A_D = e^{AT_0} \quad B_D = \left[\int_0^{T_0} e^{At} dt \right] B \quad C_D = C = I.$$

For a discrete model of the DC motor matrices A_d and B_d have the form

$$A_D = e^{AT_0} = \begin{bmatrix} 1 & T_s(1 - e^{-\frac{T_0}{T_s}}) \\ 0 & e^{-\frac{T_0}{T_s}} \end{bmatrix}, \quad B_D = \begin{bmatrix} K_s(T_0 - T_s(1 - e^{-\frac{T_0}{T_s}})) \\ K_s(1 - e^{-\frac{T_0}{T_s}}) \end{bmatrix}.$$

If we assume reachability of the pair (A_D, B_D) and a control law in the form

$$u[nT_0] = K(y_d[nT_0] - y[nT_0])$$

$$K = [k_1 k_2],$$

we obtain the closed-loop system shown in Fig. 7.23.

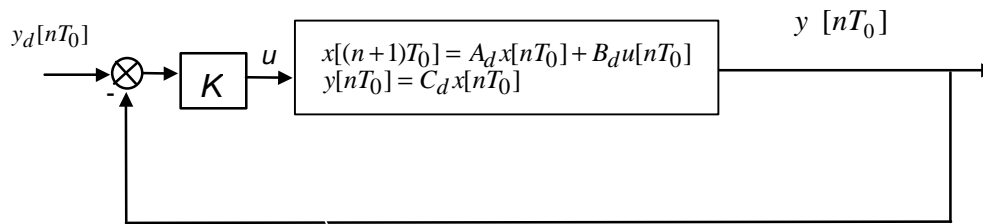

Fig. 7.23. Closed-loop system with the feedback gain

The closed-loop system is described by the equation

$$x[(n+1)T_0] = (A_D - B_D K C_D)x[nT_0] + B_D K y_d[nT_0].$$

Feedback gains for the deadbeat controller are calculated from the equation:

$$\det(\lambda I - (A_D - B_D K C_D))|_{\lambda_i=0, i=1,2} = 0.$$

Design method

We can design the deadbeat controller using a simulation method. The following steps are necessary in this case:

1. choose the sampling time T_0 ,
2. create the discrete model,
3. calculate feedback gains,
4. simulate the closed-loop discrete system,
5. if the control overruns saturation limits increase the sampling time T_0 and repeat the steps from 1 to 5.

EXAMPLE

This example shows how to design the deadbeat controller.

A goal of the control is to track a reference signal (the angle of the motor shaft). The reference signal is assumed to be a square wave.

Type *servo* at the MATLAB prompt and then double click the *State feedback control discrete* button. To design the controller click the *Calculate deadbeat controller* button. It executes the *servo_calc_db.m* file where a coefficients of deadbeat controller are calculated according to the algorithm shown above. The body of this file is listed below. Note the comments in the file.

```
% Continuous linear model of the servo system.
% Parameters of the servo are read from workspace

A=[0 1;0 -1/Ts]; B=[0; Ks/Ts]; C = [1 0;0 1]; D = zeros( 2, 1 );

% If the distance to the reference signal is big control value in the
% first sample time is big too. Due to we are looking for such a T0
% when control does not saturate,we must assume the maximum change of
% the reference signal.

delta_ref=[25*pi;0]; %% it is maximal change of the reference signal

% we start look for T0
T0=0.1;
for i = 1:200
T0=T0+0.005;
% ** Discrete model for sampling time T0*

[Ad,Bd]=c2d(A,B, T0);

% Now we calculate a coefficients of deadbeat controller
% using the formula : eig(Ad-Bd*K)=0

Z=[Bd(1) Bd(2); Ad(2,2)*Bd(1)-Ad(1,2)*Bd(2) Ad(1,1)*Bd(2)];
X=[Ad(1,1)+Ad(2,2);Ad(1,1)*Ad(2,2)];
K=(Z\X)';

% Now coefficients of the controller are saved in K

% checking if the control saturates in the first sample time:
% u(1)=K*delta_ref;

if abs(K*delta_ref)<=1
    K
    T0 %% write K and T0 in Matlab command window
    return
end
end
```

The variables K and T_0 are stored in the MATLAB workspace after the execution of the above m-file. In our case for $K_s = 186$ [rad/s] and $T_s = 1.04$ [s] we obtain $K = [0.0127 \ 0.0091]$ and $T_0 = 0.7950$.

Now double click the *State feedback controller* buttons to perform the real-time experiment and the model depicted in Fig. 7.24 opens.

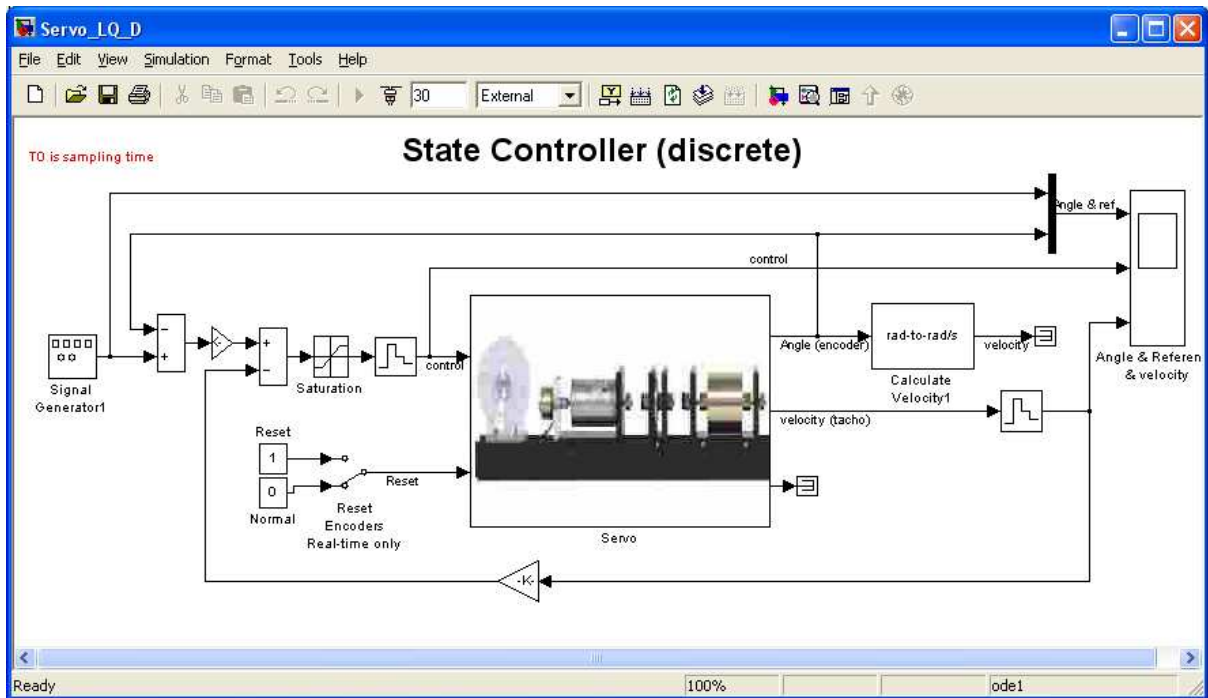

Fig. 7.24 State feedback controller – a discrete model

This model differs in details from the other models. Due to the fact that the model is discrete, and the sampling time T_0 can vary from experiment to experiment T_0 is read from the Matlab workspace. Variable T_0 is located in the Simulink model in the following places: in *Fixed step size* in tag *Solver* which is located in *Simulation/Simulation Parameters* option, in all *Zero-Order Hold* blocks and in the mask of the *Servo* device driver. There is no filter connected to the output of the tachogenerator. The filter applied in other models is not discrete one and can not be used here. However it is interesting how the controller works without filtering of the velocity signal.

Set the amplitude of the input signal to $25 \cdot \pi / 2$ (as in the previous example), the frequency of the reference signal to 0.05 Hz. Set simulation time equal to 60 [s] and time range in the scope also equal to 60 [s].

Due to the fact that the model includes variables K and T_0 and some settings are changed rebuild it. Click *Simulation/Connect to target*. Click the *Start real-time code* option to start the experiment. The results are shown in Fig. 7.25.

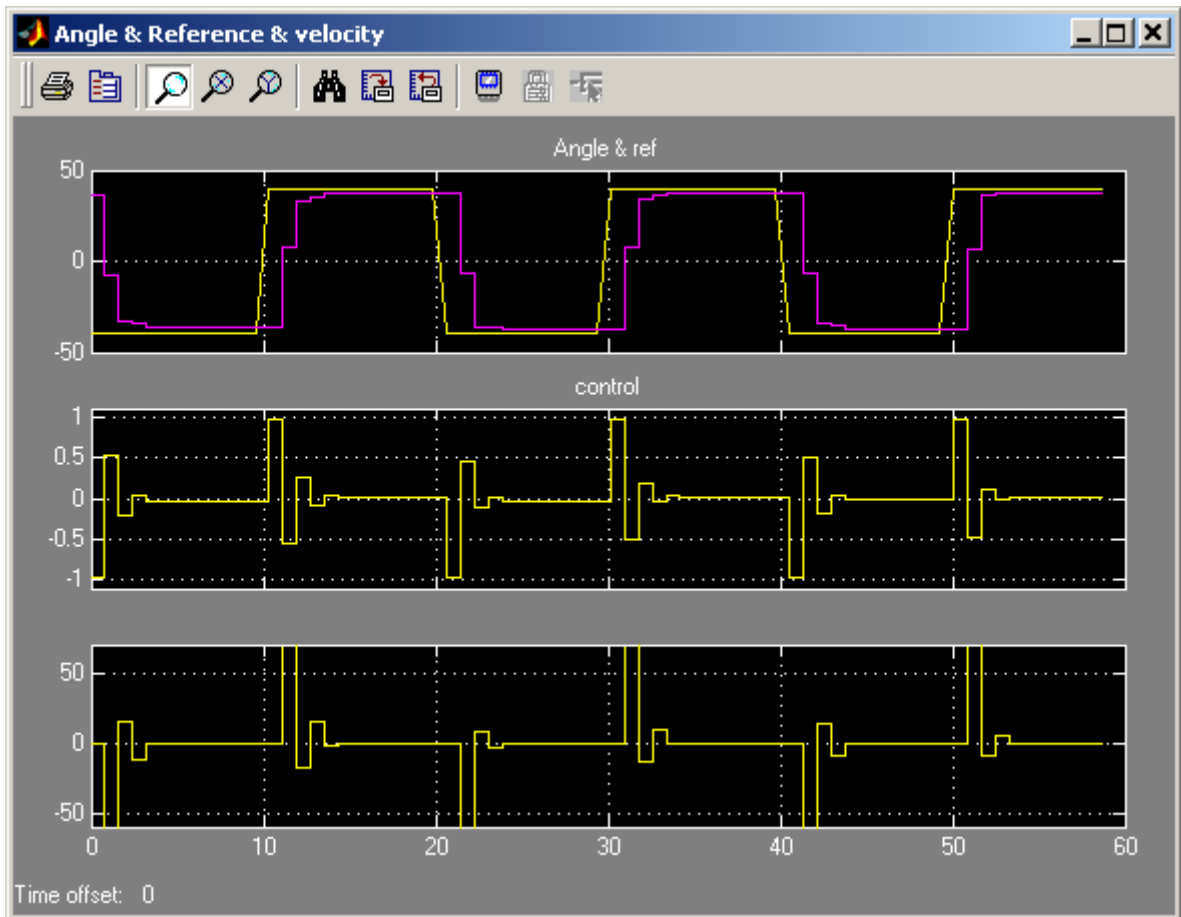

Fig. 7.25 Results of the position control using the deadbeat controller

Note, that the system does not reach the reference angle in two steps. In fact, the servo is a nonlinear system and it is only approximated by a linear model. Notice, that this control is significant only during two first sampling intervals.

7.4. Optimal design method: LQ controller

The linear-quadratic problem (LQ problem) is a central one in the theory and applications of optimal control. There are two versions of the LQ problem: the open-loop and the closed-loop optimal control problems. Either the optimal control is given as an explicit function of time for fixed initial conditions, or the optimal controller is synthesised. Further only the second case is considered. The main result of the finite-dimensional linear-quadratic theory is that under suitable assumptions the optimal feedback controller is linear with respect to the state, and constant with respect to time.

The synthesis of the discrete and continuous LQ controller is presented below. For a very small value of the sampling time the response of the discrete system converges to the response of the corresponding continuous system. The most important question for a designer of a control system, as far as LQ control problem is concerned, is how to select the weighting factors in the cost function.

Let us examine separately the continuous and discrete LQ problems.

7.4.1. The continuous case

The dynamical model of the DC-motor is described by the linear differential equations:

$$\begin{aligned}\dot{x} &= Ax + Bu \\ y &= Cx\end{aligned},$$

where the matrices A , B and C have the form

$$A = \begin{bmatrix} 0 & 1 \\ 0 & -\frac{1}{T_s} \end{bmatrix}, \quad B = \begin{bmatrix} 0 \\ \frac{K_s}{T_s} \end{bmatrix}, \quad C = \begin{bmatrix} 1 & 0 \\ 0 & 1 \end{bmatrix}. \quad (7.2)$$

The desired input time history of the state vector is given by $y_d(t) = [y_{1d}(t), y_{2d}(t)]$. Hence, the error vector e is defined

$$e(t) = y_d(t) - y(t).$$

A typical quadratic cost function (performance index) has the form

$$J(u) = \frac{1}{2} \int_0^{T_k} [e^T(t)Qe(t) + u^T(t)Ru(t)]dt,$$

where:

- matrix $Q \geq 0$, Q is a nonnegative definite matrix,
- matrix $R > 0$, R is a positive definite matrix,
- the (A,B) pair is controllable.

The weighting matrices Q and R are selected by a designer but they must satisfy the above conditions. It is most easily accomplished by picking the matrix Q to be diagonal with all diagonal elements positive or zero. Some positive weight ($|R/\neq 0$) must be selected for the control, otherwise the solution will include infinite control gains.

The values of elements of Q and R matrices weakly correspond to the performance specification. A certain amount of trial and error is required with a simulation program to achieve a satisfactory result. A few guidelines can be recommended. For example, if all states are to be kept under close regulation and Q are diagonal with entries so selected that a fixed percentage change of each variable makes an equal contribution to the cost. The matrix R is also diagonal.

If the maximum deviations of the servomechanism outputs are: $y_{1\max}$, $y_{2\max}$, and the maximum deviation of control is u_{\max} , then the cost is:

$$Q(1,1)y_1^2 + Q(2,2)y_2^2 + Ru^2$$

The coefficients of the Q and R matrices can be set related to the rule:

$$Q(1,1) = \frac{1}{(y_{1\max})^2}, \quad Q(2,2) = \frac{1}{(y_{2\max})^2} \quad \text{and} \quad R = \frac{1}{(u_{\max})^2}$$

This rule can be modified to satisfy desired root locations and transient response for selected values of weights. One must avoid saturation effects both of outputs and control.

Due to the differences in methods of analysis, problem formulation and the form of results, we strongly distinguish the linear-quadratic problem with a finite settling time from that with a infinite settling time. However in applications we frequently encounter the situation when the termination moment of the control process is so far away that it does not affect the current control actions. The infinite-time optimal control problem is then posed. The cost function is replaced by the formula:

$$J(u) = \int_0^{\infty} [e^T(t)Qe(t) + u^T(t)Ru(t)]dt \quad (7.3)$$

Then the optimal scalar control u^* and the optimal trajectory vector y^* are given

$$u^* = K(y_d - y^*) \quad (7.4)$$

where K is the feedback matrix.

The optimal control problem is now defined as follows: find the gain K such that the feedback law (7.4) minimises the cost function (7.3) subject to the state equation (7.2). The calculation of the control variable which minimizes the criterion (7.3) is a dynamic optimisation problem. This problem can be solved by variation calculus applying the maximum principle due to the Bellman optimisation principle. The procedure returns the optimal feedback matrix K , the matrix S , the unique positive definite solution to the associated matrix Riccati equation:

$$SA + A^T S - SBR^{-1}B^T S + Q = 0$$

Due to the quadratic appearance of S , there is more than one solution, and S must be positive definite to select the correct one. The procedure returns also the matrix E , the closed-loop roots:

$$E = \text{eig}(A - B^*K^*C)$$

The vector K can be calculated by a numeric iterative formula on the basis of the Riccati equation. The associated closed-loop system $\dot{e} = (A - BKC)e$ is asymptotically stable.

To solve the LQ controller problem the *lqry* function from the *Control System Toolbox* can be used. The synopsis of *lqry* is: $[K,S,E] = \text{lqry}(A,B,C,D,Q,R)$.

In this case the matrix of weights Q relate the outputs y instead of the state x . For the servomechanism D is the row matrix with two zero elements. The function *lqry* computes the equivalent Q , R and calls *lqr*,

The control u is not constrained. This assumption can not be satisfied for a real physical system. One must remember that if the control u saturates then it not satisfies the LQ problem. To return to the LQ problem the amplitude of the u signal should be diminished. In such a case a designer tunes the relative weights between state and control variables. To perform that the simulation tools are recommended.

EXAMPLE

The goal of the control is to track a reference signal which is defined as a square wave. Set the amplitude of the reference input signal equal to $25\pi/2$. Set the frequency of the reference input to 0.1 Hz and sample time to 0.002 [s].

Type *Servo* at the MATLAB prompt and then double click the *State feedback control continuous* button. To design LQ controller click the *Calculate LQ controller* button. It executes *servo_calc_lq.m* file presented below:

```
% State space representation of servo:
A=[0 1;0 -1/Ts];
B=[0; Ks/Ts];
C = [1 0;0 1];
D = zeros( 2, 1 );

% Set Q and R matrices. These values can be changed by a user
Q=[50 0;0 1];
R=1000;

% calculate coefficients of the LQ controller
[K,S,lambda]=lqry(A,B,C,D,Q,R);

% type K in Matlab command window
K
```

For the default values: $K_s = 186$ [rad/s] and $T_s = 1.04$ [s] we obtain $K = [0.2236 \ 0.054]$.

To perform the real-time experiment click the *State feedback controller* button. When the model opens (see Fig. 7.26), check parameters of the reference signal. Build the model, click *Simulation/connect to target* and *Start real-time code* option to start experiment. The results are given in Fig. 7.27. Notice that the reference signal is reached with accuracy equal to 0.58% and without overshoots. The control signal saturates.

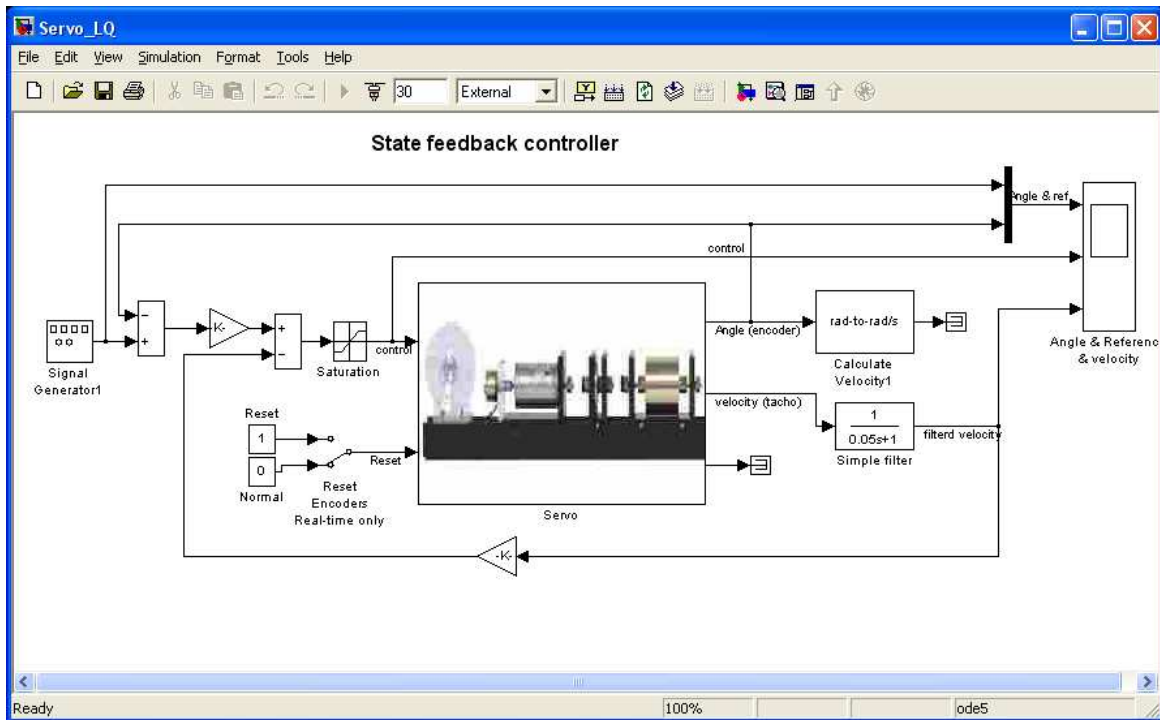

Fig. 7.26 Real-time model of the servo with the LQ controller

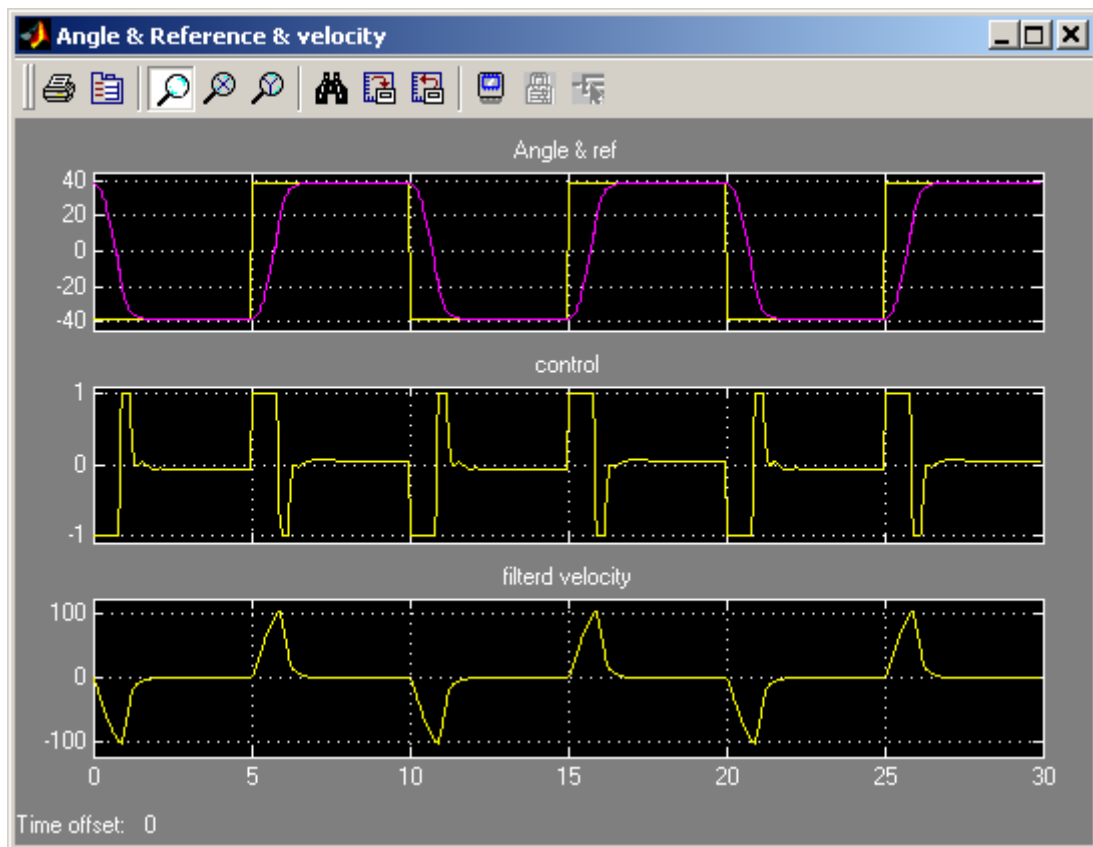

Fig. 7.27 Results of the position control with a continuous LQ controller

7.4.2. The discrete case

If we introduce the sampling period T_0 then the model can be discretized. The discrete model of the DC motor has the form:

$$\begin{aligned} x[(n+1)T_0] &= A_D x[nT_0] + B_D u[nT_0] \\ y[nT_0] &= C_D x[nT_0]. \end{aligned} \quad (7.5)$$

where the matrices: A_D , B_D and C_D are in the form

$$A_D = e^{AT_0} = \begin{bmatrix} 1 & T_s(1 - e^{-\frac{T_0}{T_s}}) \\ 0 & e^{-\frac{T_0}{T_s}} \end{bmatrix}, \quad B_D = \begin{bmatrix} K_s(T_0 - T_s(1 - e^{-\frac{T_0}{T_s}})) \\ K_s(1 - e^{-\frac{T_0}{T_s}}) \end{bmatrix}.$$

The matrix A_D is the fundamental solution of the differential equation (7.5) calculated for the sampling period T_0 . The explicit values of the matrices A_D and B_D of the servo system can be obtained numerically by the use of *c2d* function. *C2d* converts a continuous state representation to the discrete corresponding to the continuous. The procedure is a part of *Control System Toolbox*. One must simply type the command:

$$[A_D, B_D] = c2d(A, B, T_0)$$

The optimal feedback law:

$$u[nT_0] = Ke[nT_0], \quad e[nT_0] = y_d - y[nT_0]$$

minimizes the cost function:

$$J(u) = \sum_{n=0}^N [e^T(n)Q(n)e(n) + u^T(n)Ru(n)] \quad (7.6)$$

subject to the state equation (7.5). The *dlqry* function from the *Control System Toolbox* is used to solve the discrete-time linear-quadratic control problem. The synopsis of the *dlqry* and *lqry* programs are identical. The *dlqr* also solves and returns matrix S , the unique positive definite solution to the associated discrete iterative matrix Riccati equation:

$$S_{i+1} = A_D^T S_i A_D - A_D^T S_i B_D (R + B_D^T S_i B_D)^{-1} B_D^T S_i A_D + Q.$$

The feedback matrix is derived from S by

$$K = (R + B_D^T S B_D)^{-1} B_D^T S A_D$$

EXAMPLE

A goal of the control is the same as in the continuous case example. Assume that sampling time for discrete system $T_0 = 0.1$ [s].

In *Servo Control Window* double click the *State feedback control discrete* button. To design the LQ controller click the *Calculate LQ controller* button. It executes the *servo_calc_lq_d.m* file presented below.

```
% State space representation of servo:
A=[0 1;0 -1/Ts];
B=[0; Ks/Ts];
C = [1 0;0 1];
D = zeros( 2, 1 );

% set sampling time
T0=0.1;
% calculate discrete model from continuous
[Ad,Bd]=c2d(A,B, T0)

% set Q and R matrices
Q=[50 0;0 1];
R=1000;

% design discrete LQ controller

[K,S,lambda]=dlqry(Ad,Bd,C,D,Q,R);
K
```

For the default values: $K_s = 186$ [rad/s] and $T_s = 1.04$ [s] we obtain $K = [0.139 \ 0.0395]$.

To perform the real-time experiment click the *State feedback controller* button and the model shown in Fig. 7.24 opens. It is the same model as was previously applied to the deadbeat control. Set the frequency of the reference signal to 0.1 [Hz] the simulation time to 30 [s] and the time range of the scope to 30 [s]. These settings correspond to the values which have been assumed for the continuous LQ controller. Build model, click the *Simulation/connect to target* and the *Start real-time code* options to start experiment.

The results are shown in Fig. 7.27. They are similar to these for the continuous controller. The reference signal is reached with accuracy equal to 1% and without overshoots. The control signal saturates as in the previous example.

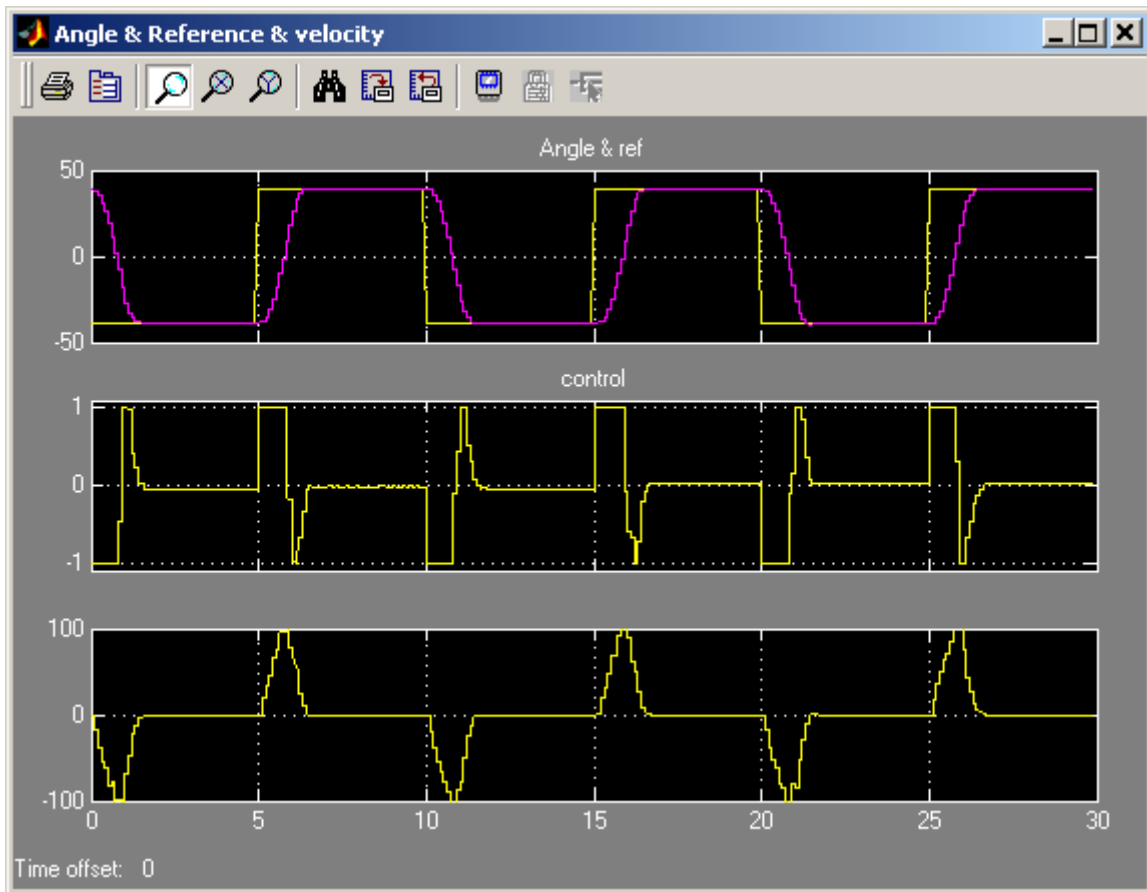

Fig. 7.28 Results of the position control by the discrete LQ controller

8. Description of the Modular Servo class properties

The *CServo* is a MATLAB class, which gives the access to all the features of the RT-DAC/PCI board equipped with the logic for the MSS model. The RT-DAC/PCI board is an interface between the control software executed by a PC computer and the power-interface electronic of the modular servo model. The logic on the board contains the following blocks:

- incremental encoder registers – two 24-bit registers to measure the position of the incremental encoders. There are two identical encoder inputs, that may be applied to measure the shaft positions of two modular servo blocks;
- incremental encoder reset logic. The incremental encoders generate different output waves when the encoder rotates clockwise and counter-clockwise. The encoders are not able to detect the reference (“zero”) position. To determine the “zero” position the incremental encoder registers have to be set to zero by the computer program;
- PWM generation block – generates the Pulse-Width Modulation output signal. Simultaneously the direction signal and the brake signal are generated to control the power interface module. The PWM prescaler determines the frequency of the PWM wave,
- power interface thermal flags –the thermal flags can be used to disable the operation of the overheated power amplifier,
- interface to the on-board analog-to-digital converter. The A/D converter is applied to measure the position of the external potentiometer and to measure the output voltage of the tachogenerator.

All the parameters and measured variables from the RT-DAC/PCI board are accessible by appropriate properties of the *CServo* class.

In the MATLAB environment the object of the *CServo* class is created by the command:

```
object_name = CServo;
```

The *get* method is called to read a value of the property of the object:

```
property_value = get( object_name, 'property_name' );
```

The *set* method is called to set new value of the given property:

```
set( object_name, 'property_name', new_property_value );
```

The *display* method is applied to display the property values when the *object_name* is entered in the MATLAB command window.

This section describes all the properties of the *CServo* class. The description consists of the following fields:

Purpose	Provides short description of the property
Synopsis	Shows the format of the method calls
Description	Describes what the property does and the restrictions subjected to the property
Arguments	Describes arguments of the set method
See	Refers to other related properties
Examples	Provides examples how the property can be used

8.1. BaseAddress

Purpose: Read the base address of the RT-DAC/PCI board.

Synopsis: *BaseAddress = get(sv, 'BaseAddress');*

Description: The base address of RT-DAC/PCI board is determined by computer. Each *CServo* object has to know the base address of the board. When a *CServo* object is created the base address is detected automatically. The detection procedure detects the base address of the first RT-DAC/PCI board plugged into the PCI slots.

Example: Create the *CServo* object:

```
sv = CServo;
```

Display their properties by typing the command:

```
sv
```

```
Type:                CSERVO Object
BaseAddress:         54272 / D400 Hex
Bitstream ver.:     x402
Encoder:             [ 0 46606 ][bit]
Reset Encoder:      [ 0 0 ]
Input voltage:      [ 0.1123 0.1123 ][V]
PWM:                 [ 0 ]
PWM Prescaler:      [ 0 ]
Thermal status:     [ 0 ]
Thermal flag:       [ 1 ]
Angle:              [ 0 71.4927 ][rad]
Time:               31.657 [sec]
```

Read the base address:

```
BA = get( sv, 'BaseAddress' );
```

8.2. BitstreamVersion

Purpose: Read the version of the logic stored in the RT-DAC/PCI board.

Synopsis: *Version = get(sv, 'BitstreamVersion');*

Description: The property determines the version of the logic design of the RT-DAC/PCI board. The modular servo models may vary and the detection of the logic design version makes it possible to check if the logic design is compatible with the physical model.

8.3. Encoder

Purpose: Read the incremental encoder registers.

Synopsis: `enc = get(sv, 'Encoder');`

Description: The property returns two digits. They are equal to the number of impulses generated by the corresponding encoders. The encoder counters are 24-bit numbers so the values of this property is from (-2^{24}) to $(2^{24}-1)$. When an encoder counter is reset the value is set to zero.
The incremental encoders generate 4096 pulses per rotation. The values of the *Encoder* property should be converted into physical units.

See: *ResetEncoder, Angle, AngleScaleCoeff*

8.4. Angle

Purpose: Read the angle of the encoders.

Synopsis: `angle_rad = get(sv, 'Angle');`

Description: The property returns two angles of the corresponding encoders. To calculate the angle the encoder counters are multiplied by the values defined as the *AngleScaleCoeff* property. The angles are expressed in radians.

See: *Encoder, AngleScaleCoeff*

8.5. AngleScaleCoeff

Purpose: Read the coefficients applied to convert the encoder counter values into physical units.

Synopsis: `scale_coeff = get(sv, 'AngleScaleCoeff');`

Description: The property returns two digits. They are equal to the coefficients applied to convert encoder impulses into radians. The incremental encoders generate 4096 pulses per rotation so the coefficients are equal to $2*\pi/4096$.

See: *Encoder, Angle*

8.6. PWM

Purpose: Set the direction and duty cycle of the PWM wave.

Synopsis: `PWM = get(sv, 'PWM');`
`set(sv, 'PWM', NewPWM);`

Description: The property determines the duty cycle and direction of the PWM wave. The PWM wave and the direction signals are used to control the DC drive so in fact this property is responsible for the DC motor control signal. The *NewPWM* variable is a scalar in the range from -1 to 1. The value of -1, 0.0 and +1 mean respectively: the maximum control in a given direction, zero control and the maximum control in the opposite direction to that defined by -1.

The PWM wave is not generated if the thermal flag is set and the power amplifier is overheated.

See: *PWMPrescaler, Therm, ThermFlag*

Example: `set(sv, 'PWM', [-0.3]);`

8.7. PWMPrescaler

Purpose: Determine the frequency of the PWM wave.

Synopsis: `Prescaler = get(sv, 'PWMPrescaler');`
`set(sv, 'PWMPrescaler', NewPrescaler);`

Description: The prescaler value can vary from 0 to 63. The 0 value generates the maximal PWM frequency. The value 63 generates the minimal frequency. The frequency of the generated PWM wave is given by the formula:

$$PWM_{\text{frequency}} = 40\text{MHz} / 1023 / (\text{Prescaler} + 1)$$

See: *PWM*

8.8. Stop

Purpose: Sets the control signal to zero.

Synopsis: `set(sv, 'Stop');`

Description: This property can be called only by the set method. It sets the zero control of the DC motor and is equivalent to the `set(sv, 'PWM', 0)` call.

See: *PWM*

8.9. ResetEncoder

Purpose: Reset the encoder counters.

Synopsis: `set(sv, 'ResetEncoder', ResetFlags);`

Description: The property is used to reset the encoder registers. The *ResetFlags* is a 1x2 vector. Each element of this vector is responsible for one encoder register. If the element is equal to 1 the appropriate register is set to zero. If the element is equal to 0 the appropriate register counts encoder impulses.

See: *Encoder*

Example: To reset only the first encoder register execute the command:
`set(sv, 'ResetEncoder', [1 0]);`

8.10. Voltage

Purpose: Read two voltage values.

Synopsis: `Volt = get(sv, 'Voltage');`

Description: Returns the voltage of two analog inputs. Usually the analog inputs are applied to measure the position of the external potentiometer and the output of the tachogenerator.

8.11. Therm

Purpose: Read thermal status flag of the power amplifier.

Synopsis: `Therm = get(sv, 'Therm');`

Description: Returns the thermal flag of the power amplifier. When the temperature of a power amplifier is too high the flag is set to 1.

See: *ThermFlag*

8.12. ThermFlag

Purpose: Control an automatic power down of the power amplifiers.

Synopsis: `ThermFlag = get(sv, 'ThermFlag');`
`set(sv, 'ThermFlag', NewThermFlag);`

Description: If the *ThermFlag* and *NewThermFlag* are both equal to 1 the DC motor is not excited by the PWM wave when the power interface is overheated.

See: *Therm*

8.13. Time

Purpose: Return time information.

Synopsis: $T = get(sv, 'Time');$

Description: The *CServo* object contains the time counter. When a *CServo* object is created the time counter is set to zero. Each reference to the *Time* property updates its value. The value is equal to the number of milliseconds which elapsed since the object was created.

8.14. Quick reference table

Property name	Operation*	Description
<i>BaseAddress</i>	R	Read the base address of the RT-DAC/PCI board
<i>BitstreamVersion</i>	R	Read the version of the logic design for the RT-DAC/PCI board
<i>Encoder</i>	R	Read the incremental encoder registers
<i>Angle</i>	R	Read the angles of the encoders
<i>AngleScaleCoeff</i>	R	Read the coefficient applied to convert encoder positions into radians
<i>PWM</i>	R+S	Read/set the parameters of the PWM waves
<i>PWMPrescaler</i>	R+S	Read/set the frequency of the PWM waves
<i>Stop</i>	S	Set the control signal to zero
<i>ResetEncoder</i>	R+S	Reset the encoder counters or read the reset flags
<i>Voltage</i>	R	Read the input voltages
<i>Therm</i>	R	Read the thermal flags of the power amplifiers
<i>ThermFlag</i>	R+S	Read/set the automatic power down flag of the power amplifier
<i>Time</i>	R	Read time information

- R – read-only property, S – allowed only set operation, R+S –property may be read and set

8.15. CServo Example

To familiarise a reader with the *CServo* class this section presents an M-file example that uses the properties of the *CServo* class to measure the static characteristics of the DC

motor (see section 6). The static characteristics is a diagram showing the relation between DC motor control signal and the motor shaft velocity. The M-file changes the control signal and waits until the MSS reaches steady-state. The velocity of the shaft is obtained in two ways:

- the M-file measures the output voltage from the tachogenerator,
- the M-file measures the encoder position in two time points and calculates the velocity as the difference of positions divided by the time period between the time points.

The M-file is written in the M-function form. The name of the M-function is *Servo_PWM2RPM*.

The function requires two parameters:

- *CtrlDirection* - a string that selects how to change the control value. The 'A' string causes the control is changed in ascending manner (from -1 to 1), the 'D' string causes the control is changed in descending order (from 1 to -1) and the 'R' string causes reverse double changes (from -1 to +1 and after that from +1 to -1),
- *MinControl*, *MaxControl* – minimal and maximal control signal values. The control signal changes within the region defined by these values,
- *NoOfPoints* - number of characteristics points within the *MinControl/MaxControl* range. The exact number of points of the characteristics declared by this parameter is enlarged to two points namely: *MinControl* and *MaxControl*.

The body of this function is given below. The comments within the function describe the main stages.

```
function ChStat = Servo_PWM2RPM( ...
    CtrlDirection, MinControl, MaxControl, NoOfPoints )

CtrlDirection = lower( CtrlDirection );
NoOfPoints     = max( 1, NoOfPoints+1 );

% Calculate control step
Step = (MaxControl-MinControl) / NoOfPoints;

switch CtrlDirection
    case 'a'
        Ctrl = MinControl:Step:MaxControl;
    case 'd'
        Ctrl = MaxControl:-Step:MinControl;
    case 'r'
        Ctrl = [ MinControl:Step:MaxControl MaxControl:-Step:MinControl];
    otherwise % This should not happen
        error('The CtrlDirection must be 'A','D' or 'R'.')
end

FigNum = figure( 'Visible', 'on', ...
    'NumberTitle', 'off', ...
    'Name', 'Velocity vs. PWM characteristic', ...
    'Menubar', 'none' );

sv = cservo;
Control = [];
VelEnc = [];
% Optionally set the PWM prescaler
%set( sv, 'pwmprescaler', 20);
```



```

for i=1:length(Ctrl)
    % Set a new control value
    set( sv, 'PWM', Ctrl(i) );
    % Reset encoders
    set( sv, 'ResetEncoder', [1 1] );
    set( sv, 'ResetEncoder', [0 0] );
    pause( 5 )
    AuxEnc = get( sv, 'Encoder' ); TimeBeg=gettime;
    pause( 2 )
    % Calculate velocity based on the encoder positions
    VelEnc(i,:) = 2*pi*(get( sv, 'Encoder' )-AuxEnc)/ ...
                4096/((gettime-TimeBeg)/1000); % [rad/s]
    Control(i) = get( sv, 'PWM' );
    Volt(i,:) = get( sv, 'Voltage' );

    % Perform 10000 A/D conversions and calculate average values
    AuxVolt = [0 0];
    for j=1:10000
        AuxVolt = AuxVolt + get( sv, 'Voltage' );
    end
    Volt(i,:) = AuxVolt/10000;
    % Convert voltage into velocity
    Volt2Vel = 20.4*Volt(:,2);
    % Plot data
    subplot(211);
    plot( Control, VelEnc(:,2), Control, VelEnc(:,2), 'x' ); grid
    title( 'Encoder velocity vs. PWM' );
    xlabel('PWM control value'); ylabel( 'Velocity [rad/s]' );
    subplot(212);
    plot( Control, Volt2Vel, Control, Volt2Vel, 'x' ); grid
    title( 'Tacho velocity vs. PWM' );
    xlabel('PWM control value'); ylabel( 'Tacho velocity [rad/s]' );
end
% Assign data to the structure returned by the function
ChStat.Control = Control;
ChStat.TachoVelocity = VelEnc(:,2);
ChStat.EncoderVelocity = Volt2Vel;

% Switch off the control
set( sv, 'Stop' );

```

The diagrams generated by the call

```
servo_pwm2rpm('r',-0.5,0.5,19),
```

are shown below. The diagrams present the velocity of the shaft as function of the control signal. The control signal changes from -0.5 to $+0.5$. The velocity value is obtained in two ways. At the upper diagram the velocity is calculated from the encoder positions. The lower diagram presents the velocity obtained from the tachogenerator.

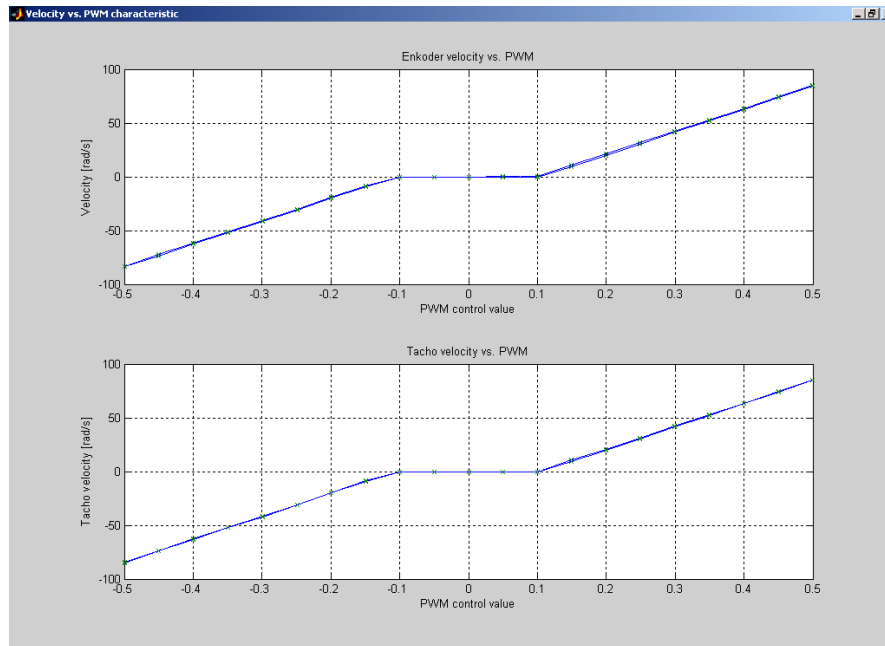

Fig. 8.1 Result of the *servo_pwm2rpm* function call

The values on the diagram may vary from an experiment to an experiment as they depend on the configuration of the modular servo set-up.

9. Some technical data

Brass inertia load 2.030 kg	0.055 kg Aluminium wheels 0.05 kg

Fig. 9.1 Dimensions and weights of the MSS mechanical elements



Data sheet of the DC motor is available at

<http://www.buehlermotor.com/cgi-bin/sr.exe/productpageus&productpage=54>

The gearbox ratio $N = 25$