



DIRECT FIRED DIGITAL TEMPERATURE CONTROL INSTALLATION, OPERATION, AND MAINTENANCE MANUAL



This manual covers the following products:

- DFC-1 Standard direct fired temperature control 0-24VDC output
- DFC-2 Direct fired control with integral 40-90°F (4-32°C) dial 0-24VDC output
- DFTS Temperature sensor 40-250°F (4-121°C)
- DFTD-XXXX Temperature dial 5 selectable ranges
- DAT-12 Discharge air tube
- PWM-10V PWM to 10V output converter

Table of Contents

Overview.....	2
Specifications.....	2
Power Requirements.....	2
DFC Ambient Temperature Limits.....	2
DFTS/DFTD Ambient Temperature Limits	2
Accuracy	2
Installation.....	2
Wiring.....	2
Standard control with remote set point.....	2
Standard control with integral set point.....	3
Optional room space control	3
Optional multiple set point temperature control.....	3
Operation.....	4
Start up	4
Sequence of operation.....	4
Calibration	4
Troubleshooting.....	4
DFTS and DFTD Resistance chart.....	4

Overview

The Roof Top Control Solutions direct fired digital temperature control is a microprocessor based control that utilizes an intelligent PID software algorithm to modulate gas flow to a burner in direct fired make up air applications. The closed loop system contains three components including the direct fired temperature sensor (DFTS), the direct fired control (DFC), and the direct fired temperature dial (DFTD). The system compares the discharge temperature of the heating unit to the set point dial 40 times per second insuring accurate and repeatable temperature control. The software provides smooth output control eliminating excessive swings observed with older analog systems. A 10 second start up delay is standard, and an onboard LED indicates simple diagnostics.

Specifications

Power Requirements	24VAC 50/60Hz 20VA isolated class II transformer
DFC Ambient Temperature Limits	
Storage	
Operating	-40-140°F (-40-60°C)
DFTS/DFTD Ambient Temperature Limits	
Storage	-40-140°F (-40-60°C)
Operating	
Accuracy	
	-40-250°F (-40-121°C)
	-40-250°F (-40-121°C)
	+/-3°F (1°C)

Installation

All control wiring should be shielded with the shielding grounded and/or the wiring should be run in separate conduit from any high voltage wires. Interference from these sources could cause control function errors or permanent damage. The DFC control should be mounted in a housing free from the elements of weather. Insulated fork terminal terminations are recommended for best contact when attaching wiring to the provided screw terminals. Models DFC-1 and DFC-2 can drive up to a .5 amp 24VDC direct acting solenoid.

The DFTD can be set to 5 different temperature ranges by moving jumper J1 as shown in Figure 1 on the back of the dial to the desired position. 5 different temperature overlays are available to match the range chosen.

**** Important! When using the PWM-10V output converter to connect the DFC to a motorized actuator, or any other device with it's own power supply, the DFC must have it's own isolated transformer separate from the power source for the actuator, or the control may be damaged.**

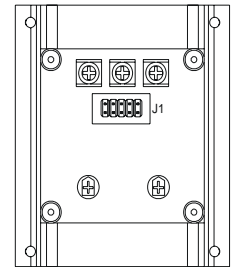

Figure 1

Wiring

Standard control with remote set point

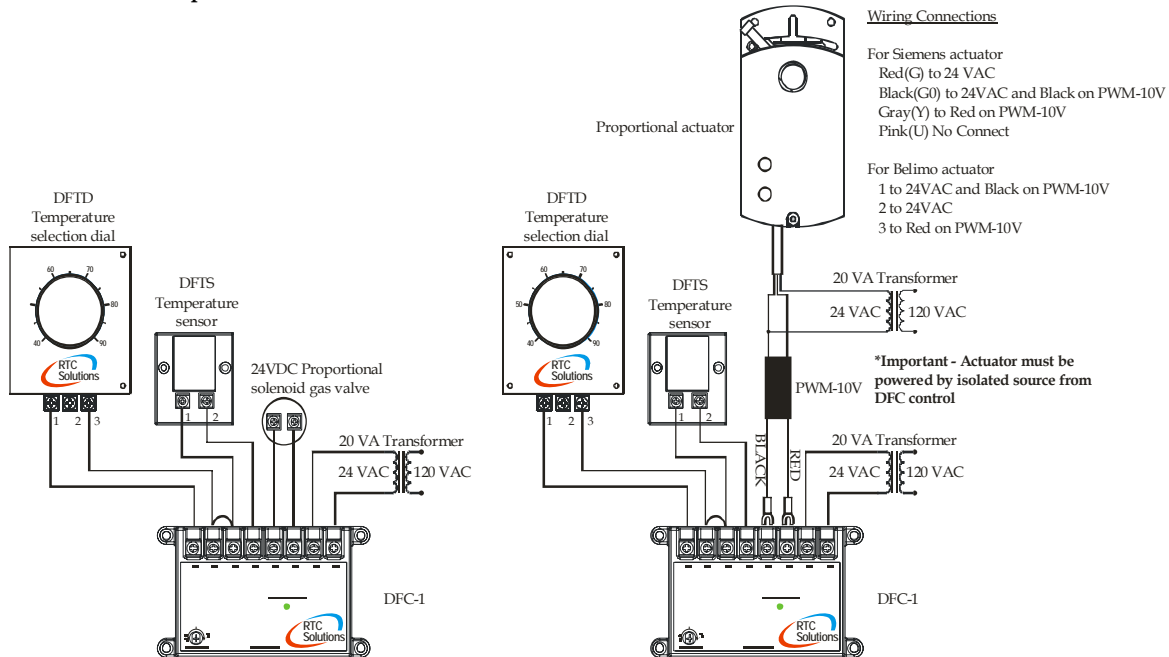

Figure 2 - Standard control wiring showing output options

Standard control with integral set point

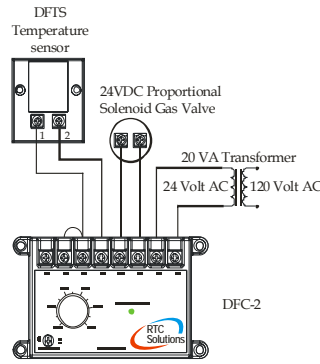

Figure 3 - Control with integral setpoint

Optional room space control

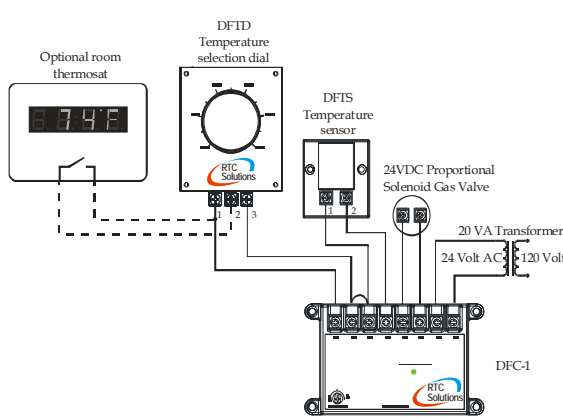

Figure 4 - Room space control with thermostat

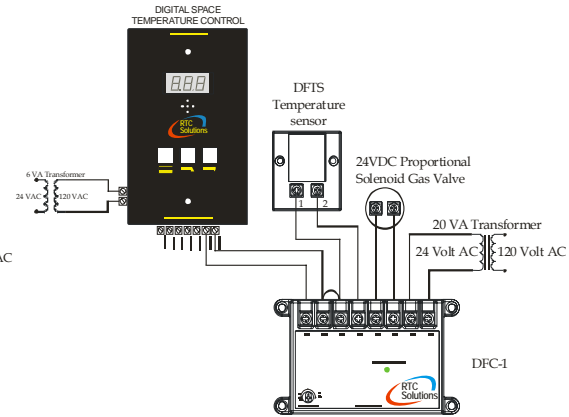

Figure 5 - Room space control with digital space control

A standard make or break thermostat with normally open contacts can be connected between terminals 1 and 2 as shown in Figure 4. When connected in this way the thermostat may be set for a desired room temperature for space control applications. Potentiometer R1 on the back of the DFTD sets how much the temperature will increase by when the room thermostat calls for more heat. When the room thermostat is satisfied, the discharge temperature will return to the temperature set on the dial on the front of the DFTD. For proportional room space control, the DFC-1 can be connected as shown in Figure 5. See RTC-1 literature for details.

Optional multiple set point temperature control

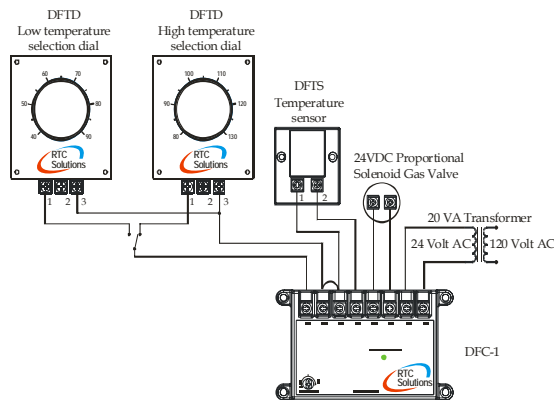

Figure 6 - Control with multiple set points

More than one temperature dial can be connected as shown in Figure 3 for applications such as paint spray booths or process control.

Operation

Start up

Setting low fire - The minimum firing rate may be set by removing the wire from terminal number 6 on the DFC control. This disconnects the power to the control valve. Refer to the control valve manufactures literature for this adjustment.

Setting high fire – The maximum firing rate may be set by removing the wire from terminal number 4 on the DFC control. This disconnects the discharge air sensor and sets the output to the control valve to it's maximum. Refer to the control valve manufactures literature for this adjustment.

Sequence of operation

Upon applying power to the DFC control the 10 second start up delay will begin indicated by a slow blinking LED (about once every 2 seconds) on the face of the control. After the start up delay has completed, the LED will turn solid and the control will begin modulating the output as required. Any system errors are indicated by a fast blinking LED (about twice per second) for instance when the discharge air sensor is disconnected or outside of the normal operating range.

Calibration

The temperature control should maintain an accuracy of +/- 3°F (1°C). In the event that the discharge is inaccurate due to duct losses the control may be calibrated in two ways. The potentiometer on the face of the DFC labeled "ADJUST" will adjust the discharge temperature by +/- 10°F (5°C) when rotated. Rotating it clockwise will increase the temperature and counter clockwise will decrease the temperature. The system may also be adjusted from the DFTD if installed by adjusting potentiometer R3 on the back in the same manner as the DFC procedure above.

Troubleshooting

The DFC control provides some diagnostics via the on board LED labeled "POWER/STATUS". A system fault is indicated by a fast blinking LED (about twice per second). This usually indicates that the sensor or dial are either disconnected or improperly wired. Check all connections per the included wiring diagrams. The fault also may be caused by a damaged sensor or dial. Both devices may be tested with an Ohmmeter by removing the wires from the DFC control and measuring across the device. The devices should measure between 12.8K and 7K OHMS. If there is a fault light and the devices measure the proper resistance then the control may be damaged. If there is no fault light but the system is not modulating properly you may check the control output by repeating the start up procedure and measuring terminals 5 and 6 on the DFC as follows.

For DFC-1 and DFC-2

Remove the wire from terminal number 4 on the DFC control and measure the voltage across terminals 5 and 6 with a voltmeter. The meter should read from 20 to 24 Volts. If it does not, disconnect the wires from the valve and measure the output without the valve connected. If it reads 20 to 24 Volts, refer to the valve manufactures literature for troubleshooting the valve. If it does not the control may be damaged.

DFTS and DFTD Resistance chart

Temp °F	Temp °C	Sensor Resistance	Dial Resistance				
			40-90	80-130	120-170	160-210	200-250
40	4.4	11214	11250				
50	10.0	11029	11050				
60	15.6	10835	10850				
70	21.1	10635	10650				
80	26.7	10429	10450	10380			
90	32.2	10219	10250	10180			
100	37.8	10005		9980			
110	43.3	9789		9780			
120	48.9	9573		9580	9590		
130	54.4	9356		9380	9390		
140	60.0	9142			9190		
150	65.6	8930			8990		
160	71.1	8723			8790	8700	
170	76.7	8521			8590	8500	
180	82.2	8325				8300	
190	87.8	8138				8100	
200	93.3	7959				7900	8060
210	98.9	7791				7700	7860
220	104.4	7634					7660
230	110.0	7490					7460
240	115.6	7360					7260
250	121.1	7246					7060