

Showline

SL eSTROBE I30 LED Luminaire



USER'S MANUAL

PHILIPS

Showline Offices

Showline - Dallas

10911 Petal Street
Dallas, TX 75238
Tel: 214-647-7880
Fax: 214-647-8030

Showline - Auckland

19-21 Kawana Street
Northcote, Auckland 0627
New Zealand
Tel: +64 9 481 0100
Fax: +64 9 481 0101

Showline - Europe

Marssteden 152
Enschede 7547 TD
The Netherlands
Tel: +31 53 4500424
Fax: +31 53 4500425

Showline - Asia

Unit C, 14/F, Roxy Industrial Centre
No. 41-49 Kwai Cheong Road
Kwai Chung, N.T., Hong Kong
Tel: +852 2796 9786
Fax: +852 2798 6545

Website:

www.Philips.com/Showline

The material in this manual is for information purposes only and is subject to change without notice. Showline assumes no responsibility for any errors or omissions which may appear in this manual. For comments and suggestions regarding corrections and/or updates to this manual, please visit the Showline website at www.philips.com/showline or contact your nearest Showline office.

El contenido de este manual es solamente para información y está sujeto a cambios sin previo aviso. Showline no asume responsabilidad por errores o omisiones que puedan aparecer. Cualquier comentario, sugerencia o corrección con respecto a este manual, favor de dirigirlo a la oficina de Showline más cercana.

Der Inhalt dieses Handbuches ist nur für Informationszwecke gedacht, Aenderungen sind vorbehalten. Showline uebernimmt keine Verantwortung für Fehler oder Irrtuemer, die in diesem Handbuch auftreten. Für Bemerkungen und Verbesserungsvorschlaege oder Vorschlaege in Bezug auf Korrekturen und/oder Aktualisierungen in diesem Handbuch, moechten wir Sie bitten, Kontakt mit der naechsten Showline-Niederlassung aufzunehmen.

Le matériel décrit dans ce manuel est pour information seulement et est sujet à changements sans préavis. La compagnie Showline n'assume aucune responsabilité sur toute erreur ou omission inscrite dans ce manuel. Pour tous commentaires ou suggestions concernant des corrections et/ou les mises à jour de ce manuel, veuillez s'il vous plait contacter le bureau de Showline le plus proche.

Note: Information contained in this document may not be duplicated in full or in part by any person without prior written approval of Showline. Its sole purpose is to provide the user with conceptual information on the equipment mentioned. The use of this document for all other purposes is specifically prohibited.

Document Number: **SL eSTROBE 130 User's Manual**

Version as of: 24-004-3590-00 Rev1.0

SL eSTROBE 130 LED Luminaire installation & User's Manual
© 2013 Philips Group. All rights reserved.

IMPORTANT INFORMATION

Warnings and Notices

When using electrical equipment, basic safety precautions should always be followed including the following:



- a. **READ AND FOLLOW ALL SAFETY INSTRUCTIONS.**
- b. Do not use outdoors.
- c. Do not mount near gas or electric heaters.
- d. Equipment should be mounted in locations and at heights where it will not readily be subject to tampering by unauthorized personnel.
- e. The use of accessory equipment not recommended by the manufacturer may cause an unsafe condition.
- f. Do not use this equipment for other than intended use.
- g. Refer service to qualified personnel.

SAVE THESE INSTRUCTIONS.



WARNING: You must have access to a mains circuit breaker or other power disconnect device before installing any wiring. BE sure that power is disconnected by removing fuses or turning the mains circuit breaker off before installation. Installing the device with power on may expose you to dangerous voltages and damage the device. A qualified electrician must perform this installation.

WARNING: Refer to National Electrical Code® and local codes for cable specifications. Failure to use proper cable can result in damage to equipment or danger to personnel.

WARNING: This equipment is intended for installation in accordance with the Nation Electric Code® and local regulations. It is also intended for installation in indoor applications only. Before any electrical work is performed, disconnect power at the circuit breaker or remove the fuse to avoid shock or damage to the control. It is recommended that a qualified electrician perform this installation.

Additional Resources for DMX512

For more information on installing DMX512 control systems, the following publication is available for purchase from the United States Institute for Theatre Technology (USITT), "Recommended Practice for DMX512: A Guide for Users and Installers, 2nd edition" (ISBN: 9780955703522). USITT Contact Information:

USITT
315 South Crouse Avenue, Suite 200
Syracuse, NY 13210-1844
Phone: 1.800.938.7488 or 1.315.463.6463
www.usitt.org

Showline Limited Two-Year Warranty

Showline offers a two-year limited warranty of its luminaires against defects in materials or workmanship from the date of delivery. A copy of Showline two-year limited warranty containing specific terms and conditions can be obtained by contacting your local Showline office.

TABLE OF CONTENTS

Showline Offices	Inside Front Cover
IMPORTANT INFORMATION	
Warnings and Notices	1
Additional Resources for DMX512	1
Showline Limited Two-Year Warranty	1
TABLE OF CONTENTS	
PREFACE	
About this Manual	3
Included Items	3
SL eSTROBE 130 LED LUMINAIRE OVERVIEW	
SL eSTROBE 130 LED Luminaire Components	4
Common Luminaire Components	4
LCD Display / Menu System	5
INSTALLATION AND SET UP	
Power Requirements	6
Connecting Power	6
Connecting to the DMX512 Network	6
Mounting Luminaire	7
Floor Mounting	7
Truss Mounting	7
OPERATION AND PROGRAMMING	
LCD Display and Menu System	8
SL eSTROBE 130 LED Luminaire	8
LCD Display and Menu System Operation	8
SL eSTROBE 130 LED Luminaire Menu Tree	10
Dimming Curve Selection	11
Master / Slave Operational Mode	12
DMX CONTROL	
SL eSTROBE 130 LED Luminaire DMX Mapping	13
Single Channel Mode	13
Three Channel Mode	13
Four Channel Mode	14
16-Bit Mode	15
Zone Mapping Mode	16
Strobe Rate	17
Strobe During	23
RDM PARAMETER IDs	
SL eSTROBE 130 LED Luminaire RDM Parameter IDs	28
CLEANING AND CARE	
Special Cleaning and Care Instructions	31
Front Lens Cleaning	31
Service and Maintenance	31
Accessories	32
TECHNICAL SPECIFICATIONS	
Operational Specifications	33
Luminaire Dimensions	34

PREFACE

1. About this Manual

The document provides installation and operation instructions for the following products:

- SL eSTROBE 130 LED Luminaire

Please read all instructions before installing or using this product. *Retain this manual for future reference.* Additional product information and descriptions may be found on the product specification sheet.

Note: The SL eSTROBE 130 LED Luminaire is universal voltage 100 to 240 VAC (auto-ranging).

2. Included Items



Each SL eSTROBE 130 LED Luminaire includes the following items:

- SL eSTROBE 130 LED Luminaire
- AC Power Input Cable
- Installation and User's Manual (*this document*)

SL eSTROBE 130 LED Luminaire Overview

1. SL eSTROBE 130 LED Luminaire Components

Common Luminaire Components

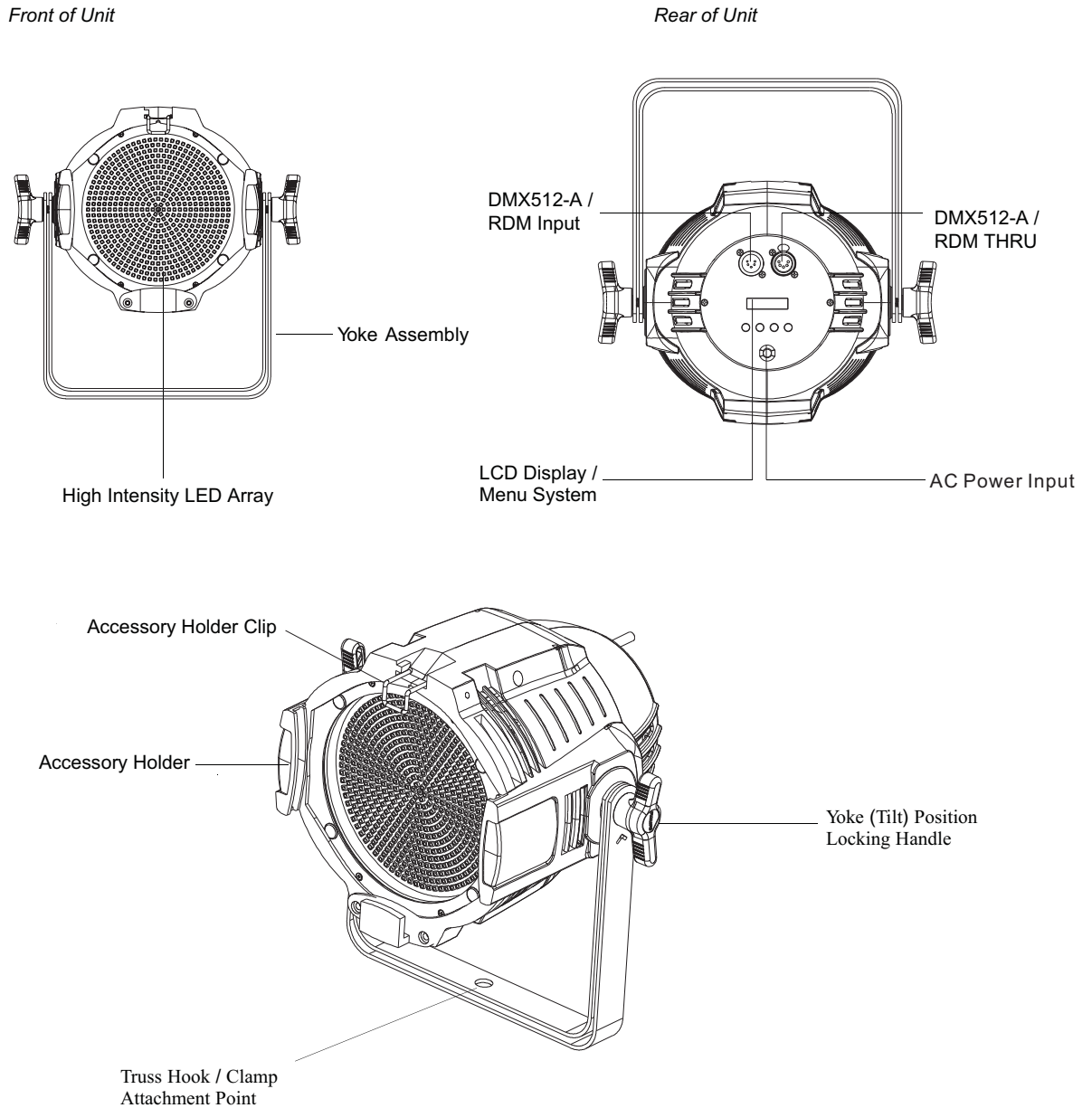

Figure 1: SL eSTROBE 130 LED Luminaire Components

LCD Display / Menu System

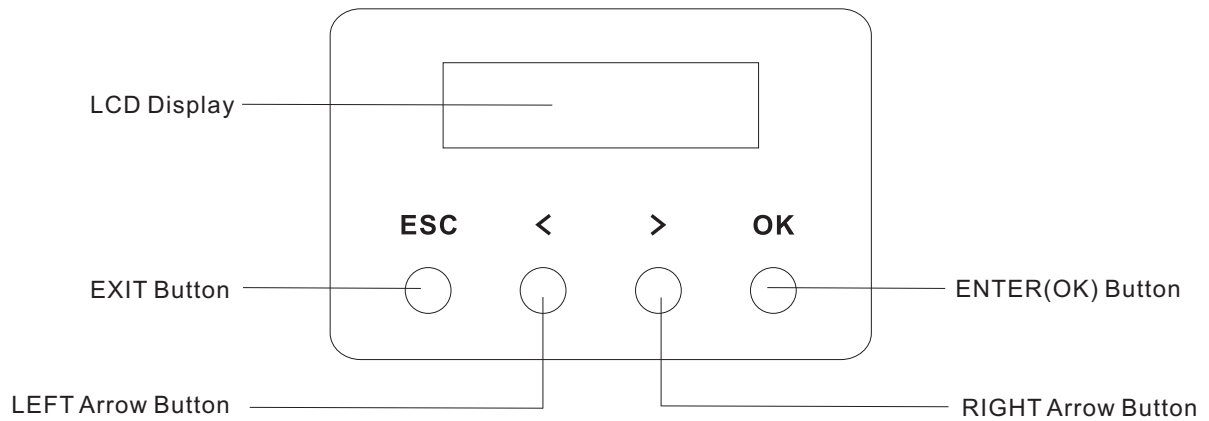

Figure 2: LCD Display & Menu System

Note: For Menu operation and programming details, refer to the "LCD Display and Menu System" on page 8.

INSTALLATION AND SET UP

1. Power Requirements

The SL eSTROBE 130 LED Luminaire operates on AC input voltages from 100 to 240 VAC.



WARNING! This luminaire does not contain an ON/OFF switch. Always disconnect power input cable to completely remove power from the luminaire when not in use.

AC Power Operation

When connected to an AC source, the luminaire operates on 100 to 240 volts AC (+/- 10%, auto-ranging). The luminaire contains an auto-ranging power supply. Each luminaire can draw up to 130 Watts.

Table 1: SL eSTROBE 130 Voltage (VAC) vs. Current

Voltage (AC)	Total Current (A)	Voltage (AC)	Total Current (A)
100	1.30	180	0.72
110	1.18	190	0.68
120	1.08	200	0.65
130	1.00	210	0.62
140	0.92	220	0.59
150	0.86	230	0.56
160	0.81	240	0.54
170	0.76		

2. Connecting Power

Direct connection to a AC power source using an AC input cable.

3. Connecting to the DMX 512 Network

Basic DMX512 installation consists of connecting multiple SL eSTROBE 130 LED luminaires together (up to 32 luminaires) in "daisy-chain" fashion. A cable runs from the control console (or DMX512 control source) to the DMX connector on the first SL eSTROBE 130 LED Luminaire. Another cable runs from the other DMX connector on the first Luminaire to a DMX connector on the next SL eSTROBE 130 LED Luminaire (or DMX512 device to be controlled).

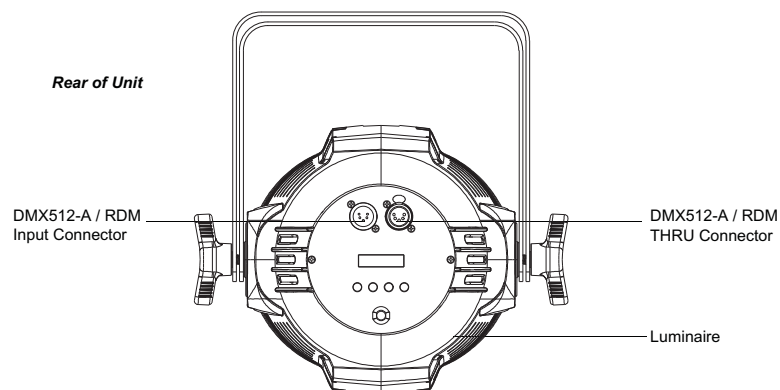

Figure 3: SL eSTROBE 130 LED Luminaire DMX512 Input / THRU Connections

Note: For more information on DMX512 networking and systems, refer to "Additional Resources for DMX512" on page 1. For SL eSTROBE 130 LED Luminaire DMX Mapping, refer to "DMX CONTROL" on page 13.

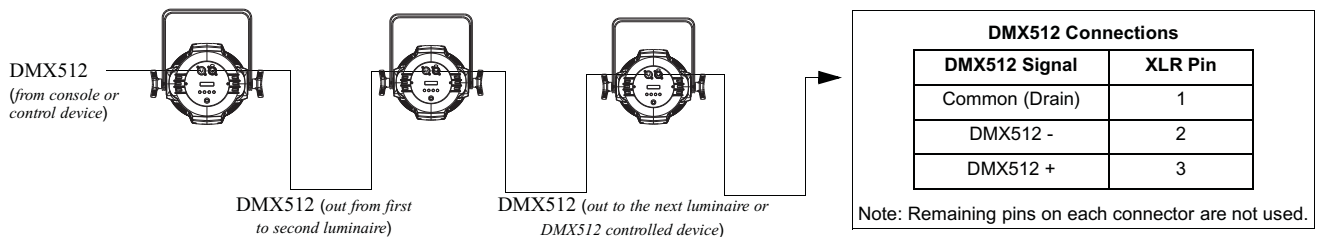

Figure 4: SL eSTROBE 130 LED Luminaire - DMX512 Connections

4. Mounting Luminaire

Floor Mounting

The SL eSTROBE 130 LED Luminaire is designed to sit directly on its yoke assembly in a floor installation application. When used in this type of application, loosen the locking handle securing the inner portion of the yoke assembly and separate out (as shown in **Figure 5**). Be sure to leave enough space around the luminaire to allow proper, uninterrupted airflow for cooling.

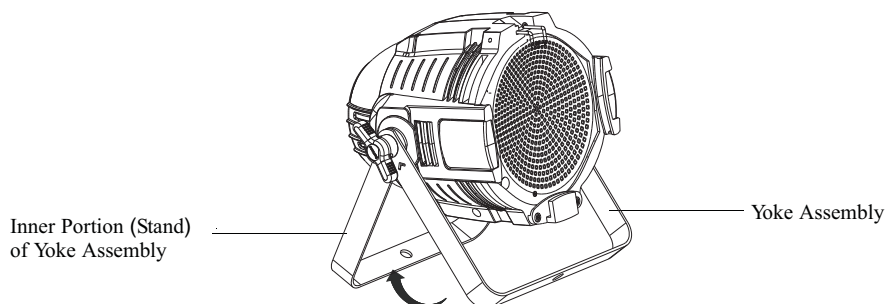

Figure 5: Floor Mounting

Truss / Hanging Applications

The SL eSTROBE 130 LED Luminaire is provided with the ability to hang via truss hooks, clamps, etc. (sold separately). Simply attach hook, clamp, etc. to the SL eSTROBE 130 LED Luminaire enclosure assembly in the provided M10 holes. It is recommended (and may be required by local and national safety codes) to use and install a safety cable (sold separately) as illustrated in **Figure 6**. When hanging the fixture, be sure to leave enough space around the luminaire to allow proper, uninterrupted airflow for cooling and positioning. Refer to "Luminaire Dimensions" on page 34 for spacing (dimensional) requirements.

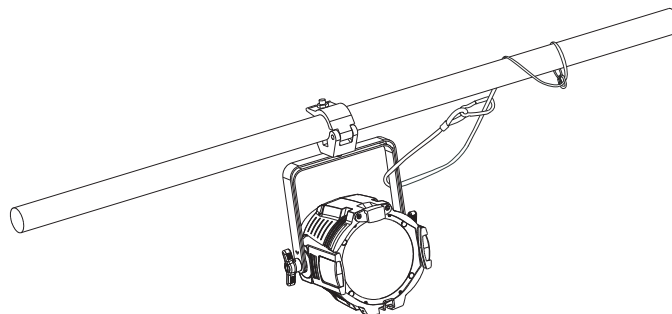

Figure 6: Truss Mounting

OPERATION AND PROGRAMMING

1. LCD Display and Menu System

SL eSTROBE 130 LED Luminaires

The SL eSTROBE 130 LED Luminaire's LCD Display and Menu System provides local control for accessing the following fixture's settings:

- Presets (Standard and User Defined)
- Chase
- Settings
- Status

Note: If there are multiple luminaires in a system, changes would need to be made at each LCD Menu as desired. For the SL eSTROBE 130 LED Luminaire menu structure, see "[SL eSTROBE 130 LED Luminaire Menu Tree](#)" on page 10.

Upon power up, the LCD will display the main screen display menu of SL eSTROBE 130 LED Luminaire. Press “<” or “>” to select then press 'OK' to enter.

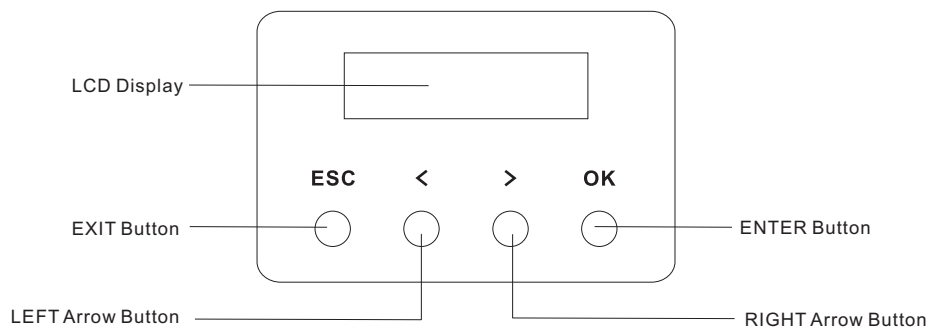

Figure 7: LCD Display and Menu System

2. LCD Display and Menu System Operation

The LCD Display Menu system consists of several categories. Upon power up, the LCD will display the main menu automatically. When the desired menu item is reached, press the OK button to display the menu options, and to navigate and configure the menu options as required.

To navigate and access the menu settings/selections:

- Step 1. Make sure the luminaire is powered and turned on.
- Step 2. Press the desired button to access the menu categories.
- Step 3. Use the “<” and “>” arrow buttons to navigate through the various options and settings.
- Step 4. Make changes as desired.

Press the OK button to accept changes.

Preset

To edit and save a preset

- Step 1. Press the OK button to access the Preset menu.
- Step 2. Use the LEFT and RIGHT arrow buttons to scroll through all presets and select the desired preset number.
- Step 3. Press the OK button to select the desired menu. In RGB mode, the user can select **Intensity, Strobe Rate, Duration, Effects, Zone1, Zone2, Zone3 and Zone4.**
- Step 4. Once at the desired preset, use the LEFT and RIGHT arrow buttons to adjust parameter value as desired. Once all values are adjusted as desired, press the OK button.
- Step 5. Press the ESC button to select Save a Preset, the screen will then display "Save Preset: x". Use the LEFT and RIGHT arrow buttons to make a selection, then press the OK button.
- Step 5. The preset is now saved. Press the ESC button to exit the current menu.

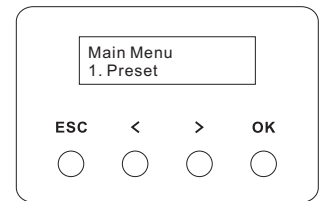

Chase

- Step 1. Select Chase and press the OK button to access.
- Step 2. Use the LEFT and RIGHT arrow buttons to scroll through all menus.
- Step 3. Select the Built-in Chase X(1-10) option or the User Chase(1-8) option, then press the OK button to select the desired menu.
- Step 4. Once at desired menu, use the LEFT and RIGHT arrow buttons to adjust the parameter value as desired. Once all values are adjusted as desired, press the OK button.
- Step 5. The chase is now saved. Press the ESC button to exit the current menu.

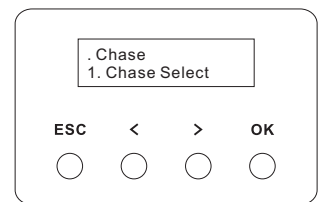

Settings

- Step 1. Press the OK button to access Settings.
- Step 2. Use the LEFT and RIGHT arrow buttons to scroll through all menus.
- Step 3. Press the OK button to select the desired menu among **General, Factory Default, DMX and Display.**
- Step 4. Once at desired menu, use LEFT and RIGHT arrow buttons to adjust the related fixture information. Once all values are adjusted as desired, press CHECK MARK (OK) button.
- Step 5. Adjustment is now saved. Press ESC button to exit current menu.

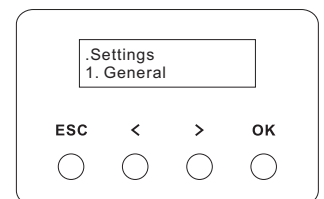

Status

To check the fixture operational status:

- Step 1. Press CHECK MARK(OK)button to access Status.
- Step 2. Use the LEFT and RIGHT arrow buttons to scroll through all menus.
- Step 3. Press the OK button to select the desired menu from **LED Level, Temperature, and Other Info.**
- Step 4. Once at the desired menu, use the LEFT and RIGHT arrow buttons to check the related fixture information.

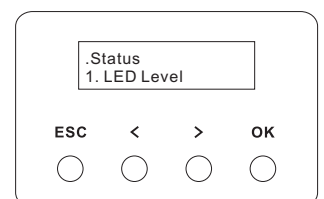

Note: For more information about Preset, Color Filter, Chase, Strobe/Timing, Settings and Status, please refer to the "SL eSTROBE 130 LED Luminaire Menu Tree" on page 11.

3. SL eSTROBE 130 LED Luminaire Menu Tree

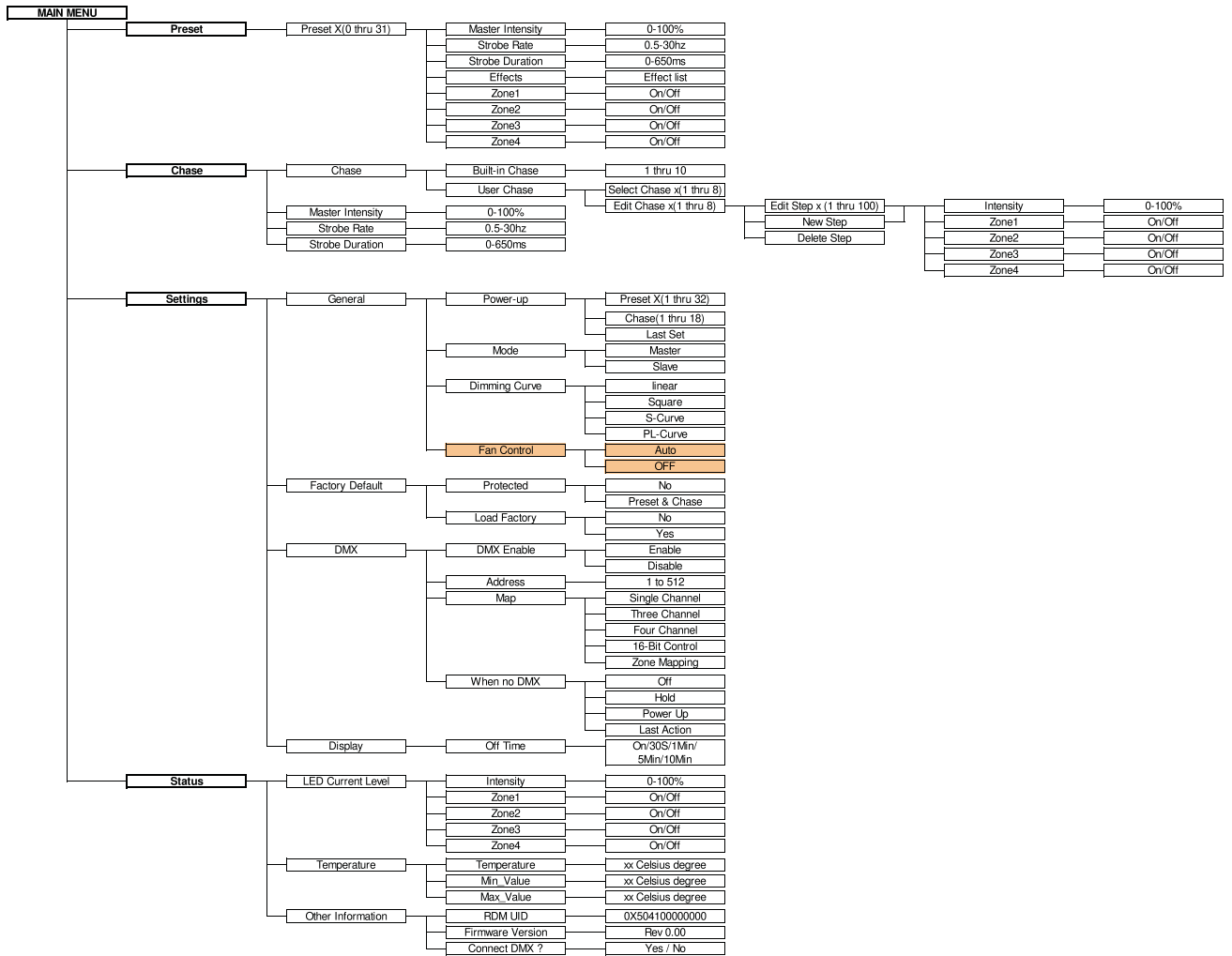
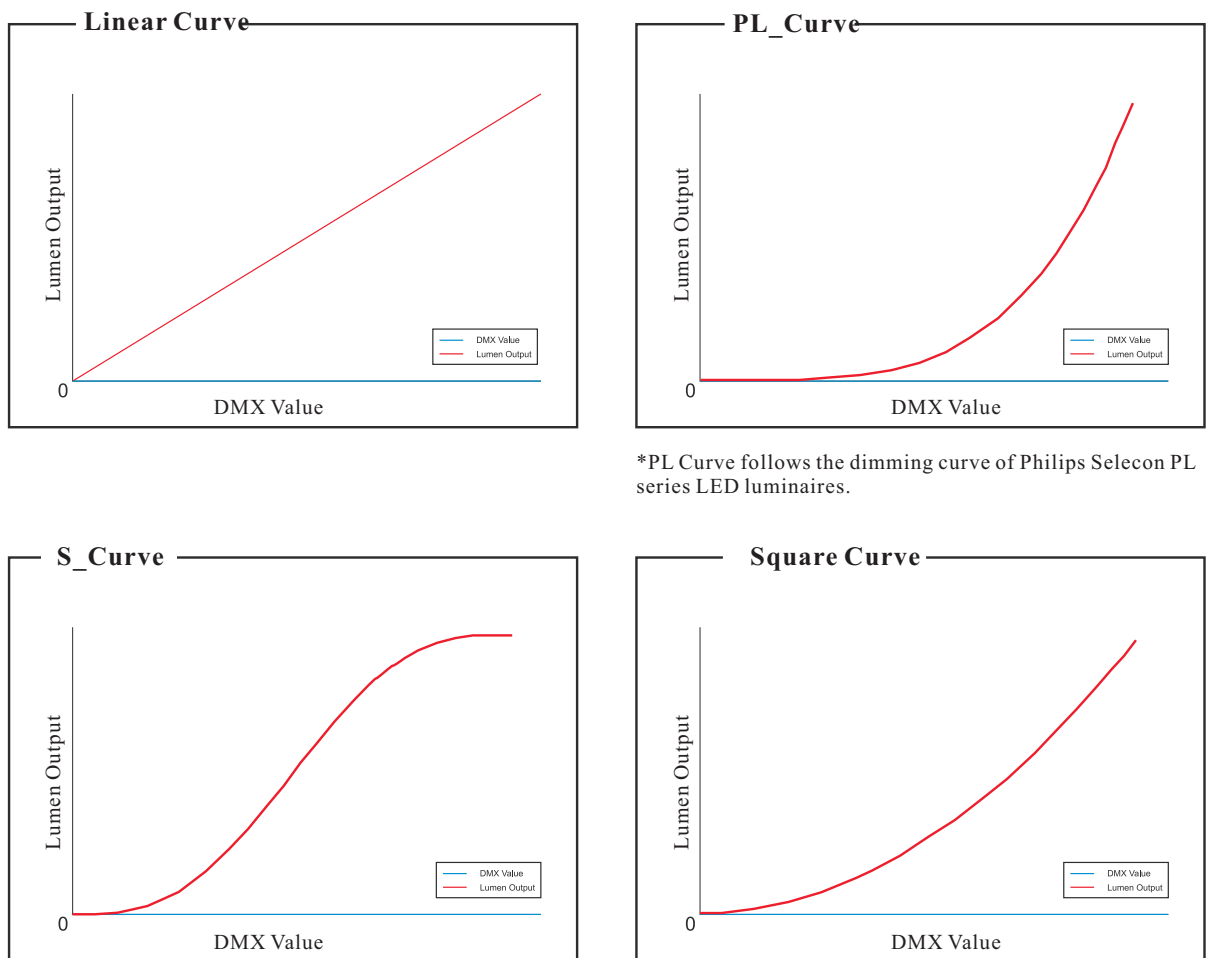

Figure 8: SL eSTROBE 130 LED Luminaire Menu Tree

4. Dimming Curve Selection

Through the menu, you are able to select one of four dimming curves:

- Linear Curve
- PL_Curve
- S_Curve
- Square Curve



*PL Curve follows the dimming curve of Philips Selecon PL series LED luminaires.

Figure 9: SL eSTROBE 130 LED Luminaire Dimmer Curves

5. Master / Slave Operational Mode

The Master / Slave Operational Mode allows one SL eSTROBE 130 LED Luminaire to act as the “Master” luminaire and all other connected luminaires are controlled by this master luminaire. When a luminaire is set to “Slave” mode, it will only luminaire and follow any commands send from a “Master” luminaire. Only one “Master” luminaire is allowed in this type of operation.

To setup a master / slave network:

- Step 1. Set the first luminaire in the DMX512 chain to **Master Mode** through the luminaire's menu system.
- Step 2. Set all other connected luminaires to **Slave Mode**.
- Step 3. The master luminaire can be controlled via DMX512, RDM or through standalone operation (a self-contained network utilizing on-board effects). The salve luminaires will mimic the master luminaire's operation in all cases.

Note: For more information on DMX512 networking and systems, refer to “[Additional Resources for DMX512](#)” on page 1. For SL eSTROBE 130 LED Luminaire DMX Mapping, refer to “[DMX CONTROL](#)” on page 13.

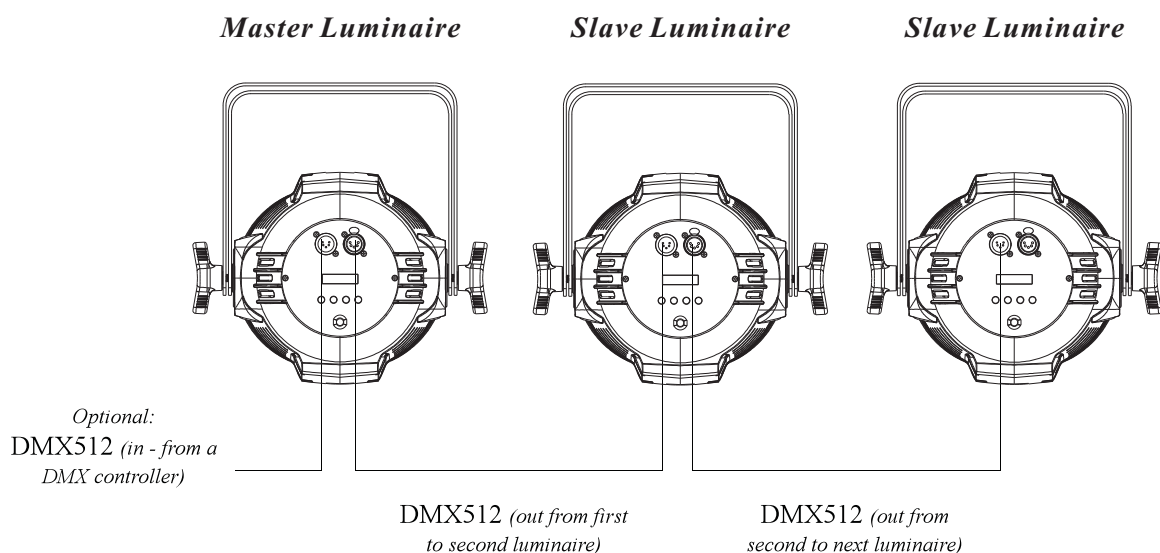

Figure 10: SL eSTROBE 130 LED Luminaire - Master / Slave Configuration

DMX CONTROL

This section contains information for operating the luminaire using DMX control in Single Channel, Three Channel, Four Channel, 16-Bit Control or Zone Mapping modes. For Menu options and detailed information, see the "LCD Display and Menu System" on Page 8.

Note: These tables assume a DMX start address of 1. When a different starting address is used, this address becomes channel 1 function and other functions follow in sequence.

1. SL eSTROBE 130 LED Luminaire DMX Mapping

Single Channel Mode

Table 2 provides DMX channel mapping of all DMX512 control values when the SL eSTROBE 130 LED Luminaire is in Single Channel mode (as set by the luminaire's menu system).

Table 2: SL eSTROBE 130 LED Luminaire DMX Channel Mapping (Single Channel Mode)

DMX Channel	Parameter	Range DMX	Range%	Default- recommended console default values	Description
1	Strobe Rate	0 - 255	0 - 100%	0	Please refer to the Strobe Rate detail.

Three Channel Mode

Table 3 provides DMX channel mapping of all DMX512 control values when the SL eSTROBE 130 LED Luminaire is in Three Channel mode (as set by the luminaire's menu system).

Table 3: SL eSTROBE 130 LED Luminaire DMX Channel Mapping (Three Channel Mode)

DMX Channel	Parameter	Range DMX	Range%	Default- recommended console default values	Description
1	Intensity	0 - 255	0 - 100%	0	8 bit control for Intensity of LED settings
2	Strobe Duration	0 - 255	0 - 100%	0	Strobe's duration, Range is 0-255 White light mode (when strobe rate is also at 255) Please refer to the Strobe Duration Detail
3	Strobe Rate	0 - 255	0 - 100%	0	Strobe rate slow to fast. White light mode (when strobe duration is also at 255) Please refer to the Strobe Rate Detail.

Four Channel Mode

Table 4 provides DMX channel mapping of all DMX512 control values when the SL eSTROBE 130 LED Luminaire is in Four Channel mode (as set by the luminaire's menu system).

Table 4: SL eSTROBE 130 LED Luminaire DMX Channel Mapping (Four Channel Mode)

DMX Channel	Parameter	Range DMX	Range%	Default- recommended console default values	Description
1	Intensity	0 - 255	0 - 100%	0	8 bit control for Intensity of LED settings
2	Strobe Duration	0 - 255	0 - 100%	0	Strobe's duration, Range is 0-255 White light mode (when strobe rate is also at 255) Please refer to the Strobe Duration Detail
3	Strobe Rate	0 - 255	0 - 100%	0	Strobe rate slow to fast. White light mode (when strobe duration is also at 255) Please refer to the Strobe Rate Detail.
4	Effects	0 - 255	0 - 100%	0	Controls strobe operations as follows: No Effect = DMX 0-5 Ramp Up = DMX 6-42 Ramp Down = DMX 43-85 Ramp Up/Down = DMX 86-128 Random = DMX 129-171 Ring 1 = DMX 172-173 Ring 2 = DMX 174-175 Ring 3 = DMX 176-179 Ring 4 = DMX 180-182 Checker pattern A = DMX 183-184 Checker pattern B = DMX 185-186 Random zones = DMX 187-214 Circle zone chase clockwise = DMX 215-235 Circle zone chase counter-clockwise = DMX 236-255

16-Bit Mode

Table 5 provides DMX channel mapping of all DMX512 control values when the SL eSTROBE 130 LED Luminaire is in 16-Bit mode (as set by the luminaire's menu system).

Table 5: SL eSTROBE 130 LED Luminaire DMX Channel Mapping (16-Bit Mode)

DMX Channel	Parameter	Range DMX	Range%	Default- recommended console default values	Description
1 2	Intensity High Intensity Low	0 - 65535	0 - 100%	0	16 bit control for Intensity of LED settings
3	Effects	0 - 255	0 - 100%	DMX 0	Controls strobe operations as follows: No Effect = DMX 0-5 Ramp Up = DMX 6-42 Ramp Down = DMX 43-85 Ramp Up/Down = DMX 86-128 Random = DMX 129-171 Ring 1 = DMX 172-173 Ring 2 = DMX 174-175 Ring 3 = DMX 176-179 Ring 4 = DMX 180-182 Checker pattern A = DMX 183-184 Checker pattern B = DMX 185-186 Random zones = DMX 187-214 Circle zone chase clockwise = DMX 215-235 Circle zone chase counter-clockwise = DMX 236-255
4	Control Channel	0 - 255	0 - 100%	0	Please refer to the Control Channel detail.
5	Strobe Duration	0 - 255	0 - 100%	0	Strobe's duration, Range is 0-255 White light mode (when strobe rate is also at 255) Please refer to the Strobe Duration Detail
6	Strobe Rate	0 - 255	0 - 100%	0	Strobe rate slow to fast. White light mode (when strobe duration is also at 255) Please refer to the Strobe Rate Detail.

Zone Mapping Mode

Table 6 provides DMX channel mapping of all DMX512 control values when the SL eSTROBE 130 LED Luminaire is in Zone Mapping mode (as set by the luminaire's menu system).

Table 6: SL eSTROBE 130 LED Luminaire DMX Channel Mapping (Zone Mapping Mode)

DMX Channel	Parameter	Range DMX	Range%	Default	Description
1 2	Master Intensity - High Master Intensity - Low	0 - 65535	0 - 100%	0	16 bit control for Intensity of LED settings.
3	Effects	0 - 255	0 - 100%	0	Effects.(Refer to the Effects detail)
4	Control Channel	0 - 255	0 - 100%	0	Control Channel(Refer to the Control Channel detail)
5	Zone 1 Intensity	0 - 255	0 - 100%	0	8-bit control for zone Intensity.
6	Zone 1 Strobe Duration	0 - 255	0 - 100%	0	Strobe's duration(Refer to the Strobe Duration Detail.)
7	Zone 1 Strobe Rate	0 - 255	0 - 100%	0	Strobe's rate slow to fast.(Refer to the Strobe Rate detail)
8	Zone 2 Intensity	0 - 255	0 - 100%	0	8-bit control for zone Intensity.
9	Zone 2 Strobe Duration	0 - 255	0 - 100%	0	Strobe's duration(Refer to the Strobe Duration Detail.)
10	Zone 2 Strobe Rate	0 - 255	0 - 100%	0	Strobe's rate slow to fast.(Refer to the Strobe Rate detail)
11	Zone 3 Intensity	0 - 255	0 - 100%	0	8-bit control for zone Intensity.
12	Zone 3 Strobe Duration	0 - 255	0 - 100%	0	Strobe's duration(Refer to the Strobe Duration Detail.)
13	Zone 3 Strobe Rate	0 - 255	0 - 100%	0	Strobe's rate slow to fast.(Refer to the Strobe Rate detail)
14	Zone 4 Intensity	0 - 255	0 - 100%	0	8-bit control for zone Intensity.
15	Zone 4 Strobe Duration	0 - 255	0 - 100%	0	Strobe's duration(Refer to the Strobe Duration Detail.)
16	Zone 4 Strobe Rate	0 - 255	0 - 100%	0	Strobe's rate slow to fast.(Refer to the Strobe Rate detail)

Strobe Rate

Table 7 provides Strobe Rate values of SL eSTROBE 130 LED Luminaire.

Table 7: SL eSTROBE 130 LED Luminaire Strobe Rate

DMX Value	Percent(%)	Frequency(Hz)
0	0	DMX 0-5 – No Flash (single flash with value>5 on intensity one time)
1		
2		
3	1	
4		
5	2	0.500
6		0.500
7		0.504
8	3	0.504
9		0.508
10	4	0.508
11		0.512
12		0.512
13	5	0.517
14		0.517
15	6	0.521
16		0.521
17		0.526
18	7	0.526
19		0.530
20	8	0.530
21		0.535
22		0.535
23	9	0.540
24		0.540
25	10	0.544
26		0.544
27		0.549
28	11	0.549
29		0.554
30		0.554
31	12	0.559
32		0.559
33	13	0.559
34		0.565
35		0.565
36	14	0.570
37		0.570
38	15	0.575
39		0.575
40		0.581
41	16	0.581
42		0.586
43	17	0.586
44		0.586

Table 7: SL eSTROBE 130 LED Luminaire Strobe Rate

DMX Value	Percent(%)	Frequency(Hz)
45		0.592
46	18	0.592
47		0.598
48	19	0.598
49		0.604
50		0.604
51	20	0.610
52		0.610
53		0.616
54	21	0.616
55		0.622
56	22	0.622
57		0.629
58		0.629
59	23	0.635
60		0.635
61	24	0.635
62		0.642
63		0.642
64	25	0.649
65		0.649
66	26	0.656
67		0.656
68		0.663
69	27	0.663
70		0.670
71	28	0.670
72		0.678
73		0.678
74	29	0.685
75		0.685
76	30	0.693
77		0.693
78		0.701
79	31	0.701
80		0.709
81		0.709
82	32	0.717
83		0.717
84	33	0.726
85		0.726
86		0.735
87	34	0.735
88		0.735
89	35	0.744

Table 7: SL eSTROBE 130 LED Luminaire Strobe Rate

DMX Value	Percent(%)	Frequency(Hz)
90		0.744
91		0.753
92	36	0.753
93		0.762
94	37	0.762
95		0.772
96		0.772
97	38	0.782
98		0.782
99	39	0.792
100		0.792
101		0.802
102	40	0.802
103		0.813
104		0.813
105	41	0.824
106		0.824
107	42	0.835
108		0.835
109		0.847
110	43	0.847
111		0.859
112	44	0.859
113		0.871
114		0.663
115	45	0.670
116		0.670
117	46	0.678
118		0.678
119		0.685
120	47	0.685
121		0.693
122	48	0.693
123		0.701
124		0.701
125	49	0.709
126		0.709
127		0.717
128	50	0.717
129		0.726
130	51	0.726
131		0.735
132		0.735
133	52	0.735
134		0.744

Table 7: SL eSTROBE 130 LED Luminaire Strobe Rate

DMX Value	Percent(%)	Frequency(Hz)
135	54	1.016
136		1.033
137		1.033
138	54	1.051
139		1.051
140	55	1.070
141		1.070
142		1.089
143	56	1.089
144		1.089
145	57	1.109
146		1.109
147		1.129
148	58	1.129
149		1.150
150	59	1.150
151		1.173
152		1.173
153	60	1.196
154		1.196
155		1.220
156	61	1.220
157		1.244
158	62	1.244
159		1.270
160		1.270
161	63	1.297
162		1.297
163	64	1.326
164		1.326
165		1.355
166	65	1.355
167		1.386
168	66	1.386
169		1.418
170		1.418
171	67	1.452
172		0.717
173	68	0.717
174		0.726
175		0.726
176	69	0.735
177		0.735
178		0.735
179	70	0.744

Table 7: SL eSTROBE 130 LED Luminaire Strobe Rate

DMX Value	Percent(%)	Frequency(Hz)
180		1.605
181	71	1.605
182		1.648
183		1.648
184	72	1.694
185		1.694
186	73	1.742
187		1.742
188		1.793
189	74	1.793
190		1.848
191	75	1.848
192		1.905
193		1.905
194	76	1.967
195		1.967
196	77	2.033
197		2.033
198		2.103
199	78	2.103
200		2.103
201	79	2.178
202		2.178
203		2.258
204	80	2.258
205		2.345
206	81	2.345
207		2.439
208		2.439
209	82	2.541
210		2.541
211		2.651
212	83	2.651
213		2.772
214	84	2.772
215		2.904
216		2.904
217	85	3.049
218		3.049
219	86	3.209
220		3.209
221		3.388
222	87	3.388
223		3.587
224	88	3.587

Table 7: SL eSTROBE 130 LED Luminaire Strobe Rate

DMX Value	Percent(%)	Frequency(Hz)
225		3.811
226		3.811
227	89	4.065
228		4.065
229		4.065
230	90	4.355
231		4.355
232	91	4.690
233		4.690
234		5.081
235	92	5.081
236		5.543
237	93	5.543
238		6.098
239		6.098
240	94	6.775
241		6.775
242	95	7.622
243		7.622
244		8.711
245	96	8.711
246		10.163
247	97	10.163
248		12.195
249		12.195
250	98	15.244
251		15.244
252	99	20.325
253		20.325
254		30.488
255	100	30.488

Strobe Duration

Table 8 provides Strobe Duration values of SL eSTROBE 130 LED Luminaire.

Table 8: SL eSTROBE 130 LED Luminaire Strobe Duration

DMX Value	Percent (%)	Time(ms)
0	0	0
1		33
2		66
3	1	98
4		131
5	2	164
6		197
7		230
8	3	262
9		295
10	4	328
11		361
12		394
13	5	426
14		459
15	6	492
16		525
17		558
18	7	590
19		623
20	8	656
21		689
22		722
23	9	754
24		787
25	10	820
26		853
27		886
28	11	918
29		951
30		984
31	12	1017
32		1050
33	13	1082
34		1115
35		1148
36	14	1181
37		1214
38	15	1246
39		1279
40		1312
41	16	1345
42		1378
43	17	1410
44		1443
45		1476
46	18	1509
47		1542
48	19	1574
49		1607
50		1640
51	20	1673
52		1706
53		1738
54	21	1771
55		1804

Table 8: SL eSTROBE 130 LED Luminaire Strobe Duration

56	22	1837
57		1870
58		1902
59	23	1935
60		1968
61	24	2001
62		2034
63		2066
64	25	2099
65		2132
66	26	2165
67		2198
68		2230
69	27	2263
70		2296
71	28	2329
72		2362
73		2394
74	29	2427
75		2460
76	30	2493
77		2526
78		2558
79	31	2591
80		2624
81		2657
82	32	2690
83		2722
84	33	2755
85		2788
86		2821
87	34	2854
88		2886
89	35	2919
90		2952
91		2985
92	36	3018
93		3050
94	37	3083
95		3116
96		3149
97	38	3182
98		3214
99	39	3247
100		3280
101		3313
102	40	3346
103		3378
104		3411
105	41	3444
106		3477
107	42	3510
108		3542
109		3575
110	43	3608
111		3641
112	44	3674
113		3706

Table 8: SL eSTROBE 130 LED Luminaire Strobe Duration

114		3739
115	45	3772
116		3805
117	46	3838
118		3870
119		3903
120	47	3936
121		3969
122	48	4002
123		4034
124		4067
125	49	4100
126		4133
127		4166
128	50	4198
129		4231
130	51	4264
131		4297
132		4330
133	52	4362
134		4395
135	53	4428
136		4461
137		4494
138	54	4526
139		4559
140	55	4592
141		4625
142		4658
143	56	4690
144		4723
145	57	4756
146		4789
147		4822
148	58	4854
149		4887
150	59	4920
151		4953
152		4986
153	60	5018
154		5051
155		5084
156	61	5117
157		5150
158	62	5182
159		5215
160		5248
161	63	5281
162		5314
163	64	5346
164		5379
165		5412
166	65	5445
167		5478
168	66	5510
169		5543
170		5576
171	67	5609

Table 8: SL eSTROBE 130 LED Luminaire Strobe Duration

172		5642
173	68	5674
174		5707
175		5740
176	69	5773
177		5806
178		5838
179	70	5871
180		5904
181	71	5937
182		5970
183		6002
184	72	6035
185		6068
186	73	6101
187		6134
188		6166
189	74	6199
190		6232
191	75	6265
192		6298
193		6330
194	76	6363
195		6396
196	77	6429
197		6462
198		6494
199	78	6527
200		6560
201	79	6593
202		6626
203		6658
204	80	6691
205		6724
206	81	6757
207		6790
208		6822
209	82	6855
210		6888
211		6921
212	83	6954
213		6986
214	84	7019
215		7052
216		7085
217	85	7118
218		7150
219	86	7183
220		7216
221		7249
222	87	7282
223		7314
224	88	7347
225		7380
226		7413
227	89	7446
228		7478
229		7511

Table 8: SL eSTROBE 130 LED Luminaire Strobe Duration

230	90	7544
231		7577
232	91	7610
233		7642
234		7675
235	92	7708
236		7741
237	93	7774
238		7806
239		7839
240	94	7872
241		7905
242	95	7938
243		7970
244		8003
245	96	8036
246		8069
247	97	8102
248		8134
249		8167
250	98	8200
251		8233
252	99	8266
253		8298
254		8331
255	100	8364

Note: White light mode (when strobe rate is also at 255)

RDM PARAMETER IDS

1. SL eSTROBE 130 LED Luminaire RDM Parameter IDs

The following tables outline and describe all the RDM parameters IDs associated with SL eSTROBE 130 LED Luminaires.

- Table 9, “SL eSTROBE 130 LED Luminaire RDM Product Parameters IDs”
- Table 10, “SL eSTROBE 130 LED Luminaire RDM UID”
- Table 11, “SL eSTROBE 130 LED Luminaire RDM Parameters IDs”
- Table 12, “SL eSTROBE 130 LED Luminaire RDM Manufacturer Status IDs”, on page 30
- Table 13, “SL eSTROBE 130 LED Luminaire RDM Manufacturer Specific PIDs”, on page 30

Table 9: SL eSTROBE 130 LED Luminaire RDM Product Parameters IDs

Model ID	Manufacturer	Model Description	Product Category
0x2018	Philips Entertainment. Lighting Asia	SL eSTROBE 130	0x0509

Table 10: SL eSTROBE 130 LED Luminaire RDM UID

UID					
MSB of ESTA 50H	LSB of ESTA 41H	MSB of Unique Seq	LSB of Unique Seq	MSB of Unique Seq	LSB of Unique Seq

Table 11: SL eSTROBE 130 LED Luminaire RDM Parameters IDs

Get Allowed	Set Allowed	RDM Parameter IDs	Value	Comment	Impemented
<i>Category - Network Managment</i>					
		DISC_UNIQUE_BRANCH	0x0001		●
		DISC_MUTE	0x0002		●
		DISC_UN_MUTE	0x0003		●
●		PROXIED_DEVICES	0x0010		
●		PROXIED_DEVICES_COUNT	0x0011		
●	●	COMMS_STATUS	0x0015		
<i>Category - Status Collection</i>					
●		QUEUED_MESSAGE	0x0020		●
●		STATUS_MESSAGES	0x0030		●
●		STATUS_ID_DESCRIPTION	0x0031		●
	●	CLEAR_STATUS_ID	0x0032		●
●	●	SUB_DEVICE_STATUS_REPORT_THRESHOLD	0x0033		
<i>Category - RDM Information</i>					
●		SUPPORTED_PARAMETERS	0x0050	Support required only if supporting Parameters beyond the minimum required set.	●
●		PARAMETER_DESCRIPTION	0x0051	Support required for Manufacturer-Specific PIDs exposed in SUPPORTED_PARAMETERS message.	●

Table 11: SL eSTROBE 130 LED Luminaire RDM Parameters IDs

Get Allowed	Set Allowed	RDM Parameter IDs	Value	Comment	Impemented
Category - Product Information					
●		DEVICE_INFO	0x0060		●
●		PRODUCT_DETAIL_ID-LIST	0x0070		
●		DEVICE_MODEL_DESCRIPTION	0x0080		●
●		MANUFACTURER_LABEL	0x0081		●
●	●	DEVICE_LABEL	0x0082		●
●	●	FACTORY_DEFAULT	0x0090		●
●		LANGUAGE_CAPABILITIES	0x00A0		
●	●	LANGUAGE	0x00B0		
●		SOFTWARE_VERSION_LABLE	0x00C0		●
●		BOOT_SOFTWARE_VERSION_ID	0x00C1		
●		BOOT_SOFTWARE_VERSION_LABEL	0x00C2		
Category - DMX512 Setup					
●	●	DMX_PERSONALITY	0x00E0		●
●		DMX_PERSONALITY_DESCRIPTION	0x00E1		●
●	●	DMX_START_ADDRESS	0x00F0	<i>Required if device uses a DMX Slot</i>	●
●		SLOT_INFO	0x0120		●
●		SLOT_DESCRIPTION	0x0121		●
●		DEFAULT_SLOT_VALUE	0x0122		
Category - Sensors 0x02xx					
●		SENSOR_DEFINITION	0x0200		●
●	●	SENSOR_VALUE	0x0201		●
	●	RECORD SENSORS	0x0202		
Category - Dimmer Settings 0x03xx - FUTURE USE					
Category - Power / Lamp Settings 0x04xx					
●	●	DEVICE_HOURS	0x0400		
●	●	LAMP_HOURS	0x0401		
●	●	LAMP_STRIKES	0x0402		
●	●	LAMP_STATE	0x0403		
●	●	LAMP_N_MODE	0x0404		
●	●	DEVICE_POWER_CYCLES	0x0405		
Category - Display Settings 0x05xx					
●	●	DISPLAY_INVERT	0x0500		
●	●	DISPLAY_LEVEL	0x0501		
Category - Configuration 0x06xx					
●	●	PAN_INVERT	0x0600		
●	●	TILT_INVERT	0x0601		
●	●	PAN_TILT_SWAP	0x0602		
●	●	REAL_TIME_CLOCK	0x0603		
Category - Control 0x10xx					
●	●	IDENTIFY_DEVICE	0x1000		●
	●	RESET_DEVICE	0x1001		

Table 11: SL eSTROBE 130 LED Luminaire RDM Parameters IDs

Get Allowed	Set Allowed	RDM Parameter IDs	Value	Comment	Implemented
■	■	POWER_STATE	0x1010		
■	■	PERFORM_SELFTEST	0x1020		
■		SELF_TEST_DESCRIPTION	0x1021		
	■	CAPTURE_PRESET	0x1030		
■	■	PRESET_PLAYBACK	0x1031		

Table 12: SL eSTROBE 130 LED Luminaire RDM Manufacturer Status IDs

<p>Manufacturer Specific messages are in the range of 0x8000 - 0xFFDF. Each Manufacturer-specific Status ID shall have a unique meaning, which shall be consistent across all products having a given Manufacturer ID. See Table B-2, ANSI E1.20-2010.</p>				
Status ID Message	Value	Data Value 1	Data Value 2	Status ID Description
8100H		00H	00H	ALL OK

Table 13: SL eSTROBE 130 LED Luminaire RDM Manufacturer Specific PIDs

Get Allowed	Set Allowed	RDM Parameter IDs	Type	Length	Unit	Prefix	Min	Max	Default	Description
<i>Category - Manufacturer Defined PIDs - Range is 0x8000-0xffdf (See ANSI E1.20-2010 Standard, Table A-3)</i>										
■	■	8A00H	U8	1	None	None	0	100	100	DIMMER
■	■	8AB2H	U8	1	None	None	1	18	1	Chase
■	■	8AB1H	U8	1	None	None	0	31	0	Preset
■	■	8A92H	U8	1	None	None	0	255	0	Strobe
■	■	8A94H	U8	1	None	None	0	85	0	Duration
■	■	8A40H	U8	1	None	None	0	1	0	Link Mode
■	■	8AA1H	U8	1	None	None	0	3	0	Dimming Curve
■	■	8A0CH	U8	1	None	None	0	3	0	DMX FAIL MODE
■	■	8AA0H	U8	1	None	None	0	4	0	Backlight Off Time
■	■	8AA2H	U8	1	None	None	0	50	0	Power Up Setup
■	■	8A97H	U8	1	None	None	0	1	0	Fan AUTO / OFF Setup
■	■	8A98H	U8	1	None	None	0	255	0	Effect

CLEANING AND CARE



WARNING! All cleaning should be performed with power completely removed from the luminaire. Never remove protective covers when the luminaire is powered. Wear appropriate protective eye wear and gloves when cleaning the luminaire. All service and maintenance, other than described herein, should be performed by a qualified technician or Authorized Service Center.

1. Special Cleaning and Care Instructions

Being a solid-state luminaire, and unlike most luminaires, the SL eSTROBE 130 LED Luminaire requires very little routine maintenance by the user. This section covers portions of the luminaire that can be removed for cleaning.

The SL eSTROBE 130 LED Luminaire requires special care when it comes to cleaning the front lens assembly. Additional care needs to be taken with the plastic components because they are much easier to scratch or damage than the glass lenses used in traditional luminaires.

The following is a list of cleaning materials required to care for your SL eSTROBE 130 LED Luminaire:

- Lint free lens tissue
- Lint or powder free gloves
- Reagent grade isopropyl alcohol*
- A mild soap solution.

Note: *Reagent grade isopropyl alcohol is good to use on the SL eSTROBE 130 LED Luminaire plastic optics with anti-reflection coatings.

If the lens is still dirty after using isopropyl alcohol, for instance if fingerprints or oil is just redistributed and not cleaned off the optic, then a mild soap and water solution can be used to gently wash the lens, Repeat the cleaning with isopropyl alcohol to eliminate streaks and soap residue.



WARNING! Under no circumstances should ammonia-based cleaners, acetone, or other harsh solvents be used on or near the SL eSTROBE 130 LED Luminaire. These types of cleaners or solvents can permanently damage the optics or housing of the luminaire.

If you have any questions regarding the use or care of your SL eSTROBE 130 LED Luminaire, please contact Showline technical support or your local Authorized Dealer.

2. Front Lens Cleaning

To clean the front lens:

- Step 1. Turn off the luminaire and allow to cool completely.
- Step 2. Apply a small amount of reagent grade isopropyl alcohol to lint-free lens tissue.
- Step 3. Wipe all debris, dirt, fingerprints, etc. from lens.
- Step 4. Using a second lint-free lens tissue, wipe off any alcohol residue.

3. Service and Maintenance

For all other service and maintenance issues, please contact your local Showline office or an Authorized Service Centre.



WARNING! Disassembly (other than as described herein), alterations, unauthorized service, etc. will void the product warranty. Contact your local Showline office or an Authorized Service Center for technical support and service.

4. Accessories

Only Showline approved accessories should be used with your SL eSTROBE 130 LED Luminaire. For a list of available accessories from Showline, please see [“Accessories” on page 3](#). For questions regarding accessories, please contact your local Authorized Showline Dealer or Showline office.

TECHNICAL SPECIFICATIONS

1. Operational Specifications

Source:	Cool White Array
Beam Angle:	120 Degrees
Light Output:	>26,000 lumens
Color Temperature:	6500K
Input Voltage(AC):	100V to 240V (+/- 10%, auto-ranging)
Current(AC):	1.30 Amps (100V) / 0.54Amps(240V)
Power Consumption:	130 Watts(max)
Frequency:	50/60Hz
Control Protocols:	DMX512(1990) / DMX512A(RDM) / On-Board Menu
Ambient Temperature:	1 to 40 Degrees C (33 to 104 Degrees F)
Humidity:	35~85 RH%
Cooling:	Forced Air
Housing:	Die Cast Aluminium with Powder Coating
Weight:	8.8 lbs(4 kg) - Luminaire only (no accessories)
Compliance:	CE Marked
IP Rating:	IP20

Note: Common model specifications shown. For specific model specifications, features, and accessories, refer to the product specification sheet for more details.



2. Luminaire Dimensions

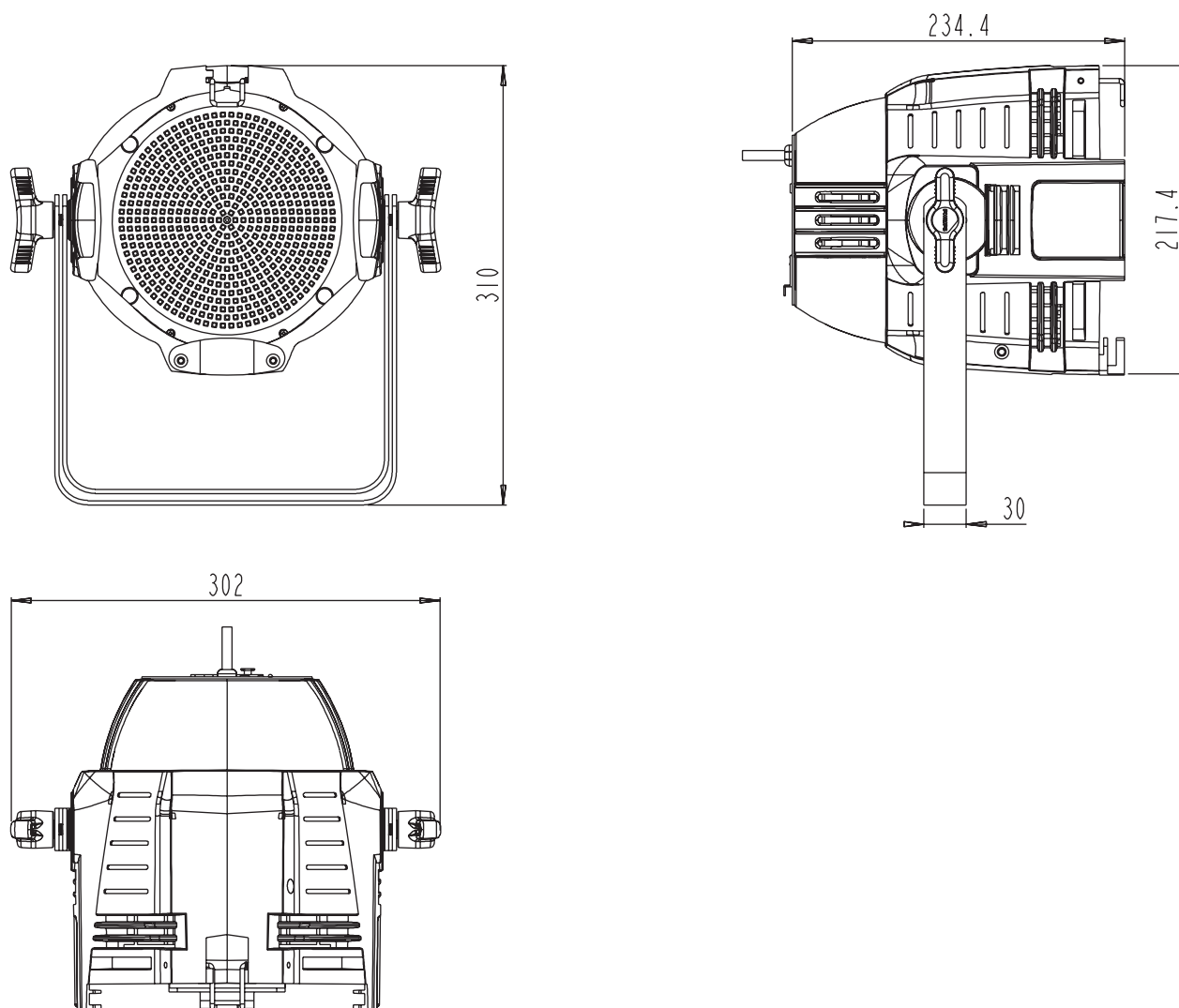

NOTE

Showline

Dallas

10911 Petal Street
Dalls, TX 75238
Tel: +1 214-647-7880
Fax: +1214-647-8031

Asia

Unit C, 14/F, Roxy Industrial Centre
No. 41-49 Kwai Cheong Road
Kwai Chung, N.T., Hong Kong
Tel: +852 2796 9786
Fax: +852 2798 6545

Auckland

19-21 Kawana Street
Northcote, Auckland 0627
New Zealand
Tel: +64 9 481 0100
Fax: +64 9 481 0101

Europe

Rondweg zuid 85
Winterswijk 7012 JD
The Netherlands
Tel: +31 (0) 543-542516