

# Led Blinder 148<sup>LT</sup>

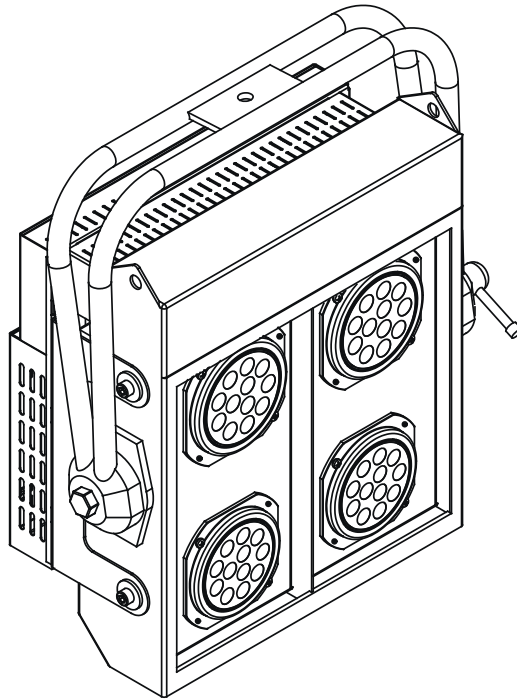

**LED** TECHNOLOGY

**USER MANUAL**



# Led Blinder 148 LT

## Table of contents

|  |           |
|--|-----------|
| <b>1. Safety instructions</b> .....                          | <b>4</b>  |
| <b>2. Operating determinations</b> .....                     | <b>4</b>  |
| <b>3. Description of the LedBlinder 148 LT</b> .....         | <b>5</b>  |
| <b>4. Installation</b> .....                                 | <b>5</b>  |
| 4.1. Connection to the mains .....                           | 5         |
| 4.2 DMX-512 connection/connection between fixtures .....     | 6         |
| 4.3 Rigging the fixture .....                                | 6         |
| 4.4 Fitting the frost filter.....                            | 7         |
| <b>5. Led Blinder 148 LT-DMX protocol ,version 1.1</b> ..... | <b>8</b>  |
| <b>6. Led Blinder 148 LT- Control menu map</b> .....         | <b>10</b> |
| <b>7. Control board</b> .....                                | <b>11</b> |
| 7.1 Addressing the LedBlinder 148 LT .....                   | 11        |
| 7.2 Program running .....                                    | 11        |
| 7.3 Manual mode .....  | 12        |
| 7.4 Test sequences .....                                     | 13        |
| 7.5 Stand-alone mode.....                                    | 13        |
| 7.6 Special functions .....                                  | 13        |
| <b>8. Technical Specifications:</b> .....                    | <b>15</b> |
| <b>9. Maintenance</b> .....                                  | <b>16</b> |

**CAUTION!**  
***Unplug mains lead before opening the housing!***

**FOR YOUR OWN SAFETY, PLEASE READ THIS USER MANUAL CAREFULLY  
BEFORE YOU INITIAL START - UP!**

## 1. Safety instructions

Every person involved with installation and maintenance of this product has to:

- be qualified
- follow the instructions of this manual

**CAUTION!**  
***Be careful with your operations. With a high voltage you can suffer  
a dangerous electric shock when touching the wires inside the unit!***

This product has left our premises in absolutely perfect condition. In order to maintain this condition and to ensure a safe operation, it is absolutely necessary for the user to follow the safety instructions and warning notes written in this manual.

### **Important:**

The manufacturer will not accept liability for any resulting damages caused by the non-observance of this manual or any unauthorized modification to the product.

Always ground the unit.

The electric connection, repairs and servicing must be carried out by a qualified employee.

Do not connect this unit to a dimmer pack.

Use a source of AC power that complies with local building and electrical rules. AC power has to have both overload and short circuit protection.

**CAUTION!**  
**Avoid looking directly into the LED light beam at close range!**

## 2. Operating determinations

This product was designed for indoor use only.

If the unit has been exposed to drastic temperature fluctuation (e.g. after transportation), do not switch it on immediately. The arising condensation water might damage your unit. Leave the unit switched off until it has reached room temperature.

Avoid brute force when installing or operating the unit.

When choosing the installation-spot, please make sure that the unit is not exposed to extreme heat, moisture or dust.

Only operate the unit after having checked that the housing is firmly closed and all screws are tightly fastened.

The maximum ambient temperature 40° C must never be exceeded.

Operate the unit only after having familiarized with its functions. Do not permit operation by persons not qualified for operating the unit. Most damages are the result of unprofessional operation!

Please use the original packaging if the product is to be transported.

Please consider that unauthorized modifications on the unit are forbidden due to safety reasons!

### 3. Description of the LedBlinder 148 LT

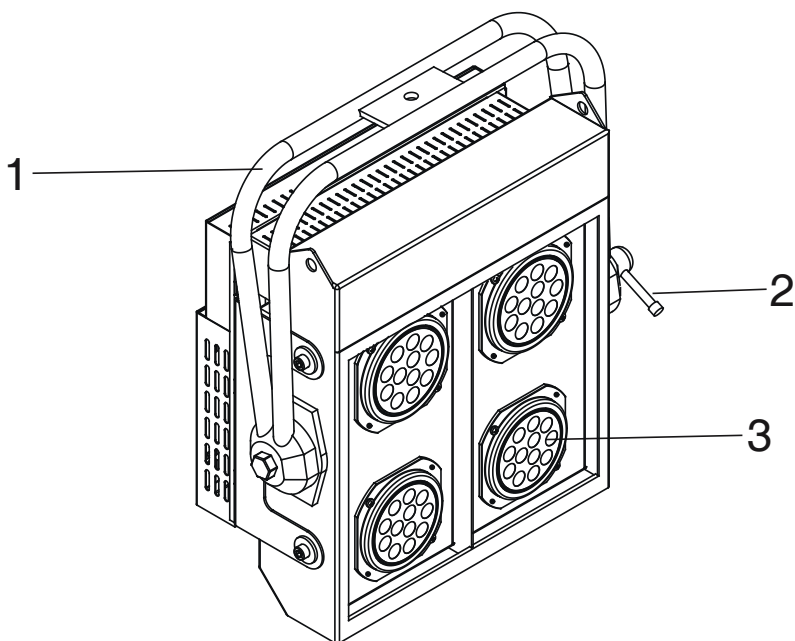

- 1 - Mounting yoke
- 2 - "T" bar
- 3 - LED modules

#### Control board

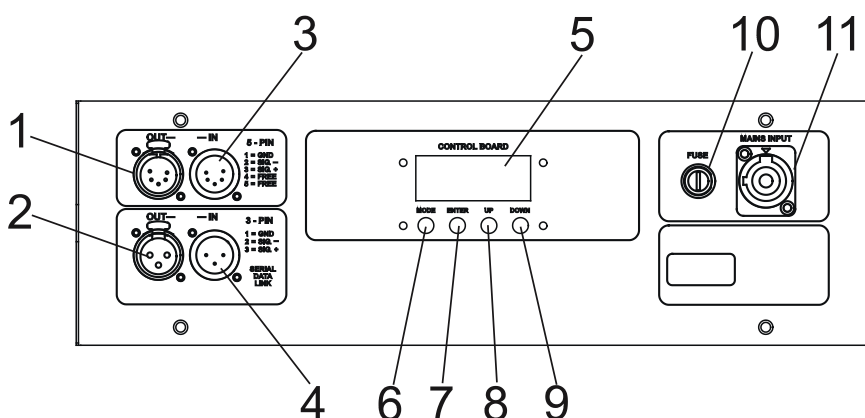

- 1 - 5-pin DMX output
- 2 - 3-pin DMX output
- 3 - 5-pin DMX input
- 4 - 3-pin DMX input
- 5 - LED display
- 6 - Mode-button
- 7 - Enter-button
- 8 - Up-button
- 9 - Down-button
- 10 - Fuse holder
- 11 - Mains input

### 4. Installation

#### 4.1. Connection to the mains

The LedBlinder 148 is equipped with auto-switching power supply that automatically adjusts to any 50/60 Hz AC power source from 100-240 volts.

Connect the LedBlinder 148 to the mains with the power cord.

If the plug on the flexible cord is not the right type for your socket outlets, do not use an adaptor, but remove the plug from the cord and discard. Carefully prepare the end of the supply cord and fit a suitable plug.

The earth has to be connected!

Cord plug connections:

| Cable (EU)   | Cable (US) | Pin     | International |
|--------------|------------|---------|---------------|
| Brown        | Black      | Live    | L             |
| Light blue   | White      | Neutral | N             |
| Yellow/Green | Green      | Earth   |               |

## 4.2 DMX-512 connection/connection between fixtures

The fixture is equipped with both 3-pin and 5-pin XLR sockets for DMX input and output. The sockets are wired in parallel.

Only use a shielded twisted-pair cable designed for RS-485 and 3-pin or 5-pin XLR-plugs and connectors in order to connect the controller with the fixture or one fixture with another.

### DMX - output

XLR mounting-sockets (rear view):

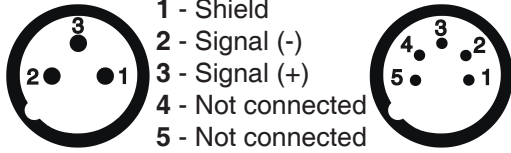

### DMX-input

XLR mounting-plugs (rear view):

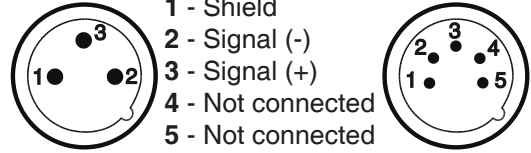

If you are using the standard DMX controllers, you can connect the DMX output of the controller directly with the DMX input of the first fixture in the DMX-chain. If you wish to connect DMX-controllers with other XLR-out-puts, you need to use adapter-cables.

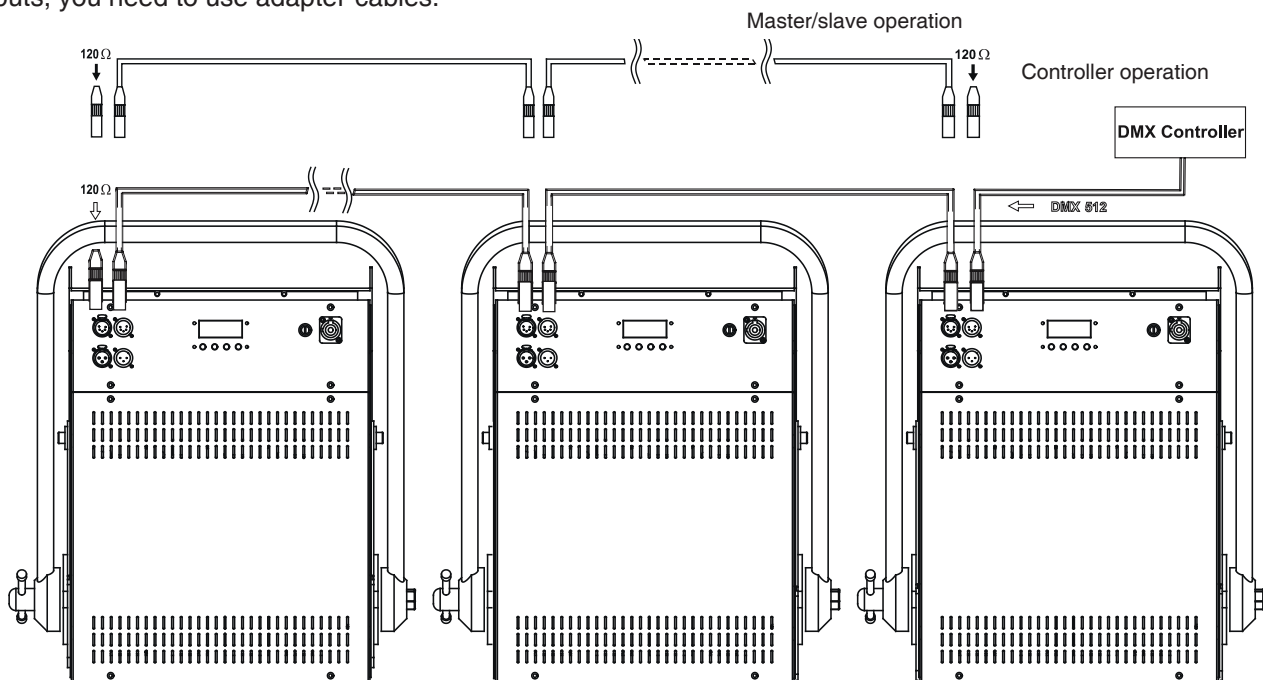

### Building a serial DMX-chain:

Connect the DMX-output of the first fixture in the DMX-chain with the DMX-input of the next fixture. Always connect one output with the input of the next fixture until all fixtures are connected.

**Caution:** At the last fixture, the DMX-cable has to be terminated with a terminator. Solder a 120  $\Omega$  resistor between Signal (-) and Signal (+) into a 3-pin XLR-plug and plug it in the DMX-output of the last fixture.

### Building a master/slave-chain:

Connect the DMX-output of the master fixture in the data-chain with the DMX-input of the first slave. Always connect output with the input of the next slave until all slaves are connected (up to 9 fixtures).

**Caution:** It's necessary to insert the XLR termination plug (with 120 Ohm) into the input of the master fixture and into the output of the last slave fixture in the link in order to ensure proper transmission on the data link.

## 4.3 Rigging the fixture

**Please consider the respective national norms during the installation!**

The fixture should be hung on a truss structure using a mounting clamp (not included). Mounting yoke has a 13 mm diameter hole for fixing the mounting clamp. The fixture can be tilted + - 180°. The required tilt angle of the fixture can be adjusted by means of the "T" bar on the side of the fixture.

The installation must always be secured with a secondary safety attachment, e.g. an appropriate cord .Fasten the safety cord through the mounting yoke and over the trussing system.

When rigging, derigging or servicing the fixture staying in the area below the installation place, on bridges, under high working places and other endangered areas is forbidden.

The operator has to make sure that safety-relating and machine-technical installations are approved by an expert before taking into operation for the first time and after changes before taking into operation another time.

The operator has to make sure that safety-relating and machine-technical installations are approved by a skilled person once a year.

The fixture should be installed outside areas where persons may walk by or be seated.

**IMPORTANT! OVERHEAD RIGGING REQUIRES EXTENSIVE EXPERIENCE**, including calculating working load limits, installation material being used, and periodic safety inspection of all installation material and the projector. If you lack these qualifications, do not attempt the installation yourself, but instead use a professional structural rigger. Improper installation can result in bodily injury and/or damage to property.

If the fixture shall be lowered from the ceiling or high joists, professional trussing systems have to be used. The fixture must never be fixed swinging freely in the room.

**Caution:** Fixtures may cause severe injuries when crashing down! If you have doubts concerning the safety of a possible installation, do not install the fixture!

Before rigging make sure that the installation area can hold a minimum point load of 10 times the fixture's weight.

**Danger of fire !**  
**When installing the device, make sure there is no highly inflammable material in a distance of min. 0.5m.**

**CAUTION!**  
**Make sure that the device is fixed properly! Ensure that the structure (truss)to which you are attaching the fixtures is secure.**  
**Instal the device in a ventilated location.Never cover air vents!**

#### 4.4 Fitting the frost filtr

The LedBlinder 148 is supplied with clear glasses covering LED modules. If you wish to use a diffusive light , it is possible to order glass or film frost filter sets and fix them on the LED modules by two fastenig screws.

Glass filters- soft frost light

Film filters-dense frost light

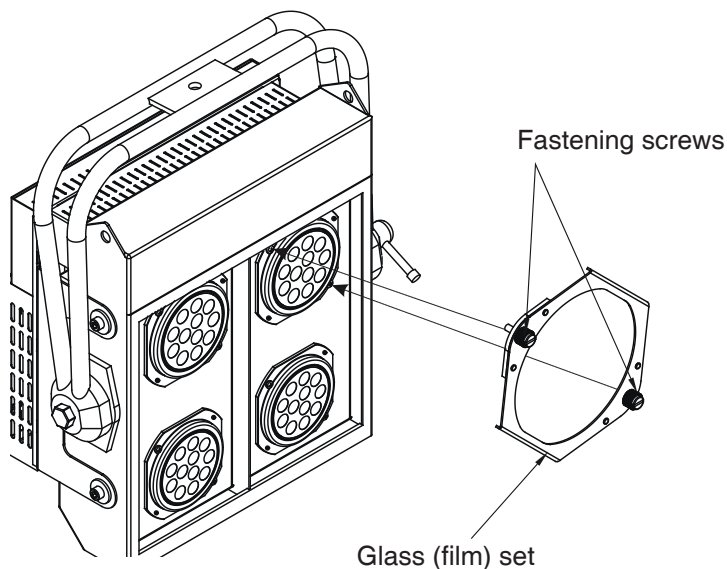





|   |         |              |         |   |              |
|---|---------|--------------|---------|---|--------------|
| 8 | 5       |              | 0-31    | <b>SHUTTER/STROBE</b><br>Shutter closed           | step         |
|   |         |              | 32-63   | Shutter open                                      | step         |
|   |         |              | 64-95   | Strobe-effect from slow to fast                   | proportional |
|   |         |              | 96-127  | Shutter open                                      | step         |
|   |         |              | 128-143 | Opening pulses in sequences from slow to fast     | proportional |
|   |         |              | 144-159 | Closing pulses in sequences from fast to slow     | proportional |
|   |         |              | 160-191 | Shutter open                                      | step         |
|   |         |              | 192-223 | Random strobe-effects from slow to fast           | proportional |
|   | 224-255 | Shutter open | step    |   |              |
| 9 | 6       |              | 0-255   | <b>DIMMER</b><br>Dimmer intensity from 0% to 100% | proportional |

**Zone positions:**  
(every zone contains two LED modules)

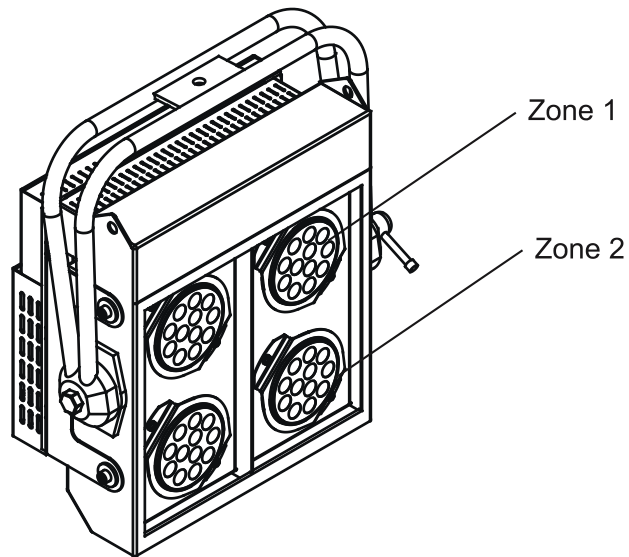

## 6.Led Blinder 148 LT - Control menu map

Default settings=**Bold print**

**A001** (001-504)

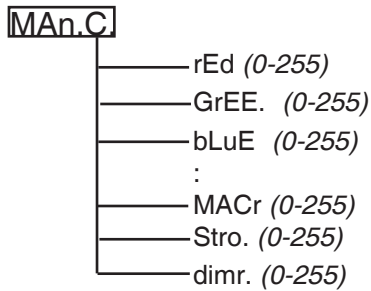
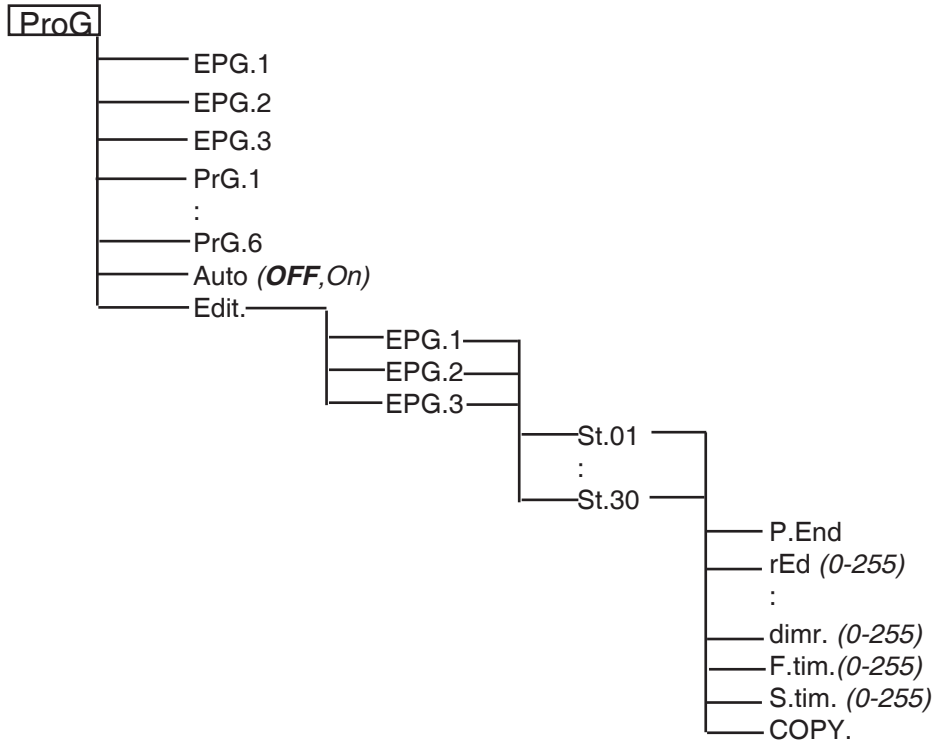

**tEst**

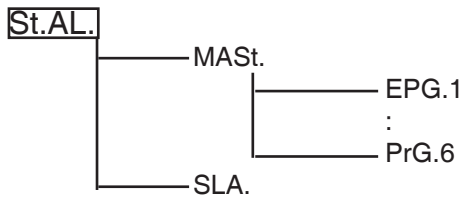

**SPEC.**

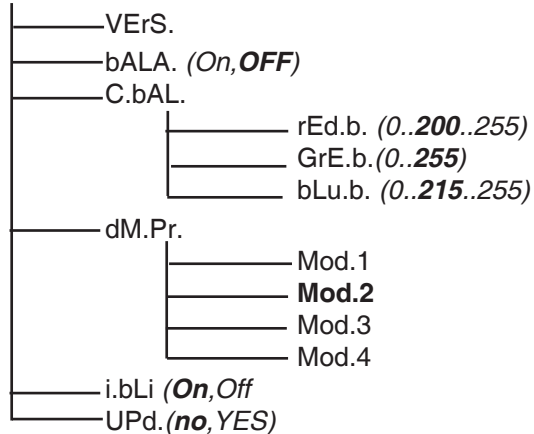

## 7. Control board

The control panel situated on the top cover of the LedBlinder 148 allows DMX addressing, calling build-in programs and setting the fixture behaviour.

### Control elements on the control board:

[MODE] button-leaves menu without saving changes.

[ENTER] button- enters menu, confirms adjusted values and leaves menu.

[UP] button and [DOWN] button- moves between menu items on the the same level, sets values.

After switching the fixture on, the display shows the initial screen:



Use [UP],[DOWN] to browse through the menu. To select a function or submenu, press [ENTER].

### 7.1 Addressing the LedBlinder 148 LT



The fixture can be operated in the two modes: **DMX mode**-fixture is controlled via DMX 512 by an external DMX controller

**Stand-alone mode** - fixture uses build-in programs and is able to control other fixtures in the master/slave chain.

See the chapter "Stand-alone mode" for detail description.

For DMX mode is important the DMX start address that is defined as the first channel from which the LedBlinder 148 will respond to the DMX controller.

#### Setting the DMX start channel for DMX operating:

1. Connect LedBlinder 148 to the mains.
2. Browse through the menu by pressing the [UP] and [DOWN] buttons until the display shows current address "A001". Confirm by pressing [ENTER] button and "A001" will start to flash frequently.
3. Use the [UP] and [Down] buttons to select the desired address.
4. Confirm by pressing [ENTER]. After having addressed LedBlinder 148, you may now start operating LedBlinder 148 via your DMX controller.

### 7.2 Program running



By enter to this menu a complete overview of all programs is offered, from which the program to be run can be selected by pressing [ENTER] button. Selected program runs in a loop. The fixture includes 6 built-in programs (PrG.1-PrG.6) and 3 free editable programs (EPG.1-EPG.3), each up to 30 steps. Each program step has a fade time-the time during which effects go to the current step and a Standing time-the time, during which effects last in the current step.

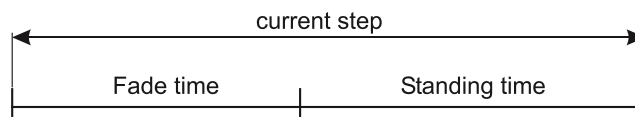

Programming procedure:

1. Enter "Edit." menu
2. Press [UP] or [DOWN] to select the desired program which you wish to edit and press [ENTER].
3. Press [UP] or [DOWN] to select the desired program step ("St.01" - "St.30") and press [ENTER].
4. Press [UP] or [DOWN] to select the desired item and press [ENTER]-button. Now you can edit by using [UP] or [DOWN] buttons the DMX values of selected item:

**P.End.** - a total number of the program steps (value 1-30). This value you must set before start programming (e.g. if you want to create program with 10 steps, set

P.End=10).

**rEd.1** - a red LEDs 1 saturation, value 0-255  
**GrE.1** - a green LEDs 1 saturation, value 0-255  
**bLu.1** - a blue LEDs 1 saturation, value 0-255

**rEd.2** - a red LEDs 2 saturation, value 0-255  
**GrE.2** - a green LEDs 2 saturation, value 0-255  
**bLu.2** - a blue LEDs 2 saturation, value 0-255

Following item are common for all zones:

- MACr.** - a macro selection,value 0-255
- Stro.** - a strobe,value 0-255
- dimr.** - a dimmer,value 0-255
- F.tim.** - fade time,value 0-255 \*
- S.tim.** - standing time,value 0-255 \*
- COP.** - copying the current prog. step to the next prog. step.

Press [ENTER]-button to confirm adjusted value .

5.Repeat steps 3 and 4 for next prog.step.If you want to copy current prog. step to the next prog.step, select option "COPY."and confirm it by pressing [ENTER].

\*Both Fade time and Standing time use the same conversion table in order to convert DMX value to the time value:

| DMX | Time [sec.] | DMX | Time [min.] | DMX | Time [min.] | DMX | Time [min.] | DMX | Time [min.] |
|-----|-------------|-----|-------------|-----|-------------|-----|-------------|-----|-------------|
| 1   | 0.1         | 50  | 4.2         | 105 | 18.4        | 160 | 42.7        | 215 | 77          |
| 2   | 0.4         | 55  | 5           | 110 | 20.2        | 165 | 45.4        | 220 | 80.7        |
| 5   | 2.5         | 60  | 6           | 115 | 22          | 170 | 48.2        | 225 | 84.4        |
| 10  | 10          | 65  | 7           | 120 | 24          | 175 | 51          | 230 | 88.2        |
| 15  | 22.5        | 70  | 8.2         | 125 | 26          | 180 | 54          | 235 | 92          |
| 20  | 40          | 75  | 9.4         | 130 | 28.2        | 185 | 57          | 240 | 96          |
| 25  | 62.5        | 80  | 10.7        | 135 | 30.4        | 190 | 60.2        | 245 | 100         |
| 30  | 90          | 85  | 12          | 140 | 32.7        | 195 | 63.4        | 250 | 104         |
| 35  | 122.5       | 90  | 13.5        | 145 | 35          | 200 | 66.7        | 255 | 108         |
| 40  | 160         | 95  | 15          | 150 | 37.5        | 205 | 70          |     |             |
| 45  | 202.5       | 100 | 16.7        | 155 | 40          | 210 | 73.5        |     |             |

Exact expression of the time value follows the formula: time[sec.]=(DMX value)<sup>2</sup>/10.

If Item "Auto" is on,the fixture in DMX mode remembers last running program and this program will run after switching on the fixture.

## 7.3 Manual mode



This menu gives access to the control of the fixture channels by means of the control buttons.

Use [UP] and [DOWN] buttons until the display shows "MAN.C." menu.Press [ENTER] button and by using [UP] and [DOWN] buttons select desired effect,press [ENTER] and and by using [UP] and [DOWN] buttons adjust desired DMX value for selected effect.Confirm by [ENTER].

- rEd** - all red LEDs saturation,value 0-255
- GrEE.** - all green LEDs saturation,value 0-255
- bLuE** - all blue LEDs saturation,value 0-255
- rEd.1** - a red LEDs 1 saturation,value 0-255
- GrE.1** - a green LEDs 1 saturation,value 0-255
- bLu.1** - a blue LEDs 1 saturation,value 0-255
- rEd.2** - a red LEDs 2 saturation,value 0-255
- GrE.2** - a green LEDs 2 saturation,value 0-255
- bLu.2** - a blue LEDs 2 saturation,value 0-255
- MACr.** - a macro selection,value 0-255
- Stro.** - a strobe,value 0-255
- dimr.** - a dimmer,value 0-255

## 7.4 Test sequences



Use the item to run a special demo-test sequences without an external controller,which will show you some possibilities of using the fixture.

## 7.5 Stand-alone mode

**SLA.**

Synchronous operation of multiple fixtures requires that they must be connected on a data link and one of them is set as a master ("MASt.") and the rest as the slaves ("SLA."). Only one fixture can be set as the master. The slaves mimic the behavior of the master. Effect actions are triggered by an internal timer of the master fixture.

**Important!:** Disconnect the fixtures from the DMX controller before master/slave operating, otherwise data collisions can occur and the fixtures will not work properly!

**MASt. --- Master.** Enter this menu if you want to set the the fixture as a master. Use [UP] and [DOWN] buttons to select desired program and press [ENTER] to confirm selection.

**SLA. --- Slave.** Enter this menu if you want to set the the fixture as a slave.

The master fixture starts simultaneous program start in the other slave fixtures. All fixtures are synchronized in every prog.steps. The fixtures run their programs repeatedly (e.g. if master runs its program "PrG.5", all slaves will be executed program "PrG.5" too).

## 7.6 Special functions

**SPEC.**

Use this menu for special services.

**VERs. --- Software Version.** Select this function to read the number of the fixture software.

**bALA. --- Balance.** Select this function to enable (On) or disable (OFF) the white balance which is set in "White colour balance" menu below. If this function is set OFF, LedBlinder 148 will use maximum values (255) of saturation for red, green and blue channel.

**C.bAL. --- White colour balance.** Using this menu you can set white balance:

1. Browse through the menu by pressing the [UP] and [DOWN] buttons until the display shows "C.bAL." menu. Press [ENTER] button and "rEd.b." will appear on the display.
2. Press [ENTER] button again and use [UP] and [DOWN] buttons to adjust the new maximum value required for the red channel. Confirm your choice by pressing [ENTER]. Use the [UP] and [Down] buttons to select next colour.
3. Repeat step 2 for green channel "GrE.b." and for blue channel "bLu.b."

**dM.Pr. --- DMX presetting.** The function makes possible to select from the 4 DMX- channels settings. Use [UP] and [DOWN] buttons to select desired channel modes ("Mod.1, Mod.2, Mod.3, Mod.4") and press [ENTER] to confirm. For detail description of all channels see DMX protocol.

**i.bLi. --- Initial blink.** If this function is on, Led Blinder 148 makes auto-calibration (All LEDs light on 100% for a short time) after switching it on. If this function is set off, you have to set manually every colour on max. brightness after switching on the driver before starting regular operating. This action should last min. one second.

**UPd. --- Software update** - Using this function you can update software in the fixture via PC and serial link.

The following are required in order to update software:

- PC running Windows 95/98/2000/XP or Linux
- DMX Software Uploader
- Flash cable RS232/DMX (No.13050624)

**Note1:** Software update should execute a qualified person. If you lack qualification, do not attempt the update yourself and ask for help your ROBE distributor.

**Note 2:** DMX address, programs and all settings will be set to their default values

**To update software in the fixture:**

1. Installation of DMX Software Uploader:
  1. DMX Software Uploader program is available from the ROBE web site at [WWW.robe.cz](http://WWW.robe.cz).
  2. Make a new directory ( e.g. Robe\_Uploader) on your hard disk and download the software to it.

**3.**Unpack the program from the archive. Program file has name:DSU\_name of corresponding fixture\_SoftwareID.SoftwareID describes the versions of fixture software included in DMX Software Uploader. Higher number means later software versions.

**2.**Fixture software updating:

**1.**Determine which of your COM port is available on your PC and connect it with to the DMX input of the fixture using the Flash cable. Do not extend this cable! Disconnect the fixture from the other fixtures in DMX chain! Turn on the computer and the fixture.

**2.**Switch the fixture to the update mode by selecting the option Software update in menu Special Functions on the fixture control panel:SPEC-->UPd-->yES.(From this option you cannot return back to the main menu. If you do not want to continue in software update, you have to switch off and on the fixture to leave this option!)

**3.**It is recommended that you exit all programs before running the Software Uploader.

**4.**Start the Software Uploader program. Select desired COM and then click Connect button.

If the connection is OK, click Start Uploading button to start uploading. It will take several minutes to perform software update.All processors will be updated (including processors with the same software version).

If you wish to update only later versions of processors, enable the Incremental Update check box. Avoid interrupting the process. Update status is being displayed in the list window.

When the update is finished, the line with the text "The fixture is successfully updated" will appear in this window and the fixture will reset with the new software.

Note: In the case of interruption of the upload process (e.g. power cut), the fixture remains in the update mode and you have to repeat the software update again.

For example: The fixture was switched off before finishing software upload. After switching the fixture on again, the fixture is still in the update mode and the display is dark. Restart the Software Uploader program and repeat software update from your PC.

## Technical Specifications

### Power supply:

Input Voltage:100-240 V AC, 50/60 Hz

Fuse:T 2 A

Max.Pover Consumption:70VA

### Input:

Control:DMX 512

DMX connection: 3-pin or 5-pin XLR-sockets

### DMX channels:

4 protocol modes,3-9 channels

### LED beam angle:

Each LED has 25° beam angle

### Control and programming:

Protocol: USITT DMX-512

Control options:DMX,Auto-trigger

Operation modes:Master/Slave,Stand alone

Programs:6 build-in programs+3 user editable programs up to 30 steps each

Display:4 digit LED

White colour balance adjusting

Manual control of all DMX channels with LED control panel

2 pairs of 12 LEDs modules

### Temperatures

Maximum ambient temperature : 40° C

Maximum housing temperature : 60° C

### Minimum distances

Min.distance from ammable surfaces: 0,5m

Min.distance to lighted object: 1.3 m

### Dimensions(mm):

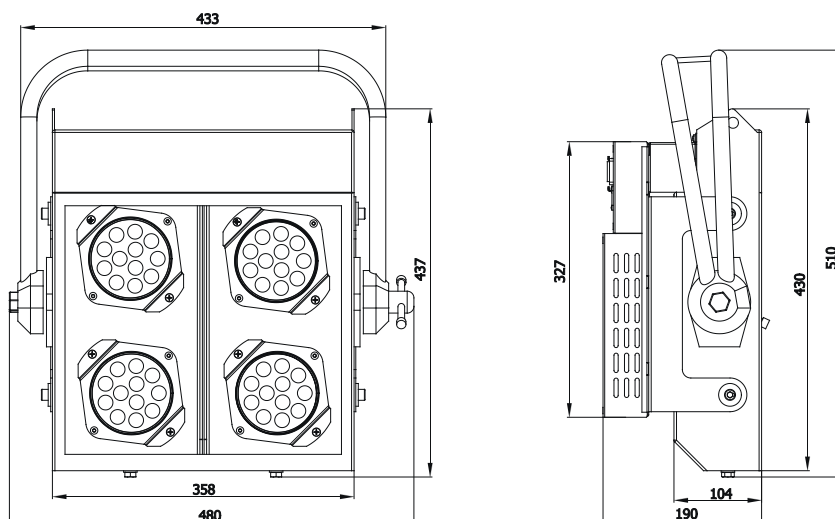

### Weight:

12 kg

## **Optional Accessories**

Set glass frost (No.99011539).....4 pieces

Set film frost (No.99011540).....4 pieces

## **9.Maintenance**

Keep the Led Blinder 148 dry.

Operate only in places where the sufficient air flow to cool the fixture is present

Periodically clean the front transparent cover of LED modules

Use a moist, lint-free cloth. Never use alcohol or solvents!

In order to maintain adequate cooling,dust must be cleaned from the air vents.

### **Replacing the fuse**

**1.Before replacing the fuse, unplug mains lead!**

**2.**Unscrew the fuse holder on the rear side of the LedBlinder 148 with a fitting screwdriver from the housing (anti-clockwise).

**3.**Remove the old fuse from the fuse holder.

**4.**Install the new fuse in the fuse holder.



