

---

## **INVACARE INTERNATIONAL**

**Deutschland, Österreich, Switzerland & Eastern Europe:** Kleiststraße 49 · D-32457 Porta Westfalica.

**France:** Route de St Roch (RD 36) · F-37230 Fondettes.

**United Kingdom & Eire:** South Road · Bridgend Industrial Estate · Bridgend CF31 3PY · UK

**España:** c/ Areny · s/n - Polígon Industrial de Celrà · E-17460 Celrà (Girona)

**Portugal:** Rua Senhora de Campanhã 105 · P-4369-001 Porto

**Belgium & Luxemburg:** Autobaan 14 · B-8210 Loppem

**Danmark:** Sdr. Ringvej 39 · DK-2605 Brøndby

**Sverige & Suomi:** Fagerstagatan 9 · P.O. Box 66 · S-163 91 Spånga

**Norge:** Grensesvingen 9 · N-0603 Oslo

**Nederland:** Celsiusstraat 46 · NL-6716 BZ Ede

**Italia::** Via dei Pini, 62 · I-36016 Thiene (VI).



Part No: QB99612 0605



## **Invacare® Zipper 2 Chair** **User Guide**



## **Introduction**

You have just bought a manual wheelchair from our INVACARE range.

This model offers you all the advantages and characteristics of a wheelchair that has been designed especially to meet your particular requirements.

Great care has been taken with this wheelchair throughout the whole of its manufacturing process. The components have been selected for their quality and inspections have been carried out so that your wheelchair can provide you with full satisfaction.

ISO 7176 PART 15  
REQUIREMENTS FOR INFORMATION DISCLOSURE  
DOCUMENTATION AND LABELLING

MODEL DESIGNATION: ZIPPER 2T CAR TRANSIT MODEL

ISO TEST METHOD	REQUIREMENT	MIN	MAX	ISO TEST METHOD	REQUIREMENT	MIN	MAX	
ISO 7176 Pt 5	Overall Length			ISO 7176 Pt 7	Seat Angle Plane	5.5 deg	5.5 deg	
	Standard Footrests Elevating Footrests	1190mm	1040mm 1330mm	ISO 7176 Pt 7	Effective Seat Depth			
ISO 7176 Pt 5	Overall Width	13"Model 14"Model 15"Model	475mm	475mm	ISO 7176 Pt 7	15"Deep 16"Deep 17"Deep 18"Deep	410mm	
			500mm	500mm			435mm	
			525mm	525mm			460mm	
							485mm	
16"Model 17"Model 18"Model	550mm 575mm 600mm	550mm 575mm 600mm	550mm 575mm 600mm	ISO 7176 Pt 7	Seat Surface Height - Front Edge	500mm		
				ISO 7176 Pt 7	Effective Seat Width	13"Wide 14"Wide 15"Wide 16"Wide 17"Wide 18"Wide	365mm	
							395mm	
							420mm	
445mm								
470mm								
495mm								
ISO 7176 Pt 5	Folded Length	720mm		ISO 7176 Pt 7	Backrest Angle	16deg		
ISO 7176 Pt 5	Folded Width	250mm		ISO 7176 Pt 7	Backrest Height	448mm		
ISO 7176 Pt 5	Folded Height	740mm		ISO 7176 Pt 7	Footrest to Seat Distance	380mm	500mm	
ISO 7176 Pt 5	Total Weight		14.8Kg	ISO 7176 Pt 7	Leg to Seat Surface Angle	115deg		
C.E.N	Weight of the Heaviest Part	n/a	n/a	ISO 7176 Pt 7	Armrest to Seat Distance	227mm		
ISO 7176 Pt 1	Static Stability Downhill	22 deg	24 deg	ISO 7176 Pt 7	Front Armrest to Backrest Full Length	320mm 260mm		
ISO 7176 Pt 1	Static Stability Uphill	13 deg	18 deg	ISO 7176 Pt 7	Horizontal Location of Axle	0mm		
ISO 7176 Pt 1	Static Stability Sideways	16 deg	16 deg	ISO 7176 Pt 5	Minimum Turning Radius			
ISO 7176 Pt 4	Energy Consumption Range	n/a	n/a	ISO 7176 Pt 5	Turn Around Width Limiting Walls			
ISO 7176 Pt 2	Dynamic Stability Uphill	n/a	n/a	ISO 7176 Pt 7	Handrim Diameter	n/a		
ISO 7176 Pt 10	Obstacle Climbing	n/a	n/a					
ISO 7176 Pt 6	Maximum Speed Forward	n/a	n/a					
ISO 7176 Pt 3	Minimum Braking Distance	n/a	n/a					

The Wheelchair conforms to the following standards:

ISO 7176 Pt 8	Static, Impact and Fatigue Strength	Yes
ISO 7176 Pt 9	Climatic Tests	N/A
ISO 7176 Pt 14	Power and Control	N/A
ISO 7176 Pt 16	Resistance to Ignition	Yes

ISO 7176 PART 15  
REQUIREMENTS FOR INFORMATION DISCLOSURE  
DOCUMENTATION AND LABELLING

MODEL DESIGNATION: ZIPPER SELF PROPEL WHEELCHAIR

ISO TEST METHOD	REQUIREMENT	MIN	MAX	ISO TEST METHOD	REQUIREMENT	MIN	MAX		
ISO 7176 Pt 5	Overall Length	1000mm	1105mm	ISO 7176 Pt 7	Seat Angle Plane				
				ISO 7176 Pt 7	Standard Chair Hemiplegic Chair	5.7deg -1deg	5.7deg -1deg		
ISO 7176 Pt 5	Overall Width	13"Model 14"Model 15"Model	535mm 560mm 585mm	535mm 560mm 585mm	ISO 7176 Pt 7	Effective Seat Depth	15"Deep	410mm	---
							16"Deep	435mm	---
							17"Deep	460mm	---
							18"Deep	485mm	---
16"Model 17"Model 18"Model	610mm 635mm 660mm	610mm 635mm 660mm	610mm 635mm 660mm	ISO 7176 Pt 7	Seat Surface Height - Front Edge	500mm	---		
				ISO 7176 Pt 7	Effective Seat Width	13"Wide	365mm	---	
						14"Wide	395mm	---	
						15"Wide	420mm	---	
16"Wide	445mm	---							
17"Wide	470mm	---							
18"Wide	495mm	---							
ISO 7176 Pt 5	Folded Length	720mm		ISO 7176 Pt 7	Backrest Angle	16deg			
ISO 7176 Pt 5	Folded Width	250mm		ISO 7176 Pt 7	Backrest Height	448mm			
ISO 7176 Pt 5	Folded Height	740mm		ISO 7176 Pt 7	Footrest to Seat Distance	380mm	500mm		
ISO 7176 Pt 5	Total Weight		14.8Kg	ISO 7176 Pt 7	Leg to Seat Surface Angle	115deg			
C.E.N	Weight of the Heaviest Part	n/a	n/a	ISO 7176 Pt 7	Armrest to Seat Distance	227mm			
ISO 7176 Pt 1	Static Stability Downhill	22 deg	24 deg	ISO 7176 Pt 7	Front Armrest to Backrest Full Length	320mm 260mm			
ISO 7176 Pt 1	Static Stability Uphill	13 deg	18 deg	ISO 7176 Pt 7	Horizontal Location of Axle	0mm			
ISO 7176 Pt 1	Static Stability Sideways	16 deg	16 deg	ISO 7176 Pt 5	Minimum Turning Radius				
ISO 7176 Pt 4	Energy Consumption Range	n/a	n/a	ISO 7176 Pt 5	Turn Around Width Limiting Walls				
ISO 7176 Pt 2	Dynamic Stability Uphill	n/a	n/a	ISO 7176 Pt 7	Handrim Diameter	n/a			
ISO 7176 Pt 10	Obstacle Climbing	n/a	n/a						
ISO 7176 Pt 6	Maximum Speed Forward	n/a	n/a						
ISO 7176 Pt 3	Minimum Braking Distance	n/a	n/a						

The Wheelchair conforms to the following standards:

ISO 7176 Pt 8	Static, Impact and Fatigue Strength	Yes
ISO 7176 Pt 9	Climatic Tests	N/A
ISO 7176 Pt 14	Power and Control	N/A
ISO 7176 Pt 16	Resistance to Ignition	Yes

## **Note for wheelchair users**

INVACARE provides a wide range of wheelchairs to meet the requirements of users. However, the decision on the type of model to be prescribed rests exclusively with qualified advisers.

INVACARE or its appointed representative shall not be held responsible if a wheelchair is used that is unsuitable for the user's level of disability, if the wheelchair itself is incorrectly used or if a problem arises due to poor maintenance.

The information set out in this manual may be modified without prior notice. This manual contains copyright information. All rights are reserved. No part of this document may be photocopied or reproduced without prior written agreement from INVACARE or its appointed representative.

**This manual gives details of all the options of the ZIPPER 2 range of wheelchairs. It describes the options, operation and adjustments that may be required. However, your INVACARE retailer will be able to give you further information and demonstrations.**

### **SAFETY NOTICE**

**PLEASE ENSURE THE WHEELCHAIR IS  
FULLY OPENED AND THE SEAT RAILS ARE  
LOCATED IN THE SEAT SADDLES BEFORE SITTING DOWN**

## Table of contents

	Page
<b>Note for Wheelchair Users</b> .....	<b>1</b>
<b>Table of contents</b> .....	<b>2-3</b>
<b>1. Safety and operating limits</b> .....	<b>4-13</b>
1.1 Weight limit .....	4
1.2 Reaching for an object from a wheelchair .....	4-6
1.3 Transferring to other seats .....	7-8
1.4 Tilting the wheelchair .....	9-10
1.5 Kerbs .....	10
1.6 Stairs .....	11
1.7 Upward and downward slopes .....	12-13
<b>2. Use</b> .....	<b>13-14</b>
2.1 Folding and unfolding the wheelchair .....	13-14
2.2 Propelling the wheelchair .....	14
<b>3. Summary of safety instructions</b> .....	<b>15</b>
<b>4. General description</b> .....	<b>16-17</b>
<b>5. Backrests</b> .....	<b>18</b>
<b>6. Seat</b> .....	<b>18</b>
<b>7. The various types of armrest</b> .....	<b>19-20</b>

## Table of contents cont.

<b>8. Folding chassis</b> .....	<b>21</b>
<b>9. Rear wheels</b> .....	<b>21-22</b>
<b>10. Castors</b> .....	<b>23</b>
<b>11. Brakes</b> .....	<b>23-24</b>
<b>12. Footrests</b> .....	<b>24-26</b>
<b>13. Calf straps and heel loops</b> .....	<b>26</b>
<b>14. Backrest Extension</b> .....	<b>27</b>
<b>15. Rear Anti-tippers</b> .....	<b>28</b>
<b>16. Transit version</b> .....	<b>28</b>
<b>17. Amputee kit</b> .....	<b>29</b>
<b>18. Trays</b> .....	<b>29</b>
<b>19. Safety belt</b> .....	<b>29</b>
<b>20. Spoke guards</b> .....	<b>29</b>
<b>21. Tipping Lever</b> .....	<b>30</b>
<b>22. Routine checks and maintenance</b> .....	<b>31-32</b>
<b>23. Transport</b> .....	<b>32-33</b>
<b>24. Guarantee</b> .....	<b>34</b>
<b>25. Storage</b> .....	<b>34</b>
<b>26. Cleaning</b> .....	<b>34</b>

# 1-Safety and operating limits

## Stability and equilibrium

To ensure that the wheelchair remains stable and is manipulated correctly, you must always maintain good equilibrium. Many actions cause the user of a wheelchair to reach out, lean over or move about within the wheelchair and outside it. These actions will change your centre of gravity and weight distribution of the wheelchair.

Your wheelchair has been designed to remain stable for normal everyday use if it is used correctly taking the precautions recommended in this manual.

### 1.1 - Weight limit

**The maximum user weight limit for S & T models is 115kg and 100kg for the SL & TL models.**

This weight includes accessories such as a compact oxygen cylinder or other equipment required by the user.

However, the wheelchair user's degree of activity is important. For example, an active user weighing 75 kg may subject the wheelchair to more stress than a user weighing 115 kg. We recommend very active wheelchair users to choose an appropriate design of wheelchair. Your INVACARE approved distributor will advise you on the best model.

### 1.2 - Reaching for an object from a wheelchair

The limitations on reaching out from a wheelchair shown in figure 1 have been produced using a representative sample of wheelchair users.

Only the arms should extend beyond the seat of the wheelchair. For safety reasons, the body and head should remain within the wheelbase.

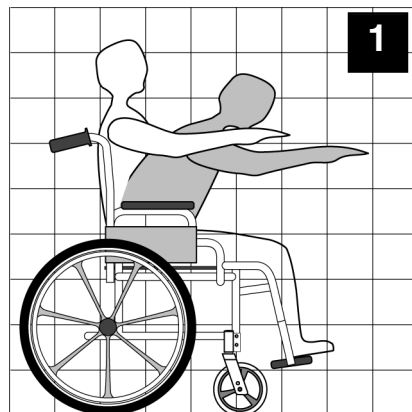

Position the castors to give the longest possible wheel-base (Figure 2). Lock the manual brakes on the rear wheels.

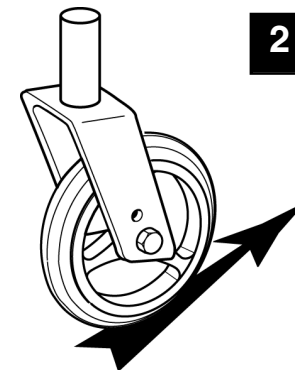

### Leaning forwards

(Figures 3, 4 and 5):

Move the wheelchair as close as possible to the object you wish to reach. Only reach out to take what is within arm's length in normal sitting position.

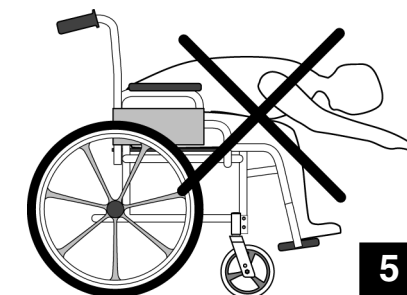
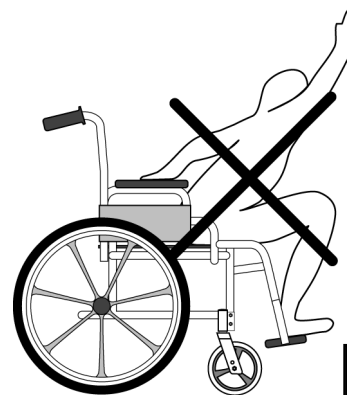
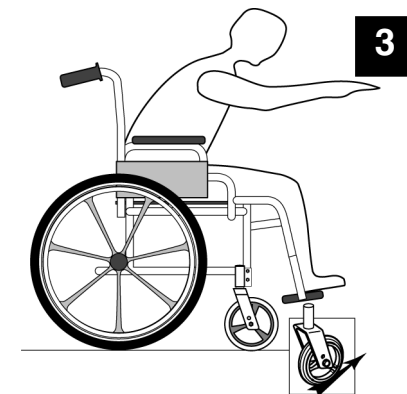

## Leaning backwards

(Figures 6 and 7)

Move the wheelchair as close as possible to object you wish to reach. Only lean back for objects that are within arm's length in normal sitting position.

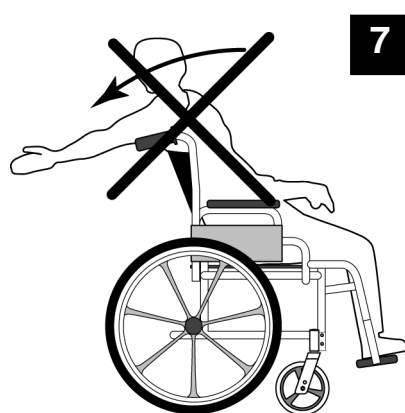
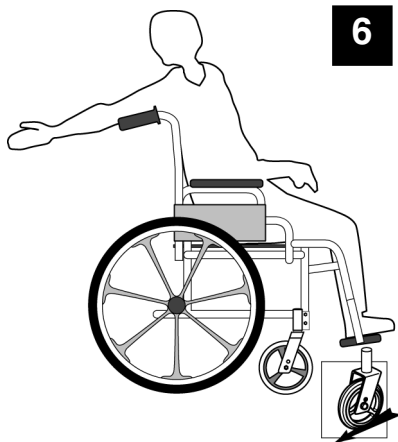

## Leaning to one side

(Figure 8)

This is the most dangerous manoeuvre as it is easy to tip sideways.

To move up to the object and lean over, you must use the castors as a means of keeping the wheelchair stable and balanced. (Figure 2)

For your safety, it is essential to be in the correct position.

Do not try to pick something up from the floor if this would upset your balance.

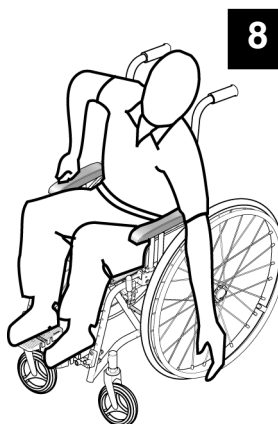

## 1.3 - Transferring to other seats

It is possible to move from and to a manually propelled chair if the following guidelines are followed.

INVACARE does not recommend any particular method for transferring: This is the responsibility of a medical adviser who should consider your level of disability and type of wheelchair.

When transferring, either to get out of or return to your wheelchair, make sure:

That the gap between the two seats is as small as possible. (Figures 9 and 10)

That the manual brakes on the rear wheels are on to prevent the wheels moving. (Figure 11)

Turn both castors towards the seat to which you wish to move. Lift up the footplates. Do not stand on the footplates.

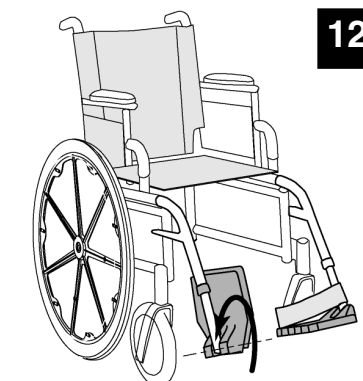
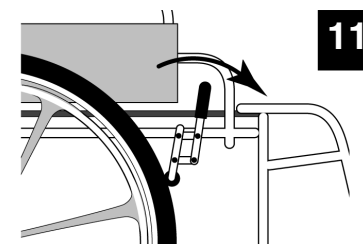
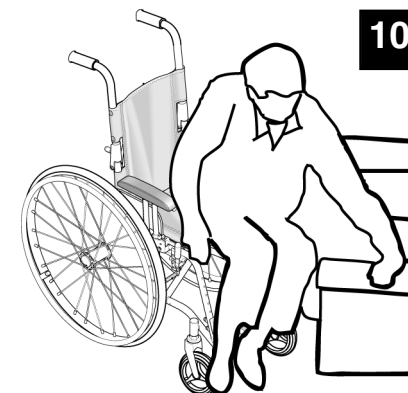
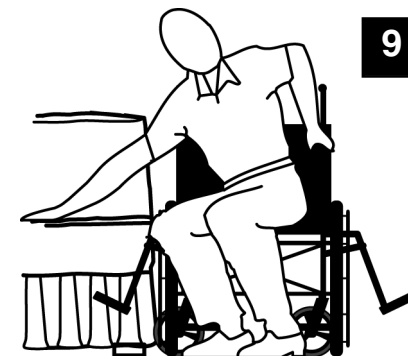

If possible, fold back the footrest supports to the side to clear the passage. (Figure 13)

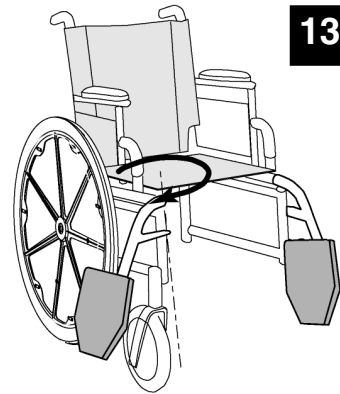

If possible, remove the armrests on the side between the wheelchair and the other seat (Figure 14).

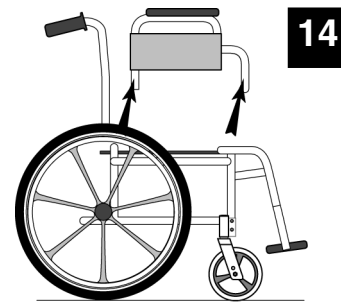

**NB**

Never stand up on the footplates. (Figure 15).

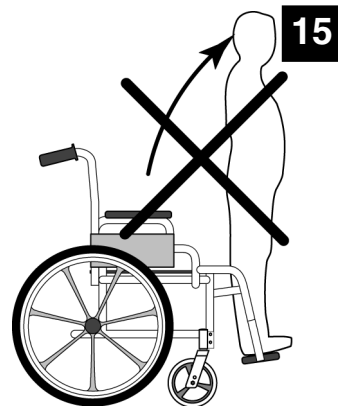

## 1.4 - Tilting (balancing on the rear wheels)

### Tilting without help from a third person

Wheelchairs in the INVACARE range have been designed for use by those who have mastered the technique of balancing on the rear wheels without help from a third person. However, you should never exceed the limitations of the wheelchair. Repeated shock on the castors caused by tipping the wheelchair up yourself may affect the rigidity or settings of your wheelchair. If your wheelchair is fitted with accessories, these may affect the methods used for balancing on the rear wheels.

When you wish to learn a new technique, consult an experienced person for advice in using your type of wheelchair.

### Tilting with assistance from a third person:

The user should be sitting correctly and firmly in the chair or if unable to support themselves, should be strapped in position to prevent him falling out of the chair.

If a wheelchair user needs assistance in tilting the chair, the assistant must know how to use his body correctly. Keep your back straight and bend at the knee to tilt the wheelchair. Never exert too much force. The medical team in charge of the user will advise you in the methods best suited to your morphology. The INVACARE approved distributor will provide you with information on the risks of using the wheelchair incorrectly if the wheelchair has removeable parts such as armrests or leg rests. **These must NEVER be used as aids when lifting** as they may inadvertently become detached and cause injury .

To tilt the wheelchair, a third person should grip the handles firmly. (Figure 16) Warn the user of the wheelchair before tilting it and remind him/her to lean backwards. Check that the user's feet and hands are clear of all the wheels. Place a foot on the foot step tube and push smoothly until the wheelchair is at the point of equilibrium. At this stage, the helper will feel a difference in weight distribution which usually occurs at an angle of about 30°. Turn the wheelchair in the direction required and negotiate the obstacle.

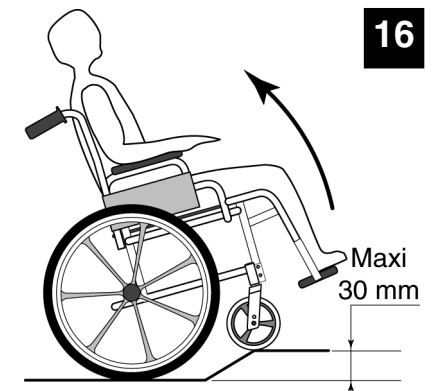



Lower the front of the wheelchair smoothly, holding the handles firmly. Use your weight on the foot step tube to act as a counterweight. Do not lower the wheelchair suddenly for the last few centimetres before returning to the normal position. This might hurt the user.

### 1.5 - Kerbs or obstacles 30 to 50 mm high

#### Method 1 - Negotiating the obstacle forwards

(Figure 17)

The helper should tilt the wheelchair until the castors have passed over the kerb. Move the wheelchair forwards and lower the castors gently onto the pavement. Push the wheelchair until the rear wheels touch the kerb. Lift and push until the rear wheels have mounted the kerb. Do not just lift by the handles on the backrest.

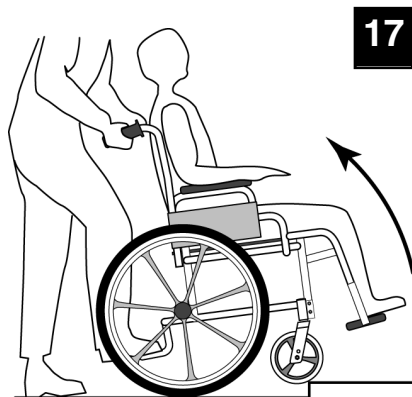

#### Method 2

(Figure 18)

The helper should stand on the pavement and turn the wheelchair until the rear wheels are against the kerb. Tilt the wheelchair backwards to the point of equilibrium and, in a continuous movement, pull the wheelchair until the rear wheels mount the kerb and pass onto the pavement. Do not lower the castors to the ground until you have pulled the backrest of the wheelchair sufficiently far to clear the kerb.

NB: Folding backs should always be checked to ensure they are engaged.

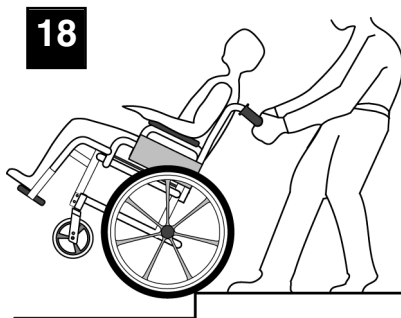

### 1.6 - Steps, stairs or obstacles over 50 mm high

We recommend that you take very great care when taking a wheelchair up or down stairs. Two people are required for this.

#### ADVICE TO THIRD PERSONS

Make sure that you get hold of fixed, non-removable parts only. Use the following procedure for going up stairs. (Figure 19):

Tilt the wheelchair to its point of equilibrium. One helper (at the back) holds the wheelchair up against the first step, gripping the handles firmly to lift.



The second helper, holding firmly a fixed part of the front frame, lifts the wheelchair above the stairs and holds it while the first helper places one foot on the following step and repeats the operation.

The wheelchair must not be lowered until the last step has been negotiated and until the chair is clear of the stairs.

#### **Escalators**

Do not use an escalator when moving a wheelchair from one floor to another. This might cause serious injury.

## 1.7 - Upward and downward slopes (operating limits)

Do not attempt to go up or down slopes greater than 9% without assistance. (Figure 20)

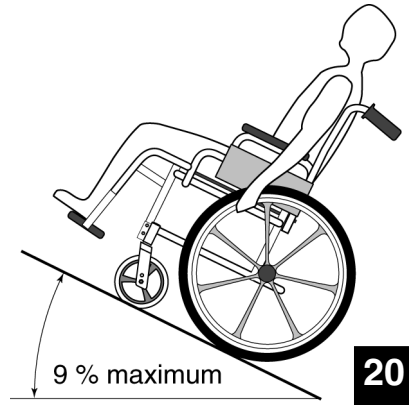

Always go straight up and down slopes otherwise the wheelchair might overturn. (Figure 21)

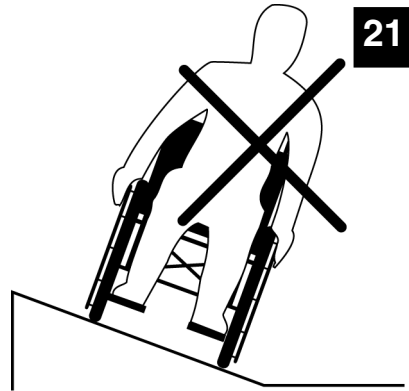

### Upward slopes

Lean the upper part of the body forward and push the chair forward with short quick thrusts on the handrims to maintain speed and control direction. If you wish to take a rest, apply both brakes when stopping. (Figure 22).

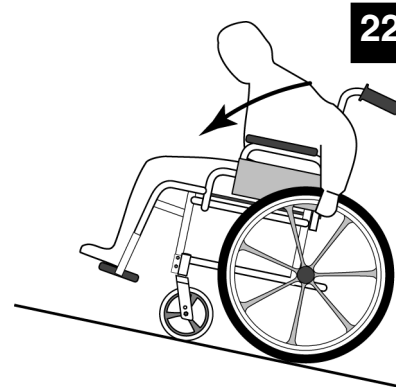

NB: The use of Anti Tippers is recommended in traversing of upward slopes.

### Downward slopes

Lean backwards carefully and allow the handrims to slide through your hands. Be ready to react at any moment to check the speed and direction by keeping in close contact with the handrims. The manual brakes should not be used to slow you down. (Figure 23)

If you are going up or down a slope avoid turning sharply and never try to go up or down diagonally.

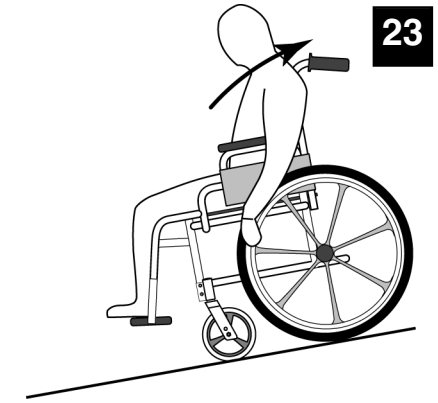

## 2-Use

### 2.1 - Folding and unfolding the wheelchair

Wheelchair with fabric upholstery.

#### To fold

Lift the footplates .

Release the backrest tensioner if necessary.

Using both hands, take the centre of the seat fabric at the front and back edges and raise it. (Figure 24).

Or, tilt the wheelchair to one side and close it using the handles on the back rest or the armrests. (Figure 25).

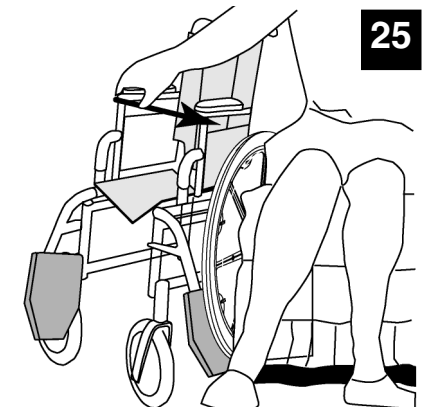
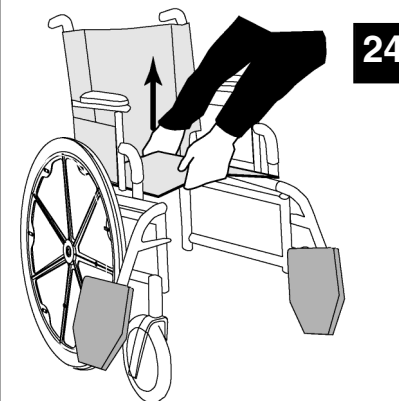

## To unfold

(Figure 26)

Unfold the wheelchair by taking hold of the armrest or the side of the chair nearest to you, tip the chair sideways (lifting the rear wheel and the caster from the ground) and press on the tube supporting the seat upholstery until it is fully down. The seat upholstery should be fully open .

### ***NB***

Ensure that the seat rails are fully engaged in the plastic carriers before sitting down.

To avoid injury, keep hands and fingers away from moving parts (armrests, folding frame, footrest supports or leg rests, etc).

## 2.2 - Propelling the wheelchair

The wheels of your wheelchair are fitted with handrims. (Figure 27)  
The qualified personnel will be able to advise you on the most appropriate way of propelling yourself.

Various accessories may be fitted to improve the grip (plastic coatings, studs).

Lean the upper part of the body forward and push the chair forward with short quick thrusts on the handrims to maintain speed and control direction.

Be ready to react at any moment to check the speed and direction by

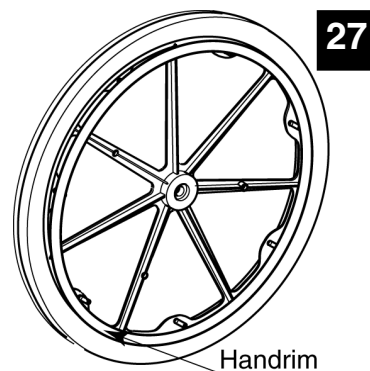
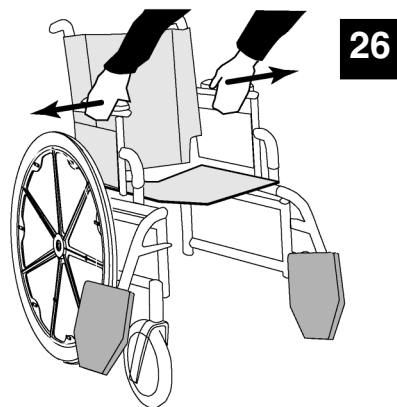

## 3. Summary

of instructions for use for improved safety

- User **weight limit** (including accessories): 115kg for an adult wheelchair, 50 kg for a child's wheelchair
- **Do not try** to reach objects if you have to move forward on the seat
- **Do not try** to reach objects on the ground if you have to lean down beyond the safety limits
- **Do not lean** too far back to reach objects behind you: you may tip over.
- **Do not move** your weight, or your sitting position in the direction in which you wish to go: you may tip over.
- **Always apply both manual brakes** before trying to get out of or back into the wheelchair.
- **The manual brakes are not designed for slowing you down.**
- **Do not try** to stop a moving wheelchair using the manual brakes.
- **Do not tilt the wheelchair without assistance from a third person when negotiating obstacles more than 30 mm high**
- **Do not use** an escalator for moving a wheelchair from one floor to another. (This may cause serious injury.)
- **Do not use** your wheelchair if the tyres are not inflated to the correct pressure shown on the side.
- **Do not over-inflate** the tyres. Failure to comply with these instructions may cause the tyre to burst and cause bodily injury.
- **Carry out** the regular checks recommended in this guide and by your INVACARE approved retailer.
- **Use** your wheelchair with respect for other people
- **Do not use** your wheelchair as a transport seat in a vehicle. Unless it is not practical for the user to be transferred (Refer to section 23 - Transport).

## 4. Description

Each wheelchair is specially designed to meet the requirements of its user. This manual describes how to adjust the chairs in this range, enabling you to find out how to adjust the wheelchair to suit your needs.

### General description

Your wheelchair has a number of main parts which will be mentioned throughout this manual. These parts are described below.

Support is provided by the **backrest, seat and armrests**.

The **folding chassis** comprises of the **side frames and folding cross brace**.

This is the essential supporting framework of the wheelchair on which all the other parts are mounted.

The **rear wheel** comprises of the **wheel, axle and handrim**.

The rear wheels provide contact with the ground and are driven by turning the handrims.

The **front castors** comprise of the fork and wheels.

The front wheels provide contact with the ground and the rotating forks steer the chair.

#### Manual brake

The manual brake is used to park the wheelchair.

#### Swing away footrest support and leg rest

These are connected to the chassis and can be swung away to make transfer easier to and from the wheelchair.

The **footplate assembly** comprises of the **adjustable tube and foot plate**. These support your feet.

#### The heel support strap or calf support strap

These two straps support your feet or legs in the best position. These parts are illustrated on the following diagram.

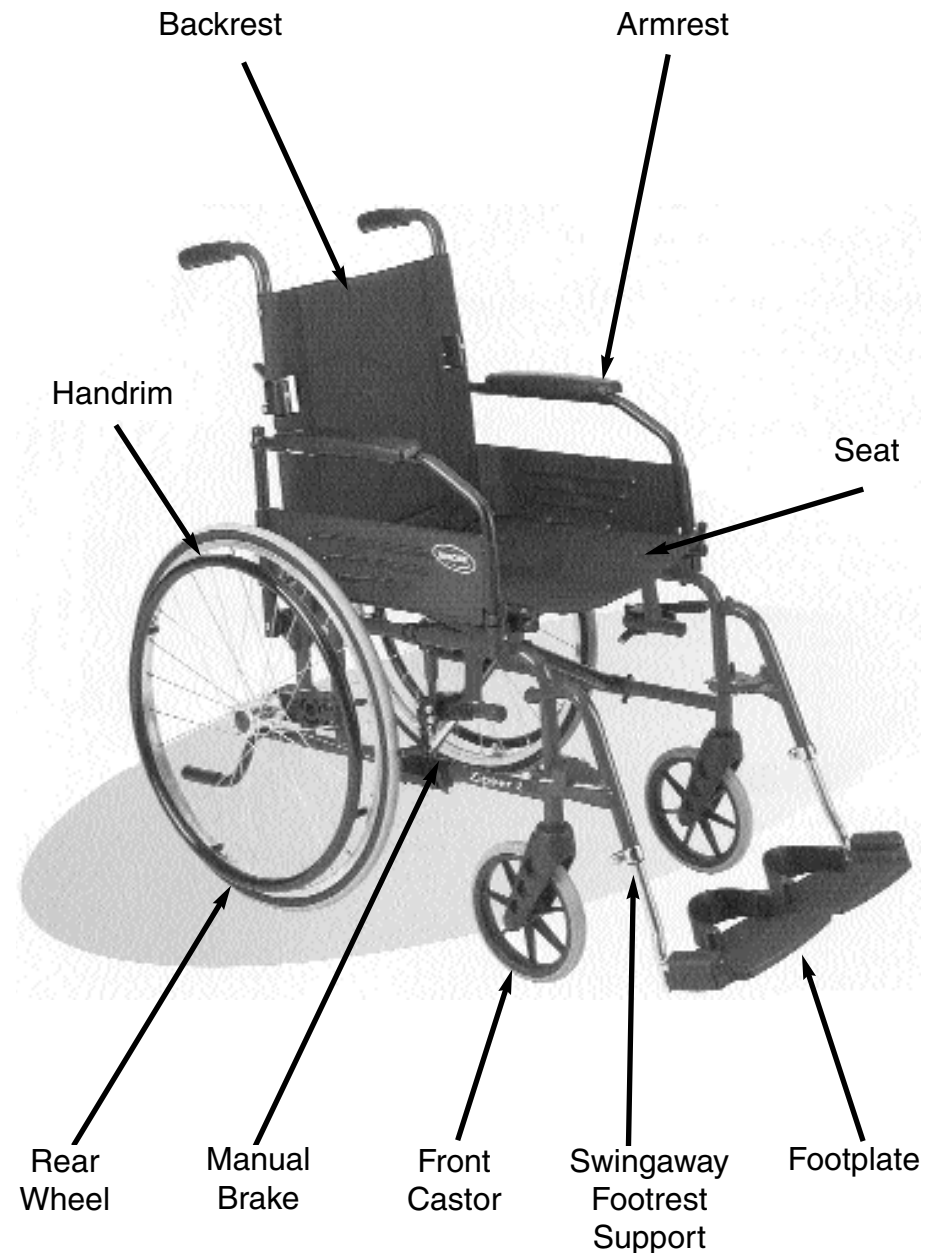

## 5. Backrest

Photographs 1 and 2

The backrest can be folded at the middle by means of a locking mechanism and can be operated by either the user or an attendant.

- Use: To fold the backrest, pull both black plastic locking levers (A) downwards and fold the top part of the backrest to the back and then down. Carry out these operations in the reverse order to return the backrest to its normal position, making sure that the locking mechanisms (A) are secure.

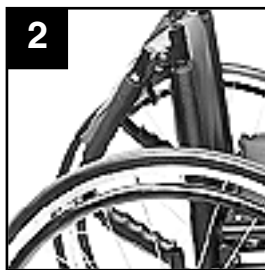
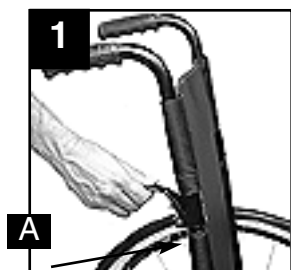

## 6. Seat

### 6.1 Seat

Photograph 3

- Your seat upholstery is screwed onto the seat tubes of the folding cross brace.

- Adjustment: This model requires no adjustment. Just check regularly that the screws (A) are tight. If the washers (B) are loose, these screws should be tightened. If the problem continues, contact your INVACARE retailer and ask him to change the mounting for safety reasons.

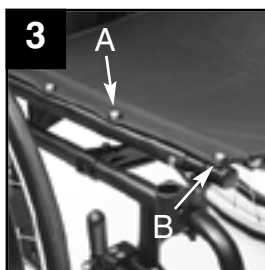

### 6.2 Seat cushion

The seat cushion is placed on the upholstery and must be removed when folding the chair.

## 7. The various types of armrest

The armrests are fitted in pairs on the wheelchair. When removing them, remember that there is one armrest for the right hand side and another for the left hand side.

### Removable, swingaway desk armrest

Photograph 4 & 5

The arm rest has a tube which supports the front and back locking devices as well as the armrest pad. This armrest can be swung towards the back, and can also be removed if required.

- Use:

To swing away, turn the front lock (A) in order to release. Lift the armrest and position it towards the back in order to carry out lateral transfers. Carry out these operations in reverse order to replace the armrest. Turn the front lock (A) in order to firmly secure the armrest to its location.

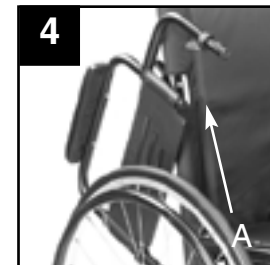

Removal: Turn the front lock (A) and the back lock (B) in order to release.

Lift up the armrest. Carry out this operation in reverse order to replace the armrest. Turn the front lock (A) and lock (B) in order to firmly secure the armrest to its locations.

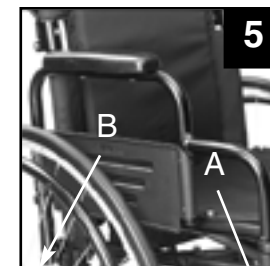

- Adjustment: This model does not require any adjustment.

### Full length swingaway and removable armrest

Photographs 6

The arm rest has a tube which supports the front and back locking devices as well as the armrest pad. This armrest can be swung towards the back, and can also be removed if required.

- Use:

To swing away, turn the front lock (A) in order to release. Lift the armrest and position it towards the back in order to carry out lateral transfers. Carry out these operations in reverse order to replace the armrest. Turn the front lock (A) in order to firmly secure the armrest to its location.

Removal: Turn the front lock (A) and the back lock (B) in order to remove the armrest.

Lift up the armrest. Carry out this operation in reverse order to replace the armrest. Remember that the curved part of the tube should be facing forward. Turn the front lock (A) and the lock (B) in order to firmly secure the armrest to its locations.

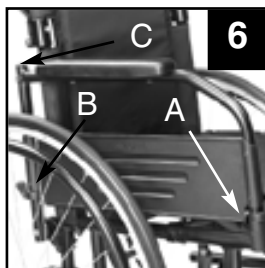

Note: The armrest is reversible so that slot C can be used to hold an NHS tray.

- Adjustment: This model does not require any adjustment.

### Removable, swing away adjustable height armrest

Photographs 7 and 8

- The adjustable height armrest has a tube which supports the back and front locks as well as the adjustable armpad tube. This armrest can be swung towards the back and can be removed, if required.

- Use:

To swing away, turn the front lock (A) in order to release. Lift the armrest and position it towards the back in order to carry out lateral transfers. Carry out these operations in reverse order to replace the armrest. Turn the front lock (A) in order to firmly secure the armrest to its location.

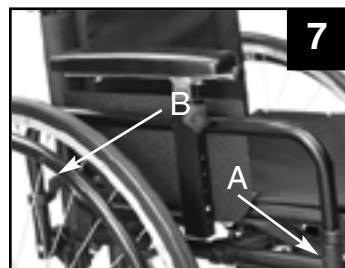

Removal: Turn the front lock (A) and the back lock (B) in order to remove the armrest.

Lift up the armrest. Carry out this operation in reverse order to replace the armrest. Remember that the incurved part of the tube should be facing forward. Turn the front lock (A) and the lock (B) in order to firmly secure the armrest to its locations.

Height adjustment: Loosen the hand wheel (D) and push in the button spring (E), adjust to the desired height and tighten the hand wheel (D). The hand wheel (D) can be replaced by a screw (not included) for users who do not often change the height of the armrest.

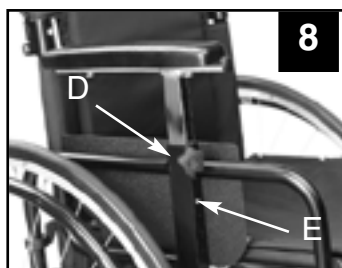

## 8. Chassis

### Side Frames

- The side frames provide the mounting points for the rear wheels and the castors.

- Adjustment: No adjustment is possible on this series of wheelchair.

### Folding cross brace

- The folding cross brace has two members which enable the wheelchair to be folded.

- Adjustment: No adjustment is required. To fold or unfold your wheelchair, refer to this user and safety manual.

## 9. Rear wheels

### Wheels

Photograph 9

- The rear wheels are positioned on rear wheel mounting blocks which determine the rearward stability. This position should only be adjusted by a qualified technician on the advice of the qualified advisor.



The rear wheels have a diameter of either 600 mm, 550 mm, or 500 mm. They are equipped with spokes and handrims. They can have pneumatic tyres or solid tyres and can be connected to the side frame by means of a fixed axle or a quick release axle.

Tyre pressure.

The pressure is shown on the tyre and must never be exceeded. The maximum permitted pressure is 450 kPa (65 PSI - 4.5 bar). Remember that the tyre pressure on both wheels should be the same to ensure perfect steering.

In case of a puncture, the tyre has to be removed from the rim. Press the valve to let all the remaining air out of the inner tube. Pull the tyre off the rim. Repair or replace the inner tube. Put the tyre back on the rim. Inflate the tyre to the required pressure.

- Note: It may be necessary to use one or two tyre removal tools (not supplied).

### Warning

Applicable only to chairs fitted with 24" wheels. These chairs are assembled with the wheels set in the rearward position. It is important that the chairs are not re-configured with the wheels set in the "forward" position; this would allow the footrest hangers to disengage the brake levers when swung away from their locked position, causing the chair to become unstable.

### Handrims

- The handrims are used by the user to drive the wheelchair.
- NB: As the handrims are in contact with your hands, make sure that they are not damaged and that the surface has no parts which might cause injury to the hands.
- Adjustment: No adjustment is required for the handrims.

### Axles

Photographs 10 and 11

- The axles link the back wheels to the chassis. They are fixed or quick releasing.

- Quick release wheels

Removal: Push on the quick release button head with your finger and pull the wheel towards the outside of the chair.

- Assembly: Push on the quick release button head with your finger and locate axle through the axle bush, making sure that the axles are secured (no axial movement).

- Fixed wheels.

No adjustment is required, however, check on a weekly basis that the axle / nut are secure.

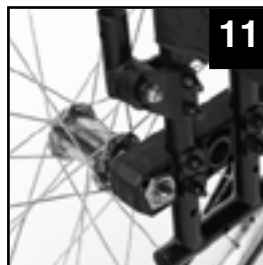
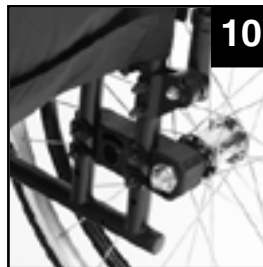

## 10. Castors Front wheels

- The front wheels have a diameter of either 190mm or 125 mm available in solid puncture-proof tyres only. No adjustment is necessary for the front wheels.

### Forks

Photograph 12

- The fork connects the chassis and the wheel.
- Adjustment: The forks do not require adjustment. Check that the fork rotates freely.



## 11. Manual brakes

Photograph 13

### Brakes

- The manual brakes are used to immobilise the wheelchair in a stationary position. They are not intended for slowing down and should not be used when the wheelchair is moving. They should be applied together.

- Use: The brakes are operated by moving the brake handle (A) towards the front of the wheelchair. When the brakes are applied, the wheelchair should resist movement.

- Adjustment: It may be necessary to adjust the brakes after repairing a puncture or because of wear on the pneumatic or solid tyre. Slacken clamp screws and adjust the brake assembly to achieve adequate braking. Tighten the clamp screws firmly after adjustment.

- **Note:** The brakes are fitted in pairs to the wheelchair. When adjusting or removing, remember that there is one brake for the right hand side and another for the left hand side.

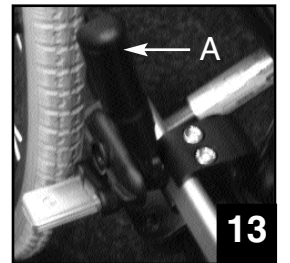

## Brake extension

Photograph 14

- The brakes may be equipped with a handle extension to assist attendants/user who have insufficient strength or difficulty in reaching the standard brake handles.

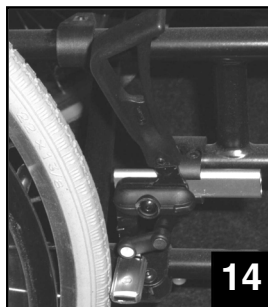

## 12. Footrest

### Swing away footrest supports

Photograph 15 and 16

The footrest supports can be swung away to the outside/rear of the wheelchairs to free the front of the wheelchair and making it easier for the user to transfer to another seat. They can be removed.

- Use: To swing the support to the outside, press the release mechanism lever (A). Rotate the support carefully to the outside of the wheelchair.

To return the support, repeat the operations in the reverse order. Check that the release mechanism (A) has automatically locked.

To remove the support, carry out the same operation as for swing back and lift the support upwards. To refit it, offer the support in the open position, align the holes (B) on the pivots (C) and press down. Rotate the support to the locked position.

- Adjustment: The footrest supports cannot be adjusted.

- Note: The footrest supports are fitted in pairs to the wheelchair. When adjusting or removing, remember that there is one support for the right hand side and another for the left hand side.

### Elevating leg rests

Photographs 17 and 18

The leg rests shown are leg rest supports with an integral pad for supporting the lower leg. The leg rests can be swung away and removed.

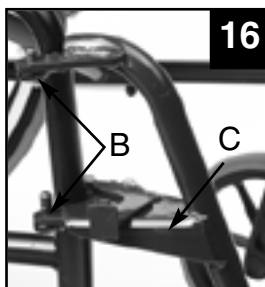
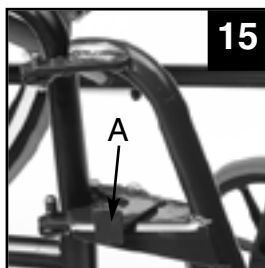

- Use: the operations for swing away and removing are the same as for the footrest supports (10.1).

- Adjustment: To adjust the angle of the leg rest, lift it upwards to the angle required. To lower the leg rest, hold the leg in one hand and operate the release lever (A) with the other hand. Lower to the required position.

The calf support pad can be pivoted when folding the wheelchair. The position can also be set on the mounting tube in one of three locations. It can also be set along the mounting tube by sliding into the chosen location (18).

- NB: The elevating legrests are fitted in pairs to the wheelchair. When adjusting or removing, remember that there is one elevating legrest for the right hand side and another for the left hand side.

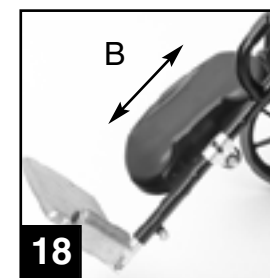
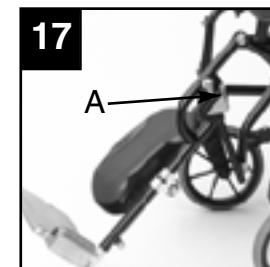

## Footplate Assemblies

### Independent footplates for footrest supports

Photograph 19

The footplate assemblies comprise of an adjustment tube and footplate and are intended solely as a foot support when you are sitting in the wheelchair and should not be used for standing. The position of your feet can be retained by either heel loops or a calf strap. Each footplate assembly can be adjusted in height. The footplates can be pivoted to an upright position to aid front transfers.

- Adjusting the footrests on the supports: Release the nut (A), position the footplate assembly at the required height in the footrest support tube, tighten the nut to secure.



### Independent footplate assemblies for elevating leg rests

Photograph 20

The foot rests comprise a pair of mounting tube and rest assemblies and are intended solely as a foot support when you are sitting down. Each footplate assembly can slide into the elevating legrest on the appropriate side and its height can be adjusted.

The footplates can be raised for front transfers.

- Adjusting the footplate assemblies on the leg rests: Release the set screw (A) and position the foot rest assembly at the required height in the leg rest tube. Tighten set screw (A).

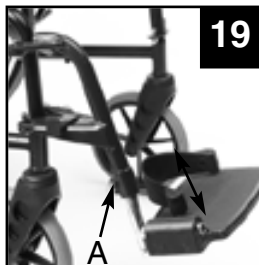

### 13. Calf straps

To finalise the foot and leg position, your wheelchair has a calf strap on the foot rest supports.

- Adjustment: Your calf strap is adjustable, just pull the end of the strap to release the hook and eye fastening and adjust the tension. Place the end back in position on the fastener and press together to ensure a good fixing.

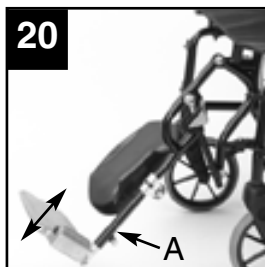

The strap is removable.

### Heel support straps

To finalise the foot position, the rest can be equipped with heel straps.

The strap cannot be removed and should be repositioned towards the front when folding back the footplate.

## 14. Backrest Extension

Photograph 21

The backrest extension has two uprights (B) and a backrest extension upholstery. The locating pegs should only be fitted to the push handles of the backrest by a qualified technician.

When refitting, make sure that it is firmly fixed onto the locations fitted to the the backrest tubes. Raise the head rest assembly to remove it from the tubes of the recliner backrest.

- Adjustment: No adjustment is required for this extension. However, it can be removed for transport.

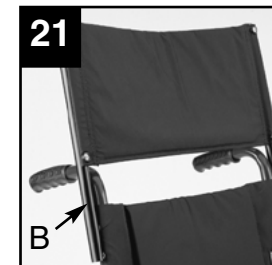

### FITTING INSTRUCTIONS BACKREST EXTENSION FOR VEHICLE TRANSPORT

When transporting the chair the backrest extension must be secured to the push handles.

Using a M5 x 30mm Hex Hd screw and location ring (See photo below)

Slide the location ring inside the slot on the extension tube, and then feed the Hex Hd screw through the tube and location ring and firmly secure to the push handle.

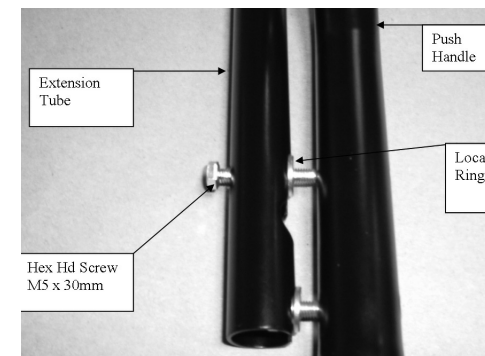

## 15. Rear Anti-tippers

Photograph 22

The anti-tippers help prevent you from tipping over when the rear wheels are incorrectly positioned, or when the user or attendant mishandles the wheelchair.

- Use: The anti-tippers fit into the rear tubes of the side frames (A). Fit the anti-tippers into the side frame rear tube, until the button springs are positioned in the holes of the rear tube (A). Carry out these operations in the reverse order to remove. You can leave the anti-tip casters on the wheelchair even if you do not wish to use them. Just depress the button spring and rotate the entire anti-tipper unit a half turn. (180 deg.)

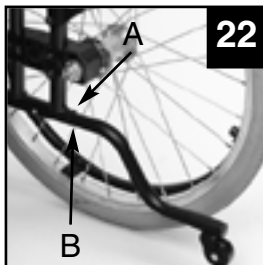

- **Note:** The anti-tippers are not to be used as tipping levers.

## 16. Transit kit

Photos 23 and 24

The transit kit includes a manual brake for operation by an attendant.

**Note:** - This brake is different to the self propelled version. Also included is a choice of either pneumatic or solid tyred wheels.

- Adjustment: It may be necessary to adjust the brakes after repairing a puncture or because of wear on the pneumatic or solid tyre. Slacken clamp screws (B) and adjust the brake assembly to achieve adequate braking. Tighten the clamp screws (B) firmly after adjustment.

The pressure of the pneumatic tyres should be checked before use of the wheelchair. The pressure is shown on the tyre and must never be exceeded. In case of a puncture, the tyre may have to be removed from the rim. Press the valve to let all the remaining air out of the inner tube. Remove the tyre off the rim. Repair or replace the inner tube. Put the tyre back on the rim. Inflate the tyre to the required pressure.

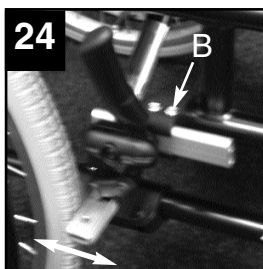

- **Note:** It may be necessary to use one or two tyre removal tools (not supplied). The tyre pressure on both wheels should be the same.

## 17. Amputee kit

Photograph 25

The amputee kit makes it possible for the manually propelled wheelchair to be operated by people whose centre of gravity is further back while allowing the wheelchair to be used with less restrictions than with anti-tippers. The kit should be fitted and adjusted by a qualified technician.



## 18. Tray

Photos 26 and 27

- The tray mounting brackets can be fixed under the armrest pads.

- Use: The tray can be positioned towards the front or back without locking.

The tray can be folded to the left or right for frontal transfers only.

The tray requires no adjustment.

**Note:** Do not move the wheelchair with the tray folded aside.



## 19. Safety Belt

The strap can be adjusted by the user with a buckle system.

A qualified advisor must show you how to position the strap according to your needs.

## 20. Spoke guards

The spoke guards must be assembled by a qualified technician. The spoke guards do not require any adjustment.

## 21. Tipping Levers

Photograph 28

The tipping lever can only be used by an attendant and it is designed to assist tipping the chair rearwards when obstacles are encountered, such as pathway kerbs.

The tipping lever tubes are fixed into the rear tubes of the both side frames (A).

Fit the tipping lever into the side frame rear tube, until the button springs (B) are positioned in the holes of the rear tube (A).

- Use: The attendant, whilst pulling the wheelchair push handles must press on the tipping levers with either foot, in order to raise the front of the wheelchair to the required height.

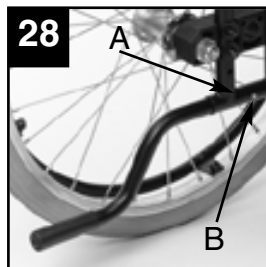

## 22. Routine checks and maintenance

### Checking performance

As a user, you are the first to notice that your wheelchair is not operating properly. The following table shows some readily identified symptoms and gives the preliminary checks to be carried out. As a general rule, the parts subject to wear should be monitored and changed most often: tyres on the rear wheels, front castor wheels, brake pads, upholstery.

The wheelchair drags to the right	The wheelchair drags to the left	The wheelchair turns or moves slowly	The castors wobble	Creaks and clicking	Play in the chair	Checks
X	X	X				Check that the tyre pressure is correct and even
		X	X	X	X	Check that Nuts, bolts and screws are tight
X	X	X				Check that the angle of the front forks is correct
X	X		X			Check that the castors are both in contact with ground at the same time

If the symptoms persist when the tyre pressure has been corrected and the nuts, bolts and screws have been tightened, consult your approved INVACARE distributor.

### Checking the general condition

For maintenance operations, consult your distributor who has all the necessary information.

Twice a year, ask your distributor to inspect your wheelchair thoroughly and carry out in depth maintenance. Regular maintenance allows defective or worn parts to be identified and improves the normal operation of your wheelchair.

The following table shows what to check when the wheelchair is delivered, each week, each month and at 6 monthly intervals.



### Checks to be made

	On delivery	Weekly inspection/adjustment	Monthly inspection/adjustment	6 Monthly Service
<b>1. General</b>				
The wheelchair unfolds and folds easily . . . . .	X			X
The wheelchair moves in a straight line (no resistance or drag) . . . . .	X	X		
<b>2. Manual brakes</b>				
The manual brakes do not touch the tyres when moving . . . . .	X	X		
The manual brakes are easy to operate . . . . .	X		X	
The articulations are not worn and do not show signs of play . . . . .	X		X	
<b>3. Cross bars</b>				
Examine them to check that they are not worn or bent . . . . .	X		X	
<b>4. Clothing protectors / armrest upholstery</b>				
Check that all fixings are in position and tightened . . . . .	X		X	
<b>5. Armrests</b>				
Firmly attached but easy to remove . . . . .	X		X	
<b>6. Arm pads</b>				
Check that the padding is in good condition . . . . .	X		X	
<b>7. Seat and backrest upholstery</b>				
Check that it is in good condition . . . . .	X	X		
<b>8. 22" and 24" wheels</b>				
Wheel nut and sealed bearings correctly tightened . . . . .	X	X	X	
No excessive lateral movement or binding when they are lifted from the ground and turned, quick release axles correctly locked . . . . .	X		X	
<b>9. Handrims</b>				
Check for rough patches . . . . .	X		X	
<b>10. Spokes</b>				
Inspect the spokes in case any are bent, broken or slack . . . . .	X	X		
<b>11. 6" or 8" castors</b>				
Check the axle to ensure that it is correctly tightened, by turning the caster The caster should stop gradually . . . . .	X	X		
<b>12. Fork / Fork tube</b>				
Check that all the fittings are in place . . . . .	X	X		
<b>13. Pneumatic and solid tyres</b>				
If the wheelchair has pneumatic tyres, check that they are correctly inflated (the pressure is shown on the sidewall) . . . . .	X	X		
If the wheelchair has solid tyres, check the running surface . . . . .	X	X		

## 23. Transport

Invacare always advises that a wheelchair secured in a vehicle will not provide the equivalent level of safety and security of vehicle seating systems and recommends transfer to the vehicle seating, but also recognises that it is not always practical for the user to be transferred.

In those cases where it is considered that the user must be transported whilst within the wheelchair, then the following advice should be followed.

1. Seek confirmation from the Transporter that the vehicle is suitably designed and equipped to transport a passenger seated in a wheelchair.

Note: The wheelchair user safety during transportation largely depends upon the diligence of the person securing the tie downs and passenger restraints.

2. Any part of the wheelchair (accessories etc.) that can be easily detached should be removed and stored in the vehicle luggage hold during transportation.

3. The wheelchair should always be transported in a forward facing direction. Rearward facing is only acceptable if the occupant's head and back can be supported by a suitable bulkhead.

4. If the wheelchair is equipped with a headrest, it should always be used during transportation.

5. Invacare recommend that the wheelchair be secured by 4-Point webbing tie down systems as manufactured by Unwin Safety Systems or Koller Safety Restraint Engineers.

6. When attaching tie downs to the wheelchair it is imperative these are fixed onto the MAINFRAME of the wheelchair and not onto any attachments or accessories ( wheels, handrims, castors, footrests, anti tipping levers etc.)

7. The tie downs should be secured, as close as possible, at an angle of 45 degrees to ensure maximum effectiveness of the restraint in all directions.

8. The occupant should be restrained independently of the wheelchair by a suitably Approved passenger safety belt or harness. Pelvic restraint or lap belts supplied with the wheelchair may be used in addition to but never as a substitute for Approved passenger restraints.

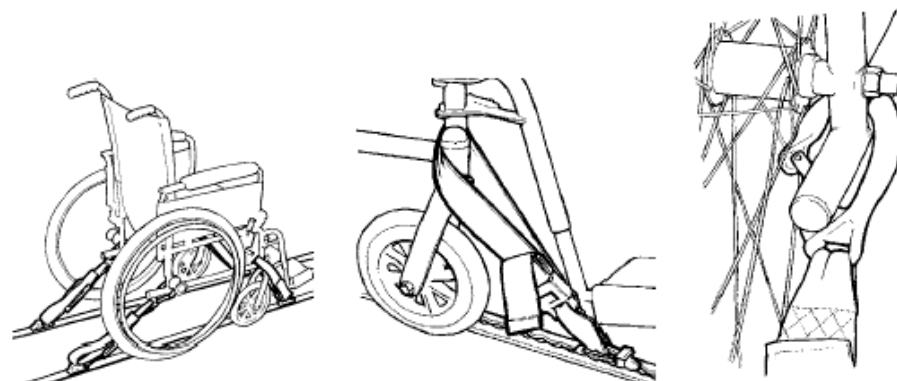

## 24. Guarantee

### Contractual guarantee

This is to certify that your Zipper 2 wheelchair is warranted by Invacare, for a period of 5 years for the frame and crossbars and 18 months for all other parts. This warranty is subject to the following conditions:

1. Only Invacare wheelchairs purchased at full price are warranted against defective workmanship and materials.
2. If a defect or fault is discovered the supplier from whom the appliance was purchased/obtained should be notified immediately.
3. The manufacturer will not accept responsibility for damage caused by misuse or the non-observance of the instructions set out in the User Manual.
4. During the period of the warranty, any parts that have become defective due to faulty workmanship or materials, will be renewed or repaired free of charge by the Invacare supplier.
5. The warranty will be forfeited should any unauthorised alteration be made to the equipment.
6. The purchaser's statutory rights under the Consumer Protection Act are not affected.

### Limitation of liability

This warranty does not extend to the consequential costs resulting from fault clearance, in particular freight and travel costs, loss of earnings, expenses, etc.

Invacare shall not be liable for:

- natural wear and tear
- inappropriate or incorrect use
- defective assembly or setting-up by the purchaser or third parties
- defective or neglectful treatment
- use of unsuitable spares

## 25. Storage

When you will not be using your wheelchair for a prolonged period, the following precautions will help to keep it in perfect condition.

Store the wheelchair in a clean, dry place.

Do not put heavy objects on top of it.

Cover it with a dust sheet to keep it dust-free.

## 26. Cleaning

The parts of the wheelchair can be cleaned with a soft, dry cloth.

Vynyl or Nylon seat and backrest upholstery and the tyres can be cleaned with a cloth dampened in clean soapy water.

When you have been out or whenever the metal parts have been wet, they should be wiped dry to prevent possible corrosion.