



**CE**<sub>1023</sub>

# **Automatic Noninvasive Express Screening Analyzer (ANESA)**

Operating Manual/ User's Manual

Kharkiv, Ukraine  
December 2012

## TABLE OF CONTENTS

General information	3
Models of ANESA	4
Technical data of ANESA (in general, by models)	5
Function of the ANESA	10
Software USPIH	11
Software installation	12
Connecting Analyzer to a computer	14
General safety rules for Analyzer using	19
Functional test for Analyzer. Preparing to use	20
Starting work with USPIH: personal settings	21
Working with the software	24
Description of measuring procedure	32
Counting the number of surveys (for limited versions of ANESA)	38
Troubleshooting	39
Maintenance of the analyzer	40

## General Information

**Automatic Noninvasive Express Screening Analyzer (ANESA) doesn't replace biochemical laboratory analysis and gives the information about more than 100 parameters of human organism. The quantity of certified parameters varies in different countries. Other parameters are used as recommended ones (the list of approved parameters is available upon a request to the regional distributor and the manufacturer).**

Principle of function of Automatic Noninvasive Express Screening Analyzer (ANESA) is based on measurement of temperature in certain biologically active points of a human body, taking into account other initial data about the patient and parameters of environment. All the information is processed by the software USPIH and is the base for the report/survey with more than 100 parameters of health state.

Device has five sensors, which are to be placed onto so-called biologically active points of patients' body.

Bioactive or so-called reference-points used during examination, are following:

- Bifurcation of the right and left neck artery (two points)
- Right and left armpit (two points)
- Umbilical area (one point)

Prior to examination, the five sensors are to be placed onto patient, and the personal data of him, breath rate and pulse rate are to be input to PC from the keyboard. Then measuring, data collecting and processing by the software starts.

Intended fields of the application of the device: clinics, medical research centers, private and family doctors, sanatoriums and other medical institutions.

**Attention! Before use of the system you have to read carefully the USER'S MANUAL to understand function of the system!**

**The system can be used by doctors only! Training courses for users are obligatory!**

## Models of ANESA

ANESA analyzer is manufactured in different enclosures to meet customer needs and requirements. Depending on used enclosure, there are different complete sets of cables with microprocessors. Enclosures are shown on picture2.

Models where one cable with 5 microprocessors is included into complete set of the ANESA Analyzer



**ANESA-L/2007, ANESA-L/2007w**

Models where 5 separate cables, (each with one microprocessor) are included into complete set of the ANESA Analyzer

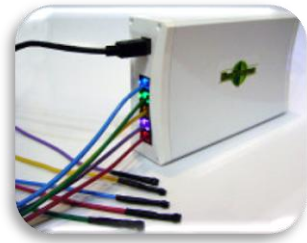

**ANESA -L/2012, ANESA-L/2012w**



**ANESA-T/2009**



**ANESA-T/2011**

*Picture 2. Models of Automatic Noninvasive Express Screening Analyzer (ANESA)*

## Technical data of ANESA

General technical data for all models of ANESA are the following:

PC mains voltage	230 V $\pm$ 10 %; 50/60 Hz
Analyzer's mains voltage (from USB port)	U = 5 $\pm$ 1 V DC I = 95 mA
Consumption	max. 0,475 VA
IP Class	II
Protection of patient	A
EMC	in accordance with EN60601-1-2-2002
IP Class of Analyzer	IP 20
Readiness time counted from switching on	max. 3 min
Range of temperature of reference points	24 – 42 $\square$ C
Margin of error of reference points	max. $\square$ 0,75 $\square$ C
Length of cables for sensors	min. 1,5 m
Accuracy of the sensors	$\pm$ 0,5 $\square$ C, from -10 $\square$ C to +85 $\square$ C
Resolution of the sensors	0.0625 $\square$ C Resolution is user-configurable to 12 bits
Time of examination	max.730 sec
Method of diagnostic:	Malykhin-Pulavskiyi (data collection from reference point)
Software	USPIH (based on methodology of Malykhin-Pulavskiyi)

Minimum hardware requirements:

Processor	Pentium 4, and higher
RAM	min. 512 Mb
HDD	40 GB
Display	min. SVGA 14"…17" definition 1024x768 pixels
USB port	min. 3

Minimum software requirements:

Operating system	Windows XP, 2003, 2008, Vista, 7 <i>During installation of software USPIH, a user must have administrator rights of access.</i>
Antivirus software	Any antivirus software must be set up in such a way, when the software USPIH isn't blocked.

Temperature and pressure sensors are specially tested before assembling by manufacturer.

After switching on Analyzer runs self-test program, to inspect readiness of the software.

**Models ANESA-L/2007 and ANESA-L/2007w** are performed in rigid plastic case. Complete set of this model includes:

Name of	ID	Quant.
Analyzer ANESA	ABDA.941320.001	1
Cable with 5 microprocessors	ABDA.941320.002	1
Key Guardant Stealth II	ABDA.941320.004	1
Cable USB	ABDA.941320.003	1
User's manual/Operating Manual	ABDA.941320.001 PЭ	1
Packing case	ABDA.941320.005	1

Dimensions: 160x100x45 mm

Weight: 0,35 kg (including cable)



- 1 – Connector for a cable, which connects Analyzer with computer
- 2 – Connector for a cable with 5 microprocessors
- 3 – Indicator of power supply and state of a cable with 5 microprocessors
- 4 – A cable with 5 microprocessors
- 5 – Key of software protection Guardant Stealth II

**ANESA-L/2007** – requires software USPIH, version 10

**ANESA-L/2007w** -- requires software USPIH, version 9

Differences in software's versions are described in the part "Software USPIH" (pg.11)

**Models ANESA-L/2012 and ANESA-L/2012w** is performed in white glossy plastic case. Complete set of this model includes:

Name of	ID	Quant.
Analyzer ANESA	ABDA.941320.001	1
Cable with microprocessor	ABDA.941320.002	5
Cable USB	ABDA.941320.003	1
User's manual/Operating Manual	ABDA.941320.001 PЭ	1
Packing case	ABDA.941320.005	1

Dimensions: 200x116x47 mm

Weight: 0.55 kg (including cables)

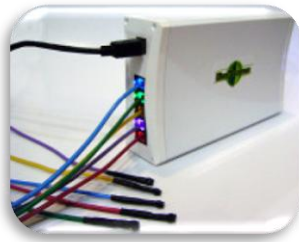

ANESA-L/2012 overview

- Analyzer,
- cables with microprocessors

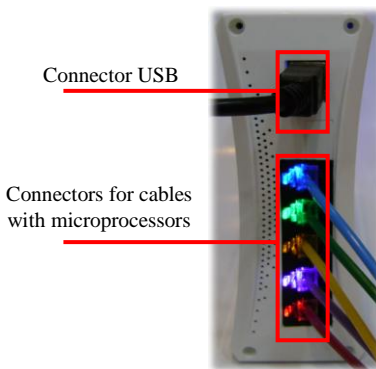

Front panel of Analyzer

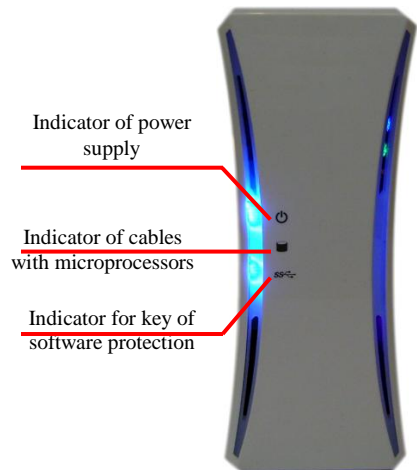

Back panel of Analyzer

**ANESA-L/2012** – requires software USPIH version10

**ANESA-L/2012w** – requires software USPIH, version 9

### Model ANESA-T/2009\*

This model of ANESA is performed together with Tablet PC.



Dimensions: 270x256x35.3 mm Weight: 1.75 kg (including cables and batteries)

Tablet PC is manufactured in Taiwan (Twinhead Corp.). The Tablet PC has been certified in Europe by its manufacturer (CE/FCC, Medical-grade

Class B EN 60601-1/EN60950).

The Analyzer and the Guardant Stealth II key are built inside Tablet PC.

*\*This model isn't manufactured from November, 2011 because the supplier of the Tablet PCs stopped their production.*

### Model ANESA-T/2011

The new generation of Analyzer is performed together with new Tablet PC, made in Taiwan (IEI Corp.).

Tablet PC is slim and compact. It has handle design for easy carry, antibacterial housing and touch-screen monitor. Tablet PC can be used with or without docking station.

The model has got 10.4" TFT XGA LCD, Intel Atom D525 dual core platform, powered by Windows 7 Embedded, dual mode input (digitizer+Multi-Resistive Touch), barcode and RFID readers, smart-card and fingerprint readers, Wi-Fi, Bluetooth.

Dimensions: 270x265x29 mm

Weight: 1.79kg (including cables and batteries)

Analyzer ANESA

Cables  
with microprocessors





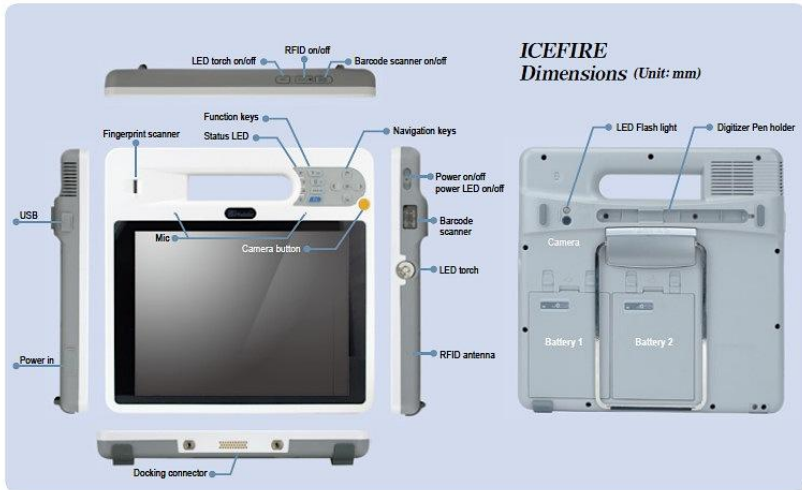

## Indicators

- Green light shows Wi-Fi® is enabled
- Blue light shows Bluetooth® is enabled
- Orange light shows that Battery-1 is being charged
- Orange light shows that Battery-2 is being charged

## Hot Keys

- 4-direction keys (UP, DOWN, LEFT, and RIGHT), and ENTER key
- Wi-Fi on/off button
- Bluetooth on/off button
- Secure Attention Sequence (SAS): identical to "CTRL-ALT-DEL" keystroke combination.

## Function Key Combinations



Model ANESA-T/2011 is available with software USPIH version 10.

## Function of the ANESA

Automatic Noninvasive Express Screening Analyzer processes signals coming from sensors placed on body of a patient, converts these signals to digital form, passes them to the PC and operates then.

Five sensors connected to analyzer measure temperature of patients' reference points with accuracy not less than 0,5°C. Sensors send parameters of temperature to central processor unit of the ANESA Screening Analyzer. Given data are processed by central processor unit and are sent to PC, which makes it possible to view and print the results. Calculation of the data of blood test parameters is made by special examination algorithm named Malychin-Pulawski method (Ukrainian Patent Nr. 3546 A61B5)

Connection points of sensors	
<i>Bifurcation of left artery - Blue</i>	<i>Bifurcation of right artery – Green</i>
<i>Left armpit (axillaries) - Yellow</i>	<i>Right armpit (axillaries) - Violet</i>
<i>Abdominal area (umbilicus) - Red</i>	

An examination will take 3-10 minutes. The interval depends on a patient, could be control and changed during examination by a doctor.

There is no harmful influence of the Analyzer to a patient during examination; Analyzer determines the influence of environment to a patient's health.

At the end of an examination a doctor will receive the report with 124 parameters which includes parameters of functional and hemodynamic balance, gaseous homeostasis, cardio-vascular system, central autonomic nervous systems, respiratory and enzyme systems, etc. Besides, there will be a prompt for a doctor about diagnosis at the end of a report. It is not a final diagnosis.

**Only the doctor can set the final diagnosis!**

The doctor studies all the information: received report, patient complaints, any previous results (e.g. laboratory analysis, ultrasonography, tomography, etc.) and preliminary diagnoses from the report. On the base of general analysis, the doctor can set final diagnosis.

## Software USPIH

"USPIH" installation software is supplied by Internet and can be downloaded from the link, mentioned by the manufacturer in the technical Passport to the Analyzer. Prior to use the Analyzer, it is necessary to install the software to PC. During installation the new directory will appear on hard drive, containing following files (C:\Program Files\USPIH 10):

- USPIH.exe – real time control application;
- USPIH\_EN.chm – help;
- PATIENT.FDB– database files;
- update.exe – software update application;
- DBConverter.exe – database converter application;
- FTDI directories – PC interface drivers files;
- Other files necessary for operation of interface drive.

Nowadays, the manufacturer offers two versions of the USPIH software: version 9 and version 10.

Main features of the both types of software are the following:

Features	Version 9	Version 10
Local module of mathematical processing	-	+
Server module of mathematical processing	+	-
Billing of measurements	+	-
Restrictions of operability according to the territory of usage	+	-
Local database	+	+
Reports are generated in SGS units	+	+
Reports are generated in SI units	+	+
Multilanguage interface	+	+
Graphical display of the measurement process	+	+
Automatic update	-	+
Manual update	+	+
Internet access for processing of measured data	+	-

## Software installation

**1. Analyzers with Tablet PC (ANESA-T/2011, ANESA-T/2009) are equipped with pre-installed USPIH 10.**

**2. Analyzers ANESA-L/2007 and ANESA-L/2012 require the installation of software USPIH, version 10. The way of installation is the following:**

2.1. Before installing the software USPIH make sure that your computer has two free USB ports and you have got the rights of "Administrator» (Windows Vista, Windows 7).

2.2. Download the installation software using the appropriate link, mentioned in the Technical Passport for your device and run it.

2.3. Select the language for the installation and click "OK":



2.4. In the appeared window, click „Next”:



2.5. In the appeared window, tick „Create a desktop icon” and click „Next”:



2.6. Press “Install”:



Please wait until the software is installed on your computer.

2.7. If the software is installed for the first time, **do not launch** it after installation (because the drivers for the device has been not installed yet):



At the end, an icon  will appear on your desktop.

## Connecting Analyzer to a computer

1. Usually, the drivers of ANESA install automatically, if you start the process in the following way:

1.1. Connect the cable with five microprocessors (ANESA-L/2007) or 5 cables, each with one microprocessor, (ANESA-L/2012) to the device Analyzer;

- Connect USB cable to your Analyzer;
- Connect USB cable to your computer.

Following screen will appear:



In case of any mistakes with connecting or any special features of OS on your computer, the drivers will not be installed and the following message will appear:

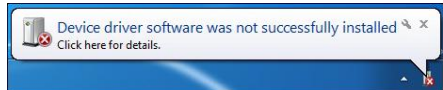

Click the left mouse button on above icon

In the appeared window, click "Close."

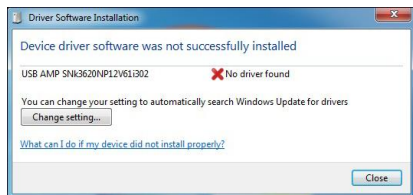

Open Device Manager:

Click Start on the desktop and type «Device manager» in "Search" window... Open Device Manager

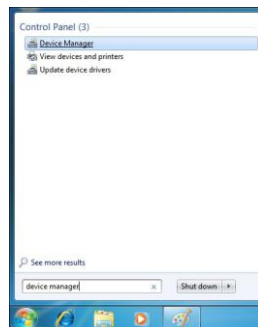

There is the name of your device in the list of "Other devices". It is necessary to click the right mouse button on yellow exclamation mark before the name of the device and select "Update Driver":

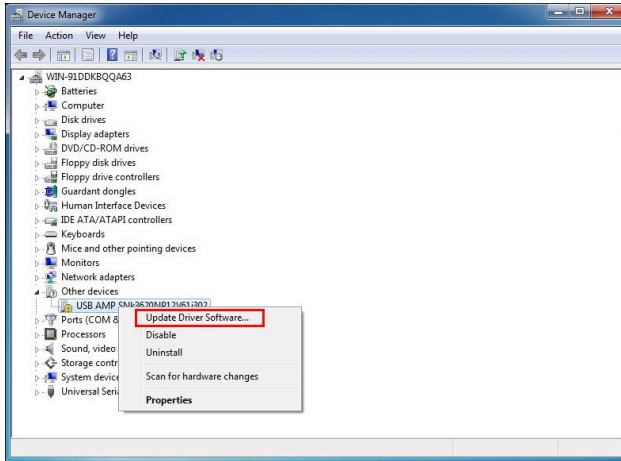

Click the "Browse my computer for driver software".

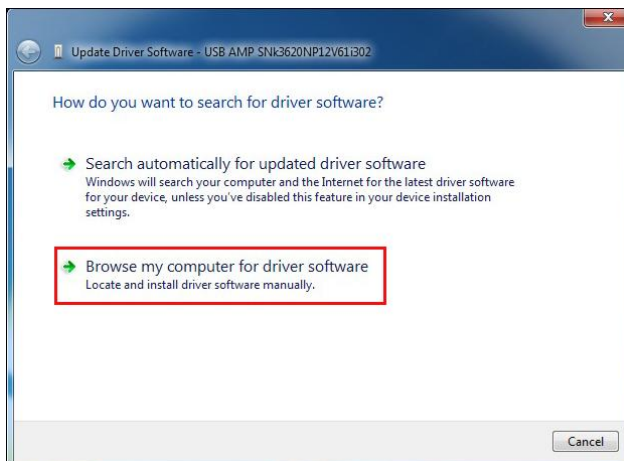

Specify the path to the drivers of the ANESA, which (by default) are located in the folder "C:\Program Files\USPIH\_10" (tick "Include subfolders"). Click "Next".

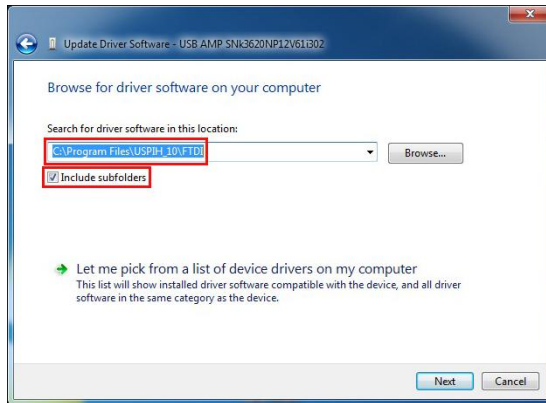

In the appeared window click „Install this driver software anyway”.

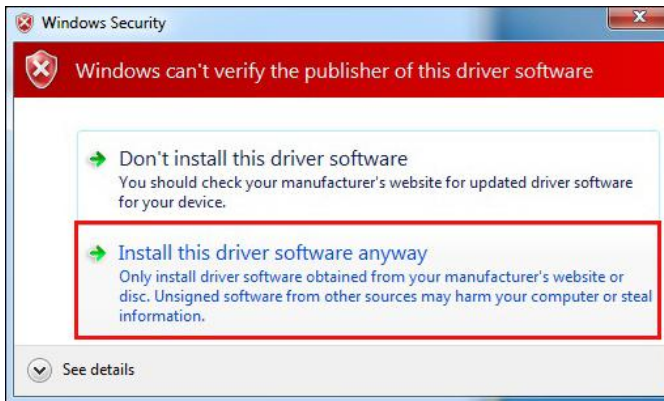

Wait until ANESA drivers are being installed.

If the drivers' installation is successful, the following message will appear:

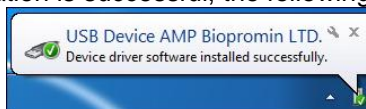



The model **ANESA-L/2007** requires **Guardant Stealth II key** for working. After connecting the Analyzer and successful installation of its driver, it is necessary to connect Guardant Key to your computer. Windows OS will detect it and install the drivers automatically. The following window will appear:

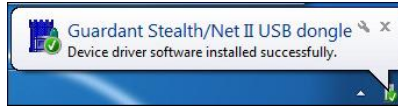

In case of any incorrect installation of drivers, please do the following:

Open "Control Panel"

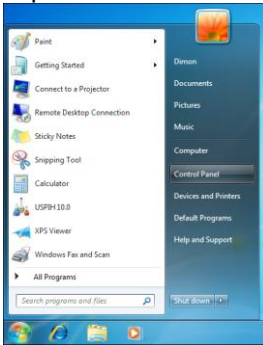

Choose "System"



Choose advanced system settings

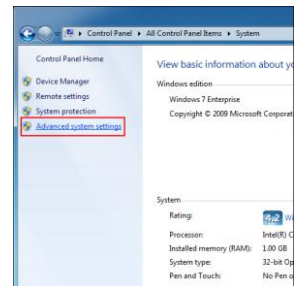



Choose Hardware tab and  
Device Manager

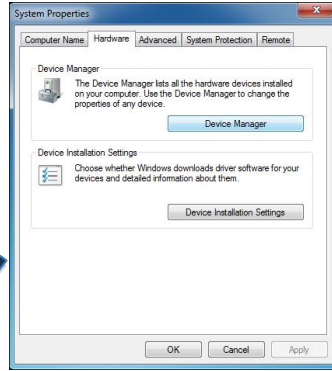

Check if both key entries  
are listed

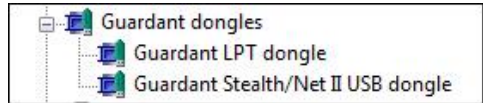

If only LPT device is listed, please contact the official service.

## General safety rules for Analyzer using

### It is prohibited to use the analyzer if:

- ambient temperature is higher than + 27°C or lower than +20°C;
- relative humidity more than 80%, at 25 °C;
- atmospheric pressure less than 620 or higher than 760 mm Hg;
- aggressive vapour present in the air;
- dusty spaces;
- direct sunshine;
- strong electric and magnetic fields present;
- moist environment

### During operation and maintenance of the system, the following safety measures shall to be kept:

- a) It is prohibited to use the analyzer in case of damaged cable isolation.
- b) Before usage, make a visual inspection of analyzer for detecting any possible broken and torn parts, or other mechanical damages.
- c) Avoid the analyzer against moisture condensation. In case of fast ambient temperature change, allow at least 30 minutes to evaporate the moisture.
- d) Power cable of PC shall have protective ground wire, and the plug shall have ground connection, and shall be conform with mains socket.
- e) Data processing units connected to device (Model ANESA-L/2007, ANESA-L/2007w, ANESA-L/2012, ANESA-L/2012w) shall be used with safety transformer which shall meet requirements of standard MSZ:60601-1/1997 related to medical devices (e.g. ST-200 transformer made by Standel Ltd.).
- f) Do not twist the mains cable and place it in such a way, to avoid its damage.
- g) It is prohibited to use aerosols and liquids for cleaning the device.
- h) Always place the analyzer on stable and solid surface.
- i) It is prohibited to use the analyzer in tinderbox, e.g. in room where flammable sleeping-draughts are kept.

### Cleaning and disinfection of Analyzer

**Attention!** Prior to cleaning and disinfection of analyzer's surface, all the cables shall be removed from Automatic Noninvasive Express Screening Analyzer (ANESA) sockets.

**Attention! Disinfection of the surface and patient cable by aggressive chemicals or solvents (phenol-based chemicals, ester, benzene, propanol, chloroform or acetone is PROHIBITED.**

**Attention! Disinfection of analyzer and its accessories by heated air is PROHIBITED.**

Wipe enclosure of analyzer by soft wet cloth dipped to soapy water and well squeezed.

Avoid analyzer against getting in the liquid inside during cleaning and disinfection of analyzer enclosure.

**Disinfection of sensors must be made by alcohol (96%) or alcohol wipes. Do not wipe sensor by cloth as it may cause scratches on its surface.**

**To provide life expectancy of analyzer, cables and sensors, it is PROHIBITED:**

- to bend cables of sensors and PC;
- to remove sensors from patient pulling the cables, or to pull cables from sockets;
  - to wipe surface of sensors, clean them, or use any solid, abrasive materials for cleaning.

The device does not contain poisonous substances. The exploitation of the device complies with the general safety measures.

Before use of the device must be withdrawn from parts of the valuable substances.

The device set of parts and materials to be used in accordance with prevailing legislation

### **Functional test for Analyzer**

A doctor needs to make functional test for the Analyzer everyday when starts working with it. It is necessary to check if the device works properly. The procedure is the following:

- Prepare the analyzer as it is described on pg.22;
- Create a new patient with the name TEST (pg.32). It is created just once; further a doctor can use the same record for functional test.
- Fill in required information about TEST patient: any figures in the allowed ranges can be used;

- Keep all sensors in the hand (the measuring surface of sensors should touch skin);
- Start measurement and wait while it is completed;
- If the parameters are displayed at the end and a survey is generated, the device worked and can be used. In case of any troubles, appeared errors, etc., find the solutions on pg.40 or contact the distributor.

### **Preparing to use the Analyzers Model ANESA-L/2007, ANESA-L/2012**

- Connect the cable with 5 microprocessors or each cable with microprocessor to the appropriate connector on the Analyzer's front panel.
- Connect USB cable to Analyzer and computer. It is desirable that the computer was turned off at the same time.
- Turn on your computer.
- Run the software USPIH.

The analyzer is ready for use.

### **Preparing to use the Analyzers Model ANESA-T/2009, ANESA-T/2011**

- Connect each cable with microprocessor to the appropriate connector on the Analyzer's front panel.
- Connect the Analyzer to the appropriate socket on the tablet PC.
- Turn on your tablet PC (according to the instructions of PC's manufacturer)
- Run the software USPIH

Working with the Analyzer is the same for all models of ANESA. When the Analyzer is ready for a work and software USPIH is run, it's time to start measurement. The process of measurement is described in detail in the next part "Description of measuring procedure" (pg.24).

### **Starting work with USPIH: personal settings.**

1. Run USPIH, clicking on the icon on the desktop or Start button on bottom of Windows tools, and then, select the USPIH program from "All programs" menu list:
2. First time, the program will run in English. If you need to change the language to another one, chose appropriate language in the top menu:

### 3. Setting up the template for surveys. Open setting tag, using the icon

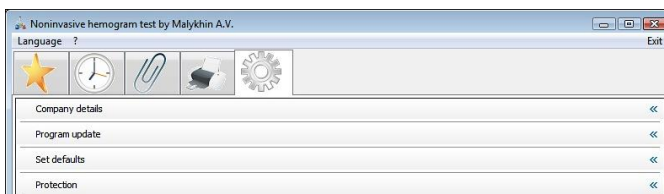

3.1. It is possible to add and format the name of a company, it's address and contact information, as well as a company's logo in the **“Company details”** menu: four spare fields are used for the details and one more – for logo.

**Logo image** (click "Browse" and select a picture) must be in **\*.bmp** format and its size cannot be smaller than 40x40 pixels.



### 3.2 Software update settings (**“Program update”** menu)

Software is updated through Internet automatically every 30 days (by default). It is possible to change the period of software's updating. In case of necessity of manual updating, click the button "Check for Update."

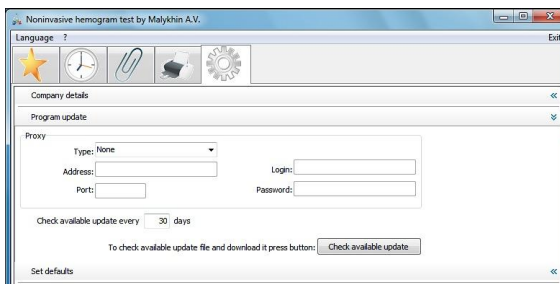

You can follow up the process of updating on the bottom toolbar of your PC

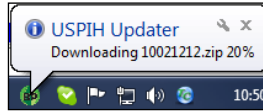

It is necessary to close the software USPIH after finishing the process of updating:

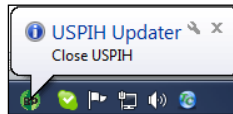

Launch of updated USPIH software will be made automatically.

3.3. To decline a customer's settings and return the setting set by the manufacturer, use the menu "Set defaults". All settings will be returned to the initial ones.

3.4. To prevent unauthorized deleting of patients' records and surveys from the database, you can activate the protection of the USPIH software with a password. It is possible to do, using "**Set protection**" menu.

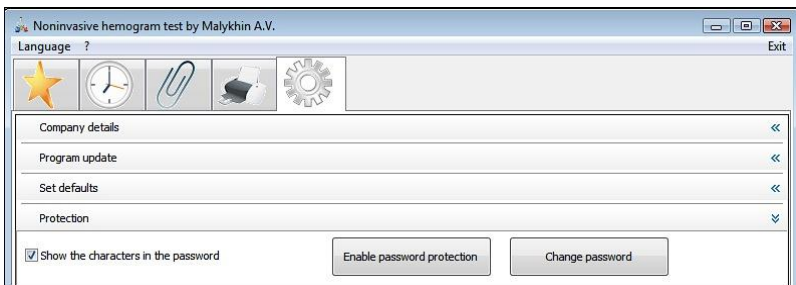

To display the characters in the password checkbox, tick "Show characters in the password"

To enable or change the password, press an appropriate button.

The following window will appear:



Enter a password, using 4-8 characters. The default password is "0000" (four zeros).

In case of changing the password, it is necessary to enter the old password and confirm it by pressing the button "Yes." Then, a new password should be entered and confirmed by pressing the button "Yes" (the procedure should be made twice). If the changing of a password is successful, the message "Password is changed successfully" will appear.

## Working with the software

### 1. Description of USPIH software interface

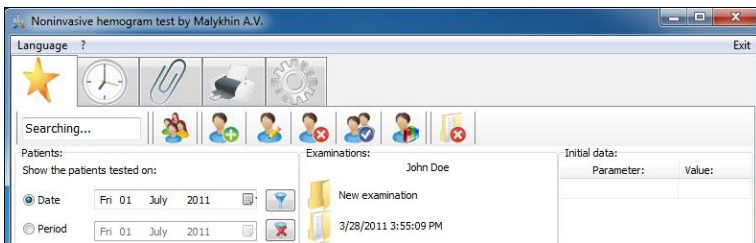

#### 1.1 The top menu contains three sub-menus

##### **"Language"**

to choose/change the language

##### **"?"**

to open help file and information about program

##### **"Exit"**

to exit the program

#### 1.2. The second-level menu consists of 5 markers:





main window/  
starting  
window



graphic trends  
and checking  
panel for  
temperature  
measuring



results of  
measurement



generating of  
the results for  
printing or  
saving



settings  
window

### 1.3. The third-level menu contains searching box and several icons.

*Search Box* – is intended for searching patients or patients' groups. It is necessary to enter the initial letters (minimum 3) of a patient's name or group name and the program will offer patients and groups containing the similar combinations of letters.



Groups  
of  
patients



Add a  
new  
patient



Edit a  
patient's  
data



Delete a  
patient  
from  
database



Merge  
surveys  
of  
patients



Dynamic  
changes of  
selected  
parameters



Deleting of  
a patient's  
survey  
from  
database

*Detailed description of each sub-menu from the 3d-level is on the pg.27-31*

### 1.4. The main window of the software includes the following information:

#### *A list of patients/groups*

- ❖ Filter for selecting patients according to the date of examination: it is possible to choose the exact date of an examination or the possible period of time, when the examination could be done.

Patients:  
Show the patients tested on:

Date    Fri 01 July 2011    [calendar icon]    [filter icon]

Period    Fri 01 July 2011    [calendar icon]    [cancel icon]

TEST (1)

Filter is activated after pressing the

- ❖ icon

Filter becomes non-active after

pressing the icon

Thu 09 June 2011    [calendar icon]    [filter icon]    [cancel icon]

June 2011

Mon	Tue	Wed	Thu	Fri	Sat	Sun
30	31	1	2	3	4	5
6	7	8	9	10	11	12
13	14	15	16	17	18	19
20	21	22	23	24	25	26
27	28	29	30	1	2	3
4	5	6	7	8	9	10

Today: 09/06/2011

- ❖ Part “Examinations” shows existing surveys for a chosen patient and/or icon “New examination”, which can be used for a new test (*description for a new examination creating is on the pg.32*).

Patients:		Examinations:	
Show the patients tested on:		John Doe	
<input checked="" type="radio"/> Date	Fri 01 July 2011		New examination
<input type="radio"/> Period	Fri 01 July 2011		3/28/2011 3:55:09 PM
			6/8/2011 8:53:01 AM
			6/8/2011 2:23:40 PM
TEST (1)			
John Doe			

- ❖ Part “Initial data” concerns the selected examination of the patient and contains the initial information about the patient, measured temperatures, air pressure and temperature stabilization:

Examinations:		Initial data:	
Jane Doe			
	New examination	Parameter:	Value:
	02/02/2011 17:21:41	Sex:	female
	04/02/2011 11:18:11	Age:	77
		Weight:	77
		Pulse:	77
		Resp.rate:	18
		LCA:	31.1
		RCA:	30.63
		LAC:	30.38
		RAC:	30.76
		ABD:	30.34
		Atm.pres:	753.65
		Stabilizing:	99999

Stabilizing “99999” means the temperatures during measurement fully stabilized (100%).

Stabilizing “00000” concerns opposite situation, temperatures didn't stabilize during measurement.

**IMPORTANT! FOR CUSTOMERS, WHO USED USPIH ver.6 and START USING USPIH ver.10!**

Old software (USPIH ver.6) didn't contain information about stabilization of temperatures. That's why, after converting database version 6 to version 10, the stabilization will be displayed as “00000”.

## Patient's groups

For the convenience of usage, the patients in database can be divided

into groups. It is necessary to use icon  for creating a new group, editing or deleting an existing one.

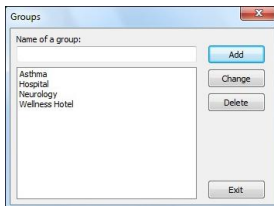

**IMPORTANT!** The software USPIH 10 will not permit the existence of two groups with the same title.

## Add/Edit/Delete a patient and/or examination

Adding, editing and deleting of patients can be done in two ways: using the icons from the 3d-level menu or using the context menu (right click by mouse on the list of patients/selected patient). Used icons are the same in both ways.

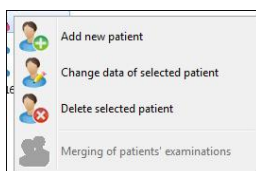

To **Add** a patient, press appropriate icon and fill in the required data

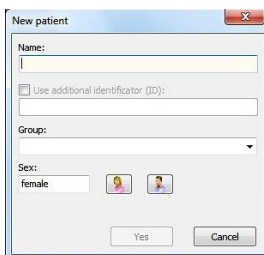

It is necessary to input the name and surname of a patient, choose the group and gender in the appeared window.

In case you need to input additional identifier for the patient, it's necessary to tick the appropriate window and add identifying information (e.g. ID, passport, social number, etc.).

You can select an existing group from the drop down list or enter the name of a new group. If the name of group is new in the database, the group will be created automatically. You can leave the field "Group" blank. In this case, the patient's record/card will be placed in general list of the database and will be displayed after all groups of patients.

For gender selection (male or female), click the appropriate button.

After confirmation of adding a new patient (button "Yes"), the patient's card will be displayed in appropriate group or general list.

To **Edit** the information of an existing patient, it is necessary to select the patient and press appropriate icon in the main or context menu 

**IMPORTANT!** If you change the gender of the patient, then all his/her surveys will be changed/recalculated automatically.

To **Delete a patient's card**/record from the database, it is necessary to select the patient's card from the list of patients and then click an appropriate icon in the main or context menu 

In case the password protection is activated, enter the valid password in the appeared window (the default password is "0000" (four zeros)).

**Merge** surveys of patients 

The program USPIH 10 allows combining of patient's surveys under the same name. It is useful in case the same patient was added to the database several times (with differences in the name or surname, e.g. John Doe, John D. J. Doe). So his or her surveys can be merged under single name. This option is available just for patients with the same gender. It can be done in the following way:

- scroll to the patient's survey, which you want to combine;
- hold down the button «Control» (Ctrl) on the keyboard and select another patient (if necessary, select a few patients);
- click an appropriate icon in the main or context menu

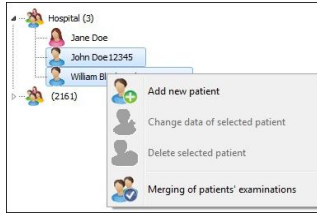

- in the appeared window, select the single name of the patient. Click “Yes” to continue or “Cancel” to exit.

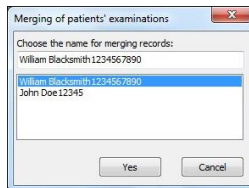

Finally, there will be just one patient with several surveys.

**IMPORTANT!** After the merging of surveys, IT IS IMPOSSIBLE TO DIVIDE them back to its original state!

## Dynamic changes of selected parameters

This option allows displaying the dynamic changes of selected parameters (graphically) for a patient, who was examined several times. For that purpose, it is necessary to choose the patient from the list and press appropriate icon in the menu.



The following window will appear:

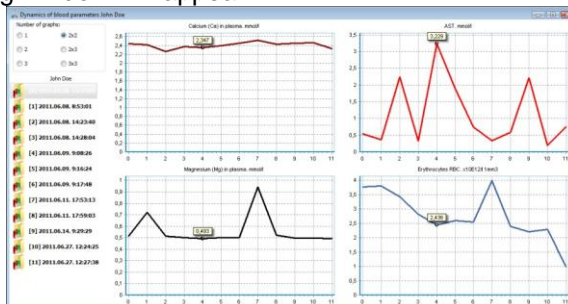

In the “number of graphs”, you can choose the number and location of diagrams:

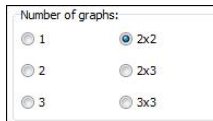

To add required parameters to each diagram field, it is necessary to put the cursor on a field of diagram and call context menu (mouse right click). In the drop-down list, select the group and then the parameter.

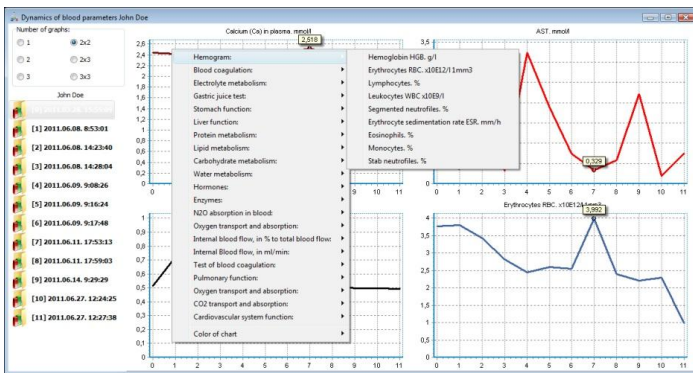

X-axis on the graph shows the index number of an examination, Y-axis shows the value of chosen parameter.

When the cursor is on the dynamic curve, the value of parameter in admitted point is displayed in pop-up hints.

By default, all examination of the selected patient are represented in the list of examinations for comparison. They are displayed in the left part of the window. To exclude an examination from the list, click the left mouse button on the date of the survey you don't need.

Color of curves can be chosen from the drop-down list of parameters (at the end of list). The selected color is automatically saved.

To exit the menu, press „X” in upper right corner.

**Deleting of patients survey from the database** can be done in the following way:

- Select the examination, you'd like to delete, from the list and click appropriate icon in the main menu . Right-click on the examination also allows choosing the same operation "Delete Selected survey."
- In case of password protection is activated, enter the valid password in the appearing window (the default password is "0000" (four zeros)).

### New patient examination

Select a patient from the list of database in the main window and click the icon "New Examination":

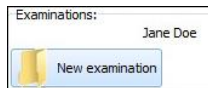

In the window that appears, enter the initial data of the patient:

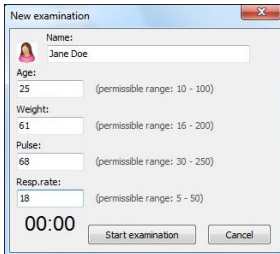

<i>Data</i>	<i>Units</i>	<i>Description</i>	<i>Valid range</i>
<i>Age</i>	<i>years</i>	number of full years	10-100
<i>Weight</i>	<i>kg</i>	weight of a patient in kilograms	16-200
<i>Heart rate/Pulse</i>	<i>beats/min</i>	number of heart beats per 60 sec	30-250
<i>Respiration rate</i>	<i>Insp/min</i>	number of inspiration per 60 sec	5-50

Try to determine heart rate very carefully! If you have problems with the definition of rate (especially with 100 or more beats per minute), we recommend you to use heart rate monitor manufactured by POLAR (Finland).

You can find the stopwatch in the bottom left corner, which can help you during measurement of heart and breath rates. Just click on the stopwatch  and it will start working. Second click will stop and resets the stopwatch.

## Description of measuring procedure

The work begins with adding a new patient (pg.27-28) or choosing the existing one from the database and creating the new examination (pg.31)

Five microprocessors (sensor) should be placed on the "reference" points (after a preliminary degreasing the skin and disinfection of sensors with alcohol wipes):

- **Blue** - in the area of the carotid artery bifurcation (on the external and internal) on the left side, in the area of cricoid (LCA);
- **Green** - in the area of the carotid artery bifurcation (on the external and internal) on the right side, in the area of cricoid (RCA);
- **Yellow** - on the left armpit in axillary area (LAC);
- **Purple** - on the right in axillary area (RAC);
- **Red** - in the abdominal area (umbilicus) (ABD).

Running the data by pressing the "Start measurement" in program USPIH. Information processing takes 180-720 seconds, depending on a patient's state.

The program goes to the window with graphic trends and checking panel for temperature measuring. A doctor follows up the process of measurement and controls if the process is going in right way. It is evidenced by the promotion of progress bar and temperature graphs:

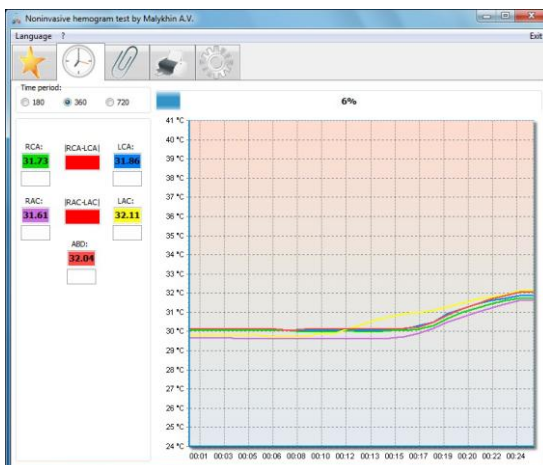



The interval of measurement can be 180, 360 or 720 seconds (by default 360 seconds). It can be changed during an examination in the "Time period" menu



or in drop-down menu, which appears after right-click on the progress bar. The measurement can be stopped using this menu, as well:

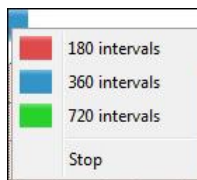

**IMPORTANT!** The accuracy of the results of an examination on the ANESA depends on the accuracy of temperature measurements in the reference points. Because of this, a software interface includes visual indicators, which help a doctor to determine the time of temperature stabilization and control the process of measurement.

The indicators are the following:

RCA: 28.17 <b>a</b>	RCA-LCA  0.00 <b>f</b>	LCA: 28.17 <b>b</b>
RAC: 28.30 <b>c</b>	RAC-LAC  0.13 <b>g</b>	LAC: 28.17 <b>d</b>
	ABD: 28.23 <b>e</b>	

- a** - an indicator of temperature stabilization on the right side of carotid artery bifurcation
- b** - an indicator of temperature stabilization on the left side of carotid artery bifurcation
- c** - an indicator of temperature stabilization in the right armpit (in axillary area)
- d** - an indicator of temperature stabilization in the left armpit (in axillary area)
- e** - an indicator of temperature stabilization in the abdominal area (umbilicus)
- f** - indicator of the temperature difference between left and right side of carotid artery bifurcation
- g** - indicator of the temperature difference in armpits

At the beginning of measurement all indicators are red. After 30 seconds the software starts to analyze temperature stabilization.

The color of indicators a, b, c, d, e varies from red (the temperature is not stable) to green (the temperature stabilized) during the process of stabilization. Each indicator shows the process of stabilization of an appropriate sensor.

RCA:	RCA-LCA	LCA:	RCA:	RCA-LCA	LCA:
29.86	0.19	30.05	28.17	0.00	28.17
RAC:	RAC-LAC	LAC:	RAC:	RAC-LAC	LAC:
29.98	0.06	29.92	28.30	0.13	28.17
	ABD:			ABD:	
	30.29			28.23	

Temperature is considered stable, if it doesn't change more than 0.15°C during 40 seconds.

Indicator **f** shows the temperature difference between bifurcation points of left and right carotid arteries; usually it should not exceed 0.5°C.

Indicator **g** shows the temperature difference between left and right armpit, usually it should not exceed 0.5°C.

**IMPORTANT!** Indicators **f** and **g** are very important for a doctor during test. They are used as control instruments and give the information if the test is going right, if chosen time interval is enough for testing.

If the difference between armpit sensors does not exceed 0.5°C, as well as carotid sensors, and temperature of all sensors (including sensor of abdominal area!) stabilized, the indicators become green, otherwise - red.

**IMPORTANT!** If the lights are not green at the end of the measurement, a doctor should change time interval for testing to larger one.

During every measurement, "floating window" will appear on temperature graph. The "floating window" has red border, if the stabilization of temperatures is not reached. When temperatures stabilized, the "floating window" becomes green.

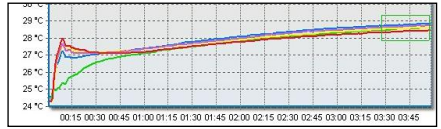
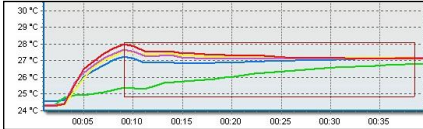

This is another important control point during measurement for doctors.

It is possible to zoom the graph by selecting the necessary area with a mouse. To return the graph to its original position hold the left mouse button and drag it across the field chart from right to left.

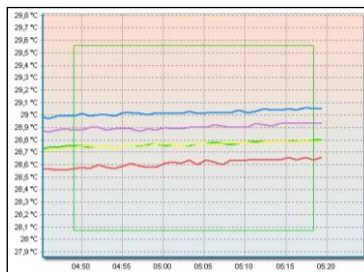

When the measurement is finished, the next window „Results of measurements” opens automatically.

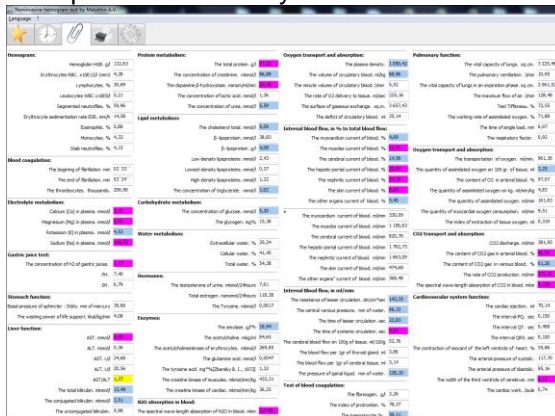

- **Red** color of field means that the parameter is higher or lower than the generally accepted norms;
- **Blue** color of field means that the parameter complies with generally accepted norms;
- **White** color of field means that the parameter is not compared with the normal ranges by the software;
- **Yellow** color of field attract a doctor's attention to the parameter.

When a doctor put the cursor to any value of parameter, the pop-up hint with normal ranges for this parameter will be displayed.

Program USPIH allows generating of surveys in two types of units: SI or SGS. To choose/change the units, use right-click on the examination of a patient (you'd like to preview) and select the required units:

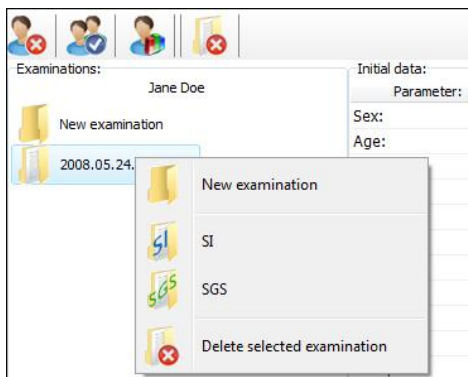

**IMPORTANT!** Remember, there is no person in nature, whose parameters fit to generally accepted normal ones. The norms were defined for average person (with average weight, height, age etc.). Statistical estimation was done on relatively small population in a limited area many years ago.

To generate the surveys for printing or saving, please use the appropriate





icon . A printout editor will appear. There is an automatic conclusion for a doctor to help with diagnosing a patient at the end of survey. The

doctor can agree with it or edit it/delete something from it. It is possible to not print the conclusion at all (use click near window with conclusion).

No.	Parameter	Norm	Value
<b>Hemogram</b>			
1	Hemoglobin (Hb), g/l	120 - 160	135.04
2	Erythrocytes (RBC, $\times 10^{12}$ /l)	3.4 - 5	4.04
3	Lymphocytes, %	19 - 37	27.66
4	Leukocytes (WBC) $\times 10^9$ /l	3.2 - 10.2	2.07
5	Segmented neutrophils, %	47 - 72	43.03
6	Erythrocyte sedimentation rate ESR, mm/h	2 - 20	28.63
7	Stomatohly, %	0.2 - 1.0	6.92
8	Monocytes, %	3 - 11	3.06
9	Stab. neutrophils, %	1 - 6	15.04
<b>Blood coagulability</b>			
10	The beginning of fibrinolysis, min	0.5 - 2	62.39**
11	The end of fibrinolysis, min	3 - 5	02.24**
12	The fibrinolytic, fibrinolytic, fibrinolytic	100 - 200	200.24
<b>Electrolyte metabolism</b>			
13	Calcium (Ca) in plasma, mmol/l	2.25 - 3	2.46
14	Magnesium (Mg) in plasma, mmol/l	0.7 - 0.99	6.52
15	Potassium (K) in plasma, mmol/l	3.46 - 5.2	4.04
16	Sodium (Na) in plasma, mmol/l	120.5 - 156.4	145.11
<b>Genetic juice tests</b>			
<p>It is the laboratory.</p> <p>It is necessary to determine an impaired coagulation. The blood coagulability must be under control.</p> <p>It is necessary to get a consultation of a gastroenterologist (gastroenterologist). It is necessary to eliminate a pathology of small intestine.</p> <p>It is necessary to get a consultation of a gastroenterologist (gastroenterologist). There is the pathology of small intestine.</p> <p>There is the pathology of small intestine. There is the pathology of small intestine.</p> <p>It is recommended to test blood on glucose level.</p> <p>There is the special investigation. There is the investigation of water electrolyte metabolism. The Ca of plasma is changed (Ca of urine tests).</p> <p>It is diagnosed the reduction of of any vitamins. Fermentative activity (gastric tests) (ammonia, albuminuria). It is necessary to eliminate the ga.</p> <p>There is the hypochromia of these coagulation.</p> <p>The form (parameters are possible, Magnesium (Mg) in plasma, mmol/l=0.32 Calcium (Ca) in plasma, mmol/l=2.46)</p> <p>The result of the first control of coagulation, mmol/l.</p>			

On the right bottom corner there is a field for notes (e.g. patient's history, results of additional tests, prescribed medicines etc.), which can be used by a doctor on his/her own.

**IMPORTANT!** Remember, only a doctor can set final diagnosis for a patient! The program's conclusion is generated based on the list of diagnoses stored in the software; software does not know all the nosologies!

There is the possibility to hide some parameters/group of parameters for printing version (use the icon  and/or  for that purpose; ticked parameters will be printed out).

To save the edited survey as html-file, click on the icon . File will be generated for saving; the name of file will contain the name of a patient, date and time of examination).

To print out the survey click on the icon 

## Counting the number of surveys (for limited versions of ANESA)

According to distributor's requirements, Guardant Stealth II Secured key can limit software (version 10). The limited version of the software allows examining definite (previously programmed) quantity of patients.

The distributor makes updating of limits or upgrading to unlimited versions.

Any user of limited version of the software is able to control the remaining quantity of tests. Such information is displayed in help menu (use icon "?" in the top menu and choose "About software"):





Number of remaining tests is mentioned in the last sentence. In case the software is unlimited, the icon of infinity "∞" will be displayed there.

**IMPORTANT!** If the number of remaining tests becomes zero, it will be impossible to examine anybody. To update the limit of examinations, please contact the distributor.

## Troubleshooting

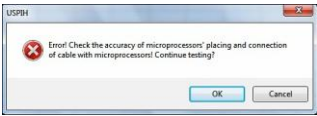
Possible errors and solutions:

	Error/problem	Reason	Solution/advice
1	<b>Software doesn't run</b>	Guardant Stealth key isn't connected to PC	Check if the Guardant Stealth key is connected to PC. Reconnect it.
		Guardant Stealth key drivers were installed incorrect	Green LED on Guardant Stealth key isn't lighting. Check the drivers for Guardant Stealth key (process is described on pg. 17-18).
2	<b>Measurement couldn't start</b>	There is no connection between cable with sensors/sensor and ANESA	Check the LED on ANESA (enclosure). The LED will be blinking, - if there is bad connection between appropriate cable with sensor and ANESA; - if appropriate cable with sensor is damaged.
		Any of sensor is damaged	
		Sensors are not placed on a patient's body or placed incorrect 	Place the sensors, and then click "OK". The window may appear again, if the measured temperature is below 24°C or above 41°C
3	<b>Device ANESA isn't found</b>	There is no connection between ANESA and PC	Check USB cable, which connects ANESA and PC: connect/reconnect it or replace USB cable, in case of damage.
		Drivers for the device were installed incorrectly	Check the drivers and reinstall them
4	<b>Examination isn't completed</b>	Invalid examination will be marked by special symbol. The program will automatically suggest deleting "invalid examination". It should be deleted.	 2011.06.15. 9:35:09

## Maintenance of the Automatic Noninvasive Express Screening Analyzer (ANESA)

Staff of a user, in accordance with timetable, provides maintenance of the analyzer.

### Maintenance of the non-invasive screening analyzer

Item	Timetable		
	everyday use	after storage	after transportation
Function test (pg.20)	daily	+	+
Visual inspection of analyzer, connections, cables and sensors for damages	daily or if required	+	+
cleaning of analyzer (pg.20)	daily	+	+
periodic inspection by the manufacturer/authorized service center	annually and after repair	-	-

**Manufacturer** makes the warranty repairs:



#### **Biopromin Ltd.**

Ukraine 61038 Kharkiv, Khalturina str. 50, tel.: +38-057-732-52-05

e-mail: [bioluch@yahoo.com](mailto:bioluch@yahoo.com)

or the authorized service centres.

### Authorized representative in European Union:

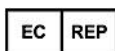

#### **Onkocet Ltd.**

4 Kutuzova str., 90201 Pezinok, Slovakia, tel.: 421 244 64 09 77

Tel. (Russian, German, Slovakian, Czech) +421 948 610 228

Tel. (English, Hungarian, Slovakian) +421 903 114 944

e-mail: [onkocet@onkocet.eu](mailto:onkocet@onkocet.eu)

All valid permissions and certificates are placed on the manufacturer's homepage

[www.anesa.tc](http://www.anesa.tc)

Last revision: December 10<sup>th</sup> 2012