

---

**User's  
Manual**

**YTA70**  
**Temperature Transmitter**

**YTA** SERIES

IM 01C50C03-01E

---

**vigilantplant™**

# CONTENTS

---

<b>1. MODEL AND SUFFIX CODES .....</b>	<b>1</b>
<b>2. WARRANTY .....</b>	<b>1</b>
<b>3. HANDLING PRECAUTIONS .....</b>	<b>2</b>
<b>4. STANDARD SPECIFICATIONS.....</b>	<b>2</b>
<b>5. BLOCK DIAGRAM .....</b>	<b>4</b>
<b>6. WIRING .....</b>	<b>4</b>
<b>7. SAFETY APPROVALS .....</b>	<b>5</b>
7.1 CENELEC ATEX(DEMCO) Intrinsically safe model .....	5
7.2 FM Intrinsically safe model .....	6
<b>8. HART COMMUNICATION .....</b>	<b>7</b>
8.1 Connection and Requirements .....	7
8.2 Parameters .....	8

## ◆ REVISION RECORD

The YTA70 is a head mount type of temperature transmitter that accepts thermocouple or RTD input and converts it to a 4 to 20 mA DC signal for transmission. The YTA70 specifies HART communication protocol for remote configuration.

It is imperative that users observe the instructions in this manual to ensure the protection and safety of operators.

## 1. MODEL AND SUFFIX CODES

Model	Suffix code	Descriptions	
<b>YTA70</b>	.....	Temperature Transmitter	
Output Signal	<b>-E</b> .....	4 to 20mA DC with digital communication (HART protocol)	
Optional Specifications	<b>/KS2</b>	CENELEC ATEX intrinsically safe approval	EEx ia IIC T1-6 Amb. Temperature T1-4: -40 to 85°C (-40 to 185°F), T5-6: -40 to 60°C (-40 to 140°F)
	<b>/DS2</b>	CENELEC ATEX/FM intrinsically safe approval combination	CENELEC: EEx ia IIC T1-6 FM: IS Class I, Div.1, Groups A, B, C & D

T01E.EPS

## 2. WARRANTY

The warranty period of the instrument is as of condition shown when purchasing. Any trouble arising during the warranty period shall be replaced at free of charge. The following problems or troubles shall not be eligible of charge-exempt repair.

- Caused by improper usage or storage of the customer which exceeds the specification requirements.
- Caused by mishandling or modification.
- Caused by fire, earthquake or other acts of God that are not directly a result of problems of the instrument.

### 3. HANDLING PRECAUTIONS

- (1) Read this manual thoroughly and carefully before handling the instruments. Observe the instructions.
- (2) Store the product in location that meets the following requirements.
  - No exposure to rain or water
  - No major mechanical vibration or shock
  - Humidity and Temperature limitations
  - Ordinary conditions(25°C, 65%) is preferable.
 Otherwise, as of specified in “Standard Specifications.”
- (3) Avoid corrosive atmosphere for storage and installation.
- (4) For safe installation of the transmitter in hazardous area, the following must be observed. The module must only be installed by qualified personnels who are familiar with the national and international laws, directives, and standards that apply to this area.

### 4. STANDARD SPECIFICATIONS

#### Accuracy (see table below)

Sensor type	Standard	Input ranges		Minimum span		Accuracy (value whichever is greater)
		°C	°F	°C	°F	
<T/C>						
B	IEC584	400 to 1820	752 to 3308	200	360	± 0.1% of span or ±1.0°C
E		-100 to 1000	-148 to 1832	50	90	
J		-100 to 1200	-148 to 2192	50	90	± 0.1% of span or ±0.5°C
K		-180 to 1372	-292 to 2502	50	90	
N		-180 to 1300	-292 to 2372	100	180	
R		-50 to 1760	-58 to 3200	200	360	± 0.1% of span or ± 1.0°C
S		-50 to 1760	-58 to 3200	200	360	
T	-200 to 400	-328 to 752	50	90	± 0.1% of span or ± 0.5°C	
L	DIN43710	-100 to 900	-148 to 1652	50		90
U		-200 to 600	-328 to 1112	75	135	
W3	ASTM	0 to 2300	32 to 4172	200	360	± 0.1% of span or ± 1.0°C
W5		0 to 2300	32 to 4172	200	360	
<RTD>						
Pt100	IEC751	-200 to 850	-328 to 1562	10	18	± 0.1% of span or ± 0.1°C
Ni100	DIN43760	-60 to 250	-76 to 482	10	18	± 0.1% of span or ± 0.2°C
DC Voltage		-800 to 800 [mV]		2.5 [mV]		± 0.1% of span or ± 0.01mV
Resistance		0 to 7000 [Ω]		25 [Ω]		± 0.1% of span or ± 0.1Ω

T02E.EPS

#### Cold Junction Compensation Accuracy(For T/C only)

±1°C(±1.8°F)

## **Ambient Temperature Effects (per 10°C Change)**

For E, J, K, L, N, T and U thermocouple inputs:

$\pm 0.05\%$  of span or  $\pm 0.25^\circ\text{C}$ , whichever is greater

For R, S, B, W3 and W5 thermocouple inputs:

$\pm 0.05\%$  of span or  $\pm 1^\circ\text{C}$ , whichever is greater

For Pt100 and Ni100 RTD inputs:

$\pm 0.05\%$  of span or  $\pm 0.05^\circ\text{C}$ , whichever is greater

For DC voltage input:

$\pm 0.05\%$  of span or  $\pm 5\mu\text{V}$ , whichever is greater

For Resistance(ohm) input:

$\pm 0.05\%$  of span or  $\pm 0.05\Omega$ , whichever is greater

## **Power Supply Effects**

$\pm 0.005\%$  of FS per Volt

## **RFI Effects**

Tested per EN 61326, field intensity up to 10 V/m.

## **EMC Conformity $\text{CE}$**

Emission:EN50 081-1, Immunity:EN 61326

## **Maximum Zero Offset**

$\pm 50\%$  of the maximum temperature

## **Input Signal Source Resistance (for T/C input)**

10 M $\Omega$ , or 3 k $\Omega$  at power-off

## **Input Lead Wire Resistance (for RTD input)**

5  $\Omega$  per wire or lower

## **Burnout**

High(NAMUR NE43 upscale) , Low(NAMUR NE43 downscale) or value within 3.5 to 20 mA

## **Output**

Two wire 4 to 20 mA DC

## **Response Time**

1to 60 sec programmable

## **Ambient Temperature Limits (Option code may affect limit)**

$-40$  to  $85^\circ\text{C}$  ( $-40$  to  $185^\circ\text{F}$ )

## **Ambient Humidity Limits**

5 to 90% RH at  $40^\circ\text{C}$  ( $104^\circ\text{F}$ )

## **Supply Voltage**

8 to 35 V DC

8 to 28 V DC for Intrinsically safe type

13.8 to 35V DC for digital communication

## Load Resistance

Limitation: 0 to  $(E-8)/0.0236$  [ $\Omega$ ], where E is power supply voltage.

## Isolation

Input/output isolated to 1500 V AC.

## Mounting

DIN form B head mounting

## Terminals

M3 screws

## Weight

50g(0.11 lb)

## 5. BLOCK DIAGRAM

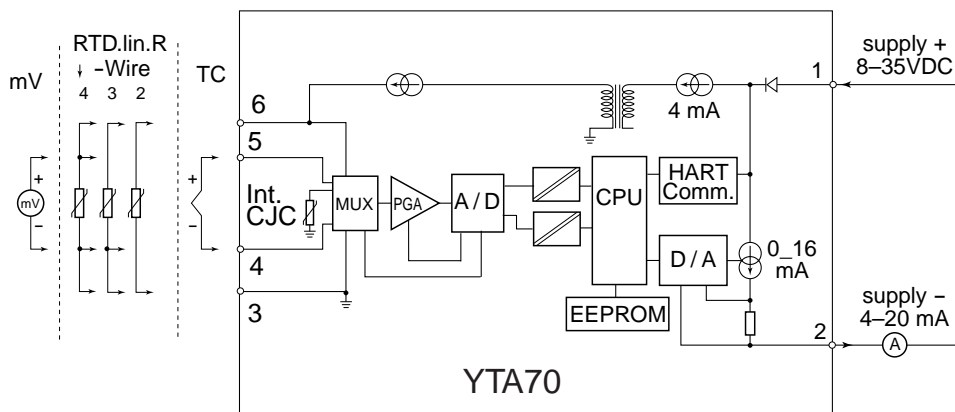

## 6. WIRING

See wiring diagram. For output signal, use twisted pair or cables with performance equivalent to 600V vinyl insulate cable. For wiring in high or low temperature, use a wire or cable suitable for such temperature. Use cables and wires which meet atmospheric conditions. Take necessary measure to avoid corrosion or damage of cables and wires.



### IMPORTANT

When mounting on a sensor head, do not overtighten the screws.

## ■ WIRING DIAGRAM

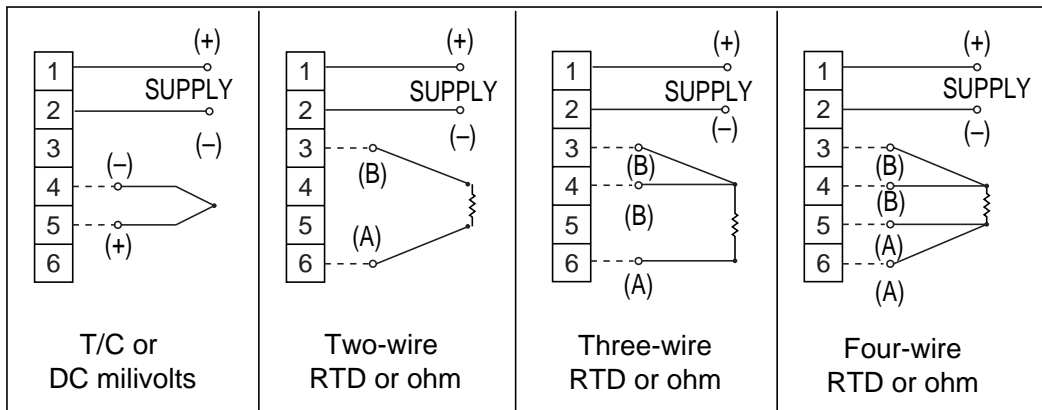

F03E.EPS

## ■ DIMENSIONS

Unit : mm (approx. inch)

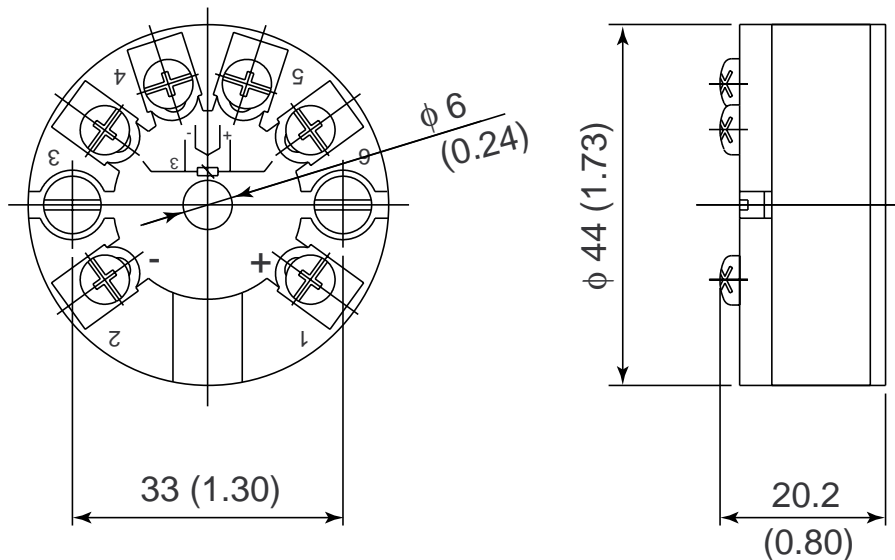

F02E.EPS

## 7. SAFETY APPROVALS

### 7.1 CENELEC ATEX(DEMCO) Intrinsically safe model (/KS2, /DS2)

[ Installation diagram ]

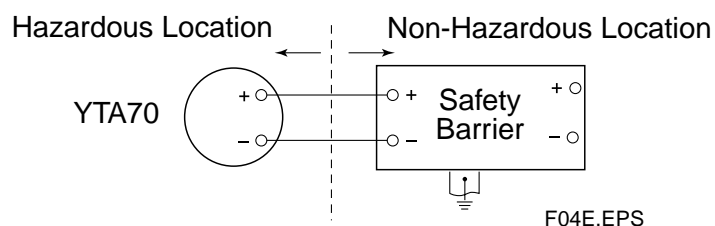

F04E.EPS

## Intrinsically safety rating(maximum value)

Output/Power supply :

$U_i=28V$ ,  $I_i=120mA$ ,  $P_i=0.84W$ ,  $C_i<1nF$ ,  $L_i<10\mu H$

Sensor :

$U_o=28V$ ,  $I_o=93mA$ ,  $C_o<0.12\mu F$ ,  $L_o<2 mH$

## Applicable in Zone

0, 1, or 2

## Maximum Ambient Temperature

For T1-T4: 85°C, For T5/T6: 60°C

## 7.2 FM Intrinsically safe model (/DS2)

### Installation diagram

[ Connection with power supply buit in receiver ]

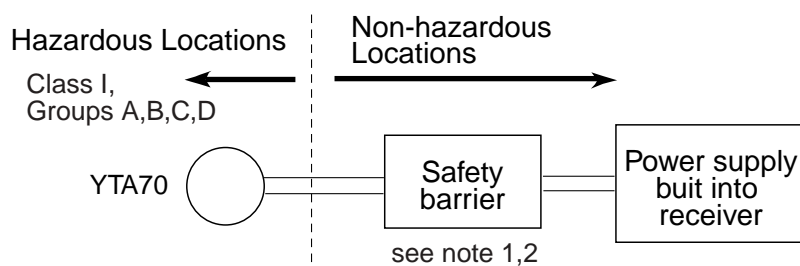

[ Connection with seperate power supply and receiver ]

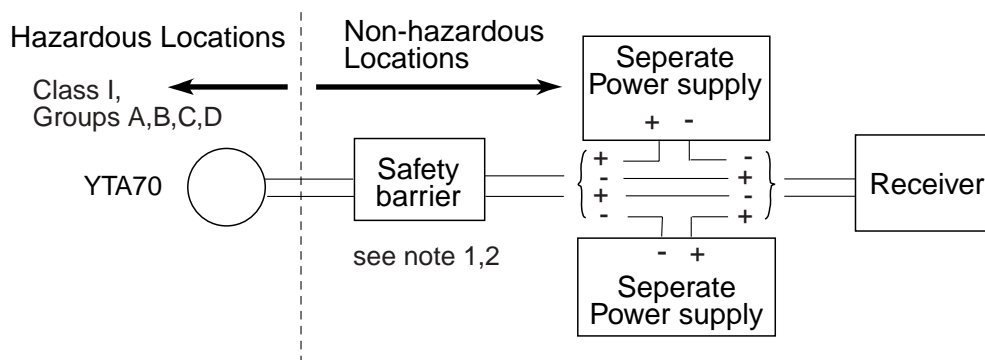

F08E.EPS

## Output

Standard 4 to 20 mA loop

## Note

1. Maximum entity parameters ;  
 $V_{MAX}=28VDC$ ,  $I_{MAX}=120mA$ ,  $P_{MAX}=0.84W$ ,  $C_i<1nF$ ,  $L_i<10\mu H$
2. Maximum power  $P_{MAX}=0.84W$  is limited by the resistor in the barrier.  
If  $V_{OC}=28VDC$ , the resistor shall be more than  $233.3\Omega$ .



# 8. HART COMMUNICATION

## 8.1 Connection and Requirements

A standard HART communicator can be used for programming the YTA70. The HART communicator must be loaded with the appropriate DDL driver for YTA70.

Minimum loop resistance is 250Ω. If the receiving equipment has a lower resistance, a serial resistor must be inserted to communicate with the HART communicator.

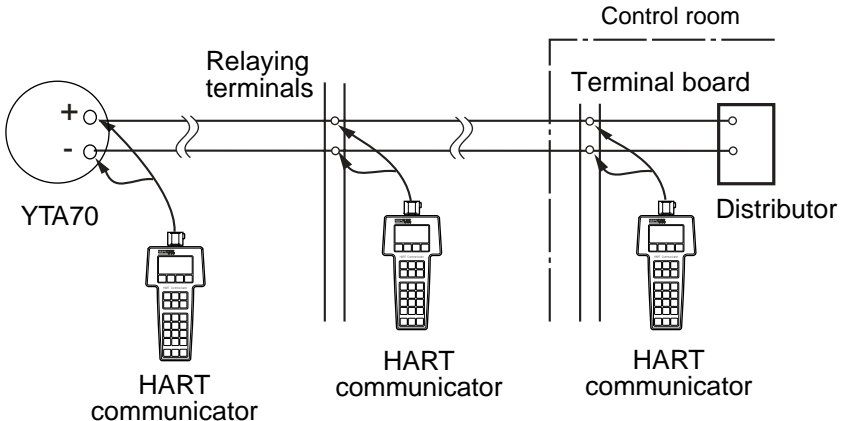

F05E.EPS

### Connection

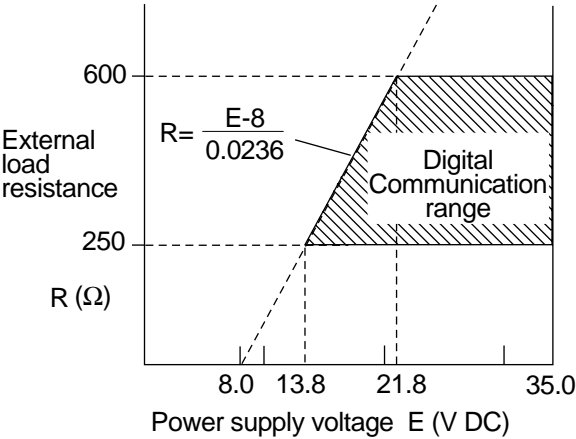

F06E.EPS

### Communication requirement

# 8.2 Parameters

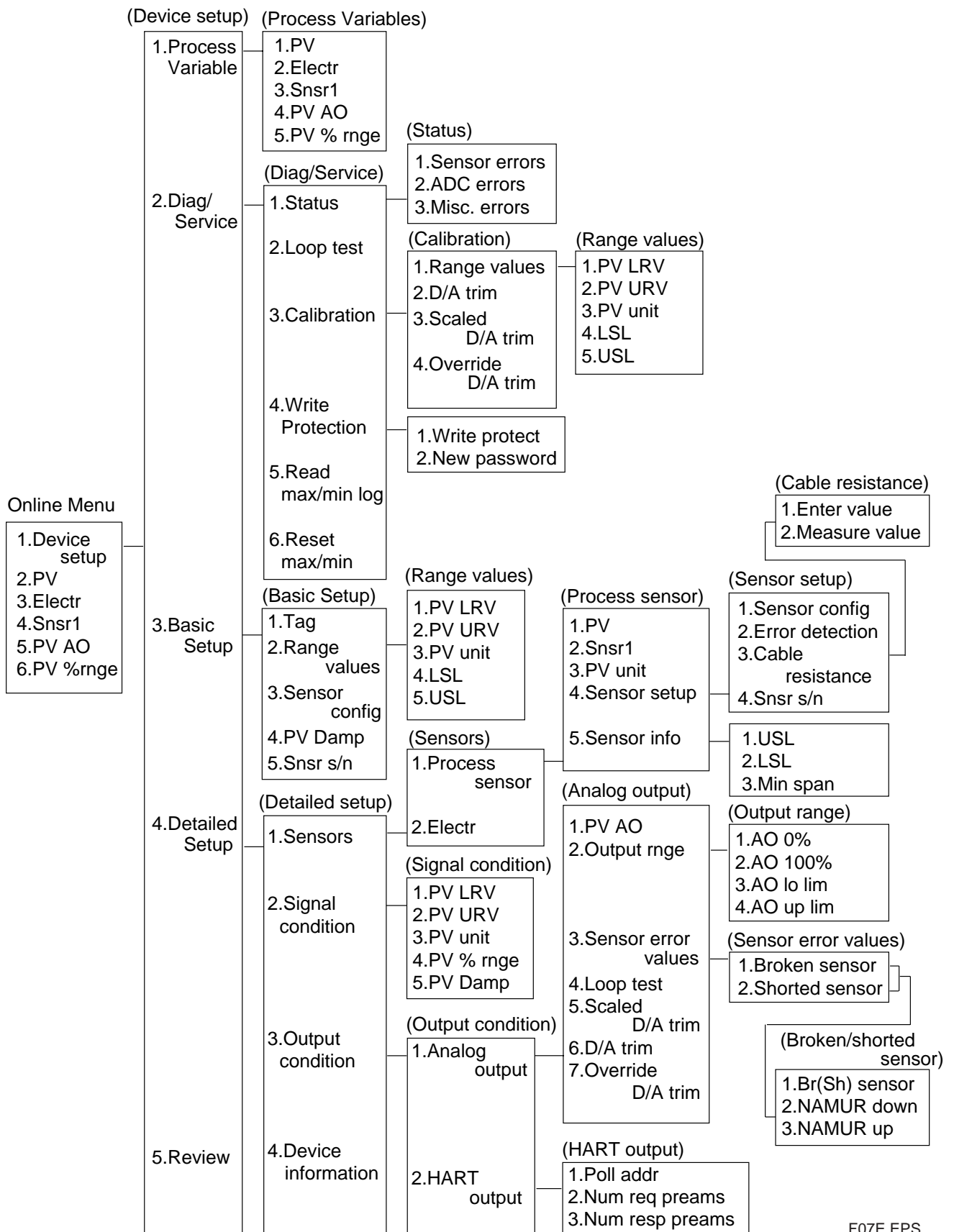

F07E.EPS

## Parameters List(1/3)

Item		HART Communicator	Selection/ Setting Range	Initial Setting
Process Variable	Process Variable	PV	Measured variables in engineering unit.	—
		Electr	Terminal temperature	—
	Output value	PV AO	Output value in mA	—
		PV % rng	Output value with respect to the range in %	—
	PV Log	Read max/ min log	Reads the maximum / minimum PV stored in the memory	—
Reset max/min		Clears the PV maximum / minimum log and restart logging	—	
Signal Condition	Range value	PV LRV / PV URV	Lower / upper range value to defines the 0% /100% value of the measurement	LRV: 0 URV:100 (note1)
	Range Limit	LSL / USL	Shows the max. / min. usable value for upper / lower range value	—
	Unit	PV unit	Engineering unit to be displayed with such digital value as PV, URV, LRV, USL, LSL,min.span, etc.	°C
	Damping	PV Damp	Damping time constant in seconds applied to the digital value. 0 to 62.5(s) [see note in page 11.]	0.43(s) (note1)
Sensor Setup	Sensor config	Sensor type (wire, unit)	Sensor type and related settings. [When T/C or milivots is selected ] Always select "single" for a measurement type. [When RTD or ohm is selected ] Always select 2-,3- or 4-wire but others for the number of sensor wires.	Pt100 3-wire °C (note1)
		RTD factor	For RTD only. Leave it to "1".	1
		Cold Junction Compensation	For T/C only. Always leave it to "1.internal sensor".	Internal sensor
	Sensor Errors	Error detection	Type of sensor errors to be detected for burnout operation. (1)No test performed, (2)broken sensor, (3)shorted sensor, or (4)broken & shorted	broken sensor
	Cable resistance	Enter value	Enter new value of the RTD/ohm cable resistance for compensation.	5 (ohm)
		Measure value	Actually measure the cable resistance of 2-wire RTD/ohm for compensation.	—
	Minimum span limit	Min.span	Minimum settable span	—

Note 1) Or as specified upon ordering.

T03E\_1.EPS

## Parameters List (2/3)

Item		HART Communicator	Selection/ Setting Range	Initial Setting
Output Condition	Analog Output range	AO 0%(100%)	Output value for 0%(100% ) in mA.	4 (0%) 20 (100%)
		AO lo(up) lim	Output lower(upper) limit in mA. NAMUR, or 3.8 to 23mA	NAMUR
		Sensor Error values	Enter or select the output value when sensor error is detected. NAMUR upscale, NAMUR downscale, or value within 3.5 to 23mA	NAMUR upscale [high] (note1)
		Loop test	Change the output manually for testing the loop. 4mA, 20mA, or value within 3.5 to 23mA	—
Diagnos-tics	Error status	Sensor errors	Show error status related to a sensor. When any one of the errors turns "ON", check the sensor and wiring.	—
		ADC errors	Show error status related to analog to digital conversion. When any one of the errors turns "ON", Re-power the device. If error remains, replace the device.	—
		Misc. errors	Show error status related to a device. When any one of the errors turns "ON", Re-power the device. If error remains, replace the device.	—
Calibra-tion	Write protection	Write protect	Write-protects the device, if correct password is entered.(note 2)	Not protected
		New password	Sets a new password for wirte protection, if correct password is entered.	—
	Apply trim	D/A trim	Allows the calibration of a selected analog output with an external reference at the operating endpoint.	—
		Scaled D/A trim	Allows the calibration of the analog output with the external reference which is scaled at 0 to 100%.	—
	Clear trim	Override D/A trim	Overrides any previous D/A trimming by restoring factory calibration values.	—

Note 1) Or as specified upon ordering.

Note 2) The initial setting of password upon shipment is "\*\*\*\*\*".

T03E\_2.EPS

### Parameters list (3/3)

Item	HART Communicator	Selection/ Setting Range	Initial Setting
Device information	Manufacturer	Manufacturer identification code	Yokogawa
	Model	Model name	YTA70-E
	TAG	Tag number, up to 8 alpha-numerical characters.	—
	Descriptor	Text which can be used by user in any way. Up to 16 alpha-numerical characters	—
	Message	Text which can be used by user in any way. Up to 32 alpha-numerical characters	—
	Date	Date information. MM/DD/YY. Not inclemented. The date is updated whenever changing configuration via PC configurator.	Factory calibration date
	Write protect	Indicates whether the device is write-protected.	Not protected
	Snsr s/n	Not used.	0
	Final assembly number	Not used.	0
	Distributor	—	Yokogawa
	Revision #'s	Software/hardware revision number	—
	Status	Error stauts (see "Error status" in this table.)	—
Review	Input info	List of input variables	—
	Output info	List of output variables	—
	Device information	See "Device information" in this table.	—

T03E\_3.EPS



## ◆ Revision Record

---

- Manual No. : IM 01C50C03-01E
- Title : YTA70 Temperature Transmitter

<b>Edition</b>	<b>Date</b>	<b>Page</b>	<b>Revised item</b>
1st	Mar. 1999	—	New Publication
2nd	Jun. 1999	1 6 10	Add code "/DS1" in the table Add "7.2 FM intrinsically safe model" Add "note 2" .
3rd	Feb. 2000	2,3 4 9 11	Revise accuracy & temperature effect. Correct "Isolation". Add explanation Add "Note".
4th	Mar. 2002	1 2	Change Optional code KS1 and DS1 to KS2 and DS2 respectively. Add description(4) based on ATEX directives.
5th	July 2003	1,5,6	Delete code "/KS1" and "/DS1".

---

Written by Product Marketing Dept.

Transmitters Center  
Industrial Automation Systems Business Div.  
Yokogawa Electric Corporation

Published by Yokogawa Electric Corporation  
2-9-32 Nakacho, Musashino-shi,  
Tokyo 180-8750, JAPAN

---

## **YOKOGAWA ELECTRIC CORPORATION**

### **Headquarters**

2-9-32, Nakacho, Musashino-shi, Tokyo, 180-8750 JAPAN  
Fax: 81-422-55-0461

## **YOKOGAWA CORPORATION OF AMERICA, INC.**

### **Headquarters**

2 Dart Road, Newman, Ga. 30265-1040, U.S.A.  
Phone: 1-770-254-0400 Fax: 1-770-254-0928

## **YOKOGAWA EUROPE B.V.**

### **Headquarters**

Vanadiumweg 11, 3812 PX, Amersfoort, THE NETHERLANDS  
Phone: 31-334-64-1611 Fax: 31-334-64-1610

## **YOKOGAWA AMERICA DO SUL S.A.**

Ameria Juruá, 149-Alphaville, Barueri, Sao Paulo, SP, BRAZIL  
Phone: 55-11-7295-1433 Fax: 55-11-7295-1329

## **YOKOGAWA ENGINEERING ASIA PTE. LTD.**

5 Bedok South Rd., Singapore 469270, SINGAPORE  
Phone: 65-241-9933 Fax: 65-241-2606

## **HANKUK YOKOGAWA ELECTRIC CO., LTD.**

K.P.O.Box: 1481, Korean Reinsurance Bldg. 2F, 80 Susong-Dong,  
Chongro-ku, Seoul, KOREA  
Phone: 82-2-3701-0630/0650 Fax: 82-2-739-3987

## **YOKOGAWA AUSTRALIA PTY. LTD.**

Private mail bag 24, Centre Cpoint D3, 25-27 Paul Street North, North Ryde,  
N.S.W.2113, AUSTRALIA  
Phone: 61-2-9805-0699 Fax: 61-2-9888-1844

## **YOKOGAWA BLUE STAR LTD.**

40/4 Lavelle Road, Bangalore 560 001, INDIA  
Phone: 91-80-2271513 Fax: 91-80-2274270 Telex: 81-8458702 YBCO IN