

AC Servo Drive PRONET series User's Manual V. 1.04



Estun Limited Warranty

This manual does not entitle you to any rights. Estun reserves the right to change this manual without prior notice. All rights reserved. The copyright is held by Estun. No part of this publication may be copied or reproduced without written permission from Estun.

General Precautions

Read this manual thoroughly before checking products on delivery, storage and transportation, installation, wiring, operation and inspection, and disposal of the AC servodrive.

WARNING

- Never touch any rotating motor parts while the motor is running.
Failure to observe this warning may result in injury.
- Before starting operation with a machine connected, make sure that an emergency stop can be applied at any time.
Failure to observe this warning may result in injury.
- Never touch the inside of the SERVO DRIVES.
Failure to observe this warning may result in electric shock.
- Do not touch terminals for five minutes after the power is turned OFF.
Residual voltage may cause electric shock.
- Do not touch terminals for five minutes after voltage resistance test.
Residual voltage may cause electric shock.
- Follow the procedures and instructions for trial operation precisely as described in this manual. Malfunctions that occur after the servomotor is connected to the equipment not only damage the equipment, but may also cause an accident resulting in death or injury.
- The multiturn limit value must be changed only for special applications. Changing it inappropriately or unintentionally can be dangerous.
- Do not remove the front cover, cables, connectors, or optional items while the power is ON.
Failure to observe this warning may result in electric shock.
- Do not damage, press, exert excessive force or place heavy objects on the cables.
Failure to observe this warning may result in electric shock, stopping operation of the product, or burning.
- Provide an appropriate stopping device on the machine side to ensure safety. A holding brake for a servomotor with brake is not a stopping device for ensuring safety.
Failure to observe this warning may result in injury.
- Do not come close to the machine immediately after resetting momentary power loss to avoid an unexpected restart. Take appropriate measures to ensure safety against an unexpected restart.
Failure to observe this warning may result in injury.
- Connect the ground terminal to electrical codes (ground resistance: 100 Ω or less).
Improper grounding may result in electric shock or fire.

- Installation, disassembly, or repair must be performed only by authorized personnel.
Failure to observe this warning may result in electric shock or injury.
- Do not modify the product.
Failure to observe this warning may result in injury or damage to the product.
- Always use the servomotor and SERVO DRIVE in one of the specified combinations.
Failure to observe this caution may result in fire or malfunction.
- When replacing the SERVO DRIVE, transfer the previous SERVO DRIVE parameters to the new SERVO DRIVE before resuming operation.
Failure to observe this caution may result in damage to the product.
- Do not attempt to change wiring while the power is ON.
Failure to observe this caution may result in electric shock or injury.
- Do not disassemble the servomotor.
Failure to observe this caution may result in electric shock or injury.

- When disposing of the products, treat them as ordinary industrial waste.

Contents

PRONET SERIES USER'S MANUAL V. 1.04.....	1
GENERAL PRECAUTIONS.....	2
CHAPTER 1.....	5
CHECKING PRODUCTS AND PARTS NAMES.....	5
1.1 CHECK PRODUCTS.....	5
1.2 MODEL DESIGNATION.....	5
1.2.1 Pronet series servo drive.....	5
1.2.2 EMJ series servo motor.....	6
1.2.3 EMG series servo motor.....	7
1.2.4 EML series servo motor.....	8
1.2.5 EMB series servo motor.....	9
CHAPTER 2.....	10
INSTALLATION.....	10
2.1 SERVODRIVE.....	10
2.2.1 STORAGE AND TRANSPORTATION.....	10
2.2.2 INSTALLATION SITES.....	11
2.2.3 INSTALLATION ORIENTATION.....	11
2.2.4 INSTALLATION METHOD.....	11
CHAPTER 3.....	14
WIRINGS AND CONNECTIONS.....	14
3.1 WIRINGS AND CONNECTIONS FOR MAIN CIRCUIT.....	14
3.1.1 Names and Functions of Main Circuit Terminals.....	15
3.2 INPUT AND OUTPUT SIGNAL CONNECTION.....	16
3.2.1 Name and function of input signal.....	16
3.2.2 Name and function of output signal.....	17
3.2.3 Input and output connector(CN1)terminal array.....	18
3.2.4 Encoder signal connection.....	19
3.2.5 Communication signal connection.....	19
3.2.6 Encoder cable & power cable connections.....	20
3.2.6.2 EMJ series servo motor.....	20
3.2.6.3 EMG series servo motor.....	20
3.2.6.4 EML series servo motor.....	21
3.2.6.5 EMB series servo motor.....	22
3.3 STANDARD CONNECTION DIAGRAMS.....	23
3.3.1 Three-phase 200V power supply specification.....	23
3.3.2 Three-phase 400V power supply specification.....	24
CHAPTER 4.....	25
OPERATION INTRODUCTION.....	25
4.1 OPERATION INTRODUCTION.....	25
4.1.1 Digital Operator operation introduction.....	25
4.1.2 Basic Mode Selection.....	25
4.1.3 Operation in Status Display Mode.....	26
4.1.4 Operation For position control.....	27
4.1.5 Operation for Parameter Setting Mode.....	28
4.1.6 Operation in Monitor Mode.....	29
4.1.7 Operation in Assistant function mode.....	31

4.1.7.1 Operation in displaying alarm historical data.....	32
4.1.7.2 Operation in recovering default value.....	32
4.1.7.2 Operation in JOG mode.....	33
4.2 Simulative Reference Offset Automatic Adjustment.....	33
4.3 Analog Reference Offset Manual Adjustment.....	35
4.4 Motor Current detection signal offset adjustment.....	37
4.5 Motor current detection offset manual adjustment.....	38
4.6 Checking Servo Software Version.....	38
4.7 Teaching position function.....	39
4.8 static inertia detection.....	39
4.9 Clear absolute encoder multiple-circle information and error.....	40
4.10 Clear absolute encoder relevant error.....	40
CHAPTER 5.....	41
MODBUS COMMUNICATION.....	41
5.1 MODBUS COMMUNICATION FUNCTIONS.....	41
5.1.1 RS-485 communication cable wiring.....	41
5.1.2 MODBUS communication relevant parameters.....	43
5.2 MODBUS COMMUNICATION.....	44
5.2.1 ASCII mode:.....	44
5.2.2 RTU mode:.....	44
5.2.3 Communication protocol structure:.....	46
5.2.4 Communication error disposal.....	51
5.2.5 Servo state data communication address.....	53
CHAPTER 6.....	56
PARAMETER LIST.....	56
6.1 PARAMETER LIST.....	56
6.2 ILLUSTRATION OF PARAMETER FORM.....	63
CHAPTER 7.....	64
PARAMETER EXPLANATION.....	64
7.1 DETAIL EXPLANATION OF PARAMETERS.....	64
APPENDIX.....	84
LIST OF ALARM DISPLAY.....	84

Chapter 1

Checking products and parts names

1.1 Check products

Check the following items after receiving Pronet Series AC servo systems:

Check Items	Reference
Whether the models are the same as what were ordered.	Check the model numbers marked on the nameplates on the servo motor and Servo drive. (Refer to the descriptions of model numbers in the following section.)
Does the servomotor shaft rotate smoothly?	The servomotor shaft is normal if it can be turned smoothly by hand. Servomotors with brakes, however, cannot be turned manually.
Is there any damage?	Check the overall appearance, and check for damage or scratches that may have occurred during transportation.
Is there any screw loose?	Check with the screwdriver.

1.2 Model Designation

1.2.1 Pronet series servo drive

PRONET – 10 A M A
 ESTUN Servo drive **【 1 + 2 】 【 3 】 【 4 】 【 5 】**
 PRONET Series

【 1 + 2 】
rated power

Sign	Specification
08	750W
10	1.0kW
15	1.5kW
20	2.0kW
30	3.0kW
50	5.0kW
75	7.5kW
1A	11kW
1E	15kW

【 3 】 power supply voltage

Sign	Specification
A	200VAC
D	400VAC

【 5 】 design sequence

Sign	Specification
A	Design sequence

【 4 】 control mode

Sign	Specification
M	Speed ,torque & position control
E	Speed,torque & position control (support extended modue)

1.2.2 EMJ series servo motor

EMJ – 08 A D A 1 1
 ESTUN servo motor 【 1 + 2 】 【 3 】 【 4 】 【 5 】 【 6 】 【 7 】
 EMJ series

【 1 + 2 】 Rated power

Code	Specifications
02	200W
04	400W
08	750W
10	1000W

【 3 】 Power voltage

Code	Specifications
A	200VAC

【 4 】 Encoder

Code	Specifications
P	Incremental wire-saving encoder : 2500P/R
D	incremental encoder : 131072P/R
S	Absolute encoder 131072P/R
R	Resoler
【 5 】 Design Sequence	
Code	Specifications
A	Design sequence
B	

【 6 】 Shaft end

Code	Specifications
1	Flat,without keys (standard)
2	Flat, with keys,with screw thread

【 7 】 Options

Code	Specifications
1	None
2	With oil seal
3	With brake(DC24V)
4	With oil seal,With brake(DC24V)

1.2.3 EMG series servo motor

EMG – **10** **A** **D** **A** **1** **1**
 ESTUN servo motor **【 1 + 2 】** **【 3 】** **【 4 】** **【 5 】** **【 6 】** **【 7 】**
 EMG series

【 1 + 2 】 rated power

Sign	Specification
10	1.0kW
15	1.5kW
20	2.0kW
30	3.0kW
50	5.0kW

【 3 】 power voltage

Sign	Specification
A	200VAC

【 4 】 encoder

Sign	Specification
P	Incremental encoder : 2500P/R
D	incremental encoder : 131072P/R
S	Absolute encoder 131072P/R
R	Resoler

【 5 】 Design sequence

Code	Specifications
A	Design sequence

【 6 】 shaft end

Sign	Specification
1	Flat,without keys(standard)
2	Flat,with keys,With screw thread

【 7 】 options

Sign	Specification
1	None
2	With oil seal
3	With brake (DC24V)
4	With oil seal,with brake (DC24V)

1.2.4 EML series servo motor

EML **-** **10** **A** **D** **A** **1** **1**
 ESTUN servo motor **【 1 + 2 】** **【 3 】** **【 4 】** **【 5 】** **【 6 】** **【 7 】**
 EML series

【 1 + 2 】 rated power

code	Specification
10	1.0kW
20	2.0kW
30	3.0kW
40	4.0kW

【 3 】 power supply

code	Specification
A	200VAC

【 4 】 encoder

code	Specification
P	Incremental wire-saving: 2500P/R
D	incremental Encoder : 131072P/R
S	Absolute encoder 131072P/R
R	Resolver
【 5 】 Design Sequence	
A	Design sequence

【 6 】 shaft end

code	Specification
1	Flat, without keys (standard)
2	Flat, with keys, with screw thread

【 7 】 option

code	Specification
1	None
2	With oil seal
3	With brake (DC24V)
4	With oil seal and brake(DC24V)

1.2.5 EMB series servo motor

EMB – 1E D S A 1 1
 ESTUN servo motor 【1 + 2】 【3】 【4】 【5】 【6】 【7】
 EMB series

【1 + 2】 rated power

code	Specification
75	7.5kW
1A	11.0kW
1E	15.0kW

【3】 power supply

code	Specification
D	400VAC

【4】 encoder

code	Specification
P	Incremental wire-saving encoder : 2500P/R
D	incremental encoder : 131072P/R
S	absolute encoder : 131072P/R
R	resolver

【5】 design sequence

code	Specification
A	Design sequence

【6】 shaft end

code	Specification
1	Flat, without keys (standard)
2	Flat, with keys and tap

【7】 options

code	Specification
1	None
2	With oil seal
3	With holding brake (DC24V)
4	With oil seal and holding brake(DC24V)

Chapter 2

Installation

2.1 Servodrive

Pronet Series Servo drive is a base-mounted type servo controller. Incorrect installation will cause problems. Always observe the installation instructions described below.

 Caution
<ul style="list-style-type: none"> • Never use the products in an environment subject to water, corrosive gases, inflammable gases, or combustibles. Failure to observe this caution may result in electric shock or fire. • Do not step on or place a heavy object on the product. Failure to observe this caution may result in injury. • Do not cover the inlet or outlet parts and prevent any foreign objects from entering the product. Failure to observe this caution may cause internal elements to deteriorate resulting in malfunction or fire. • Be sure to install the product in the correct direction. Failure to observe this caution may result in malfunction. • Provide the specified clearances between the SERVO DRIVE and the control panel or with other devices. Failure to observe this caution may result in fire or malfunction. • Do not apply any strong impact. Failure to observe this caution may result in malfunction.

2.2.1 Storage and transportation

When the Servo drive is to be stored with the power cable disconnected, store it in the following temperature range: Between -20°C and 85°C

 Caution
<ul style="list-style-type: none"> • Do not store or install the product in the following places. • Locations subject to direct sunlight. • Locations subject to temperatures outside the range specified in the storage or installation temperature conditions. • Locations subject to humidity outside the range specified in the storage or installation humidity conditions. • Locations subject to condensation as the result of extreme changes in temperature. • Locations subject to corrosive or flammable gases. • Locations subject to dust, salts, or iron dust. • Locations subject to exposure to water, oil, or chemicals. • Locations subject to shock or vibration. Failure to observe this caution may result in fire, electric shock, or damage to the product. • Do not hold the product by the cables or motor shaft while transporting it. Failure to observe this caution may result in injury or malfunction. • Do not place any load exceeding the limit specified on the packing box. Failure to observe this caution may result in injury or malfunction.

2.2.2 Installation sites

Notes of operation installation are described as follows:

Condition	Safety notes
Installation in a Control Panel	Design the control panel size, unit layout, and cooling method so the temperature around the servo drive does not exceed 55 °C (131 °F)
Installation Near a Heating Unit	Minimize the heat radiating from the heating unit as well as any temperature rise caused by natural convection so the temperature around the servo drive does not exceed 55 °C (131 °F).
Installation Near a Source of Vibration	Install a vibration isolator on the servo drive to avoid subjecting it to vibration.
Installation at a Site Exposed to Corrosive Gas	Corrosive gas does not have an immediate effect on the servo drive but will eventually cause the electronic components and contactor-related devices to malfunction. Take appropriate action to avoid corrosive gas.
Other Situations	Do not install the servo drive in hot, humid locations or locations subject to excessive dust or iron powder in the air.

2.2.3 Installation orientation

Install the SERVO DRIVE perpendicular to the wall as shown in the figure. The Servo drive must be oriented this way because it is designed to be cooled by natural convection or a cooling fan.

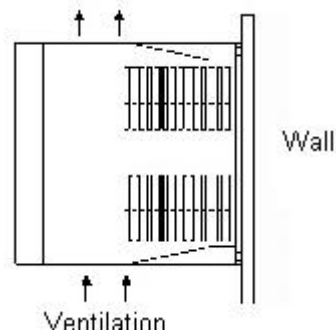

2.2.4 Installation method

When installing multiple Servodrives side by side in a control panel, observe the following installation method:

Servo drive orientation

Install the Servo drive perpendicular to the wall so the front panel containing connectors faces outward.

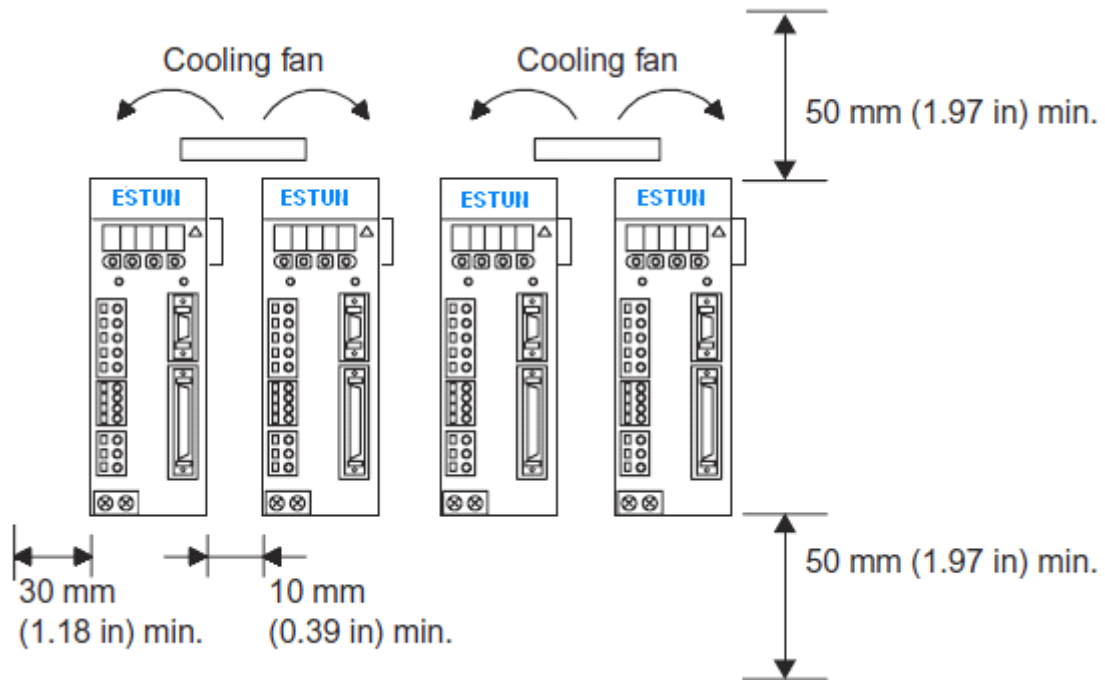

Cooling

As shown in the figure above, allow sufficient space around each Servo drive for cooling by cooling fans or natural convection.

Side-by-side Installation

When installing Servodrives side by side as shown in the figure above, allow at least 10 mm (0.39 in) between and at least 50 mm (1.97 in) above and below each Servo drive. Install cooling fans above the Servo drives to avoid excessive temperature rise and to maintain even temperature inside the control panel.

Environmental Conditions in the Control Panel

1. Ambient Temperature: 0 to 55°C (32 to 131° F)
2. Humidity: 90% RH or less
3. Vibration: 4.9 m/s²
4. Condensation and Freezing: None
5. Ambient Temperature for Long-term Reliability: 45 °C (113 °F) or less

Operation



Caution

- Conduct trial operation on the servomotor alone with the motor shaft disconnected from machine to avoid any unexpected accidents.
Failure to observe this caution may result in injury.
- Before starting operation with a machine connected, change the settings to match the parameters of the machine.
Starting operation without matching the proper settings may cause the machine to run out of control or malfunction.
- Forward run prohibited (P-OT) and reverse run prohibited (N-OT) signals are not effective in JOG mode.
- When using the servomotor for a vertical axis, install the safety devices to prevent workpieces to fall off due to occurrence of alarm or overtravel. Set the servomotor so that it will stop in the zero clamp state at occurrence of overtravel.
Failure to observe this caution may cause workpieces to fall off due to overtravel.
- Do not touch the SERVO DRIVE heatsinks, regenerative resistor, or servomotor while power is ON or soon after the power is turned OFF.
Failure to observe this caution may result in burns due to high temperatures.
- Do not make any extreme adjustments or setting changes of parameters.
Failure to observe this caution may result in injury due to unstable operation.
- When an alarm occurs, remove the cause, reset the alarm after confirming safety, and then resume operation.
Failure to observe this caution may result in injury.
- Do not use the servo brake of the servomotor for ordinary braking.
Failure to observe this caution may result in malfunction.

Chapter 3

Wirings and connections

3.1 Wirings and connections for main circuit

Always observe the following notes when wires or connects the circuit:

Caution

- Do not connect a three-phase power supply to the U, V, or W output terminals. Failure to observe this caution may result in injury or fire.
- Securely connect the power supply terminals and motor output terminals. Failure to observe this caution may result in fire.
- Do not bundle or run power and signal lines together in the same duct. Keep power and signal lines separated by at least 30 cm (11.81 in). Failure to observe this caution may result in malfunction.
- Use twisted-pair shielded wires or multi-core twisted pair shielded wires for signal and encoder (PG) feedback lines. The maximum length is 3 m (118.11 in) for reference input lines and is 20 m (787.40 in) for PG feedback lines.
- Do not touch the power terminals for five minutes after turning power OFF because high voltage may still remain in the SERVO DRIVE. Make sure the charge indicator is turned OFF first before starting an inspection.
- Avoid frequently turning power ON and OFF. Do not turn power ON or OFF more than once per minute. Since the SERVO DRIVE has a capacitor in the power supply, a high charging current flows for 0.2 seconds when power is turned ON. Frequently turning power ON and OFF causes main power devices such as capacitors and fuses to deteriorate, resulting in unexpected problems.
- Observe the following precautions when wiring main circuit terminal blocks.
- Remove the terminal block from the SERVO DRIVE prior to wiring.
- Insert only one wire per terminal on the terminal block.
- Make sure that the core wire is not electrically shorted to adjacent core wires.
- Do not connect the SERVO DRIVE for 200 V directly to a voltage of 400 V. The SERVO DRIVE will be destroyed.
- Always use the specified power supply voltage. An incorrect voltage may result in burning.
- Take appropriate measures to ensure that the input power supply is supplied within the specified voltage fluctuation range. Be particularly careful in places where the power supply is unstable. An incorrect power supply may result in damage to the product.
- Install external breakers or other safety devices against short-circuiting in external wiring. Failure to observe this caution may result in fire.

3.1.1 Names and Functions of Main Circuit Terminals

Terminal Symbol	Name	Power supply	Drive model PRONET	Function
L1, L2, L3	Main circuit power Supply input terminals	200V	□□A	Three phase 200~230VAC+10,-15% (50/60Hz)
		400V	□□D	Three phase 380~440VAC+10,-15% (50/60Hz)
U, V, W	Servo motor connection terminals	—	—	Connect with the servo motor
L1C, L2C	Control circuit, power supply input terminals	200V	□□A	Single phase 200~230VAC+10,-15% (50/60Hz)
		400V	□□D	Single phase 380~440VAC+10,-15% (50/60Hz)
	Grounding terminal	—	—	Connects to the power supply ground terminal and servo motor ground terminal
B1, B2, B3	Outside regenerative resistor connection terminal	200V	□□A	Normal short B2-B3(for the inside regenerative resistor). Remove the wire between B2 and B3 and connect an external regenerative resistor between B1 and B2 if the capacity of inside regenerative resistor is insufficient
B1, B2		400V	□□D	Connect an external regenerative resistor between B1 and B2.
$\oplus 1, \oplus 2$	DC reactor for harmonic suppression terminal	200V	□□A	Normally,short $\oplus 1 - \oplus 2$.If countermeasure against power supply harmonic waves is needed, connect an DC reactor between $\oplus 1 - \oplus 2$
		400V	□□D	—
\ominus	Main circuit minus terminal	—	—	Normal not connected

3.2 Input and output signal connection

3.2.1 Name and function of input signal

Control mode	Signal	Pin no.	Function	
Speed Position Torque	/S-ON	14	Servo ON: motor power on	
	/P-CON	15	Choose the following functions through setting parameter	
			PI/P control switch	If on, switch speed loop control mode from PI to P control
			Rotation direction switch	Use this signal for switching rotation direction when use the function "internal setting speed selection"
			Control mode switch	Switch control mode
			Zero Clamp	[Speed control]if ON, reference speed value is "0"
			Reference pulse prohibit	[Position control] when ON, stop reference pulse input
	P-OT N-OT	16 17	Forward rotation prohibit Reverse rotation prohibit	Over travel prohibit: when ON, stop the servo motor's rotation
	/PCL /NCL	41 42	Choose the following functions through setting parameter	
			Forward rotation current limit Reverse rotation current limit	Current limit function is effective if ON.
			Internal speed selection	Choose different internal setting speed
/ALM-RST	39	Alarm reset: release servo alarm status		
DICOM	13	I/O signal power supply source, should provide 24VDC by the client		
Speed	VREF+	1	Speed reference difference input: $\pm 10V$	
	VREF-	2		
Position	PULS+	30	Pulse input form:	
	PULS-	31	*signal + pulse train	
	SIGN+	32	*CCW+CW pulse	
	SIGN-	33	*two phase pulse (90° phase differential)	
	PPI	34	Collector open-circuit reference power source (Separately preset 2K Ω /0.5W resistor inside of the drive)	
	/CLR	40	Position error pulse clearing: clear position error pulse during position control	
Torque	T-REF+	26	Torque reference difference input: $\pm 10V$	
	T-REF-	27		

3.2.2 Name and function of output signal

Control mode	Signal	Pin no.	Function	
Speed Position Torque	ALM+	5	Servo alarm: Turn OFF when check abnormal status.	
	ALM-	6		
	/TGON+	7	Motor rotation detect: Turn on when motor rotation is over the setting value.	
	/TGON-	8		
	/S-RDY+	9	Servo ready: Turn on if there is no alarm when control circuit and main circuit are powered.	
	/S-RDY-	10		
	PAO+	20	A phase signal	Two-phase (A phase 、 B phase) PG frequency dividing output signal
	PAO-	21		
	PBO+	22	B phase signal	
	PBO-	23		
	PCO+	24	C phase signal	Homing pulse (C phase) signal
PCO-	25			
	FG	Metal shell	If the shield of connector cable CN1 is connected with the metal shell, it is connected with shell ground	
Speed	/V-CMP+	11	Consistent speed: Turn on when the speed of motor is in the same condition with reference speed.	
	/V-CMP-	12		
Position	/COIN+	11	Position complete: When on after position complete(deviation pulse reach to the setting value)	
	/COIN-	12		
Maintain	/CLT	—	Maintain functions could be allocated to /TGON、 /S-RDY、 /V-CMP (/COIN) signal pins by amending parameter setting。 /CLT: Torque limit output. Above setting value ON /BK: Breaker linkage output. Release break when on.	
	/BK			
	—	4, 18, 19, 29, 35, 36, 37, 38, 43, 44, 45, 47, 49	Unused pins	

3.2.3 Input and output connector(CN1)terminal array

Pin no.	Name	Function	Pin no.	Name	Function	
1	VREF+	Speed reference difference input: $\pm 10V$	26	T-REF+	Torque reference difference input: $\pm 10V$	
2	VREF-		27	T-REF-		
3	AGND	Analog ground	28	AGND	Analog ground	
4	—	Not use	29	—	Not use	
5	ALM+	Servo alarm	30	PULS+	Command pulse input	
6	ALM-		31	PULS-		
7	/TGON+	Motor rotation detection	32	SIGN+	Command pulse input	
8	/TGON-		33	SIGN-		
9	/S-RDY+	Servo ready	34	PPI	Collector open-circuit reference power source	
10	/S-RDY-		35	—	Not use	
11	/COIN+	Position complete	36	—	Not use	
12	/COIN-		37	—	Not use	
13	DICOM	I/O signal 24VDC power supply	38	—	Not use	
14	/S-ON	Servo ON	39	/ALM-RST	Alarm release	
15	/P-CON	Position control switch	40	/CLR	Clear position bias pulse	
16	P-OT	Forward drive prohibit	41	/PCL	Forward external torque limit	
17	N-OT	Reverse drive prohibit	42	/NCL	Reverse external torque limit	
18	—	Not use	43	—	Not use	
19	—	Not use	44	—	Not use	
20	PAO+	Encoder A phase signal	Two phase pulse frequency dividing output signal	45	—	Not use
21	PAO-			46	DGND	Digital ground
22	PBO+	Encoder B phase signal	Homing pulse signal	47	—	Not use
23	PBO-			48	DGND	Digital ground
24	PCO+	Encoder C phase signal	Homing pulse signal	49	—	Not use
25	PCO-			50	DGND	Digital ground

Note:

The following input and output can be allocated or change the function by user parameters setting.

Input: /S-ON, /P-CON, P-OT, N-OT, /ALM-RST, /CLR, /PCL, /NCL

Output: /TGON, /S-RDY, /COIN

Related details, please reference to 'parameter detail explanation' Pn509, Pn510 and Pn511

3.2.4 Encoder signal connection

- Encoder connector(CN2) terminal array

Pin no.	Name	Function	Pin no.	Name	Function
1	PA	PG input A phase	11	PU	PG input U phase
2	/PA	PG input/A phase	12	/PU	PG input/U phase
3	PB	PG input B phase	13	PV	PG input V phase
4	/PB	PG input/B phase	14	/PV	PG input/V phase
5	PC	PG input C phase	15	PW	PG input W phase
6	/PC	PG input/C phase	16	/PW	PG input/W phase
7	PS	PG serial signal input	17	BAT+	Battery(+)[absolute encoder]
8	/PS	PG serial signal input	18	BAT-	Battery(-)[absolute encoder]
9	PG5V	PG power source + 5V	19	GND	PG power source 0V
10			20		

3.2.5 Communication signal connection

- Communication connector(CN3) terminal array

Terminal	Name	Function
1	5V	5VDC power supply
2	5V	
3	485+	RS-485 communication terminal
4	DGND	Grounding
5	DGND	
6	485-	RS-485 communication terminal
7	CANH	CAN communication terminal
8	CANL	CAN communication terminal

- Communication connector(CN4) terminal array

Terminal	Name	Function
1	—	Not use
2	—	Not use
3	485+	RS-485 communication terminal
4	DGND	grounding
5	DGND	
6	485-	RS-485 communication terminal
7	CANH	CAN communication terminal
8	CANL	CAN communication terminal

3.2.6 Encoder cable & power cable connections

3.2.6.2 EMJ series servo motor

● Motor connector specification

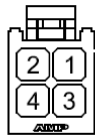

connector: 172167-1 (AMP)
pin: 170360-1 (AMP)

Pin No.	Signal	Color
1	U phase	red
2	V phase	blue
3	W phase	white
4	FG	Greenyellow

● Encoder connector specification

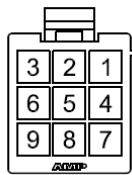

connector(pin): CGRSD-7BFMA-SL8001(CHOGR1)
Incremental/Absolute encoder

Pin No.	Signal	Color
1	S+	blue
2	S-	Blue/black
★3	BAT+	brown
★4	BAT-	Brown/black
5	PG5V	Red
6	PG0V	black
7	FG	shield

resolver

Pin No.	Signal	Color
1	Sin+	blue
2	Sin-	yellow
3	Cos+	red
4	Cos-	black
5	R1	Red/white
6	R2	Yellow/white
7	FG	shield

Notes: Incremental encoder has no BAT+、BAT- signal.

3.2.6.3 EMG series servo motor

● Motor receptacle specification

receptacle: MS3102A20-4P (EMG-10A/15A/20A); MS3102A22-22P (EMG-30A/50A)

connector: MS3108B20-4S (EMG-10A/15A/20A); MS3108B22-22S (EMG-30A/50A)

cable clamp: MS3057-12A

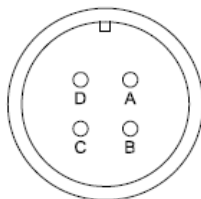

Pin	Signal	Color
A	U phase	red
B	V phase	blue
C	W phase	white
D	FG	Green/yellow

● Encoder receptacle specification

receptacle: MS3102A20-29P
 connector: MS3108B20-29S
 cable clamp: MS3057-12A
 Incremental/absolute encoder

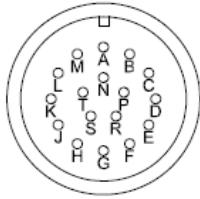

pin	signal	colour
K	S+	Blue
L	S-	Blue/black
★T	BAT+	Brown
★S	BAT-	Brown/black
H	PG5V	red
G	PG0V	black
J	FG	shield

resolver

pin	signal	color
K	Sin+	blue
L	Sin-	yellow
T	Cos+	red
S	Cos-	black
H	R1	Red/white
G	R2	Yellow/white
J	FG	shield

Notes: Incremental encoder has no BAT+, BAT- signal.

3.2.6.4 EML series servo motor

● Motor receptacle specification

receptacle: MS3102A20-4P (EML-10A); MS3102A22-22P (EML-20A/30A/40A)
 connector: MS3108B20-4S (EML-10A); MS3108B22-22S (EML-20A/30A/40A)
 cable clamp: MS3057-12A

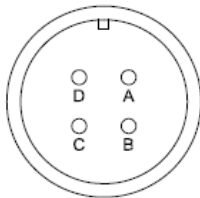

code	signal	color
A	U phase	red
B	V pahse	blue
C	W phase	white
D	FG	Green/black

● Encoder receptacle specification

receptacle: MS3102A20-29P
 connector: MS3108B20-29S
 cable clamp: MS3057-12A
 Incremental absolute encoder

resolver

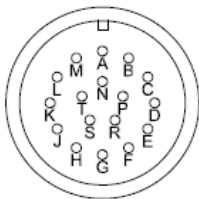

pin	signal	colour
K	S+	Blue
L	S-	Blue/black
★T	BAT+	Brown
★S	BAT-	Brown/black
H	PG5V	red
G	PG0V	black
J	FG	shield

pin	signal	colour
K	Sin+	Blue
L	Sin-	Yellow
★T	COS+	red
★S	COS-	black
H	R1	Red/white
G	R2	Yellow/white
J	FG	shield

3.2.6.5 EMB series servo motor

● Motor receptacle specification

receptical: MS3102A32-17P
 connector: MS3108B32-17S
 cable clamp: MS3057-12A

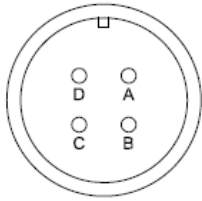

code	signal	color
A	U phase	red
B	V phase	blue
C	W phase	white
D	FG	Green/yellow

● Encoder receptacle specification

Receptacle: MS3102A20-29P
 Connector: MS3108B20-29S
 Cable clamp: MS3057-12A
 absolute encoder

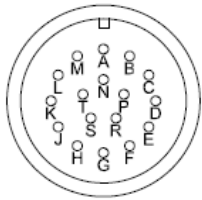

pin	signal	colour
K	S+	Blue
L	S-	Blue/black
T	BAT+	Brown
S	BAT-	Brown/black
H	PG5V	red
G	PG0V	black
J	FG	shield

resolver

pin	signal	colour
K	Sin+	Blue
L	Sin-	Yellwo
T	COS+	red
S	COS-	black
H	R1	Red/white
G	R2	Yellow/white
J	FG	shield

3.3 Standard Connection diagrams

3.3.1 Three-phase 200V power supply specification

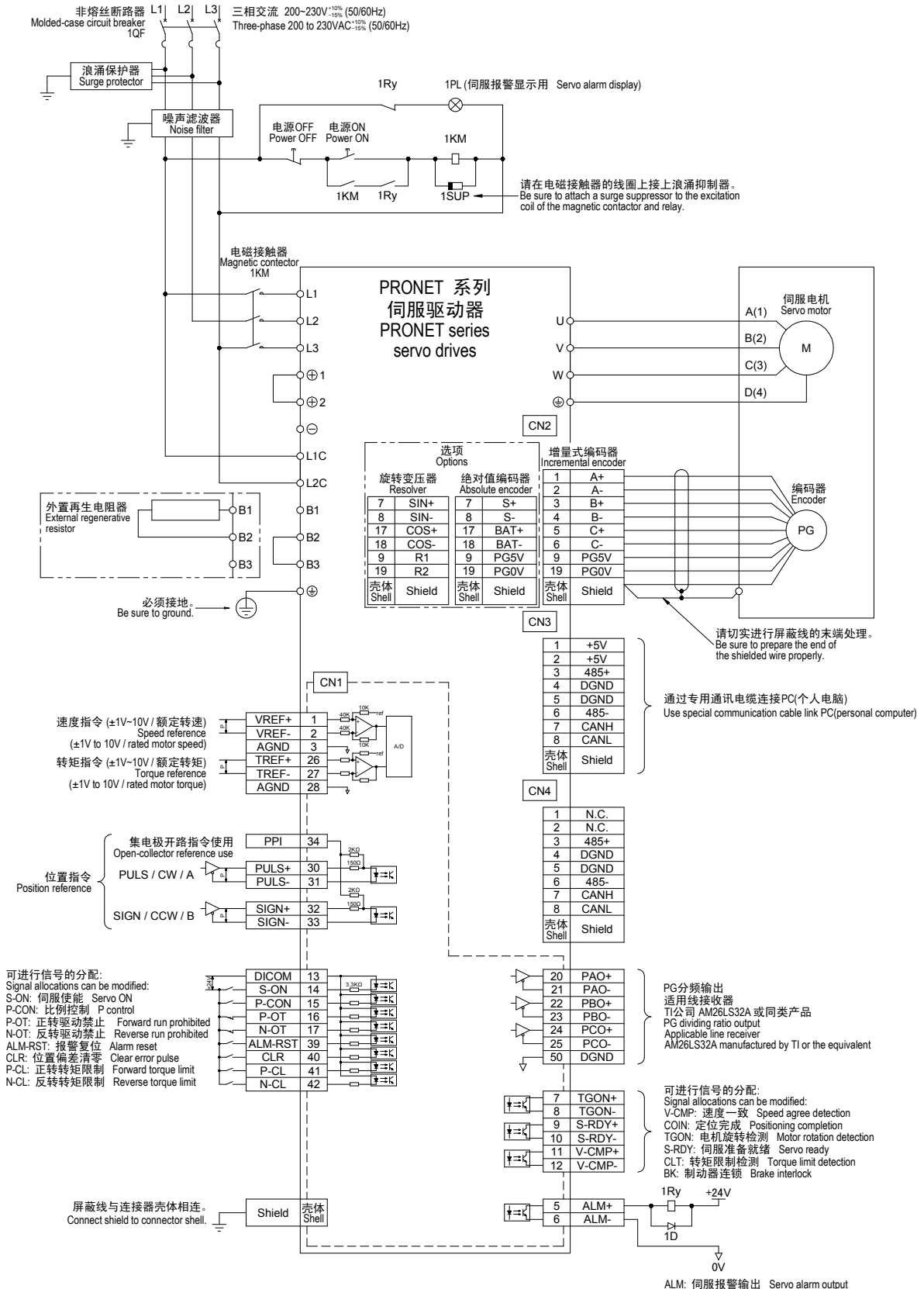

3.3.2 Three-phase 400V power supply specification

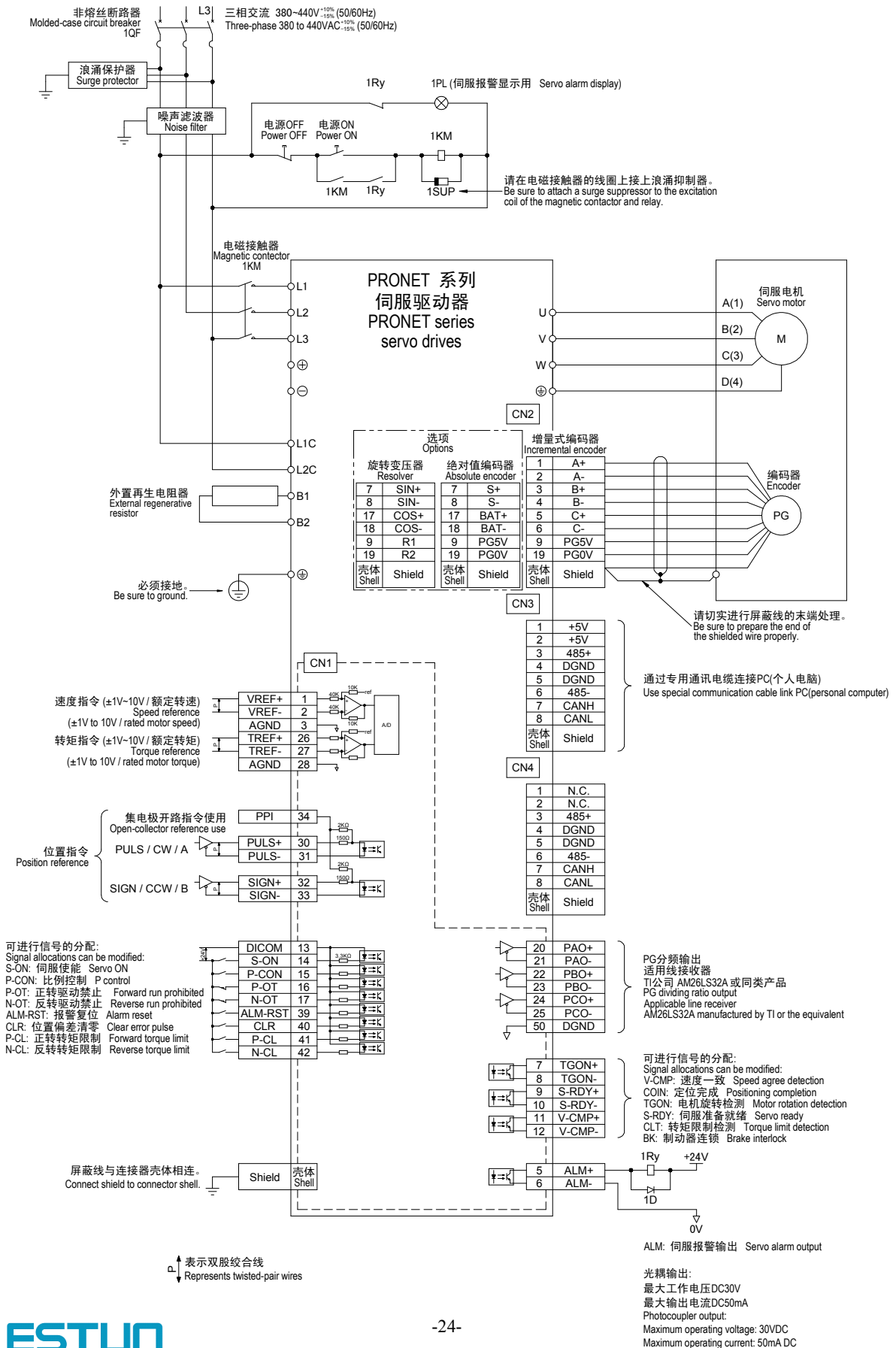

Chapter 4

Operation introduction

4.1 Operation introduction

4.1.1 Digital Operator operation introduction

Name	Function
INC key	Press to display the parameter settings and set values. Press INC key to increase the set value Press DEC key to decrease the set value.
DEC key	
MODE key	Press to select the status display mode, set mode, monitor mode, or error trace back mode. Press to cancel setting when set the parameters.
ENTER key	Press to display the parameter set, set values and release alarm.

4.1.2 Basic Mode Selection

Through switching among basic modes of digital operator, It is able to operate status display, parameter setting, Monitor and operation etc. Digital Operator operation allows status display, parameter setting, operating reference, and auto-tuning operations. Each time the mode key is pressed, the next mode in the sequence is selected.

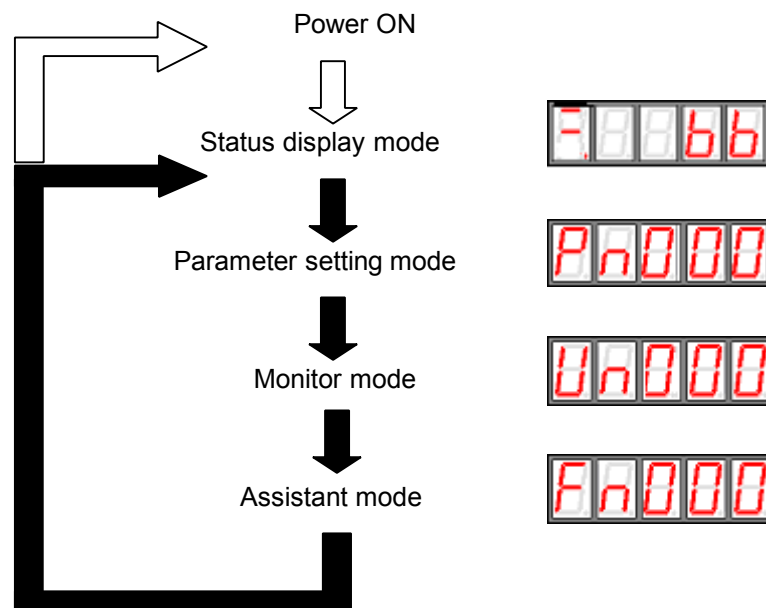

4.1.3 Operation in Status Display Mode

The status display mode displays the Servo drive status as bit data and codes.

■ Selecting Status Display Mode

The status display mode is displayed when the power is turned ON. If the status display mode does not displayed, select the mode by using Mode Key to switch.

■ Keys for the status display are shown below

The display varies in different contents among speed control, torque control and position control.

For Speed and torque Control

Speed coincidence *

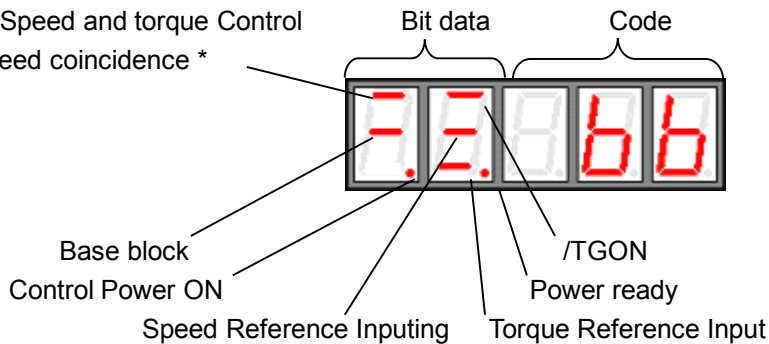

* It is highlighted when in torque control mode.

Bit displays contents

Bit data	Descriptions
Control Power ON	Lit when SERVODRIVE control power ON.
Base block	Lit at base block. Not lit at servo ON.
Speed Coincidence	Lit when the error between motor speed and the reference speed is below preset value Preset value: Pn501(standard value 10min/r)
/TGON	Lit when motor speed exceeds preset value. Not lit if motor speed is below preset value Preset value: set in Pn503 (standard value 20r/min)
Speed Reference Input	Lit if input speed reference exceeds preset value. Not lit if input speed reference is below preset value. Preset value: set in Pn503 (standard value 20r/min)
Torque Reference Input	Lit if input torque reference exceeds preset value. Not lit if input torque reference is below preset value. Preset value: 10% rated torque
Main circuit Power Ready	Lit when main power supply circuit is normal. Not lit when power is OFF

Brief-Code displays

Code	Description
	Base block Servo OFF (motor power OFF)
	Run Servo ON (motor power ON)
	Forward Rotation Prohibited (P-OT) P-OT OFF status
	Reverse Rotation Prohibited (N-OT) N-OT OFF status
	Alarm Status Displays alarm number

Press ENTER to clear present alarm.

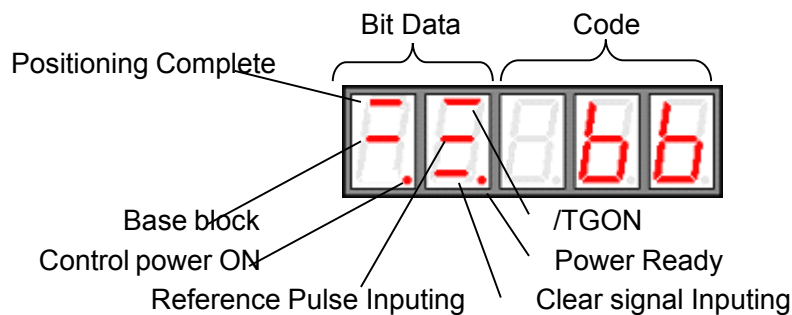

4.1.4 Operation For position control



Bit data display

Bit data	Display
Control power ON	Lit when Servo drive control power ON.
Base block	Lit at base block. Not lit at servo ON.
Position	Lit if error between position reference and actual motor position is below preset value. Preset value: Pn501(standard setting:10 pulse)
/TGON	Lit if motor speed exceeds preset value. Not lit if motor speed is below preset value. Preset value: set in Pn50 (standard setting:20r/min)
Reference pulse input	Lit if reference pulse is input Not lit if no reference pulse is input.
Clear signal Input	Lit when error counter clear signal is input. Not lit when error counter clear signal is not input.
Main circuit Power Ready	Lit when main circuit power is normal. Not lit when main circuit power is OFF

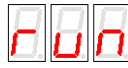
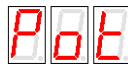
Code display

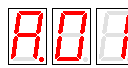
Code	Description
	Base Block Servo OFF. (motor power OFF)
	Run Servo ON (motor power ON)
	Forward Rotation Prohibited 1CN-12 (P-OT) OFF.
	Reverse Rotation Prohibited 1CN-13 (N-OT) OFF
	Alarm Status Display the alarm number

Press ENTER to clear alarm if present status is alarm

4.1.5 Operation for Parameter Setting Mode

Select or adjust the functions through setting parameters. The parameter list is in the appendix.

■Parameter changing procedures

Set the parameter datas when need to adjust the parameters. Modify the confirmed range in Appendix List of Parameters. These are the operation procedures for setting parameters Pn102 from 100 to 85.

1. Press MODE to select parameter setting mode.



2. Press INC key or DEC key to select parameter number.



3. Press ENTER key to display parameter data in step 2.



4. Press INC or DEC to change the data to the desired number 00085. Hold the button to accelerate the change of value. When the data reach the max. or Min., the value will remain unchanged, if press INC/DEC.



5. Press ENTER or MODE to go back to parameter display.



In addition, press MODE and ENTER at the same time to enter into parameter displacement status to modify parameter, then press both MODE and ENTER key to back off. Operate displacement of parameter in step 3 and 4. Press ENTER for longer time to enter into edit condition then press MODE to save and quit, or press ENTER for a longer time to quit then press ENTER to back off parameter displacement edition status, then press ENTER to back to parameter display.

Note: If the left side of digital operator display “b”, it will display parameter in present binary system.

If display “H”, it will display Hexadecimal and this parameter can only be modified in displacement editing condition, or can not be modified.

4.1.6 Operation in Monitor Mode

The monitor mode allows the reference values to input into the Servo Drive, I/O signal status, and Servo drive internal status to be monitored.

The monitor mode can be set during motor operation.

■ Using the Monitor Mode

The example operation procedure below show how to display 150, the contents of monitor number Un-001.

1. Press MODE to select monitor mode.



2. Press INC key or DEC key to select the monitor number to display.



3. Press ENTER to display the selected monitor data at step 2.



4. Press ENTER again to back to monitor number display.



Above is the operation procedure for displaying 1500 in monitor number Un001

■ Monitor Mode Displays

Below is the monitor mode displays:

Monitor No.	contents	
Un000	Actual motor speed r/min	
Un001	Input speed reference value r/min	
Un002	Input torque reference percentage% (with relative rated torque)	
Un003	Internal torque reference value%(with relative rated torque)	internal status bit display
Un004	Encoder rotating angle pulse numbers	
Un005	Input signal monitor	
Un006	Encoder signal monitor	
Un007	output signal monitor	
Un008	Pulse given frequency (Unit: 1KHz)	
Un009	Pulse count of motor rotated	
Un010	Pulse rate of motor rotated (x10 ⁴)	
Un011	Error pulse counter lower 16 digit	
Un012	Error pulse counter higher 16 digit	
Un013	Received pulse counter lower digit	
Un014	Received pulse counter high digit (x10 ⁴)	
Un015	Load inertia percentage	
Un016	Motor overload ratio	

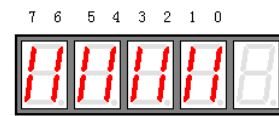

Bit data display

Monitor No.	Bit No.	Display
Un005	0	1CN_14 input
	1	1CN_15 input
	2	1CN_16 input
	3	1CN_17 input
	4	1CN_39 input
	5	1CN_40 input
	6	1CN_41 input
	7	1CN_42 input

Monitor No.	Bit No.	Display
Un006	0	W phase
	1	V phase
	2	U phase
	3	C phase
	4	B phase
	5	A phase
	6	(Not used)
	7	(Not used)

Monitor No.	Bit No.	Content
Un007	0	1CN_05, 1CN_06
	1	1CN_07, 1CN_08
	2	1CN_09, 1CN_10
	3	1CN_11, 1CN_12

4.1.7 Operation in Assistant function mode

Use panel manipulator to do some application operation when in assistant function mode, The detailed functions are shown as below:

Function No.	Content
Fn000	Display historical alarm data
Fn001	recover factory default
Fn002	JOG mode
Fn003	speed reference offset autoregulation
Fn004	speed reference hand regulation
Fn005	Motor current inspection offset autoregulation
Fn006	Motor current inspection offset hand regulation
Fn007	Servo software version display
Fn008	Position Teaching function
Fn009	Static inertia inspection
Fn010	Clear absolute value loop information and error
Fn011	Clear absolute value encoder relative error

4.1.7.1 Operation in displaying alarm historical data

The latest ten times alarms could be displayed in alarm historical data
The following shows the procedure to display the historical data.

1. Press MODE to select assistant function mode

2. Press INC or DEC to select function number of alarm historical record.



3. Press ENTER to display the latest alarm code.

Alarm serial number Alarm code

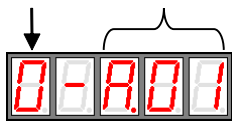

4. Press INC or DEC to display other recent occurred alarm code.

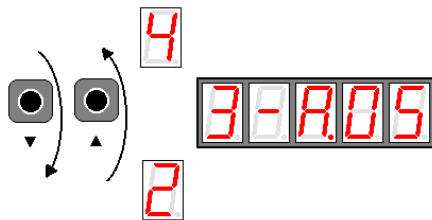

5. Press ENTER to return to function number display.



If the user wants to clear all the historical record, just hold ENTER for one second with displaying alarm code, then all the historical data will be deleted.



4.1.7.2 Operation in recovering default value

The follows are procedures for recovering default value.

1. Press MODE to select assistant mode.

2. Press INC or DEC to select function number of recovering parameter default value



3. Press ENTER to enter parameter default recovery mode.



4. Hold ENTER key for one second to recover parameter to default value.

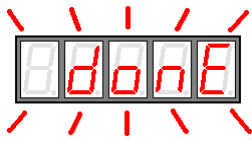

5. Release ENTER key to return to function number display.



4.1.7.2 Operation in JOG mode

The following are the operation procedures in JOG mode

1. Press MODE to select assistant function mode.
2. Press INC or DEC to select Function number of JOG mode.



3. Press ENTER to enter JOG mode.



4. Press MODE to enter Servo ON (motor ON) status.



5. Press MODE to switch between servo ON and Servo OFF. If motor running is required, servo must be ON.

Motor runs when press INC or DEC.

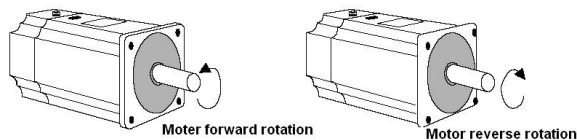

6. Press ENTER to return to function number display. Servo is OFF. (Motor is not under position.)



4.2 Simulative Reference Offset Automatic Adjustment

The motor may rotate slowly when the reference voltage is intended to be 0 V. This happens when the host controller or external circuit has a small offset (measured in mV) in the reference voltage.

The reference offset automatic adjustment mode automatically measures the offset and adjusts the reference voltage. It adjusts both speed and torque references.

The following diagram illustrates automatic adjustment of an offset in the reference voltage from the host controller or external circuit.

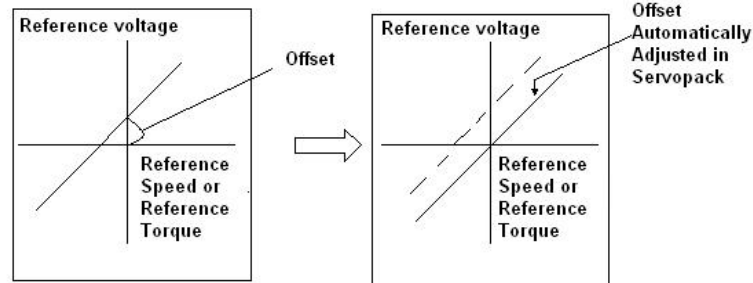

After completion of offset automatic adjustment, the amount of offset is stored in the Servodrive. The amount of offset can be checked in the speed reference offset manual adjustment mode. Please Refer to Simulative Reference Offset Manual Adjustment Mode for details

The reference offset automatic adjustment mode cannot be used where a position loop is formed with the host controller and the error pulses recorded in servo are set to zero. In this case, use the speed reference offset manual adjustment mode. Please Refer to Reference Offset Manual Adjustment Mode for details.

When the input speed reference is zero, Zero-clamp speed control is able to force the motor to stop. Please Refer to Using Zero-Clamp for details.

Note

Please automatically adjust analog reference offset on the servo OFF status.

The following are the operation procedures for analog reference offset automatic adjustment.

Input the (intended) 0 V reference voltage from the host controller or external circuit.

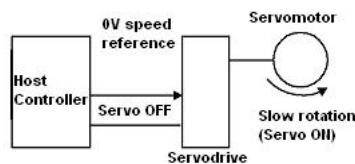

1. Press Mode to select assistant function mode.
2. Press INC or DEC key to select function number of speed reference offset.



3. Press ENTER to enter speed reference offset automatic adjustment.

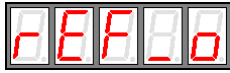

4. Press MODE. Speed offset will be automatically adjusted after displaying twinkling for one minute.



5. Press ENTER to return to function number display



6. This is the end of reference offset automatic adjustment.

4.3 Analog Reference Offset Manual Adjustment

Analog reference offset manual adjustment is the function of speed/torque control(analog reference) mode. Please use it under the following conditions:

- If position loop is formed with the host controller and adjust the offset pulse ZERO when servo lock is stopped.
- To deliberately set the offset to some value.

It is available when checking the data of offset automatic adjustment.

The basic function is the same as analog reference offset automatic adjustment. But must directly input offset while adjusting. Offset can be set as speed reference or torque reference.

Offset Adjustment Range and Setting Units are as follows:

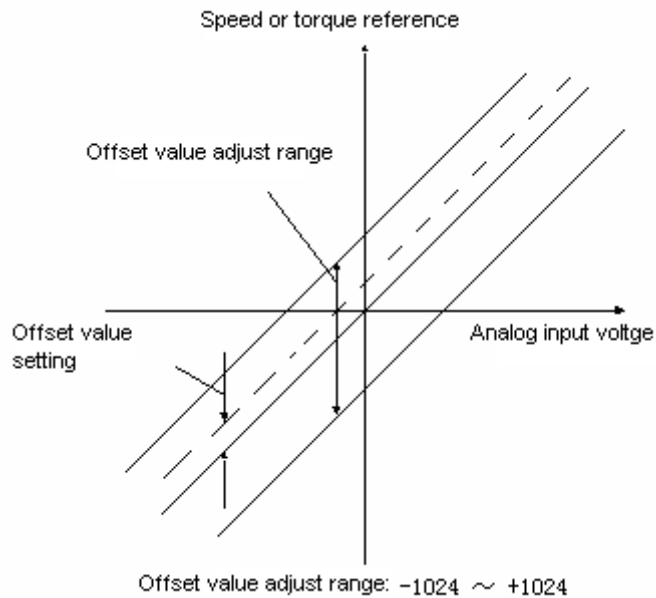
**Note:**

When automatic adjustment offset is over manual adjustment range (-1024~+1024), manual adjustment is not effective.

The following is operation procedures of analog reference offset manual adjustment.

1. Press MODE to select assistant function mode.
2. Press INC or DEC to select speed reference offset manual adjustment function number

Fn004

3. Press ENTER to enter speed reference offset manual adjustment mode.

- . . SPD

4. Set servo ON signal (/S-ON) ON, it displays as follows

. . . SPD

5. Press ENTER for a second to display speed reference offset

0000

6. Press INC or DEC to adjust the offset.
 7. Press ENTER for a second to display step 4.
- Press ENTER to go back to function number display.

Fn004

This is the end of speed reference offset automatic adjustment.

4.4 Motor Current detection signal offset adjustment

Current detection offset is adjusted at Estun before shipping. Basically, the customer need not perform this adjustment. Perform this adjustment only if highly accurate adjustment is required when the Digital Operator is combined with a specific motor.

This section illustrates the offset automatic adjustment and manual adjustment operation

Note:

Motor current detection offset adjustment could only be performed when the Servo is OFF. Deteriorated situations might occur when start this function involuntary; especially start the manual adjustment involuntary.

Please perform the offset automatic adjustment when torque pulse is obviously too high compared with other servodrivers.

Motor current detection offset automatic adjustment

Follow the procedure below to perform current detection offset automatic adjustment

1. Press MODE to select assistant function mode.
2. Press INC or DEC to select function number of motor current detection offset automatic adjustment

A digital display showing the text 'Fn005' in red characters on a black background.

3. Press ENTER to enter motor current detection offset automatic adjustment mode.

A digital display showing the text 'E0r80' in red characters on a black background.

4. Press MODE and offset will be adjusted after flashing for a second.

A digital display showing the text 'done' in red characters on a black background. The display is surrounded by red dashed lines, indicating it is flashing.

A digital display showing the text 'E0r80' in red characters on a black background. An arrow points from the 'done' display above to this one.

5. Press ENTER to return function number display.

A digital display showing the text 'Fn005' in red characters on a black background.

This is the end of motor current detection offset automatic adjustment

4.5 Motor current detection offset manual adjustment

Follow the procedure below to perform motor current detection offset manual adjustment

1.Press MODE to select assistant function mode.

2.Press INC or DEC to select function number of motor current detection offset manual adjustment.



3.Press ENTER to enter into motor current detection offset manual adjustment.



4.Press MODE to switch U phase (Cu1_o) and V phase (Cu2_o) current detection offset adjustment mode.



5.Hold ENTER for a second to display present phase current detection data.



6.Press INC or DEC to adjust offset.



7.Hold ENTER for a second to return to the display of step 3 or step 4.

8.Press ENTER again to return to function number display.



This is the end of motor current detection offset manual adjustment

Note:

Motor current detection offset manual adjustment range:-1024~+1024。

4.6 Checking Servo Software Version

The follow bellow is the operation procedures of servo software version.

1. Press MODE to select assistant function mode.
2. Press INC or DEC to select the function number of servo software version.

The LED display shows 'Fn007' in red characters on a black background.

3. Press ENTER to display DSP software version number(D or E or F is displayed at the highest position)

The LED display shows 'd-1.00' in red characters on a black background.

4. Press MODE to display FPGA/CPLD software version number(P is displayed at the highest position)

The LED display shows 'P-1.00' in red characters on a black background.

5. Press MODE again to switch back to display the DSP software version number
6. Press ENTER to return to display the function number

4.7 Teaching position function

Following operation procedure is for teaching position.

1. Press MODE to select assistant function mode.
2. Press INC or DEC to select the function number of servo software version.

The LED display shows 'Fn008' in red characters on a black background.

3. Press ENTER to display as follows

The LED display shows 'LEACH' in red characters on a black background.

4. Press ENTER for long to display as follows

The LED display shows 'EEEnd' in red characters on a black background.

5. Teaching has been completed and release ENTER

4.8 static inertia detection

1. Press MODE key, choose assistant function mode
2. Press INC or DEC, choose servo software edition display function number

3. Press ENTER to display as follows:

4. Press MODE key to start rotate. Here, it displays motor dynamic speed.

5. When motor stops, it displays the total inertia of motor and load. The unit is $\text{kg}\cdot\text{cm}^2$

The inertia detection is complete.

Note: Please assure that motor has more than 6 circles of displacement in the CCW direction.

4.9 Clear absolute encoder multiple-circle information and error

1. Press MODE, choose assistant function mode

2. Press INC or DEC, choose clear absolute encoder multiple-circle information and error function number.

3. Press ENTER to display as follows:

4. Press MODE to proceed clear operation.

5. Operation complete

Note: This operation will clear the absolute position of the encoder. Please assure mechanical and personnel safety beforehand. Besides, it will clear other encoder error at the same time.

4.10 Clear absolute encoder relevant error

1. Press MODE, choose assistant function mode

2. Press INC or DEC, choose clear absolute encoder relevant error function number

3. Press ENTER to display as follows:

4. Press MODE to proceed clear operation

5. Operation complete

Chapter 5

Modbus communication

5.1 MODBUS Communication Functions

5.1.1 RS-485 communication cable wiring

PRONET drivers have MODBUS communication function with RS-485 interface, which can modify parameters and monitor servo drive status and so on. Definitions of servo drive communication connector terminal are as follows:

CN3 terminal definition:

Interface No.	Name	Function
1	5V	Power supply:5VDC
2	5V	
3	485+	RS-485 communication terminal
4	DGND	ground
5	DGND	
6	485-	RS-485 communication terminal
7	CANH	CAN communication terminal
8	CANL	CAN communication terminal

CN4 terminal definition:

Interface No.	Name	Function
1	—	maintain
2	—	maintain
3	485+	RS-485 communication terminal
4	DGND	ground
5	DGND	
6	485-	RS-485 communication terminal
7	CANH	CAN communication terminal
8	CANL	CAN communication terminal

Instructions:

(1) The cable length can reach 100 meters when in a less disturbed environment. However, if transmission speed is above 9600bps, please use less than 15 meters communication cable to ensure the accuracy of transmission.

(2) It's available for up to 31 PCS servo drives to work together when RS485 is applied. 485 network end-point need to connect a 120Ω resistor separately. If need to connect more appliances. If you want to connect with more appliance, a RS485 repeater must be needed to expand connection units.

(3) CN3 of servo drive is always taken as input terminals, and CN4 is always taken as communication cable output terminals (If still need to connect slave station, connect cable from this terminal to the next slave station facility; if needn't, add balance resistor in this terminal). If several pronet servo drives connected, it is prohibited to directly connect CN3 of any two servo drivers.

For example, RS-485 network is composed of a piece of PLC, A, B, C three sets of Pronets. Cable wiring is as follows:

PLC → CN3 of drive A, CN4 of drive A → CN3 of drive B, CN4 of drive B → CN3 of drive C, CN4 of drive C → 120Ω terminal resistor.

5.1.2 MODBUS communication relevant parameters

Pa. No.	discription	need repower on	Effective under control mode	Function and meaning
Pn700	Hex	Yes	ALL	Pn700.0 MODBUS communication baud rate [0] 4800bps [1] 9600bps [2] 19200bps Pn700.1 communication protocol selection [0] 7, N, 2 (Modbus,ASCII) [1] 7, E, 1 (Modbus,ASCII) [2] 7, O, 1 (Modbus,ASCII) [3] 8, N, 2 (Modbus,ASCII) [4] 8, E, 1 (Modbus,ASCII) [5] 8, O, 1 (Modbus,ASCII) [6] 8, N, 2 (Modbus,RTU) [7] 8, E, 1 (Modbus,RTU) [8] 8, O, 1 (Modbus,RTU) Pn700.2 communication protocol selection [0] no protocol SCI communicate [1] MODBUS SCI communicate Pn700.3 maintain
Pn701	Modbus Axis address	Yes	ALL	Aix address of MODBUS protocol communication

5.2 MODBUS communication

Only when Pn213 is set as 1 or 2 can communicate with MODBUS protocol. There are two modes for MODBUS communication: ASCII (American Standard Code for information interchange) mode or RTU (Remote Terminal Unit) mode.

The brief introductions of the two communication modes are as follows:

Code Meaning

5.2.1 ASCII mode:

Every 8-bit datum is consisted by two ASCII characters. For instance: One 1-byte datum 64 H (Hex expression) is expressed as ASCII code '64'. It contains '6' as ASCII code (36 H) and '4' as ASCII code (34 H).

ASCII code for Number 0 to 9, character A to F are as follows:

Number	'0'	'1'	'2'	'3'	'4'	'5'	'6'	'7'
Relevant ASCII code	30H	31H	32H	33H	34H	35H	36H	37H
Character	'8'	'9'	'A'	'B'	'C'	'D'	'E'	'F'
Relevant ASCII code	38H	39H	41H	42H	43H	44H	45H	46H

5.2.2 RTU mode:

Every 8-bit datum is consisted by two 4-bit hex datums. That is to say, a normal hex number. For instance: algorism 100 can be expressed as 64H by 1-byte RTU datum

Datum structure: 10bit character form (apply in 7-bit datum)

11bit character form (apply in 8-bit datum)

5.2.3 Communication protocol structure:

Communication protocol data format:

ASCII mode:

STX	Start character: ' => (3AH)
ADR	Communication address => 1-byte contains 2 pcs of ASCII code
CMD	Reference code => 1-byte contains 2 pcs of ASCII code
DATA(n-1)	Data content => n-word=2n-byte contains 4 pcs of ASCII code, n≤12
.....	
DATA(0)	
LRC	Checking code => 1-byte contains 2 pcs of ASCII code
End 1	End code 1 => (0DH) (CR)
End 0	End code 0 => (0AH) (LF)

RTU mode:

STX	At least stop transmission for 10ms
ADR	Communication address => 1-byte
CMD	Reference code => 1-byte
DATA(n-1)	Data content => n-word=2n-byte, n≤12
.....	
DATA(0)	
CRC	CRC Verifying code => 1-byte
End 1	At least stop transmission for 10ms

Communication protocol data format instructions are as follows:

STX (communication start)

ASCII mode: ':' character

RTU mode: stop time for more than 4 bytes communication time (automatically changed according to different communication speed)

ADR (communication address)

Valid communication addresses range from 1 to 254.

For example: communicate with the servo drive which address is 32 (hex as 20):

ASCII mode: ADR='2', '0'=>'2'=32H, '0'=30H

RTU mode: ADR=20H

CMD (order instruction) and DATA (datum)

Datum structure is formed by order code. Regular order code as follows:

Order code: 03H, read N words(word), N is not more than 20.

For instance: read 2 words from address 0200 H which start from servo addressed at 01 H

ASCII mode:

Order information:

STX	','
ADR	'0'
	'1'
CMD	'0'
	'3'
data start address	'0'
	'2'
	'0'
	'0'
data number (count as Word)	'0'
	'0'
	'0'
	'2'
LRC Verifying	'F'
	'8'
End 1	(0DH)(CR)
End 0	(0AH)(LF)

response information:

STX	','
ADR	'0'
	'1'
CMD	'0'
	'3'
Data number (count as byte)	'0'
	'4'
Data start address Content of 0200H	'0'
	'0'
	'B'
	'1'
Second data start address Content of 0201H	'1'
	'F'
	'4'
	'0'
LRC Verifying	'E'
	'8'
End 1	(0DH)(CR)
End 0	(0AH)(LF)

RTU mode:

Order information:

ADR	01H
CMD	03H
Data start address	02H(high bits)
	00H(low bits)
Data number Count as Word	00H
	02H
CRC verifying	C5H(low bits)
CRC verifying	B3H(high bits)

Response information:

ADR	01H
CMD	03H
data number count as word	04H
data start address, content of 0200H	00H(high bits)
	B1H(low bits)
second data adress, content of 0201H	1FH(high bits)
	40H(low bits)
CRC verifying	A3H(low bits)
CRC verifying	D3H(high bits)

Order code: 06H, write in one character (word)

For instance: write 100 (0064 H) into 01H servo address 0200 H of servo 01H.

ASCII mode:

Order information:

STX	‘.’
ADR	‘0’
	‘1’
CMD	‘0’
	‘6’
datum start address	‘0’
	‘2’
	‘0’
	‘0’
datum content	‘0’
	‘0’
	‘6’
	‘4’
LRC verifying	‘9’
	‘3’
End 1	(0DH)(CR)
End 0	(0AH)(LF)

Response information:

STX	‘.’
ADR	‘0’
	‘1’
CMD	‘0’
	‘6’
datum address	‘0’
	‘2’
	‘0’
	‘0’
datum address, content of 0200H	‘0’
	‘0’
	‘6’
	‘4’
LRC verifying	‘9’
	‘3’
End 1	(0DH)(CR)
End 0	(0AH)(LF)

RTU mode:

Order information:

ADR	01H
CMD	06H
datum start address	02H(high bits)
	00H(low bits)
datum content	00H(high bits)
	64H(low bits)
CRC verifying	89H(low bits)
CRC verifying	99H(high bits)

Response information:

ADR	01H
CMD	06H
datum start address	02H(high bits)
	00H(low bits)
datum content	00H(high bits)
	64H(low bits)
CRC verifying	89H(low bits)
CRC verifying	99H(high bits)

LRC (ASCII mode) and CRC (RTU mode) error detection value calculation:

LRC calculation in ASCII mode

ASCII mode uses LRC (Longitudinal Redunancy Check) error detection value. The exceeded part (e.g. the total value is 128H of hex, then take 28H only) is taken off by the unit of 256 in the total value from ADR to the last information, then calculate and compensate, the final result is LRC error detection value.

Add from ADR data to the last data.

$$01H+03H+02H+01H+00H01H=08H$$

The compensate value is F8H when 2 is selected from 08H, so LRC is “F”, “8”.

CRC calculation of RUT mode:

RTU mode uses CRC (Cyclical Redundancy Check) error detection value.

The process of CRC checksum calculation is as following:

The first step: Load in a 16-bit register of FFFFH, named "CRC" register.

The second step: Run XOR calculation between the first bit (bit 0) of instruction information and

STX	';
ADR	'0'
	'1'
CMD	'0'
	'3'
Start data address	'0'
	'2'
	'0'
	'1'
Data number (Count as number)	'0'
	'0'
	'0'
	'1'
LRC verifying	'F'
	'8'
End 1	(0DH)(CR)
End 0	(0AH)(LF)

16-bit CRC register's Low bit (LSB), save back the result to CRC register.

The third step: Check the lowest bit (LSB) of CRC register, if it is 0, CRC register right move a bit; if it is 1, CRC register right move a bit, then run XOR calculation with A001H;

The fourth step: turn back to the third step, know that the third step has been operated for 8 times, then go to the fifth step.

The fifth step: repeat the second step to the fourth step to the next bit of instruction information, know all the bits had been operated the same way, then comment of CRC register is CRC error detection value.

Illustration: after calculating out the CRC error detection value, in instruction information, the CRC low bit should be filled first, and then fill the high bit of CRC, please refer to the following example:

Read 2 charaters (word) from the 0101H address of 01H servo. The final CRC register comment calculated from ADR to the last bit of information is 3794H, then the instruction information is as following, please note that 94H is transmitted before 37H.

ADR	01H
CMD	03H
Start data address	01H(high bits)
	01H(low bits)
Data number ,count as word	00H(high bits)
	02H(low bits)
CRC Verifying	94H(low bits)
CRC Verifying	37H(high bits)

End1、End0 (Communication check is done)

ASCII mode:

(0DH) as character '\r' [carriage return] and (0AH) as character '\n' [new line] , meaning the end of communication.

RTU mode:

The stop period of 4 bytes communication time exceeding present communication speed rate means communication finished.

Example:

The following C language causes CRC value, the function needs two parameters.

```
unsigned char * data;
```

```
unsigned char length;
```

The function will return unsigned integer mode CRC value.

```
unsigned int crc_chk(unsigned char * data,unsigned char length){
    int i,j;
    unsigned int crc_reg=0xFFFF;
    While (length- -) {
        Crc_reg ^=*data++;
        For (j=0;j<8;j++){
            If (crc_reg & 0x01) {
                crc_reg= (crc_reg >>1) ^ 0xA001;
            } else {
                crc_reg=crc_reg >>1;
            }
        }
    }
    return crc_reg;
}
```

5.2.4 Communication error disposal

It may cause fault while communication, the common fault is as follows:

- Parameter datum address are wrong when read/write parameter.
- The datum exceeds the maximum value of this parameter or less than the minimum value of this parameter while write parameter.
- Datum transmission fault or verifying code fault when communication is disturbed.

When above mentioned communication faults occur, servo drive running won't be affected. Meanwhile, servo drive will feed back an error frame.

The error frame form is as follows:

Host controller datum frame:

Start	Slave station Address	Command	Datum address, data and so on	Verifying
		Command		

Servo drive feedback fault frame:

Start	Slave station address	Response code	error code	Verifying
		Command + 80H		

Error frame responses code=command+80H

Fault code=00H: communication normal

=01H: Servo drive can not identify the required functions

=02H: The required datum address does not exist in the servo drive;

=03H: The required datum in servo is not allowed. (Beyond maximum or minimum value of the parameter)

=04H: Servo drive starts to perform the requirement, but cannot achieve it.

For instance: servo drive axis number is 03H, write into datum 06H corresponding parameter Pn002. Because of the parameter Pn002 range of 0~1, the written data are not allowed. Servo driver will feedback an error frame, the error code is 03H (Exceed parameters' max. value or min. value). The following is the structure:

Host controller datum frame

Start	Slave station address	Instruction	Datum address, data and so on	Verifying
	03H	06H	0002H 0006H	

Servo driver feedback error frame

Start	Slave station address	Response code	Fault code	Verifying
	03H	86H	03H	

Besides, if the datum frame sent from host controller slave station address is 00H, it represents this datum is broadcasted datum, servo drives will not feedback any frames.

5.2.5 Servo state data communication address

Communication data address	Meaning	Description	Operation
Hex			
0000 ~ 02FD	Parameter area	Corresponding parameters in parameter list	Read-write
07F1 ~07FA	Alarm information memory area	Ten former alarms	Read only
07FB	Speed instruction zero offset		Read only
07FC	Torque instruction zero offset		Read only
07FD	Lu zero offset		Read only
07FE	Lv zero offset		Read only
0806 ~ 0814	Monitor data (corresponding with displayed data)		Read only
0806	Speed feedback	Unit:r/min	Read only
0807	Input speed instruction value	r/min	Read only
0808	Input torque instruction percentage	Corresponding rated torque	Read only
0809	Internal torque instruction percentage	Corresponding rated torque	Read only
080A	Encoder rotation pulse number		Read only
080B	Input signal state		Read only
080C	Encoder signal state		Read only
080D	Output signal state		Read only
080E	Pulse setting		Read only
080F	Present location low bits	Unit:1 instruction pulse	Read only
0810	present location high bits	Unit:10000 instruction pulse	Read only
0811	error pulse counter low 16 bits		Read only
0812	error pulse counter high 16 bits		Read only
0813	setting pulse counter low bits	Unit:1 instruction pulse	Read only
0814	Setting pulse counter high bits	Unit:10000 instruction pulse	Read only
0815	Load/inertia percentage	%	Read only
0816	Motor overload percentage	%	Read only
0817	Current alarm		Read only

0900	ModBus communication IO signal	Power off without save	Read -write
0901	Driver state		Read only
0902	Relevant phase value		Read only
0903	Inertia inspection value		Read only
0904	Driver running time	Unit: minute	Read only
090E	Software DSP edition	Edition is displayed by digit	Read only
090F	Software PLD edition	Edition is displayed by digit	Read only
1010	17-bit encoder multi-round message	Unit:one round	Read only,only 17-bit encoder,multi-round 16 bit,single-round 17 bit.
1011	17-bit encoder single round message low bit	Unit:one pulse	
1012	17-bit encoder single round message high bit		
1021	Clear former alarms	01: Clear	Read -write
1022	Clear current alarms	01: Clear	Read -write
1023	JOG servo enable	01: Enable 00: No enable	Read -write
1024	JOG forward rotate	01: Forward rotate 00: Stop	Read-write
1025	JOG backward rotate	01: Backward rotate 00: Stop	Read - write
1026	JOG forward rotate at node position(start signal has been set)	01: Forward rotate 00: Stop	
1027	JOG backward rotate at node position(start signal has been set)	01: Backward rotate 00: Stop	
1028	Pause at node position	01: Pause 00: Cancel pause	
1040	Clear encoder alarm	01: clear	
1041	Clear encoder multi-round data	01: clear	Write only ,only 17-bit encoder

Instruction:

1、 parameter area (communication address 0000 ~ 00DEH)

Corresponding parameters in the parameter list, for instance: parameter Pn000 is relevant to communication address 0000 H; parameter Pn101 is relevant to communication address 0065 H; read-write operation to address 0000 H is the read-write operation to Pn000. If the communication input datum is not within the parameter range, the datum will be abnegated and servo drive will return an operation unsuccessful signal.

2、 Alarm information storage area (07F1 ~ 07FAH)

Historical alarm number	Instruction	Communication address
0	Historical alarm 1 (the latest alarm)	07F1H
1 ~ 8	Historical alarm 1~historical alarm 9	07F2H ~ 07F9H
9	Historical alarm 10 (the longest time)	07F3H

3、 monitor data area (0806 H~ 0814H)

This monitor data corresponding sevo drive panel displays Un000~Un014.

For instance: the corresponding data of communication read address 0807 H (speed setting) is FB16 H. Therefore, the speed setting is-1258r/m.

4、 ModBus communication IO signal

Use communication control digit IO signal. This datum won't be reserved after power off.

5、 drive state (0901 H)

This 1-word represents system current state. Meaning of each bit is as follows:

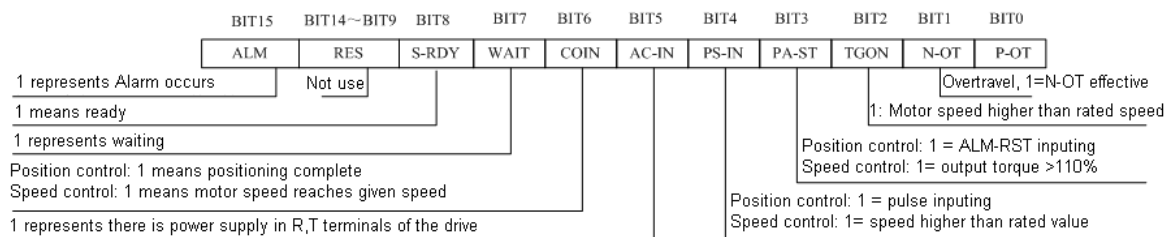

6、 software edition (090EH)

Use digit to represent drive's software edition. E.g. If the read datum is D201H , it means the software edition is D-2.01.

Chapter 6

Parameter List

6.1 PARAMETER LIST

Parameter	Description	Unit	Range	Default value	Re-power on needed
Pn000	Binary Pn000.0: parameter servo ON Pn000.1: Forward rotation input signal (P-OT) is prohibited. Pn000.2: Forward rotation input signal (N-OT) is prohibited. Pn000.3: instant power off output servo alarm (ALM)	—	0~1111	0	Needed
Pn001	Binary Pn001.0: CCW,CW selection Pn001.1: analog speed limited enable Pn001.2: analog torque limited enable Pn001.3:the second electronic gear enable	—	0~1111	0	Needed
Pn002	Binary Pn002.0: electronic gear switch mode Pn002.1: reserved Pn002.2: absolute encoder used as incremental encoder Pn002.3: reserved	—	0~0111	0010	Needed
Pn003	Binary Pn003.0: code wheel fault code alarm enable Pn003.1: C pulse protection Pn003.2: low speed compensation Pn003.3: overload increase	—	0~1111	0	Needed
Pn004	Hex Pn004.0: Stop mode Pn004.1: offset counter clear mode Pn004.2: instruction pulse form Pn004.3: reverse pulse	—	0~0x34 25	0	Needed

Parameter	Description	Unit	Range	Default value	Re-power on needed
	Hex Pn005.0:torque forward feedback mode Pn005.1: Control mode [0] Speed control(analog instruction) [1] Position control (pulse train instruction) [2] Torque control(analog instruction) [3] speed control(node instruction) Speed control (zero instruction) [4] Speed control(node instruction)↔speed control (analog instruction) [5] Speed control(node instruction)↔Positioning control(pulse train instruction) [6] Speed control(node instruction)↔Torque control(analog instruction) [7] Positioning control(pulse train instruction)↔Speed control(analog instruction) [8] Positioning control(pulse train instruction)↔Torque control(analog instruction) [9] Torque control(analog instruction)↔Speed control(analog instruction) [A] Speed control(analog instruction)↔zero clamping control [B] positioning control(pulse train instruction)↔Positioning control(pulse prohibited) [C]Positioning control(parameter instruction) [D]Speed control (parameter instruction) [E]Pressure control (parameter instruction) Pn005.2:Out-of-tolerance alarm enable Pn005.3: Motor type	—	0~0x33 D3	0	Need
Pn006	Hex Pn006.0: Bus mode Pn006.1:Resolver resolution selection Pn006.2: Reserved	—	0~0x00 32	0x0020	Need

Parameter	Description	Unit	Range	Default value	Re-power on needed
	Pn006.3: Reserved				
Pn100	Real time auto tune setting 0: User manual gain 1,2,3= Regular mode;4,5,6= Upright load 1,4 = No change of load inertia;2,5 =Small change of load inertia;3,6= Big change of load inertia	—	0~6	1	Need
Pn101	Load rigid selection	—	0~15	5	No need
Pn102	Speed loop gain	Hz	1~2500	160	No need
Pn103	Speed loop integration time	0.1m s	1~4096	200	No need
Pn104	Position loop gain	1/s	0~1000	40	No need
Pn105	Torque instruction filter constant	0.1m s	0~250	4	No need
Pn106	Load inertia percentage	—	0~2000 0	0	No need
Pn107	The second speed loop gain	Hz	1~2500	40	No need
Pn108	The second speed loop integration time constant	0.1m s	1~4096	200	No need
Pn109	The second position loop gain	Hz	0~1000	40	No need
Pn110	The second torque instruction filter constant	0.1m s	0~250	150	No need
Pn111	Speed offset	r/min	0~300	0	No need
Pn112	Forward feedback	%	0~100	0	No need
Pn113	Forward feedback filter	0.1m s	0~640	0	No need
Pn114	Torque forward feedback	%	0~100	0	No need
Pn115	Torque forward feedback filter	0.1m s	0~640	0	No need
Pn116	P/PI switch condition 0: Torque instruction percentage 1: Offset counter value 2: Setting acceleration value 3: Setting speed value 4: PI Fixed PI	—	0~4	0	Need
Pn117	Torque switch threshold	%	0~300	200	No need
Pn118	Offset counter switch threshold	Instru ction pulse	0~1000 0	0	No need
Pn119	Setting acceleration switch threshold	10rp	0~3000	0	No need

Parameter	Description	Unit	Range	Default value	Re-power on needed
		m/s			
Pn120	Setting speed switch threshold	rpm	0~1000 0	0	No need
Pn121	Gain switch condition 0: fixed to the first group gain 1: Outside switch gain switched 2: Torque percentage 3: Offset counter value 4: Setting acceleration value (10r/min) 5: Setting speed value 6: positional instruction input	—	0~6	0	Need
Pn122	switch delayed time	0.1m s	0~2000 0	0	No need
Pn123	Switch threshold level		0~2000 0	0	No need
Pn124	Reserved				
Pn125	Position gain switch time	0.1m s	0~2000 0	0	No need
Pn126	Switch hysteresis		0~2000 0	0	No need
Pn127	low speed test filtering	0.1m s	0~100	10	No need
Pn128	speed gain increase relationship in real time adjustment	—	0~3	3	No need
Pn129	Low speed verifying coefficient	—	0~3000 0	0	No need
Pn130	Friction load	0.1%	0~3000	0	No need
Pn131	Friction compensation speed hysteric zone	rpm	0~100	0	No need
Pn132	Viscous friction load	0.1%/ 1000r pm	0~1000	0	No need
Pn133	Reserved	—	1~2000	40	No need
Pn134	Reserved	0.1m s	1~2000 0	200	No need
Pn135	Reserved	—	0~3000 0	0	No need
Pn136	Reserved	—	0~100	0	No need
Pn137	Reserved	0.1m s	0~1000	10	No need
Pn138	Reserved	0.1m	0~1000	10	No need

Parameter	Description	Unit	Range	Default value	Re-power on needed
		s			
Pn200	PG frequency	Pulse	16~16384	16384	Need
Pn201	The first electronic gear molecule	—	1~65535	1	Need
Pn202	Electronic gear denominator	—	1~65535	1	Need
Pn203	The second electronic gear molecule	—	1~65535	1	Need
Pn204	Position instruction filtering time constant	0.1ms	0~32767	0	No need
Pn205	Position instruction filtering form selection	—	0~1	0	Need
Pn300	speed instruction input gain	rpm/v	0~3000	150	No need
Pn301	Inside speed 1	rpm	0~6000	100	No need
Pn302	Inside speed 2	rpm	0~6000	200	No need
Pn303	Inside speed 3	rpm	0~6000	300	No need
Pn304	Parameter speed	rpm	0~6000	500	No need
Pn305	JOG speed	rpm	0~6000	500	No need
Pn306	Soft reset accelerating time	ms	0~10000	0	No need
Pn307	Soft reset decelerating time	ms	0~10000	0	No need
Pn308	Speed filtering time constant	ms	0~10000	0	No need
Pn309	S curve rising time	ms	0~10000	0	No need
Pn310	Speed instruction curve form 0: Incline 1: S curve 2: Once filtering 3: Twice filtering	—	0~3	0	Need
Pn311	S form selection	—	0~3	0	No need
Pn312	DP communication inching speed	rpm	- 6000~6000	500	No need
Pn313	Reserved	0.1ms	0~10000	0	No need
Pn314	Reserved	0.1bar/v	0~10000	400	No need

Parameter	Description	Unit	Range	Default value	Re-power on needed
Pn315	Reserved	0.1bar/v	0~1000 0	400	No need
Pn400	Torque instruction gain	0.1V/ 100%	10~100	33	No need
Pn401	Forward direction torque inside limit	%	0~300	300	No need
Pn402	Reversed direction torque inside limit	%	0~300	300	No need
Pn403	Forward direction outside torque limit	%	0~300	100	No need
Pn404	Reversed outside torque limit	%	0~300	100	No need
Pn405	Plug braking torque limit	%	0~300	300	No need
Pn406	Speed limit in torque control period	rpm	0~6000	1500	No need
Pn407	Wave trap 1 frequency	Hz	50~500 0	5000	No need
Pn408	Wave trap 1 depth	—	0~11	1	No need
Pn408	Wave trap 2 frequency	Hz	50~500 0	5000	No need
Pn410	Wave trap 2 depth	—	0~11	1	No need
Pn500	Position error	Puls	0~5000	10	No need
Pn501	speed error	rpm	0~100	10	No need
Pn502	Zero clamping rotating speed	rpm	0~3000	10	No need
Pn503	Rotation inspection speed TGON	rpm	0~3000	20	No need
Pn504	Offset counter overflow alarm	256Puls	1~3276 7	1024	No need
Pn505	Servo on waiting time	ms	0~2000	200	No need
Pn506	Basal waiting process	10ms	0~500	0	No need
Pn507	Braking waiting speed	rpm	10~100	100	No need
Pn508	Braking waiting time	10ms	10~100	50	No need
Pn509	Match input interface to the interface of signal hex 4 bit	—	0~0xBB BB	0x3210	Need
Pn510	Match input interface to the interface of signal hex 4 bit	—	0~0xBB BB	0x7654	Need
Pn511	Output signal distribute	—	0~0x04 44	0x0210	Need
Pn512	Bus control input node low bit enable		0~1111	0	No need
Pn513	Bus control input node high bit enable		0~1111	0	No need
Pn514	Input end filtering	0.2ms	0~1000	1	No need
Pn515	Reserved	0.2ms	0~3	1	No need
Pn516	Select the contrary of input end signal	—	0~1111	0	No need

Parameter	Description	Unit	Range	Default value	Re-power on needed
Pn517	Select the contrary of input end signal	—	0~1111	0	No need
Pn518	Reserved	ms	50~2000	125	No need
Pn519	Reserved	0.1ms	0~10000	3	No need
Pn520	Reserved	0.1ms	0~60000	50	No need
Pn600	Point position control position pulse	10000P	-9999~9999	0	No need
Pn601	Point position control position pulse	1P	-9999~9999	0	No need
				
Pn631	Point position control position pulse	1P	-9999~9999	0	No need
Pn632	Point position speed control	rpm	0~6000	500	No need
				
Pn647	Point position speed control	rpm	0~6000	500	No need
Pn648	Point position once filtering	0.1ms	0~32767	0	No need
				
Pn663	Point position once filtering	0.1ms	0~32767	0	No need
Pn664	Stop time	50ms	0~300	10	No need
				
Pn679	Stop time	50ms	0~300	10	No need
Pn680	Reserved				
Pn681	Hex Pn681.0:One time/recycle, reset/reference point selection Pn681.1: Change step and reset mode Pn681.2: Change step input signal mode Pn681.3: Reserved	—	0~x0333	0x0000	No need
Pn682	Program mode	—	0~1	0	No need

Parameter	Description	Unit	Range	Default value	Re-power on needed
Pn683	Program start step	—	0~15	0	No need
Pn684	Program stop step	—	0~15	1	No need
Pn685	Search travel speed	rpm	0~3000	1500	No need
Pn686	Leave travel switch speed	rpm	0~3000	30	No need
Pn687	Teaching position pulse	1000 0P	- 9999~9 999	0	No need
Pn688	Teaching position pulse	1P	- 9999~9 999	0	No need
Pn700	Hex Pn700.0:MODBUS communication baud rate Pn700.1:MODBUS communication protocols Pn700.2:Communication protocols selection Pn700.3: Reserved	—	0~0x01 82	0x0151	Need
Pn701	MODBUS shaft address	—	1~247	1	Need

6.2 Illustration of parameter form

Form	code	Brief description
Function selection switch	Pn000~Pn006	Control mode, stop mode and some function selections
Servo gain parameter and so on	Pn100~Pn129	Position gain, speed gain, rigidity and so on
Position control relationship parameter	Pn200~Pn205	PG frequency division, electronic gear and so on
Speed control relationship parameter	Pn300~Pn312	Speed instruction input, soft reset and so on.
Torque control relationship parameter	Pn400~Pn406	Torque limit and so on
Parameter to control input and output ends	Pn500~Pn520	Distribution of input/output end' functions
Relevant parameter of point position control	Pn600~Pn686	Relevant parameter of internal point position control.
Communication parameter	Pn700~Pn704	Communication relevant parameter set

Chapter 7

Parameter Explanation

7.1 Detail explanation of parameters

Pa. No.	Name	Need Repower on	effective control mode	Function and meaning
Pn000	Binary	Need	ALL	<p>Pn000.0: parameter servo ON [0] Outside S-ON valid [1] Outside S-ON invalid, motor excitation signal turned on automatically after S-RDY output</p> <p>Pn000.1 Forward direction input prohibited [0] Outside P-OT valid, it moves according to the Pn004.0 setting time sequence when it reaches the travel limit. [1] Outside P-PT invalid.</p> <p>Pn000.2 Reversed direction input prohibited [0] Outside N-OT valid, it moves according to the Pn004.0 setting time sequence when it reach the travel limit. [1]。 Outside P-PT invalid.</p> <p>Pn000.3 Momentary power off alarm output [0] No alarm in one momentary power off circle [1] Alarm in one momentary power off circle.</p>
Pn001	Binary	Need	Pn001.0 ALL Pn001.1 T Pn001.2 P, S Pn001.3 P	<p>Pn001.0 CCW,CW selection [0] CCW: counter clockwise is the forward direction [1] CW: clockwise is the forward direction</p> <p>Pn001.1 analog speed limit enable [0] Inter parameter Pn406 is the limited speed value while torque control period [1] Vref input analog voltage corresponding value is the speed limited value while torque control. All control modes of this parameter are effective</p> <p>Pn001.2 analog torque limit enable [0] Pn401~Pn404 acts as torque limit [1] Tref input corresponding value acts as torque limit</p> <p>Pn001.3 The second electric gear enable [0] No the second electric gear PCON signal actin</p>

Pa. No.	Name	Need Repower on	effective control mode	Function and meaning
				g as P/PI switch [1] The second electric gear effective PCON signal can only act when Pn005.3=1
Pn002	Binary	Need	ALL	<p>Pn002.0 electric gear switch mode [0] Corresponding time sequence, for electronic gear 1</p> <p>[1] Corresponding time sequence, for electronic gear 2</p> <p>Set the time sequence 0 and 1 both available</p> <p>fault time sequence</p> <p>Pn002.1 Reserved Pn002.2 serial absolute encoder alarms relevant enable [0] alarm valid</p>

Pa. No.	Name	Need Repower on	effective control mode	Function and meaning
				[1] alarm invalid Pn002.3:Reserved
Pn003	Binary	Need	ALL	<p>Pn003.0 Code panel error code alarm enable [0] A.30~A.33:Alarm invalid [1] A.30~A.33:Alarm valid</p> <p>Pn003.1 C pulse protection [0] No C pulse protection [1] with C pulse protection</p> <p>Pn003.2 Low speed compensation [0] No low speed verifying [1] With low speed verifying to prevent motor crawling, but sometimes the intensity of motor low speed verifying has to be determined by value of Pn129</p> <p>Pn003.3 overload enhancement [0] No overload enhancement function [1] With overload enhancement function, In some frequent start-stop applications, this function can enhance the overload capacity when surpass 2 times' rated overload in instantaneous time.</p>
Pn004	Hex	Need	Pn004.0 ALL Pn004.1 P Pn004.2 P Pn004.3 P	<p>Pn004.0 Stop mode [0] Cancel braking after DB braking and running stop. [1] Stop freely [2] DB when servo OFF, plug braking stop when over travel,servo OFF [3] Stop freely when servo OFF, plug braking stop when over travel,servo OFF [4] DB when servo OFF, zero clamp after plug braking stop when over travel [5] Freely stop when servo OFF, zero clamp after plug braking stop when over travel</p> <p>Pn004.1 Offset counter clear mode [0] Offset counter clear when S-OFF, does not clear when over travel [1] Offset counter does not clear [2] Offset counter clear when S-OFF or over travel (except zero clamp)</p> <p>Pn004.2 Instruction pulse mode [0] Symbol + pulse [1] CW+CCW</p>

Pa. No.	Name	Need Repower on	effective control mode	Function and meaning
				[2] A+B (orthogonal 1 frequency doubling) [3] A+B (orthogonal 2 frequency doubling) [4] A+B (orthogonal 4 frequency doubling) Pn004.3 Pulse negation [0] PULS instruction no negation, SIGN instruction no negation [1] PULS instruction no negation, SIGN instruction negation [2] PULS instruction negation, SIGN instruction no negation. [3] PULS instruction negation, SIGN instruction negation
Pn005	Hex	Need	Pn005.0 P, S Pn005.1 ALL Pn005.2 P	Pn005.0 Torque feedforward mode [0] Outside analog (Tref) feedforward invalid, using regular torque feedforward. [1] Outside analog (Tref) feedforward valid, using high speed torque feed forward [2] Outside analog (Tref) feedforward invalid, using high speed torque feedforward [3] Outside analog (Tref) feedforward valid, using regular torque feedforward Pn005.1 Control mode [0] Speed control (analog instruction) PCON: OFF, PI control; ON, P control [1] Position control(pulse train instruction) PCON: OFF, PI control; ON, P control [2] Torque control (analog instruction) PCON malfunction [3] Speed control(node instruction)←→Speed control(zero instruction) PCON: OFF, motor forward rotate; ON, motor backward rotate PCL, NCL: OFF motor stop [4] Speed control(node instruction)←→Speed control (analog instruction) PCON: OFF Motor forward rotate, ON motor backward rotate PCL, NCL: OFF switch to speed control(analog instruction) [5] Speed control (node instruction)←→Position c

Pa. No.	Name	Need Repower on	effective control mode	Function and meaning
				<p>control (pulse train instruction) PCON : OFF motor forward rotate , ON Motor backward rotate PCL, NCL: OFF switch to position control (pulse train instruction) [6] Speed control (node instruction)←→Torque control (analog instruction) PCON : OFF motor forward rotate , ON motor backward rotate PCL, NCL: OFF switch to torque control(analog instruction) [7] Position control (pulse train instruction)←→Speed control (analog instruction) PCON : OFF ; position control (pulse train instruction) ON speed control (analog instruction) [8] position control (pulse train instruction)←→Torque control (analog instruction) PCON : OFF ; position control (pulse train instruction) ON Torque control (analog instruction) [9] Torque control (analog instruction)←→Speed control (analog instruction) PCON: OFF; Torque control(analog instruction) ON Speed control (analog instruction) [A])Speed control(analog instruction)←→zero clamp control PCON: OFF; speed control(analog instruction) ON zero clamp control [B] position control(pulse train instruction)←→position control (pulse prohibited) PCON : OFF position control (pulse train instruction); ON Position control(pulse prohibited) [C] Position control(node instruction) PCON: can be as changing step PCL, NCL: can be as searching reference point or start. [D] Speed control(parameter instruction) PCON, PCL, NCL invalid</p>

Pa. No.	Name	Need Repower on	effective control mode	Function and meaning
				Pn005.2 Overproof alarm enable [0] Overproof alarm no enable [1] overproof alarm enable, alarm when offset counter value surpass the corresponding value of Pn504 [2] Reserved [3] Reserved Pn005.3 Selection of motor type [0] EMJ [1] EMG [2] EML [3] EMB
Pn006	Hex	Need		Pn006.0 Bus mode [0] No bus [1] PROFIBUS-DP V0/V1 [2] PROFIBUS-DP V2 Pn006.1 resolver resolution selection [0] 10 bits [1] 12 bits [2] 14 bits [3] 16 bits Pn006.2 Reserved Pn006.3 Reserved
Pn100	Real time auto adjustment set	Need	P, S	[0] User manual gain [1,2,3] Regular mode [4,5,6] Upright load [1,4] No change of load inertia [2,5] Small change of load inertia [3,6] Big change of load inertia Attention: The auto-adjustment is invalid when the highest speed is below 100rpm in the movement of servo motor, it should be set to user manual gain The auto-adjustment is invalid when the acceleration and deceleration lower than 5000rpm/s, it should be set to user manual gain When leak of machine is too big to be suitable for auto-adjustment during movement course, it should be set to user manual gain When the differences of various speed load are too much to be suitable for auto-adjustment during

Pa. No.	Name	Need Repower on	effective control mode	Function and meaning
				movement course, it should be set to manual gain
Pn101	Load rigid selection	No need	P, S	This value determines the response speed of servo system, normally the rigid should be set larger, but if it is too large, it would suffer the Mechanical impaction. It should be set smaller when vibration is big. The value is valid only when auto-adjustment time
Pn102	Speed loop gain	No need	P, S	This value determines speed loop gain value and load inertia percentage. The corresponding unit is HZ when Pn 106 is set correctly
Pn103	Speed loop integral time	No need	P, S	Decreasing the value can shorten position time, the speed response unit is 0.1ms
Pn104	position loop gain	No need	P	This value determines the position loop gain, increasing this value can improve the rigid of position control servo.It will cause vibration when the value is too much.Unit is 1/s
Pn105	Torque instruction filter constant	No need	P, S, T	Setting torque filtering can remove or decrease the mechanical vibration, but sometimes unreasonable setting will cause mechanical vibration.Unit is 0.1m/s
Pn106	Load inertia percentage	No need	P, S	The percentage between load inertia and motor rotor inertia. The unit is %. Setting value=(load inertia/rotor inertia)x100
Pn107	The second speed loop gain	No need	P, S	These parameters' meaning is same with Pn102~Pn105. These parameters are only need to set when two level gain switch mode is open.
Pn108	The second speed loop integral time constant	No need	P, S	
Pn109	The second loop gain	No need	P	

Pa. No.	Name	Need Repower on	effective control mode	Function and meaning
Pn110	The second torque instruction filter constant	No need	P, S, T	
Pn111	Speed offset	No need	P	The value is to shorten the position time, But if it is set too big or not corresponded well with Pn111, vibration occurs, The relationship between the value and speed instruction, offset counter is as following.
Pn112	Feed forward	No need	P	It is used to set position feed forward value, more higher position lead to faster response and less position offset. It would cause vibration and overswing when it is set too big.Unit:%
Pn113	Feed forward filtering	No need	P	The mechanical impaction caused by smooth position feed forward. It would enlarge feed forward lag and cause vibration if it is set too big. Unit:0.1ms
Pn114	Torque feed forward	No need	P, S	it is used to set torque feed forward value in order to accelerate the speed response. Pls set load rotation inertia percentage correctly while in manual adjustment mode

Pa. No.	Name	Need Repower on	effective control mode	Function and meaning
Pn115	Torque feed forward filtering	No need	P, S	Mechanical impaction caused by smooth torque feed forward . Unit:0.1ms
Pn116	P/PI switch conditions	Need	P, S	0: torque instruction percentage 1: offset counter value 2: setting acceleration value 3: setting speed value 4: fixed PI
Pn117	Torque switch threshold	No need	P, S	The torque threshold value unit from PI control to P control:%
Pn118	Offset counter switch threshold	No need	P	The offset counter threshold value unit from PI control to P :Pulse
Pn119	Setting acceleration switch threshold	No need	P, S	The acceleration threshold value unit from PI control to P :10rpm/s
Pn120	Setting speed switch threshold	No need	P, S	The speed threshold value unit from PI control to P:rpm
Pn121	Gain switch condition	No need	P, S	0: Fixed to the first group gain 1: Outside power switch gain transfer(G-SEL) 2: Torque percentage 3: Offset counter value 4: Setting acceleration value(10r/min) 5: Setting speed value 6: there are position instructions input
Pn122	switch delay time	No need	P, S	How long should the gain switch be delayed when it get to the switch condition.
Pn123	Switch threshold level	No need	P, S	Gain switch's trigger level
Pn124	Reserved			
Pn125	Position gain switch time	No need	P	It can bridge smoothly by the parameter if the change between the two groups' gain is too large.
Pn126	Hysteric s	No need	P, S	It is used to set gain switch movement delay

Pa. No.	Name	Need Repower on	effective control mode	Function and meaning
	witch			
Pn127	speed inspection filtering at low speed	No need	P, S	It sets the filtering during speed inspection at low speed, if it is too large, the speed inspection at low speed will delay.
Pn128	Real time adjustment speed gain increase relationship	No need	P, S	It is the increase times of speed loop gain at the same rigid in the real time auto adjustment. The real time auto adjustment speed loop gain is larger as the value is set larger.
Pn129	Low speed verifying constant	No need	P, S	The anti outside friction, anti crawl strength at low speed. But it will cause vibration if it is set too large.
Pn130	Friction load	No need	P, S	Friction load or fixed load compensation
Pn131	Friction compensation speed period	No need	P, S	Friction start compensation threshold
Pn132	Viscous friction load	No need	P, S	Viscous damping which is direct proportional to speed
Pn133	Reserved	No need	-----	
Pn134	Reserved	No need	-----	
Pn135	Reserved	No need	-----	
Pn136	Reserved	No need	-----	
Pn137	Reserved	No need	-----	
Pn138	Reserved	No need	-----	
Pn200	PG frequency division	Need	P, S, T	Analog encoder output orthogonal differential pulse, the value means the encoder output orthogonal pulses No. When motor rotate a round analog encoder output.
Pn201	The first electrical gear numerator	Need	P	Using electrical gear can match the instruction pulse along with the amount of motor movement corresponding to the motor, it makes the upper device do not need to care mechanical deceleration ratio and encoder pulse No., essentially, it is a setting of frequency doubling or frequency division to instruction pulse.
Pn202	Electrical gear denominator	Need	P	

Pa. No.	Name	Need Repower on	effective control mode	Function and meaning		
Pn203	The second electrical gear numerator	Need	P			
Pn204	Position instruction filtering time constant	No need	P	The smooth effect is better if the smoothness of input pulse is bigger. Delay will occur when it is too big.		
Pn205	Selection of position instruction filtering mode	Need	P	[0]: Once filtering [1]: Twice filtering		
Pn300	Speed instruction input gain	No need	S	The corresponding speed to Each voltage's analog		
Pn301	Inside speed 1	No need	S	Inside speed, the parameter is valid as the control mode is 3~6		
Pn302	Inside speed 2	No need	S	Name of interface	State of interface	Actual Inside speed value Zero speed or switch to other control modes
				PCL	OFF	
Pn303	Inside speed 3	No need	S	NCL	OFF	Inside speed 1
				PCL	ON	
Pn303	Inside speed 3	No need	S	NCL	ON	Inside speed 3
				PCL	OFF	
Pn303	Inside speed 3	No need	S	PCL	ON	Inside speed 2
				NCL	ON	
PCON : OFF forward rotation , ON backward rotation						
Pn304	Parameter speed	No need	S	The parameter can be set to positive value and negative value. When control mode is set to D, it determines the speed of motor		
Pn305	JOG speed	No need	S	The speed of JOG running, direction is decided by the keys		
Pn306	Soft reset	No need	S	The time to 1000rpm acceleration of trapezoid		

Pa. No.	Name	Need Repower on	effective control mode	Function and meaning
	acceleration time			acceleration, Unit: ms
Pn307	Soft reset deceleration time	No need	S	The time to 1000rpm deceleration of trapezoid acceleration, Unit: ms
Pn308	Speed filtering time constant	No need	S	Once filtering time constant unit: ms
Pn309	S curve rising time	No need	S	The time from one speed spot to another by S curve transferring
Pn310	Speed instruction curve mode	Need	S	0: Incline 1: S curve 2: Once filtering 3: Twice filtering
Pn311	Selection of S shape	Need	S	This value determines the transfer mode of S curve
Pn312	Communication inching speed	No need	P, S, T	Bus inching's communication speed's value can be set to positive and negative.
Pn313	Reserved	No need	-----	Can set the bus inching communication speed positive or negative
Pn314	Reserved	No need	-----	
Pn315	Reserved	No need	-----	
Pn400	Torque instruction gain	No need	T	It means the needed analog input voltage's unit is 0.1v/100% in order to get to the rated torque
Pn401	forward rotation torque inside limit	No need	P, S, T	Motor output torque limit value
Pn402	Backward torque inside limit	No need	P, S, T	Motor output torque limit value
Pn403	Forward rotation outside torque limit	No need	P, S, T	Motor output torque limit value
Pn404	Backward	No need	P, S, T	Motor output torque limit value

Pa. No.	Name	Need Repower on	effective control mode	Function and meaning	
	outside torque limit				
Pn405	Plug braking torque limit	No need	P, S, T	Motor output torque limit value	
Pn406	Torque control speed limit	No need	T	Torque control speed limit value	
Pn407	Wave trap 1 frequency	No need	P, S, T	Wave trap 1 frequency	<p>1、Setting wave trap might enlarge the mechanical vibration and response delay under certain work condition</p> <p>2、The wave trap is invalid when the frequency of wave trap is set to 5000</p>
Pn408	Wave trap 1 depth	No need	P, S, T	Wave trap 1 depth	
Pn409	Wave trap 2 frequency	No need	P, S, T	Wave trap 2 frequency	
Pn410	Wave trap 2 depth	No need	P, S, T	Wave trap 2 depth	
Pn500	Position error	No need	P	COIN signal is output if the offset counter value is less than it	
Pn501	Same speed error	No need	P	The same speed signal VCMP is output if the error between speed instruction value and speed feedback value is less than the set value of the parameter.	
Pn502	Zero clamping rotating speed	No need	S	The motor is locked by the temporary position loop mode when the speed corresponding to input analog is less than the set value of the parameter.	
Pn503	Rotation inspection speed TGON	No need	P, S, T	The motor is considered to be rotated steady and TGON signal is output when the speed of motor surpassed the set value of the parameter.	
Pn504	Offset counter overflow alarm	No need	P	It is considered that offset counter alarm occur and alarm signal is output when the value of offset counter is larger than the set value of the parameter.	

Pa. No.	Name	Need Repower on	effective control mode	Function and meaning
Pn505	Servo-on waiting time	No need	P, S, T	<p>These parameters are only valid when there is BK output set by end output parameter.</p> <p>These parameters are used to keep braking(prevent from gravity glissade or continuous outside force on motor) time sequence</p> <p>Servo on waiting time</p> <p>BK signal is output at first when servo-on is input, then motor stimulant signal is created after the parameter setting time is delayed.</p> <p>The basic waiting course</p> <p>The standard is: BK output (braking motion) servo-off at the same time. Now, the machine moves a little sometimes caused by gravity, because of the machine's constitution and characters of braking. Now the movement can be eliminated by using user constant relay servo-off motion. The parameter can only be valid when the motor is stop or at low speed.</p> <p>Braking waiting speed</p> <p>BK signal is output when the speed of motor after servo off is dropped below the set value of the parameter.</p> <p>Braking waiting time</p> <p>BK signal is output when they delayed after servo off surpassed the set value of the parameter.</p> <p>The BK signal can be output either the barking waiting speed or the braking waiting time is met.</p>
Pn506	Basic waiting course	No need	P, S, T	
Pn507	Braking waiting speed	No need	P, S, T	
Pn508	Braking waiting time	No need	P, S, T	
Pn509	Match the interface to signals	Need	P, S, T	<p>Pn509.0 corresponding to 1CN_14</p> <p>Pn509.1 corresponding to 1CN_15</p> <p>Pn509.2 corresponding to 1CN_16</p> <p>Pn509.3 corresponding to 1CN_17</p> <p>Pn510.0 corresponding to 1CN_39</p> <p>Pn510.1 corresponding to 1CN_40</p> <p>Pn510.2 corresponding to 1CN_41</p> <p>Pn510.3 corresponding to 1CN_42</p> <p>Every data's corresponding signal is as followings:</p> <p>0: S-ON</p> <p>1: P-CON</p> <p>2: P-OT</p> <p>3: N-OT</p>

Pa. No.	Name	Need Repower on	effective control mode	Function and meaning
Pn510	Match the interface to signals	Need	P, S, T	4: ALMRST 5: CLR 6: P-CL 7: N-CL 8: G-SEL 9: JDPOS-JOG+ A: JDPOS-JOG- B: JDPOS-HALT C:HOME(only effective under CANopen mode)
Pn511	Match the output signals to signals	Need	P, S, T	Pn511.0 corresponding interface 1CN_11 , 1CN_12 Pn511.1 corresponding interface 1CN_07 , 1CN_08 Pn511.2 corresponding interface 1CN_09 , 1CN_10 Every data's corresponding signal is as followings: 0: COIN/VCMP 1: TGON 2: S-RDY 3: CLT 4: BK
Pn512	Bus control input node low bit enable	No need	P, S, T	Bus communication input interface enable [0]: no enable [1]: enable Pn512.0→1CN_14 Pn512.1→1CN_15 Pn512.2→1CN_16 Pn512.3→1CN_17
Pn513	Bus control input node high bit enable	No need	P, S, T	Pn513.0→1CN_39 Pn513.1→1CN_40 Pn513.2→1CN_41 Pn513.3→1CN_42
Pn514	input end filtering	No need	P, S, T	Input end filtering time, too long set time will make the input end signal delay.
Pn515	Reserved		P, S, T	For manufactures
Pn516	Input end signal negate	No need	P, S, T	[0]: No negate [1]: Negate Pn516.0→1CN_14 Negate Pn516.1→1CN_15 Negate Pn516.2→1CN_16 Negate

Pa. No.	Name	Need Repower on	effective control mode	Function and meaning
Pn517	Output end signal negate	No need	P, S, T	Pn516.3→1CN_17 Negate Pn517.0→1CN_39 Negate Pn517.1→1CN_40 Negate Pn517.2→1CN_41 Negate Pn517.3→1CN_42 Negate
Pn518	Reserved	No need	P, S, T	For manufacture
Pn519	Reserved	No need	P, S, T	For manufacture
Pn520	Reserved	No need	P	For manufacture
Pn600	JPOS0 point position control position pulse	No need	P	The two parameters are used combinedly, their algebraic sum is the position that JPOS0's point position need to reach(How many rounds the real motor really rotate is relevant to the programming mode when point position control) Pn602 unit: 10000P Pn603 unit: 1P
Pn601	JPOS0 point position control position pulse	No need	P	
			Other point position parameters mean same
Pn630	JPOS15 point position control mode pulse	No need	P	The two parameters are used combinedly, their algebraic sum is the position that JPOS0's point position need to reach(How many rounds the real motor really rotate is relevant to the programming mode when point position control) Pn630 unit: 10000P Pn631 unit: 1P
Pn631	JPOS15 point position control mode pulse	No need	P	
Pn632	JPOS0 point position speed control	No need	P	JPOS0 point position control speed unit: rpm
			other point position control speed

Pa. No.	Name	Need Repower on	effective control mode	Function and meaning
Pn647	JPOS15 point position speed control	No need	P	JPOS15 point position control speed Unit: rpm
Pn648	JPOS0 point position once filtering	No need	P	JPOS0 Point position control's once filtering time, it makes motor start-stop More tender
			other point position's once filtering
Pn663	JPOS15 point position once filtering	No need	P	JPOS15 Point position control's once filtering time, it makes motor start-stop More tender
Pn664	JPOS0 point position stop time	No need	P	JPOS0 point position control's stop time unit : 50ms
			other point position control stop time
Pn679	JPOS15 闻 point position stop time	No need	P	JPOS15 point position control stop time unit : 50ms
Pn680	Reserved			
Pn681	Hex	No need	P	Pn681.0 once/recycle, start/reference point selection [0] recycle run, PCL start signal, NCL forward direction search reference point. [1] once run, PCL start signal, NCL forward direction search reference point. [2] recycle run, NCL start signal, PCL forward direction search reference point. [3] once run, NCL start signal, PCL forward direction search reference point. Pn681.1 change step and start mode [0] Change step delay, no need of start signal, star

Pa. No.	Name	Need Repower on	effective control mode	Function and meaning
				<p>t delay after S-ON.</p> <p>[1] PCON change step, no need of start signal, PCON start delay after S-ON, but inside pulse can not stop when PCON off.</p> <p>[2] Change step delay, need start signal, canceling start signal can immediately shut down inside pulse, turn back to programme start point process step when reset.</p> <p>[3] Change PCON step , need start signal, canceling start signal can immediately shut down inside pulse, turn back to programme start point process step when reset.</p> <p>Pn681.2 Change step input signal valid mode [0] Change step input signal electrical level mode [1] Change step input signal pulse mode Pn681.3 Reserved</p>
Pn682	programming mode	No need	P	[0]: Incremental programming [1]: Absolute programming
Pn683	programming start step	No need	P	Select the start point of point position control
Pn684	programming stop step	No need	P	Select the stop point of point position control
Pn685	Search travel speed	No need	P	Search the travel switch forward direction reference point's motor speed.
Pn686	leave travel switch speed	No need	P	Search the travel switch backward direction reference point's motor speed.
Pn687	Teaching position pulse	No need	P	If these two parameters are used combinedly, their algebraic sum is the present position of teaching, the two parameters' algebraic sum will be given to present position at the assistant function teaching Pn600 unit: 10000P Pn601 unit: 1P
Pn688	Teaching position pu	No need	P	

Pa. No.	Name	Need Repower on	effective control mode	Function and meaning
	lse			
Pn700	Hex	Need	ALL	Pn700.0 MODBUS Communication baud rate [0] 4800bps [1] 9600bps [2] 19200bps Pn700.1 communication protocols selection [0] 7, N, 2 (Modbus,ASCII) [1] 7, E, 1 (Modbus,ASCII) [2] 7, O, 1 (Modbus,ASCII) [3] 8, N, 2 (Modbus,ASCII) [4] 8, E, 1 (Modbus,ASCII) [5] 8, O, 1 (Modbus,ASCII) [6] 8, N, 2 (Modbus,RTU) [7] 8, E, 1 (Modbus,RTU) [8] 8, O, 1 (Modbus,RTU) Pn700.2 communication protocols selection [0] No protocol SCI communication [1] MODBUS SC communication Pn700.3 Reserved
Pn701	MODBUS axis address	Need	ALL	The axis address when MODBUS protocols communication
Pn702	Reserved			
Pn703	Hex	Need	ALL	Pn703.0 CANopen Communication baud rate [0] 50Kbps [1] 100Kbps [2] 125Kbps [3] 250Kbps [4] 500Kbps [5] 1Mbps Pn703.1 Reserved Pn703.2 Reserved Pn703.3 Reserved
Pn704	MODBUS axis address	Need	ALL	The axis address when CANopen communication

If the selected driver is BUS mode, the pulse input and analog input are invalid. The motor is controlled by bus circular data at this moment. If controlling motor speed is needed, the control mode can be set to analog instruction speed control. It equals to use bus data directly to indicate speed instruction now while using analog to match speed before. And now, the other functions are the same with No bus control.

Appendix

List of Alarm Display

List of Alarm Display

Alarm display	Alarm output	Alarm Name	Instruction
A. 01	×	Parameter breakdown	Checksum results of parameters are abnormal.
A. 02	×	A/D shift channels breakdown	AD relevant electrical circuit damaged
A. 03	×	Overspeed	Motor is out of control
A. 04	×	Overload	Continuous running when surpass the rated torque
A. 05	×	Position error counter overflow	Internal counter overflow
A. 06	×	position error pulse overflow	Position error pulse exceeded the value set in parameter Pn-036
A. 07	×	The setting of electrical gear and setting of given pulse frequency are not reasonable	Electronic gear setting is not reasonable or pulse frequency is too high
A. 08	×	Something wrong with the first tunnel of current sense	Something wrong with inside chip of the first tunnel
A. 09	×	Something wrong with the second tunnel of current sense	Something wrong with inside chip of the second tunnel
A. 10	×	Encoder PA , PB or PC disconnected	At least one of PA, PB or PC is disconnected
A. 11	×	Encoder PU , PV or PW disconnected	At least one of PU, PV or PW is disconnected
A. 12	×	Overcurrent	An overcurrent flowed through the IPM module.
A. 13	×	Overvoltage	Main electrical circuit voltage for motor running is too high.
A. 14	×	Undervoltage	Main electrical circuit voltage for motor running is too low.
A. 15	×	Bleeder resistor damaged	Bleeder resistor is damaged
A. 16	×	Regenerative error	Regenerative circuit error

A. 20	×	Power lines Open phase	One phase is not connected in The main circuit power supply
A. 21	×	instantaneous power off alarm	More than one power cycle's off in alternating current .
A. 30	×	Encoder UVW illegal code	U,V, W all "1" or "0"
A. 31	×	Encoder UVW wrong code	U,V,W code sequence is fault
A. 32	×	Encoder C pulse is not correct	C pulse appears in wrong position
A. 33	×	Encoder has no C pulse	No C pulse appeared after encoder rotated for one round.
A. 41	×	reserved	reserved
A. 42	×	reserved	reserved
A. 43	×	The model of servo and motor is not correct.	Servo parameter is not match with motor.
A. 44	×	reserved	reserved
A. 45	×	Absolute encoder multi-loop message	Multi-loop message is not correct.
A. 46	×	Absoluteencoder multi-loop message overflow	Multi-loop message overflow
A. 47	×	Battery voltage below 2.5V	Multi-loop message disappeared
A. 48	×	Battery volatage below 3.1V	Battery voltage is too low
A. 50	×	Encoder communication over time	Encoder disconnect, encoder signal is disturbed, encoder damaged or encoder decode electric circuit damaged
A. 51	×	No power supply absolute encoder rotated speed over 100rpm	Multi-loop message may error.
A. 52	×	Encoder absolute state is wrong	Encoder or encoder decode electric circuit is damaged
A. 53	×	Encoder count error	Encoder or encoder decode electric circuit is damaged
A. 54	×	Encoder control field parity bit, cut off bit error.	Encoder signal is disturbed or encoder decode electric circuit is damaged
A. 55	×	Encoder communication datum verify error	Encoder signal is disturbed or encoder decode electric circuit is damaged

A. 56	×	Encoder status field cut off point error	Encoder signal is disturbed or encoder decode electric circuit is damaged
A. 58	×	No serial encoder datum	No serial encoder EEPROM datum
A. 59	×	Serial encoder data form error	Serial encoder EEPROM data form is not correct
A. 60	×	Can not detect communication module	No communication module or something wrong with communication module
A. 61	×	Can not managed to connect with communication module	Communication module CPU does not work well
A. 62	×	drive can not receive circular data from communication module	something wrong with the drive data receiving tunnel or communication module sending tunnel
A. 63	×	The communication module can not receive the drive's response data	Something wrong with communication module
A. 64	×	No connection between communication module and bus	Bus communication is abnormal
A. 00	○	No error display	Display normal motion state

○: Output transistor=Open(ON)

×: Output transistor=Cut off(Alarm state)(OFF)

A. 45, A. 46, A. 47, A.51 will recover the alarm when need to clear the absolute arm.For multi-loop message is not correct, so often need to set the multi-loop zero.