

## **LAMPIRAN A**

Program pada arduino uno ..... A-1

```

#include <NewSoftSerial.h>
#include <SDCameraC328R.h>

void getJPEGPicture_callback(uint16_t pictureSize, uint16_t packageSize, uint16_t
packageCount, byte * package);
void blink(int times);
int sync_camera(void);

int ledPin = 2;
int PIRPin = 3;

SDCameraC328R camera;

void setup()
{
pinMode(ledPin, OUTPUT);           // Set Pin 2 sebagai output untuk LED
pinMode(PIRPin, INPUT);           // Set Pin 3 sebagai input dari PIR

digitalWrite(ledPin, HIGH);       // Set LED dalam posisi ON (Penanda Awal
Inisialisasi)
int retval = 0;                   // Deklarasi variabel retval = 0

Serial.begin(57600);              // Set Baudrate komunikasi serial=57600
retval = camera.InitializeSD();    // Inisialisasi SD Card
if (retval != 0) blink(retval);   // Jika Error tandai dengan kedipan LED

retval = sync_camera();           // Inisialisasi Kamera
if (retval != 0) blink(retval);   // Jika Error tandai dengan kedipan LED

digitalWrite(ledPin, LOW);        // Set LED dalam posisi OFF (Penanda Akhir
Inisialisasi)
}

void loop()
{
for (uint16_t i=0; i<1000; i++) {
int retval = 0;                   // Deklarasi variabel retval = 0
retval = digitalRead(PIRPin);     // Baca nilai dari PIR
if (retval == HIGH) {            // Jika terdeteksi gerakan
digitalWrite(ledPin, HIGH);      // Set LED dalam posisi ON

retval = sync_camera();           // Inisialisasi Kamera
if (retval != 0) blink(retval);   // Jika Error tandai dengan kedipan LED

sprintf(camera.filename, "TA0422079-%05d.jpg", i);
// Persiapkan file penampung

retval = camera.snapshot(SDCameraC328R::ST_COMPRESSED, 0);
if (retval != 0) blink(retval);   // Lakukan pengambilan gambar
// kompres ke dalam JPEG
// Jika Error tandai dengan kedipan LED
retval = camera.getJPEGPicture(SDCameraC328R::PT_JPEG, PROCESS_DELAY,
&getJPEGPicture_callback);
if (retval != 0) blink(retval);   // Ambil gambar dari kamera dan
simpan ke dalam SD Card
// Jika Error tandai dengan kedipan LED

delay(500);
digitalWrite(ledPin, LOW);        // Set LED dalam posisi OFF

} else {
digitalWrite(ledPin, LOW);        // Set LED dalam posisi OFF
}
}
}

```

```
// Fungsi getJPEGPicture_callback
// Dipanggil setiap kali paket data JPEG diterima
// (not used)
void
getJPEGPicture_callback(uint16_t pictureSize, uint16_t packageSize,
                        uint16_t packageCount, byte * package)
{
// Digunakan untuk melakukan fungsi lain selain menyimpan ke dalam SDCard
}

// Fungsi blink
// Digunakan untuk mengedipkan LED sebanyak kode Error
void blink(int err)
{
if (!err)
    return;
while (1) {
    for (int i = 0; i < err; i++) {
        digitalWrite(ledPin, HIGH);
        delay(200);
        digitalWrite(ledPin, LOW);
        delay(200);
    }
    delay(1000);
}
}
```

```

// Fungsi sync_camera
// Digunakan untuk mempersiapkan kamera
// (Setting mode kerja kamera)
//
// return values:
//          0 - success
//          ERRCODE - camera sync errorcode
int sync_camera()
{
int retval = 0;
retval = camera.sync();
if (retval != 0)
    return (retval);

retval = camera.initial(SDCameraC328R::CT_JPEG, SDCameraC328R::PR_80x60,
                        SDCameraC328R::JR_640x480);
if (retval != 0) blink(retval);          // Set kamera (ColorType,
                                        PreviewResolution, JPEGResolution)
                                        // Jika Error tandai dengan kedipan LED

retval = camera.setPackageSize(100);
if (retval != 0)
    return (retval);

retval = camera.setLightFrequency(SDCameraC328R::FT_50Hz);
if (retval != 0)
    return (retval);

    delay(2000);
    return retval;
}

```

## **LAMPIRAN B**

Data Sheet Camera C328 ..... B-1

Data Sheet Sensor PIR ..... B-2

### General Description

The C328-7640 is VGA camera module performs as a JPEG compressed still camera and can be attached to a wireless or PDA host. Users can send out a snapshot command from the host in order to capture a full resolution single-frame still picture. The picture is then compressed by the JPEG engine and transferred to the host thru serial port.

### Block Diagram

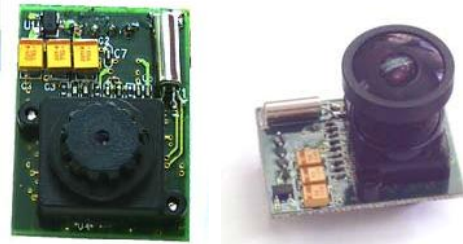
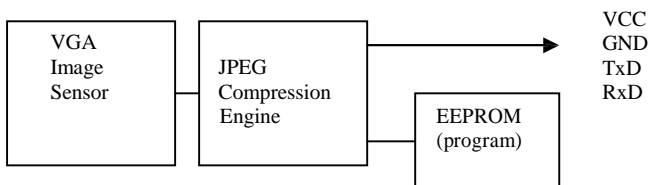

### Features

- Small in size, 20x28mm
- VGA resolution, down sample to QVGA or CIF
- 3.3V operation
- Low power consumption 60mA
- User friendly commands to control the module
- UART interface of up to 115.2Kbps
- Auto detect baud rate and make connection to the host
- Power saving mode
- Various lens options

### Pin Description

Pin	Description
VCC	Power 3.3VDC
TxD	Data Transmit (3.3V)
RxD	Data Receive (3.3V)
GND	Power Ground

Connector specification: 2mm pitch, 4pin single row

Reference part no: Suyin 190600

Mating connector: Suyin 140600

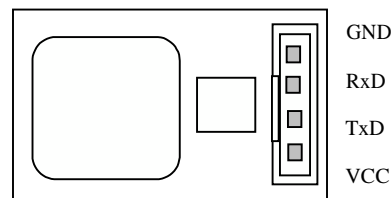

Bottom View

### Command Summary

Detail Command control, please refer to the user's manual

1.	Initial	To configure the image size, color type
2.	Get Picture	Get Picture type
3.	Snapshot	Set snap shot image type
4.	Set Package Size	Set the package size to transmit data from module to Host
5.	Set Baudrate	Change the baud rate
6.	Reset	Reset the whole system or reset the state machine
7.	Power Off	To enter sleep mode
8.	Data	Set the data type and length for transmitting data to host
9.	SYNC	Sync signal to connect between host and module
10.	ACK	Command to indicate the communication success
11.	NAK	Command to indicate the communication fail with error code

## Electrical Specification

$V_{DD} = 3.3V \pm 10\%$ ,  $T_A = 0$  to  $25^\circ C$

Symbol	Parameter	Condition	Min	Typ	Max	Unit
$V_{DD}$	DC supply voltage		3.0	3.3	3.6	V
$I_o$	Normal Operation Current	Operating		60		mA
$I_s$	Suspend Current	Suspend		100		uA
$V_{IH}$	High level input voltage	TTL	2.0			V
$V_{IL}$	Low level input voltage	TTL			0.8	V

## Lens Specification

Description	C328-7640	C328-2225BW	C328-2520BW	C328-3620IR	C328-3620BW	C328-6016BW	C328-6016IR
F/#	2.8	2.5	2.0	2.0	2.0	1.6	1.6
Focal length (mm)	4.63	2.2	2.5	3.6	3.6	6.0	6.0
Field of View Diagonal (deg)	57	118	100	66	66	36	36
Filter Option IR-cut filter	Yes	NA	NA	Yes	NA	NA	Yes
Total height from PCB H (mm)	10	18	24	22	22	20	20
Diameter of lens cap D (mm)	9	18	15	14	14	14	14

## Board Measurement

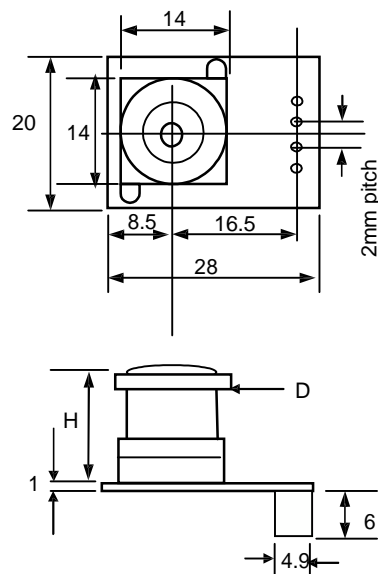

Note: All lens holder are with 14x14, thread of 12mmx0.5, height H will be varied from different lens spec.



Note: In order to facilitate people for better understanding the communication with the module, we have developed an EV kit, C328-EV232, for user to run under PC Windows environment. However, this module is not designed for PC application. Such PC evaluation is only for better understanding of command control.

## Information of Alternative Lens solution for C328

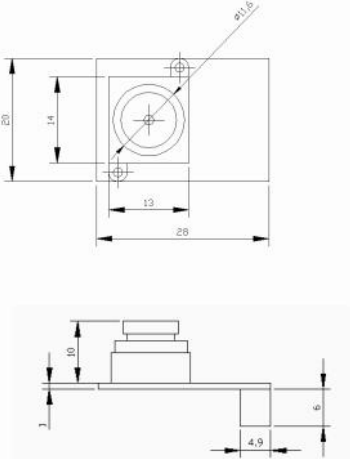
**Note: we suggest to use lens of IR cut filter built-in for outdoor application.**

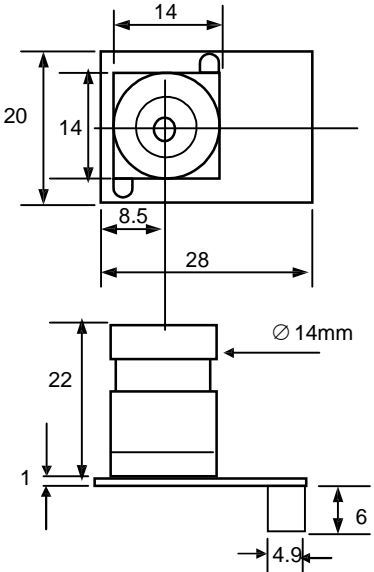
<p>C328-7640 Standard configuration</p> 		<p>Detail spec and dimension, pls refer to the spec sheet of C328</p> <p>F/No 2.8  <math>f = 4.63\text{mm}</math>          FOV <math>57^\circ</math> diagonal          IR cut filter built-in</p>
<p>C328-3620BW/IR          No IR cut filter on the lens</p> 		<p>F/No 2.0  <math>f = 3.6\text{mm}</math>          FOV <math>= 66^\circ</math> diagonal</p>



C328-2225BW  
No IR cut filter on the lens

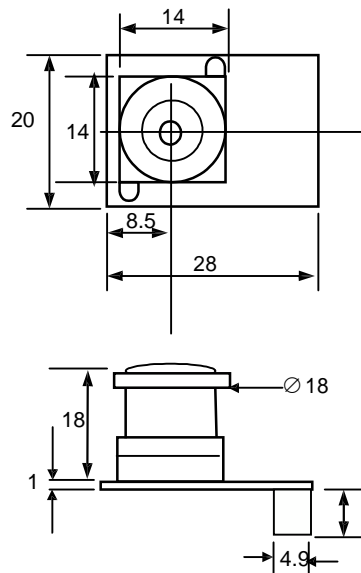

F/No 2.5  
f=2.2mm  
FOV=118° diagonal

C328-2520BW  
No IR cut filter on the lens

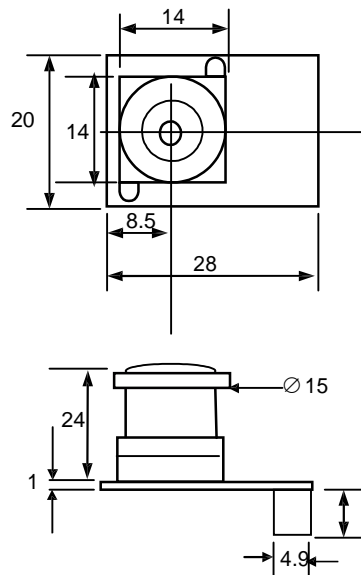

F/No 2.0  
f=2.5mm  
FOV=100° diagonal

C328-6016BW/IR  
No IR cut filter on the lens

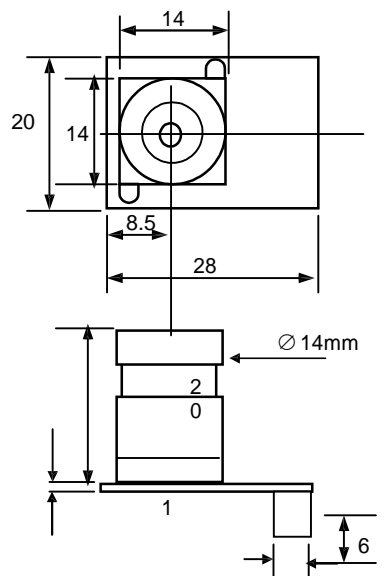

F/No 1.6  
f=6.0mm  
FOV=36° diagonal

## **C328-7640 User Manual**

### **Release Note:**

- 1. Jan 28, 2004 – official released v1.0**
- 2. Feb 24, 2004 – official released v1.1**
  - y **Fix the definition of verify code**
  - y **Fix the bug of unable jump to power save mode**
  - y **Fix the incorrect connection speed after wake up from power save mode**
- 3. Apr 24, 2004 – official released v2.0**
  - y **Add auto baud-rate detection**
  - y **Add support of 9600bps, 19200bps, 38400bps**
  - y **Disable the 8-bit colour for uncompressed picture**
- 4. Apr 12, 2005 – official released v2.1**
  - y **Add command to change the light frequency between 50/60 Hz**
  - y **Add more descriptions of the resolution selection**
- 5. Aug 19, 2005 – official released v3.0**
  - y **Add description of the auto power mode**
  - y **Add FAQ section**



Rm 802, Nan Fung Ctr, Castle Peak Rd, Tsuen Wan NT, Hong Kong

Tel: (852) 2498 6248

Fax (852) 2414 3050

Email: [sales@comedia.com.hk](mailto:sales@comedia.com.hk)

<http://www.comedia.com.hk>

## **General Description**

The C328 module is a highly integrated serial camera board that can be attached to a wireless or PDA host performing as a video camera or a JPEG compressed still camera. It provides a serial interface (RS-232) and JPEG compression engine to act as a low cost and low powered camera module for high-resolution serial bus security system or PDA accessory applications.

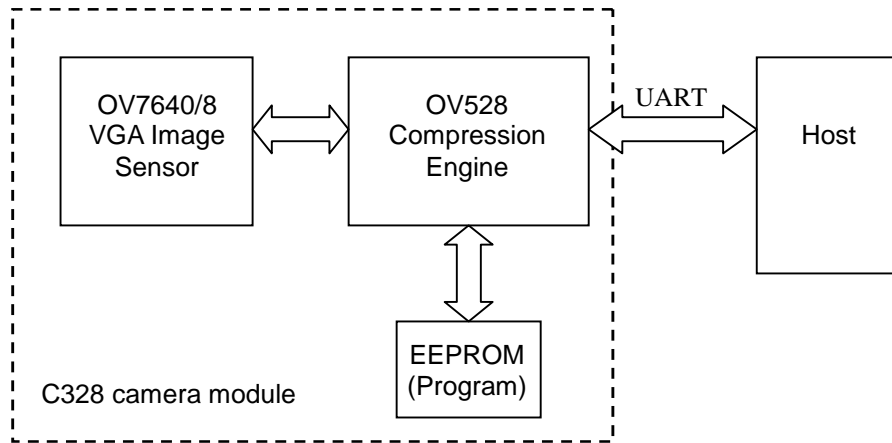

Figure 1 – System block diagram

## **Features**

- ¾ Small in size, low cost and low powered (3.3V) camera module for high-resolution serial bus security system or PDA accessory applications.
- ¾ On-board EEPROM provides a command-based interface to external host via RS-232.
- ¾ UART: 115.2Kbps for transferring JPEG still pictures or 160x128 preview @8bpp with 0.75fps.
- ¾ On board OmniVision OV7640/8 VGA color sensor.
- ¾ Built-in JPEG CODEC for different resolutions.
- ¾ Built-in down sampling, clamping and windowing circuits for VGA, QVGA, 160x120 or 80x60 image resolutions.
- ¾ Built-in color conversion circuits for 2-bit gray, 4-bit gray, 8-bit gray, 12-bit RGB, 16-bit RGB or standard JPEG preview images.
- ¾ No external DRAM required.

## **System Configuration**

1. Camera Sensor  
The C328-7640 module uses OmniVision OV7640/8 VGA color digital CameraChips with an 8-bit YCbCr interface.
2. OV528 Serial Bridge  
The OV528 Serial Bridge is a JPEG CODEC embedded controller chip that can compress and transfer image data from CameraChips to external device. The OV528 takes 8-bit YCbCr 422 progressive video data from an OV7640/8 CameraChip. The camera interface synchronizes with input video data and performs down sampling, clamping and windowing functions with desired resolution, as well as color conversion that is requested by the user through serial bus host commands.  
The JPEG CODEC can achieve higher compression ratio and better image quality for various image resolutions.
3. Program EEPROM  
A serial type program memory is built-in for C328-7640 to provide a set of user-friendly command interfacing to external host.

## Board Layout

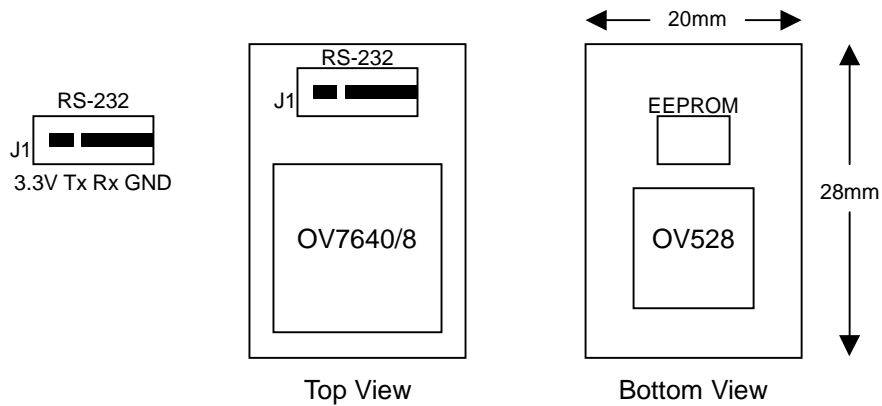

Figure 2 – C328-7640 board layout and serial interface pin

## Serial Interface

### 1. Single Byte Timing Diagram

A single byte RS-232 transmission consists of the start bit, 8-bit contents and the stop bit. A start bit is always 0, while a stop bit is always 1. LSB is sent out first and is right after the start bit.

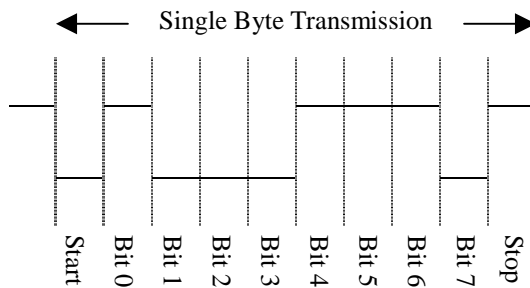

Figure 3 – RS-232 single byte timing diagram

### 2. Command Timing Diagram

A single command consists of 6 continuous single byte RS-232 transmissions. The following is an example of SYNC (AA0D0000000h) command.

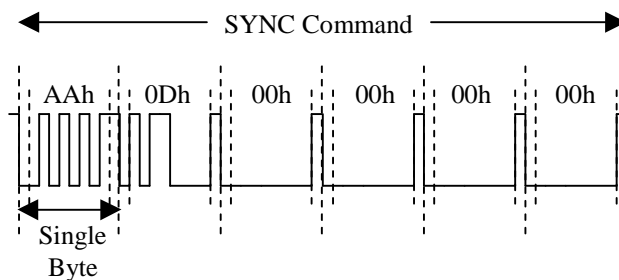

Figure 4 – RS-232 SYNC command timing diagram

## **Command Set**

The C328-7640 module supports total 11 commands for interfacing to host as following:

<b>Command</b>	<b>ID Number</b>	<b>Parameter1</b>	<b>Parameter2</b>	<b>Parameter3</b>	<b>Parameter4</b>
Initial	AA01h	00h	Color Type	RAW Resolution (Still image only)	JPEG Resolution
Get Picture	AA04h	Picture Type	00h	00h	00h
Snapshot	AA05h	Snapshot Type	Skip Frame Low Byte	Skip Frame High Byte	00h
Set Package Size	AA06h	08h	Package Size Low Byte	Package Size High Byte	00h
Set Baudrate	AA07h	1st Divider	2nd Divider	00h	00h
Reset	AA08h	Reset Type	00h	00h	xxh*
Power Off	AA09h	00h	00h	00h	00h
Data	AA0Ah	Data Type	Length Byte 0	Length Byte 1	Length Byte 2
SYNC	AA0Dh	00h	00h	00h	00h
ACK	AA0Eh	Command ID	ACK counter	00h / Package ID Byte 0	00h / Package ID Byte 1
NAK	AA0Fh	00h	NAK counter	Error Number	00h
Light Frequency	AA13h	Frequency Type	00h	00h	00h

\* If the parameter is 0xFF, the command is a special Reset command and the firmware responds to it immediately.

### **1. Initial (AA01h)**

The host issues this command to configure the preview image size and color type. After receiving this command, the module will send out an ACK command to the host if the configuration success. Otherwise, an NACK command will be sent out.

#### **1.1 Color Type**

C328-7640 can support 7 different color types as follow:

2-bit Gray Scale	01h
4-bit Gray Scale	02h
8-bit Gray Scale	03h
12-bit Color	05h
16-bit Color	06h
JPEG	07h

#### **1.2 Preview Resolution**

80x60	01h
160x120	03h

#### **1.3 JPEG Resolution**

Since the Embedded JPEG Code can support only multiple of 16, the JPEG preview mode can support following image sizes. It is different from normal preview mode.

80x64	01h
160x128	03h
320x240	05h
640x480	07h

## 2. Get Picture (AA04h)

The host gets a picture from C328-7640 by sending this command.

### 2.1 Picture Type

Snapshot Picture	01h
Preview Picture	02h
JPEG Preview Picture	05h

## 3. Snapshot (AA05h)

C328-7640 keeps a single frame of JPEG still picture data in the buffer after receiving this command.

### 3.1 Snapshot Type

Compressed Picture	00h
Uncompressed Picture	01h

### 3.2 Skip Frame Counter

The number of dropped frames can be defined before compression occurs. "0" keeps the current frame, "1" captures the next frame, and so forth.

## 4. Set Package Size (AA06h)

The host issues this command to change the size of data package which is used to transmit JPEG image data from the C328-7640 to the host. This command should be issued before sending Snapshot command or Get Picture command to C328-7640. It is noted that the size of the last package varies for different image.

### 4.1 Package Size

The default size is 64 bytes and the maximum size is 512 bytes.



ID -> Package ID, starts from zero for an image

Data Size -> Size of image data in the package

Verify Code -> Error detection code, equals to the lower byte of sum of the whole package data except the verify code field. The higher byte of this code is always zero. i.e. verify code = lowbyte(sum(byte[0] to byte[N-2]))

Note: As the transmission of uncompressed image is not in package mode, it is not necessary to set the package size for uncompressed image.

## 5. Set Baudrate (AA07h)

Set the C328-7640 baud rate by issuing this command. As the module can auto-detect the baud rate of the incoming command, host can make connection with one of the following baud rate in the table. The module will keep using the detected baud rate until physically power off

### 5.1 Baudrate Divider

Baudrate =  $14.7456\text{MHz} / 2 \times (2^{\text{nd}} \text{ Divider} + 1) / 2 \times (1^{\text{st}} \text{ Divider} + 1)$

Baudrate	1 <sup>st</sup> Divider	2 <sup>nd</sup> Divider	Baudrate	1 <sup>st</sup> Divider	2 <sup>nd</sup> Divider
7200 bps	ffh	01h	28800 bps	3fh	01h
9600 bps	bffh	01h	38400 bps	2fh	01h
14400 bps	7fh	01h	57600 bps	1fh	01h
19200 bps	5fh	01h	115200 bps	0fh	01h

## 6. Reset (AA08h)

The host reset C328-7640 by issuing this command.

### 6.1 Reset Type

“00h” resets the whole system. C328-7640 will reboot and reset all registers and state machines.

“01h” resets state machines only.

## 7. Power Off (AA09h)

C328-7640 will go into sleep mode after receiving this command. SYNC command (AA0Dh) must be sent to wake up C328-7640 for certain period until receiving ACK command from C328-7640.

## 8. Data (AA0Ah)

C328-7640 issues this command for telling the host the type and the size of the image data which is ready for transmitting out to the host.

### 8.1 Data Type

Snapshot Picture	01h
Preview Picture	02h
JPEG Preview Picture	05h

### 8.2 Length

These three bytes represent the length of data of the Snapshot Picture, Preview Picture or JPEG Preview Picture.

## 9. SYNC (AA0Dh)

Either the host or the C328-7640 can issue this command to make connection. An ACK command must be sent out after receiving this command.

## 10. ACK (AA0Eh)

This command indicates the success of last operation. After receiving any valid command, ACK command must be sent out except when getting preview data. The host can issue this command to request image data package with desired package ID after receiving Data command from C328-7640. The host should send this command with package ID F0F0h after receiving a package to end the package transfer. Note that the field “command ID” should be 00h when request image data package.

### 10.1 Command ID

The command with that ID is acknowledged by this command.

### 10.2 ACK Counter

No use.

### 10.3 Package ID

For acknowledging Data command, these two bytes represent the requested package ID. While for acknowledging other commands, these two bytes are set to 00h.

## 11. NAK (AA0Fh)

This command indicates corrupted transmission or unsupported features.

### 11.1 NAK Counter

No use.

### 11.2 Error Number

Picture Type Error	01h	Parameter Error	0bh
Picture Up Scale	02h	Send Register Timeout	0ch
Picture Scale Error	03h	Command ID Error	0dh
Unexpected Reply	04h	Picture Not Ready	0fh
Send Picture Timeout	05h	Transfer Package Number Error	10h
Unexpected Command	06h	Set Transfer Package Size Wrong	11h
SRAM JPEG Type Error	07h	Command Header Error	F0h
SRAM JPEG Size Error	08h	Command Length Error	F1h
Picture Format Error	09h	Send Picture Error	F5h
Picture Size Error	0ah	Send Command Error	ffh

## 12. Light Frequency (AA13h)

The host issues this command to change the light frequency of the C328-7640.

### 12.1 Light Frequency Type

50Hz	00h
60Hz	01h



## Command Protocol

### 1. SYNC Command

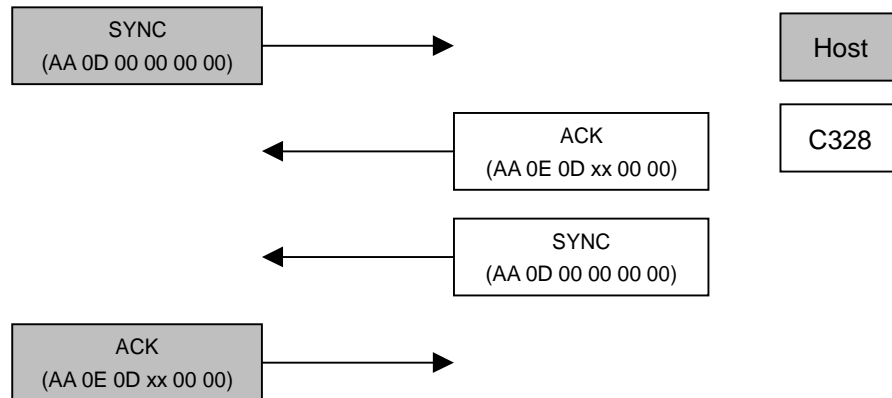

### 2. Make Connection with C328-7640

Send the SYNC command (at 14400bps) until receiving ACK command from C328-7640 (usually an ACK command is receive after sending 25 times of SYNC command). This must be done after power up.

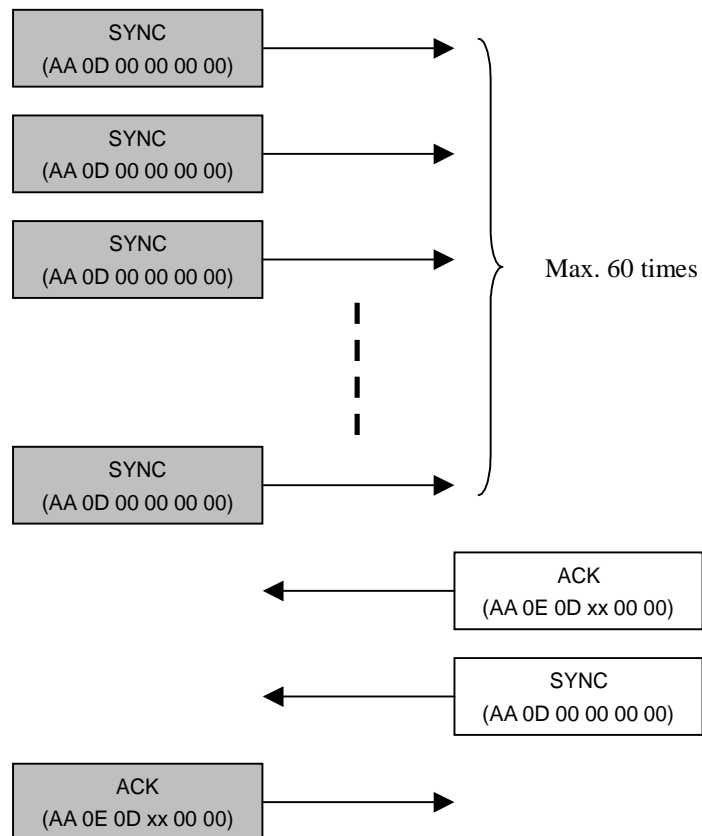

3. Initial, Get Picture, Snapshot, Set Package Size, Set Baudrate, Reset and Power Off Command

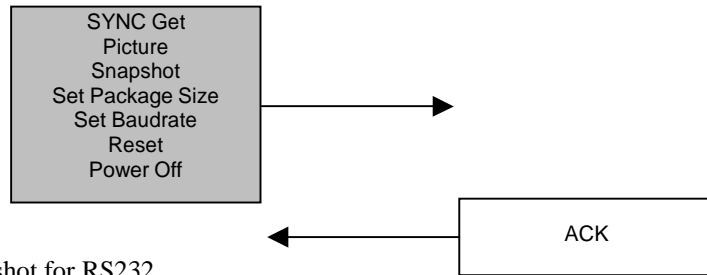

4. Getting a Snapshot for RS232  
Make sure connection is made before the following communication.

4.1 JPEG Snapshot Picture (eg. 640x480 resolution)

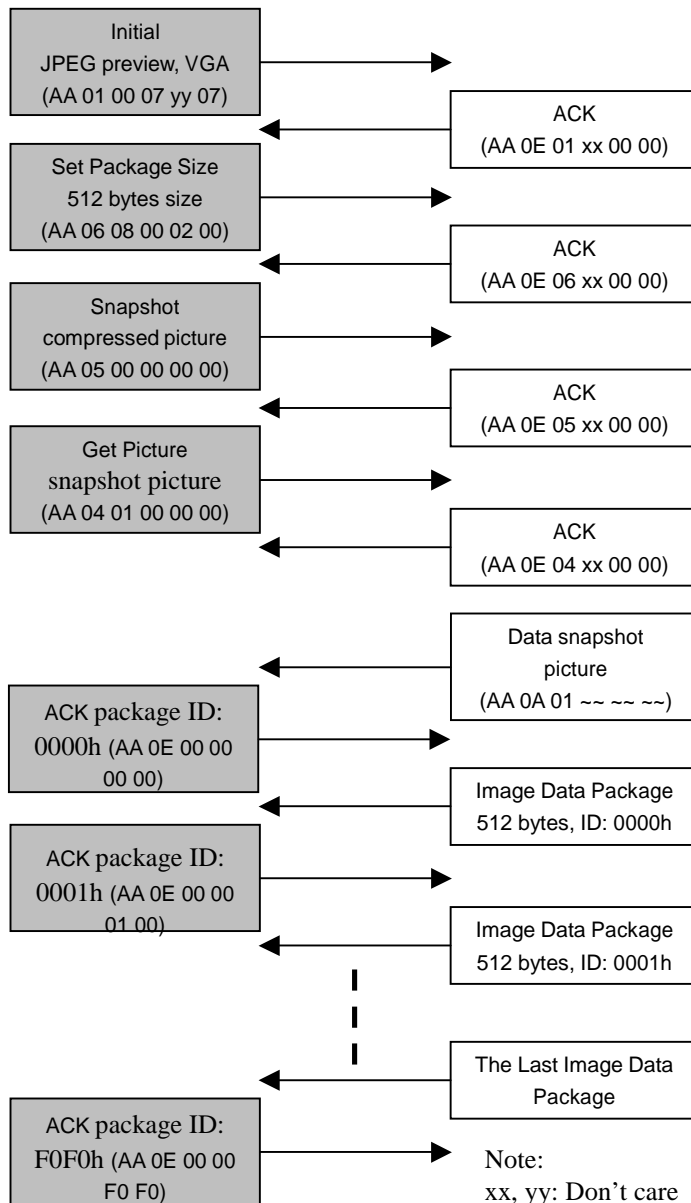

Note:  
xx, yy: Don't care  
~~: Image size returned by C328

#### 4.2 Snapshot Picture (uncompressed snapshot picture)

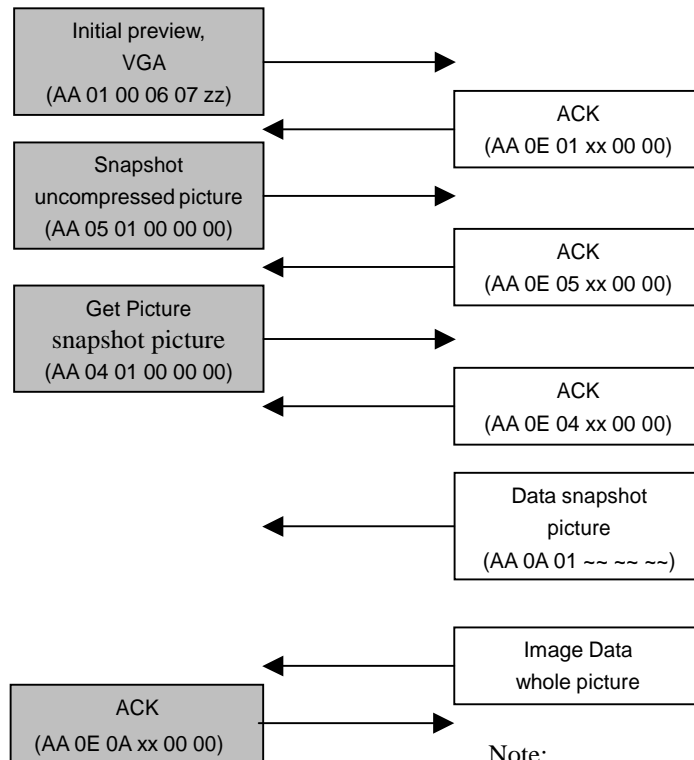

Note:  
 xx, zz : Don't care  
 ~: Image size returned by C328

- 5. Getting JPEG preview pictures (video) for RS232  
Make sure connection is made before the following communication.
- 5.1 JPEG Preview Picture

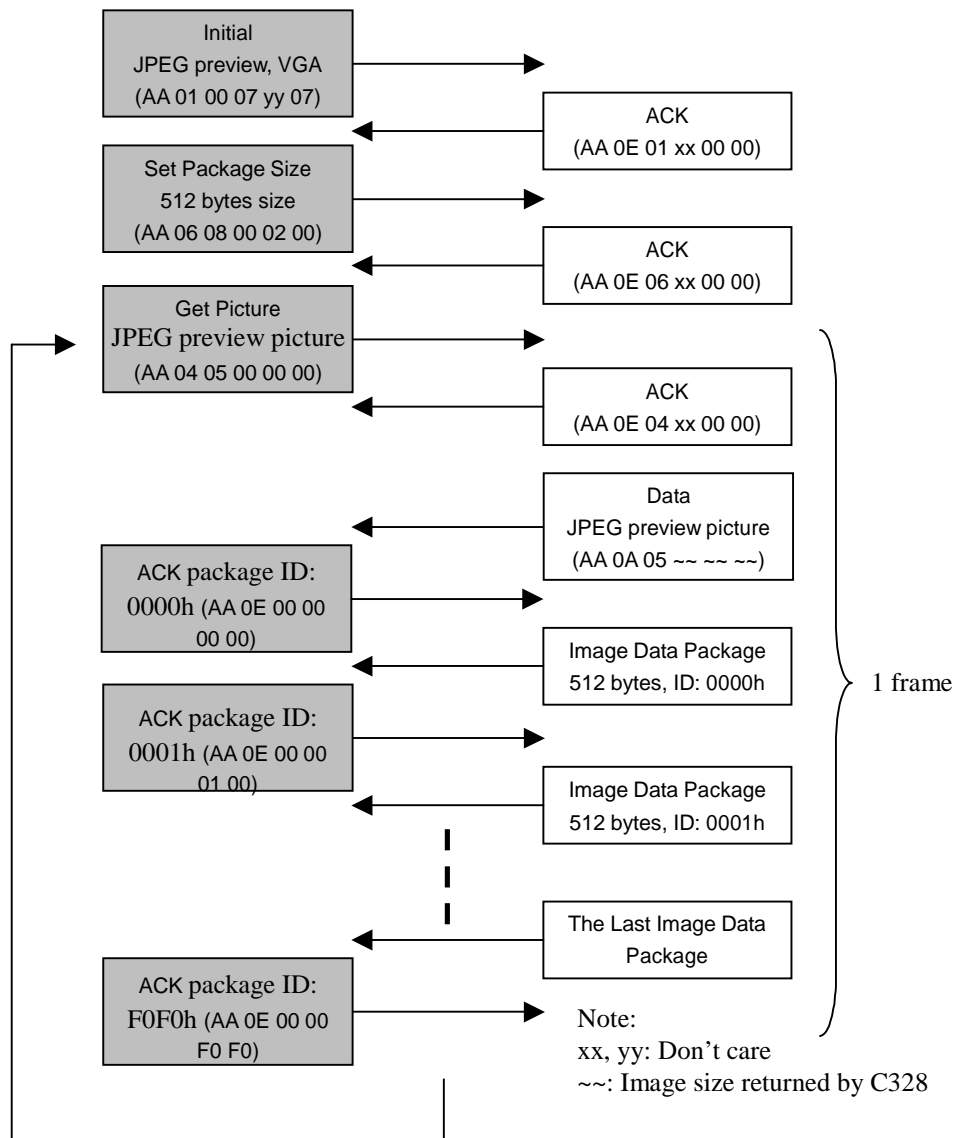

## 5.2 Preview Picture (uncompressed preview picture)

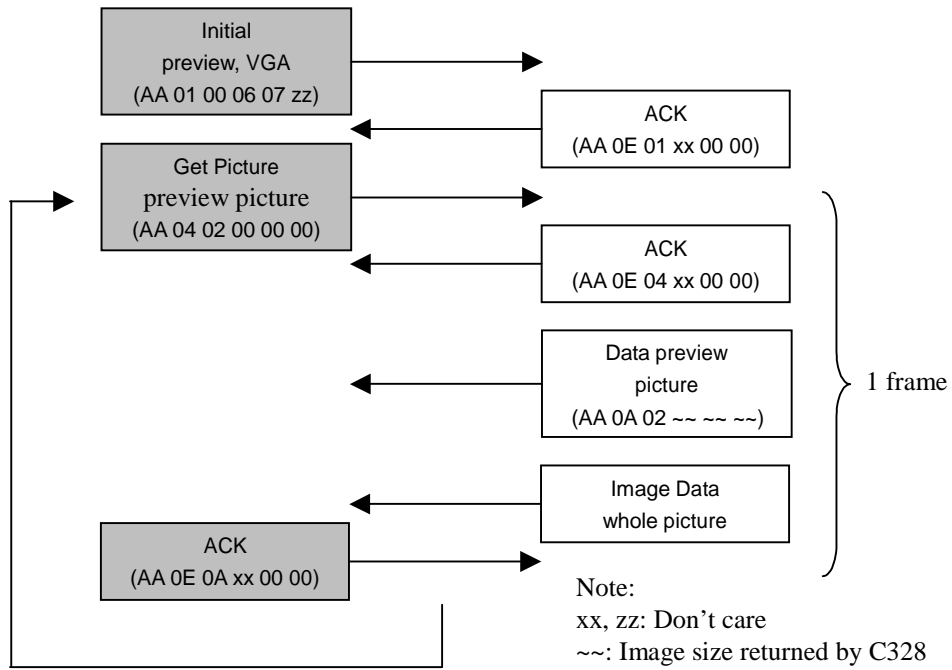

RoHS Compliant

# KC7783R PIR Module Low Cost version

This is a low cost version of the PIR module. It is designed for cost sensitive consumer product.  
Except the IC package format, all the mechanical and electrical spec is same as KC7783.

## Features:

- ... IC soft package by dice bonding technique
- ... Small size: 25 x 35mm
- ... Ball lens is included as standard configuration
- ... 3 leads flat cable for easy connection
- ... 4 mounting holes on board
- ... High Sensitivity
- ... High immunity to RFI
- ... Power up delay to prevent from false triggering
- ... Output High for direct connect to control panel



## Specification

	Min	Typ	Max	Unit
Operation Voltage	4.7	5	12	V
Standby Current ( no load)		300		μA
Output Pulse Width	0.5			Sec
Output High Voltage		5		V
Detection Range		5		M
Operation Temperature	-20	25	50	°C
Humidity Range			95	%

- Note: 1. All other features and specification, please refer to KC778B  
 2. Minimum output pulse width can be customer specified.

## Standard Configuration

PIR controller	KC778B in dice form
PIR Sensor	RE200B by NICERA
Lens	Ball lens of 60° detection angle
Connector	3 leads flat cable, Power, GND, O/P

## Mechanical Dimension

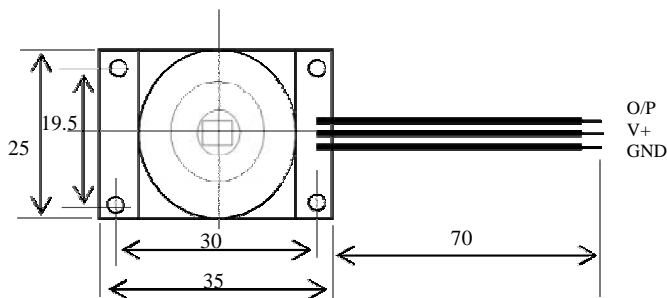

## Lens Dimension (unit in mm)

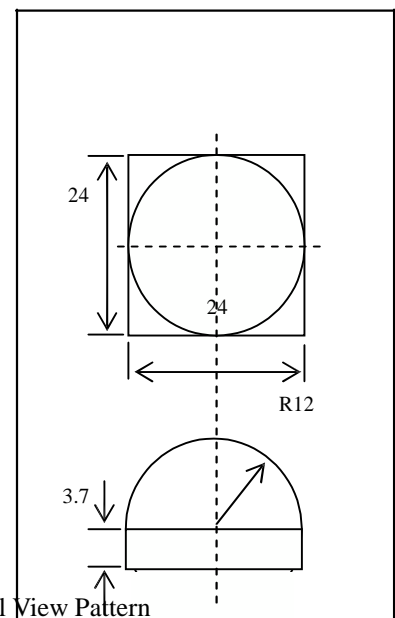

Vertical View Pattern

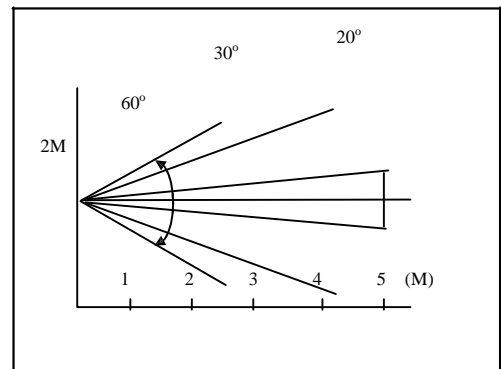

## Application Note:

1. The PIR sensor is sensitive to the temperature change and therefore to prevent from operating the module in rapid environmental temperature changes, strong shock or vibration. Don't expose to the direct sun light or headlights of automobile. Don't expose to direct wind from heater or air conditioner.
2. This module is designed for indoor use. If using in outdoor, make sure to apply suitable supplemental optical filter and drop-proof, anti-dew construction
3. Detection range might be varied in different environmental temperature condition.