

COMMScope®
Andrew Solutions

MT500B SERIES DryLine® DEHYDRATOR

USER MANUAL

Bulletin AE01B-A0555-001
© 2008 - 2012 CommScope, Inc. All rights reserved

Rev: J
(11/12)



Table of Contents

Section 1	General Information	4
1.1	Introduction	4
1.2	Description	4
1.3	Theory of operation	4
1.4	Alarms	5
	Figure 1 - Discrete Alarm Terminal Strip with Summary Alarm	5
	Figure 2 - Summary Alarm Terminal Strip.	5
	Figure 3 - Pin and Jumpers Location.	6
1.5	Specifications MT500B Dehydrator.	6
Section 2	Installation	7
2.1	Unpacking and Inspection	7
2.1.1	Installation Kit Items	7
2.2	Controls and Displays.	7
2.2.1	Event Log Codes.	7
2.3	Installing the Dehydrator	7
2.3.1	19" Rack Mounting or set on optional shelf	7
2.4	Power Connections	7
2.4.1	AC Power.	8
2.4.2	DC Power	8
2.4.3	Test the Dehydrator	8
2.5	Connecting the Alarm Outputs	8
2.6	Connecting Dehydrator to the Transmission Line.	8
2.7	Purging the Transmission Line	9
Section 3	Maintenance	10
3.0	Maintenance	10
3.1	Preventive Maintenance	10
3.2	Dehydrator Filter Element Replacement	10
3.3	Annual Inspection	10
3.3.1	Check the electrical connections.	11
3.3.2	Check the ground wire.. . . .	11
3.3.3	Check the hour meter.	11
3.4	Parts Replacement and Dehydrator Overhaul.	11
3.4.1	In Case Of Difficulty	11
3.4.2	Tools	11
3.4.3	Overhaul Procedure	12
3.4.4	Unit Shutdown and Removal	12
3.4.5	Unplug the unit from the power supply.	12
3.5	Service Restoration RECOMMENDATION:.	12
Section 4	Troubleshooting.	13
	Figure 4 - MT500B-81015 Electrical with Summary Alarm.	14
	Figure 5 - MT500B-81315 Electrical with Discrete Alarm.	15
	Figure 6 - MT500B Pneumatic Diagram.	16

Section 5	Replacement Parts	17
	Overhaul Kit MT500B-KIT-OVRHL	17
	Filter Element Replacement Kit MT500B-KIT-ELMNT.	17
	Filter Bowl Assemble Replacement Kit MT500B-KIT-FLTRS	17
	Filter Bowl Assemble and Dryer Tube Replacement Kit	17
	MT500B-KIT-DRYER	17
	Solenoid Replacement Kit MT500B-KIT-SOLND	17
Section 6	Customer Service	17
	6.0 Introduction	17
	6.1 In Case of Trouble	17
	6.2 Initial Steps by CommScope	18
	6.3 Repair Center Process	18
	6.4 RoHS Inquiries	18
Section 7	DC Inverter Option	19
	7.1 Introduction	19
	7.2 Installing the 24 Vdc to AC inverter	19
	7.3 Installing the 48 Vdc to AC inverter	20

**Section 1
General Information**

1.1 Introduction

This manual contains the information you need to install, operate and maintain your MT500B Series DryLine® Dehydrator. Please take the time to read this manual before attempting to operate or service the unit.

This appliance is not intended for access by the general public.

This appliance is not intended for use by persons (including children) with reduced physical, sensory or mental capabilities, or lack of experience and knowledge, unless they have been given supervision or instruction concerning use of the appliance by a person responsible for their safety.



1.2 Description

MT500B Series dehydrators provide dry air for pressurizing medium (between 283 to 3400 liters (10 and 120 cubic feet), in volume) antenna and transmission line systems. The dehydrators produce -45°C (-50°F) dew point dry air at a nominal volumetric flow rate of 14 SLPM (0.5 SCFM).

Each dehydrator consists of an electrically driven air compressor, a membrane dryer assembly, an automatic transmission line pressure sensing system, and alarm outputs housed in a rigid metal chassis. It is designed to mount directly to a rack, on a wall shelf, or as a free-standing unit. The front panel features a control interface with display for alarms and pressure. For easy serviceability, power connections, alarm output connections, and all

filter elements are accessible from the outside or through easy-to-access service panels.

The MT500B maintains transmission line pressures from 14-34 kPa (2.0 to 5.0 psig). It is intended for standard microwave antenna applications and any other transmission line pressurization requirement that supports a medium pressure limit for a typical land based communications systems.

1.3 Theory of operation

The MT500B series of DryLine® Dehydrators, while similar in moisture removal technology, **operates differently than some of the DryLine® series of dehydrators.** In order to maintain a positive constant level of pressure to medium air volume systems, and to maintain an acceptable dryness level in the product air stream, a downstream pressure sensor is utilized for controlling the operation of the unit. This feedback controlled sensor prompts the unit to engage at 14 kPa (2.0 psig) and shut down at 34 kPa (5.0 psig). In addition to monitoring the downstream flow, the system is also set up to utilize the downstream flow to provide the dry air for the feedback loop. The feedback loop is necessary to maintain the dryness of the membrane cartridge and will consume a small percentage of the air supplied by the dehydrator.

During normal operation, the bleed air in the feedback loop will cause the pressure to slowly drop in the downstream air flow, and the MT500B compressor will cycle automatically. These cycles will take place regardless of the system volume or condition of the transmission line the dehydrator is connected to. The rate of these cycles, however, will vary.

When connected to a normal system, the dehydrator's duty cycle should not exceed 10% and will maintain the system pressure between 14 kPa (2.0 psig) and 34 kPa (5.0 psig). If the duty cycle significantly exceeds 10%, check the system for leaks. **When open to atmosphere, the dehydrator will run continuously and provide approximately 14 SLPM (0.5 SCFM).**

The display will also reflect a pressure between 0 and 34 kPa (5.0 psig) while the output flow is between 0 and 14 SLPM (0.5 SCFM). The pressure sensor measures pressure beyond the flow control orifice and will show the actual pressure in the transmission lines (or to the distribution manifold).

1.4 Alarms

The MT500B offers Low Pressure, and Excess Run alarms as a standard feature. In addition, a summary alarm connection is provided on all units. Additional alarms are available in the discrete alarm version. These include High Humidity and Power Fail alarms. All four alarms, plus the summary alarm, have discrete connection contacts. Alarm conditions are indicated on the display. Form C dry contact is a physical contact (in this case a relay) that is single pole double throw (SPDT) with both Normally Open (NO) and Normally Closed (NC) contacts and a single common contact.

The external alarm monitoring system (supplied by others) is connected to the terminal strip located on the rear of the cabinet. A small slotted screwdriver is necessary to make the connections.

The connections to the alarm strip are as follows; refer to Figure 1 for correct locations and colors of the wires on the terminal strip.

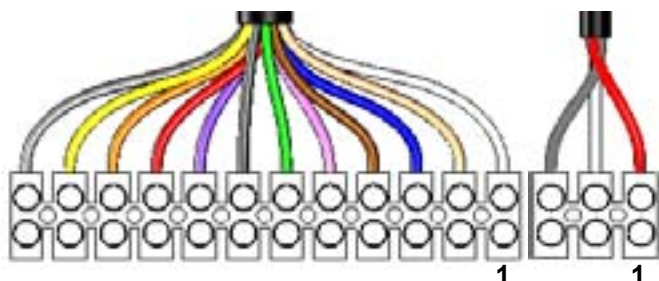

Figure 1 - Discrete Alarm Terminal Strip with Summary Alarm

DISCRETE WIRE FUNCTION REFERENCE		
WIRE TERMINAL	COLOR	ALARM FUNCTION
1	WHITE	EXCESS RUN NO
2	TAN	EXCESS RUN COM
3	BLUE	EXCESS RUN NC
4	BROWN	HIGH HUMIDITY NO
5	PINK	HIGH HUMIDITY COM
6	GREEN	HIGH HUMIDITY NC
7	BLACK	POWER FAIL NO
8	VIOLET	POWER FAIL COM
9	RED	POWER FAIL NC
10	ORANGE	LOW PRESSURE NO
11	YELLOW	LOW PRESSURE COM
12	GRAY	LOW PRESSURE NC



WIRE FUNCTION REFERENCE		
WIRE TERMINAL	COLOR	ALARM FUNCTION
3	BLACK	SUMMARY NC
2	WHITE	SUMMARY COM
1	RED	SUMMARY NO

Figure 2 - Summary Alarm Terminal Strip

Alarm Definitions:

- Summary:** Activates when the Excess Run, and/or Low Pressure alarms are triggered. It will also report High Humidity if unit is equipped with full alarms. The summary alarm does not report Power Fail.
- Power Fail:** Activates when power is removed from the dehydrator. This includes turning the power off at the switch.
- High Humidity:** Activates when system or dehydrator output humidity rise above 7.5% RH is equivalent to -16°C dew point at standard room temperature. At initial installation, this alarm will continue to alarm until the system has been properly purged.
- Excess Run:** Factory strapped run time set in accordance with the normal run time for the dehydrator application. Selectable times are 1, 10, 30, 120 and 240 minutes, with the 10 minute selection used on the MT500B as the default setting.
- Low Pressure:** If system pressure falls below the low-pressure trigger point (7 kPa (1.0 psig) on the MT500B), the low-pressure alarm sensor will activate an alarm contact. This alarm is an indication of a significant system leak or a dehydrator failure.

Note:

All of the alarms clear and reset automatically, but can be manually reset in the display menus. However, if the alarm condition still exists, the alarm will return immediately after being reset.

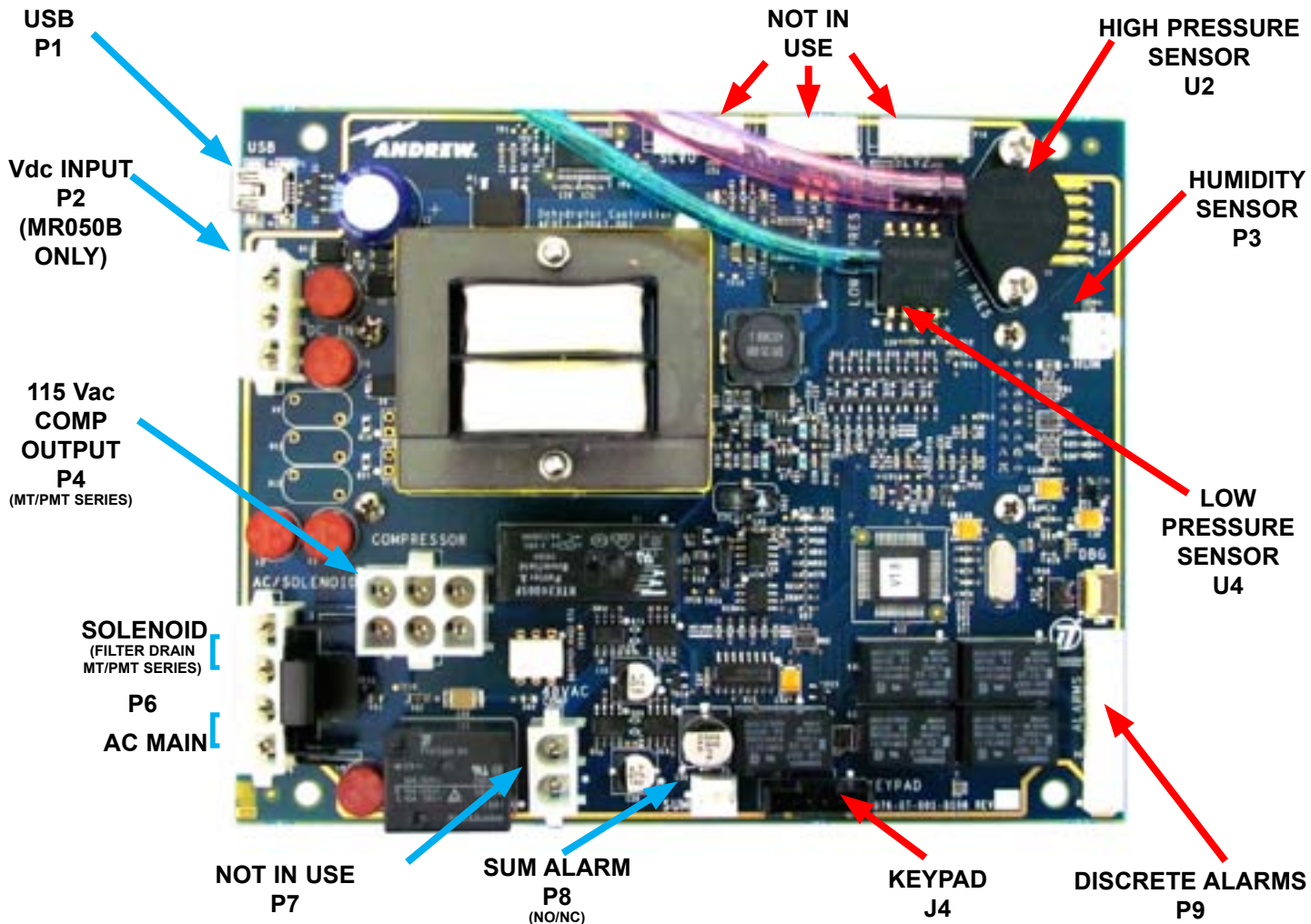

Figure 3 - Pin and Jumpers Location

1.5 Specifications MT500B Dehydrator

Output Pressure Constant, kPa (psig)	0-35 (2.0-5.0)	Dimensions	Height, cm (in)	43.2 (17)
Output capacity	14.0 SLPM (0.5 SCFM) (total, approx.)		Width, cm (in)	26.4 (10.4)
			Depth, cm (in)	32 (12.6)
Output Dew Point,	-45° C (-50°F) or better	Net weight, kg (lb)		16.55 (36 1/2)
Operating Temperature Range	-10° to +50°C (+14° to +122°F)	Alarms		
Electrical Input		Power Fail Alarm	loss of input power	
-81015 and -81315	115 ±10% Vac, 60 Hz	High Humidity Alarm Set Point	7.5% RH is equivalent to -16°C dew point at standard room temperature	
-81026 and -81326	230 ±10% Vac, 50/60 Hz	Excess Run Alarm	10 minutes, factory set	
	24 or 48 Vdc with Inverter	Low Pressure Alarm, kPa (psig)	6.9 (1.0)	
Output Connector	3/8" polytube, compression			

Section 2 Installation

2.1 Unpacking and Inspection

Open carton.



Remove the top piece of foam packaging. Carefully remove the installation accessories, manual and dehydrator. Check the dehydrator for shipping damage such as dents or loose parts.

2.1.1 Installation Kit Items

Polyethylene Tubing Kit,	(25 FT)
PTFE Tape, 1/4 Wide	(1 Roll)
Ball Valve, 3/8 Poly To 3/8 Poly	(1)
Male Conn, 3/8" Poly To 1/8 NPT Male	(2)
Street Elbow Fitting, 1/8 NPT (M-F)	(2)
Power Cord, w/Nema 515p Plug (North America)	(1)
Power Cord, IEC, Harm, (Stripped Leads)	(1)
Screw Pan Head, 10-32 X .50, w/Plastic Washer	(8)

2.2 Controls and Displays

Default password is 1111

Familiarize yourself with the controls and displays prior to installing or testing the dehydrator.



Keypad Controls:



Advances display (scrolls ahead) to the next display or program mode with out changing the values in the microprocessor memory.



Enters into the microprocessor memory the values displayed in the window and advances display (scrolls ahead) to the next program or display mode.



Numerically increase displayed settings in display window. When depressed longer than 1/2 second scrolling will occur at a faster rate.



Numerically decrease displayed settings in display window. When depressed longer than 1/2 second scrolling will occur at a faster rate.



Used to allow the user quick access to the system event log.

2.2.1 Event Log Codes

EV= 0	Event = Power Up
EV= 1	Event = High Humidity Alarm
EV= 2	Event = Excessive Run Time Alarm
EV= 3	Event = Low Pressure Alarm
EV= 4	Event = High Pressure Alarm
EV= 5	Event = Compressor Fault
EV= 6	Event = Log Cleared
EV= 7	Event = Powering Down
EV= 8	Event = Compressor Lifetime Eeprom Fail

2.3 Installing the Dehydrator

2.3.1 19" Rack Mounting or set on optional shelf

2.4 Power Connections

Confirm your dehydrator electrical input matches the available power.

Ensure an electrical safety ground is installed on the ground stud located adjacent to the power input connector. (It is intended to be customer installed in the field to your halo grounding system.)

MT500B-81015 and MT500B-81315
 115 ±10% Vac, 60 Hz
 24 or 48 Vdc with Inverter

MT500B-81026 and MT500B-81326
 230 ±10% Vac, 50/60 Hz

2.4.1 AC Power

AC units should be connected into a standard 15 Amp power receptacle of the proper voltage. Make sure the power circuit is properly grounded.

Two power cords are supplied, one 115 Vac American and one 230 Vac International (with striped leads).



CAUTION:
 Proper electrical connection is required. It is suggested a licensed electrician be contracted to connect the AC wiring to the unit, if it is connected directly to the mains. Failure to properly connect the power wires could result in a dangerous electrical shock hazard.

CAUTION:
 This unit is designed for connection to a single phase power source. Connection to a 3 phase power source will cause significant damage to internal components.

2.4.2 DC Power

The MT500B can operate on 24 Vdc or 48 Vdc with the addition of an optional inverter.

For details see section 7.

2.4.3 Test the Dehydrator

Turn the dehydrator **ON** there is about a 4 second delay and check the output port at the rear of the unit to make sure air is flowing.

2.5 Connecting the Alarm Outputs

To connect the alarms, locate the terminal block (TB-1) on the rear of the unit.

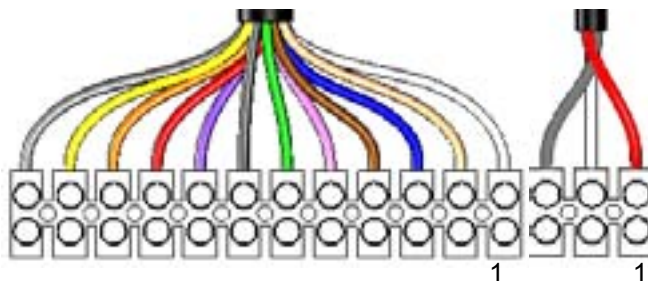

Place alarm connection wires in proper terminals and tighten the screw on the terminal block.

(See Section 1.4 for alarm locations)

The relay contacts are rated at 2 A (non-inductive), 30 Vdc.

2.6 Connecting Dehydrator to the Transmission Line

CAUTION:
 Check the antenna and transmission line system pressure rating before connecting the dehydrator to the system.

Using supplied PTFE tape screw one of the included 3/8" compression fittings into the output bulkhead. There is an elbow and a straight compression fitting included with the unit.

Insert one end of the 3/8" poly tube feed line tubing into the compression fitting on the dehydrator output port. Tighten securely with a 9/16" wrench. Be careful not to over tighten. Connect the other end of the poly tube to the transmission line.

Note: If the transmission lines have not been purged, continue with section 2.7. Otherwise proceed to section 3.

2.7 Purging the Transmission Line

Air in the transmission line system must be replaced with dry air to ensure satisfactory operation of the transmitted signal.

1. Determine the total system volume.
2. Divide the system volume by the flow rate of the dehydrator 14 SLPM (0.50 SCFM) to determine the number of hours needed for one purge cycle.
3. Open the far end of the transmission line.
4. Operate the dehydrator for no less than three purge cycles.

If it is not possible to open the far end of the transmission line, follow these steps:

1. Connect the dehydrator to the transmission line and pressurize the system. The system pressure should reach 34 kPa (5.0 psig).
2. Wait 15 minutes while the air absorbs moisture in the system, then disconnect the dehydrator from the transmission line and allow the air to vent.
3. Repeat steps 1 and 2 twelve times to purge the system.

Section 3 Maintenance

3.0 Maintenance

The MT500B Dehydrator requires relatively little maintenance to ensure satisfactory operation over long periods of time. This section outlines the recommended annual preventive maintenance for the unit and the suggested overhaul for every 6000 hours of compressor operation.

3.1 Preventive Maintenance

The annual maintenance of a MT500B consists of a preventative maintenance inspection of the dehydrator and replacement of the foam air intake filter. These tasks can easily be performed in the field with the unit connected to the transmission line system and with only the front and top access panel opened for maintenance. In addition to the annual inspection, a complete overhaul is recommended every 6000 hours or sooner if local conditions warrant.

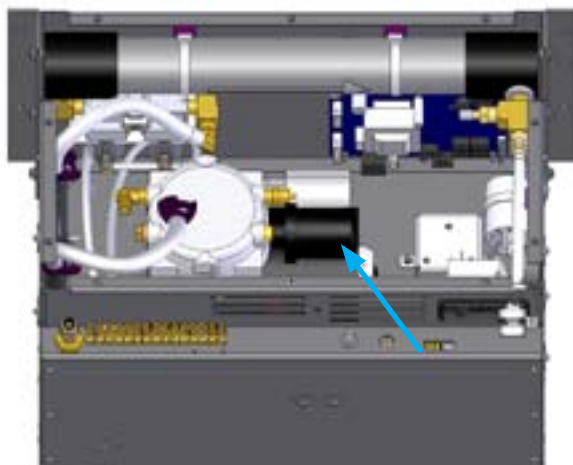

3.2 Dehydrator Filter Element Replacement

Replace the air intake filter

The air intake filter protects the compressor from contamination and dust. Periodic replacement extends the life of the compressor. To gain access to the element, push in on the cover and rotate the house approximately 1/4 turn CCW. The filter is made of a fibrous material. It should be replaced once a year (or more frequently, if the operating environment is very dusty.)



CAUTION:
Do not apply oil or other chemicals to the filter element.

Make sure the element is seated completely in the housing and then replace the cover. Discard the old element.

3.3 Annual Inspection

Warning:
To prevent injury or death from electrical shock, disconnect all electrical power to the dehydrator unit and tag out-of-service prior to performing any maintenance.

Inspection includes checking for loose or damaged hoses, fittings and electrical connections. Open the top cover and front door and verify that there is no water build-up in the two filter bowls located inside the front cover of the dehydrator. There may be some droplets of water in the filter bowls (the lower portion of each bowl), but there should be only a small amount of liquid in either bowl

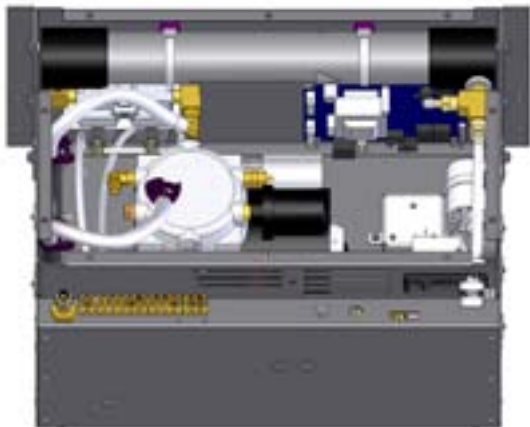

If there is excessive water, refer to the troubleshooting section 4. Replacement of the filter elements in the water filter and coalescing filter is covered in the overhaul section of this manual.

3.3.1 Check the electrical connections.

Check the screw at the power input connector lock to ensure that the AC power cord is securely terminated. Check the screw-in alarm terminals to ensure that all wire connections are tight.

A loose or damaged connection may result in erratic operation and unnecessary downtime. Refer to the troubleshooting section 4 if an electrical problem is encountered.

3.3.2 Check the ground wire.

Check that an electrical safety ground is installed on the stud on the rear of the dehydrator. This connection point is adjacent to the power input connector. (It is intended to be customer installed to the halo grounding system.)

3.3.3 Check the hour meter

Check the hour meter on the front panel to determine the duty cycle of the dehydrator.

If the dehydrator has been running for more than 10% of its installed time, check the systems for leaks. Also check the time on the meter to determine if it is time to perform the 6000-hour overhaul.



3.4 Parts Replacement and Dehydrator Overhaul

CommScope MT500B Series DryLine® Dehydrator are designed to give many years of trouble-free service and require very minimal maintenance. The dehydrator contains, as a standard feature, an hour meter that records compressor run hours. To ensure continuous and reliable operation, the dehydrator must be overhauled every 6000 hours of compressor operation. The kits, shown in Section 5, contain all of the necessary parts to perform this overhaul. The dehydrator overhaul kit includes parts to overhaul the compressor and critical components in the dehydrator that often become worn over time.

3.4.1 In Case Of Difficulty

If the dehydrator is not operating, refer to Section 2 on Installation and Section 4 on troubleshooting the unit.

3.4.2 Tools

The following tools are used in the maintenance and overhaul procedures.

- Adjustable open-end wrench
- Allen wrench 5/32
- #2 Phillips screwdrivers
- Small flat-blade screw-driver

3.4.3 Overhaul Procedure

When the MT500B compressor run time reaches 6000 hours (or a multiple of 6000 hours) it is time to replace certain items in the compressor and the air path of the dehydrator. These include the piston cups, piston seals and head gaskets of the compressor, the filter elements in the water and coalescing filters, and the tube section connecting the compressor output to the heat exchanger.

In addition, if the unit gives the low pressure alarm, the compressor may be in need of an overhaul. This does not always coincide with the 6000 hour time frame. If the low pressure alarm is triggered, check the system for leaks. If no leaks are detected, the compressor will need to be overhauled.

3.4.4 Unit Shutdown and Removal

In order to perform an overhaul on the MT500B, the unit must be turned off and removed from service. As this is being done, the low pressure alarm may activate through a reporting alarm system. Personnel monitoring such an alarm should be notified in advance so that they are aware of the fact that service is being performed. It is also necessary to disconnect the dehydrator dry air output from the waveguide system during the overhaul.

3.4.5 Unplug the unit from the power supply.

Follow the instructions included in the compressor overhaul kit. When the overhaul is complete, reinstall. Complete overhaul can be done without removing the compressor from the chassis. The compressor head, air filter, output port and relief valve can all be removed through top panel. When the overhaul is complete, reinstall.

3.5 Service Restoration RECOMMENDATION:

If the dehydrator overhaul process has taken more than a few hours, it is recommended that the unit be run for one hour into the room, to purge the membrane dryer of any acquired moisture, before reconnecting to the transmission line system.

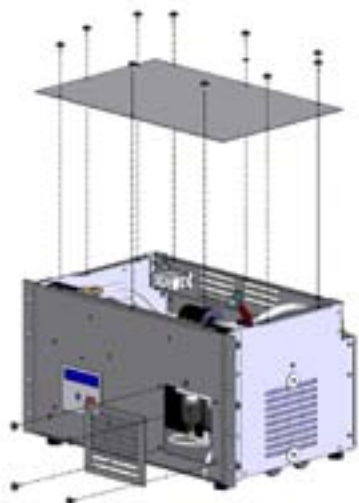

Section 4 Troubleshooting

If you experience difficulty with your dehydrator, use the troubleshooting procedures described below.

Caution: Electrical troubleshooting requires access to potentially dangerous voltages and should only be performed by a licensed electrician

Problem/Condition	Solution
Dehydrator display does not light, unit does not run.	If the display light falls to light, make sure the unit is plugged in and power outlet is operating.
	If you still have no light, unplug the unit, remove the unit cover and check for loose connections. Refer to the wiring diagram for proper connections. (Figure 4 or 5)
	Check to ensure that proper AC voltage is being supplied to the input.
Low-pressure alarm activated.	Turn shut-off valve to the off position and observe pressure gauge. The pressure gauge line should read approximately 34 kPa (5.0 psig) and the alarm should clear. If alarm does not clear, remove cover and verify tubing and wiring connections are secure.
	If the pressure does not stay constant after shutting off the valve, apply leak detector to isolate the leak in the dehydrator (exercise care when applying solution not to wet wiring or electronics).
	With dehydrator isolated from transmission line, observe pressure in transmission line. If pressure drops, use a leak detector solution to locate leaks in the transmission line. Repair leaks if possible.
	If the problem persists contact CommScope Customer Service. (Section 6)
Compressor does not turn.	Check the display on the controller. Toggle the ON/OFF switch (attached to power connection).
	Check input voltage per wiring diagram (Figure 4 or 5)
	If the problem persists contact CommScope Customer Service (Section 6)
Filter bowls show excessive water.	Ensure that the drain line tubing (exiting the bottom of the drain solenoid) is not clogged. When the compressor cycles off, air and moisture should flow out of the drain line (into drain pan).
	If solenoid does not vent, verify proper voltage is present when compressor is running and absent when compressor is off.
	If proper voltage is present and solenoid does not shift, replace solenoid. (See Section 5 for replacement parts.)

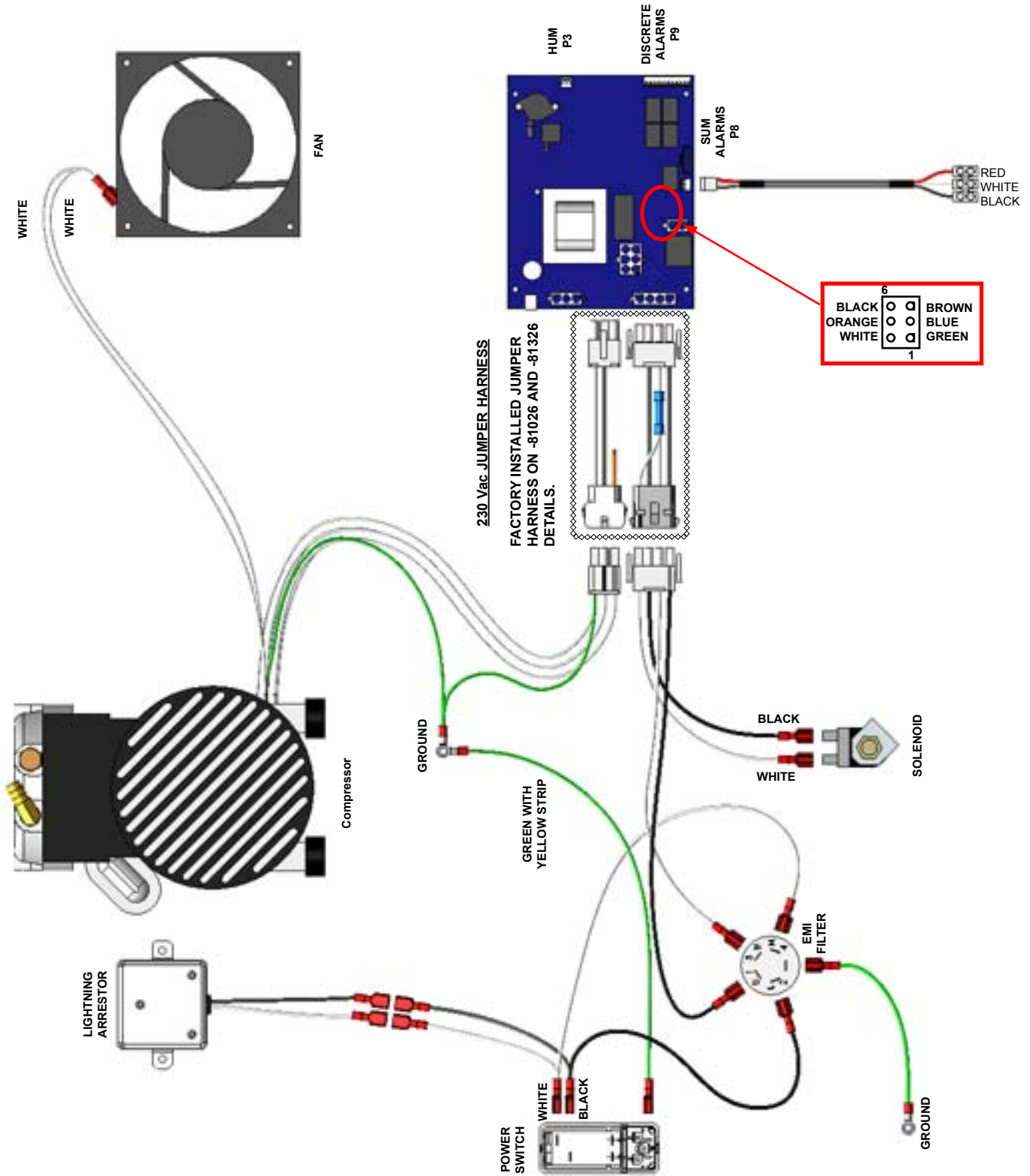

Figure 4 - MT500B-81015 Electrical with Summary Alarm

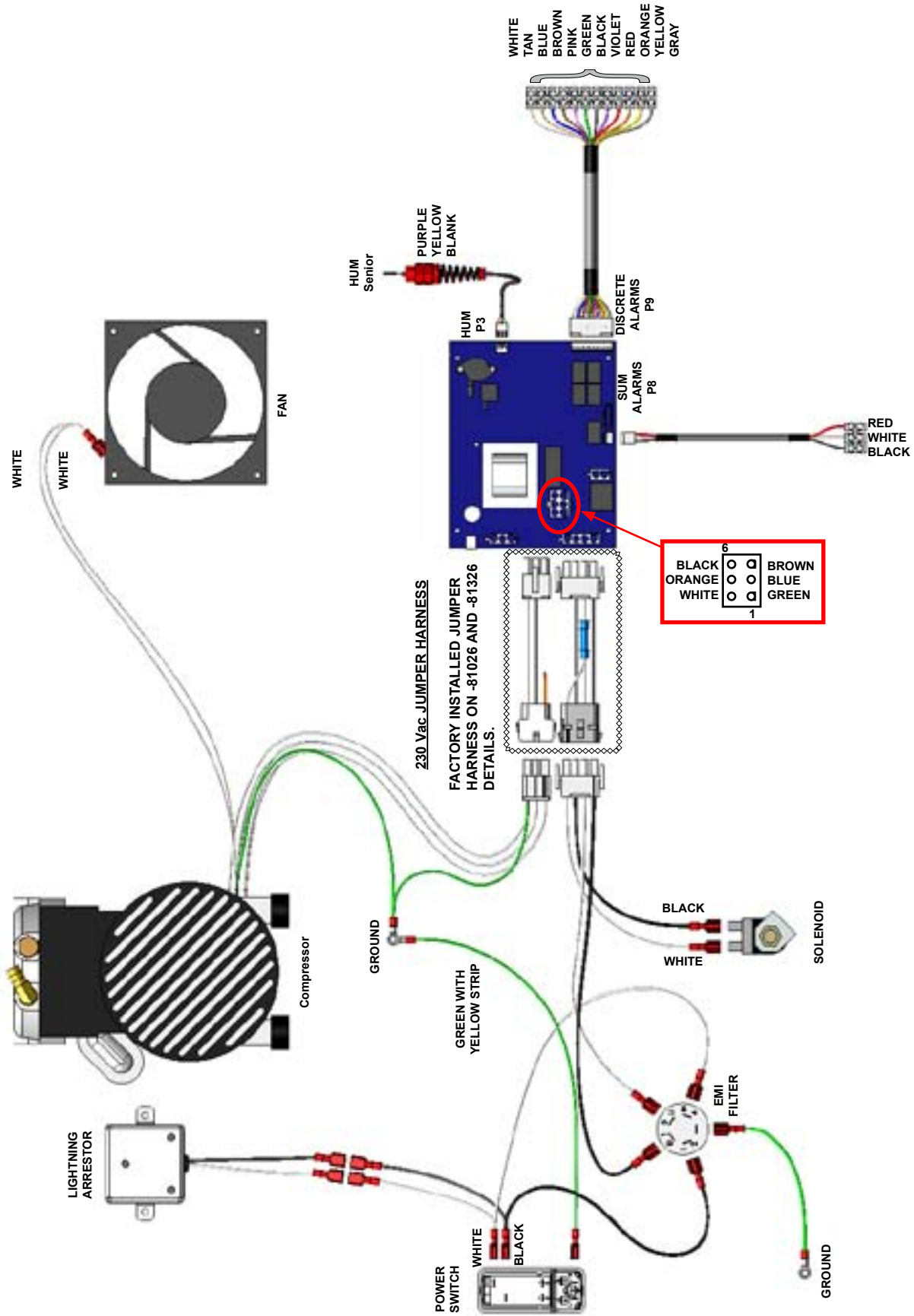

Figure 5 - MT500B-81315 Electrical with Discrete Alarm

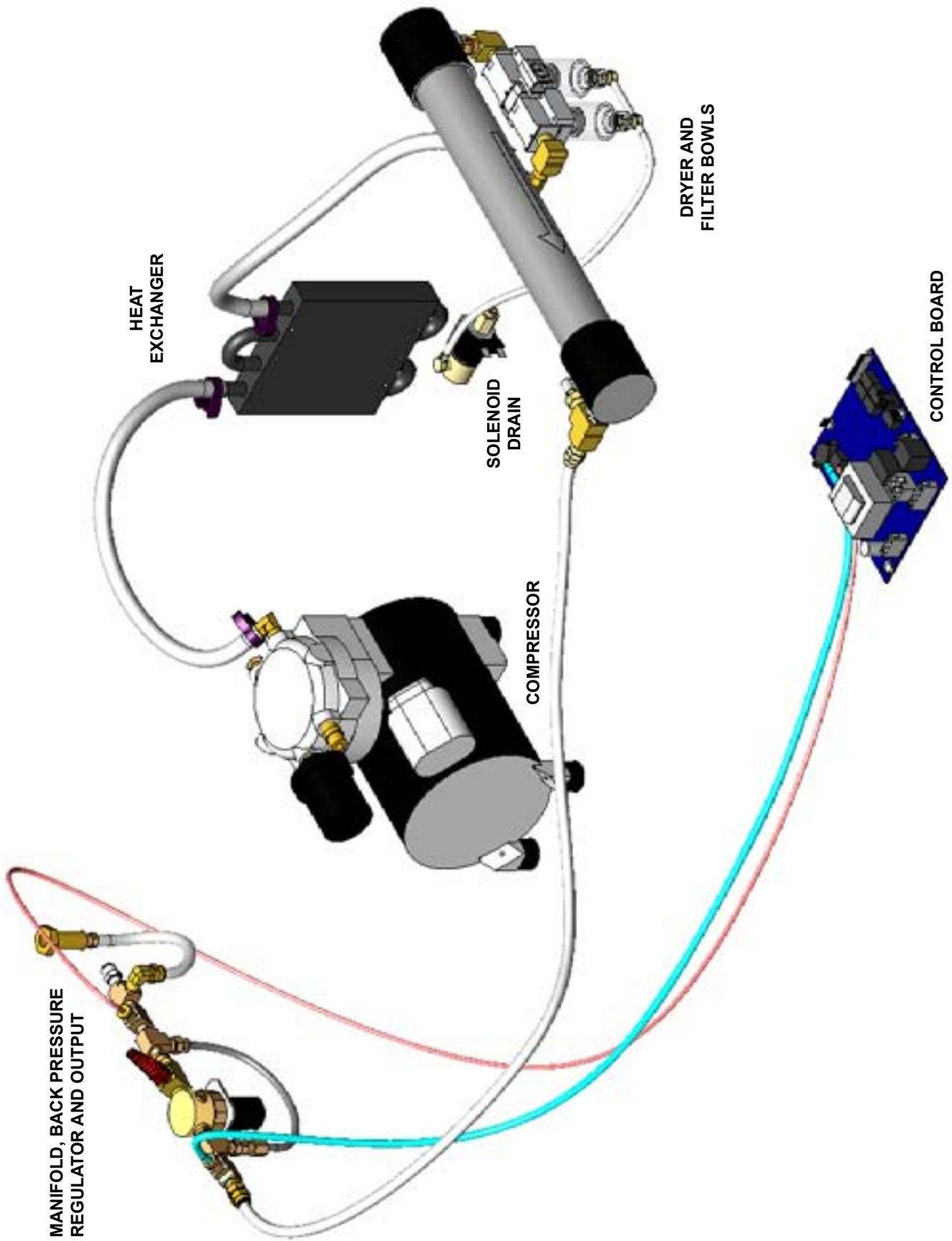

Figure 6 - MT500B Pneumatic Diagram

**Section 5
Replacement Parts**

Go to [commscope.com](http://www.commscope.com) eCatalog for the most current parts available for your dehydrator.
<http://www.commscope.com/Product-Catalog/#market-wireless>



Overhaul Kit MT500B-KIT-OVRHL



Filter Element Replacement Kit MT500B-KIT-ELMNT

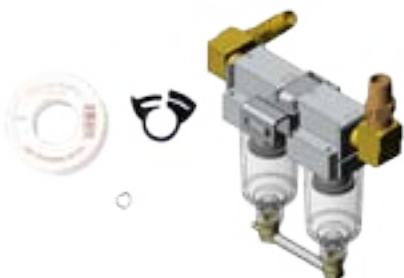

Filter Bowl Assemble Replacement Kit MT500B-KIT-FLTRS



Filter Bowl Assemble and Dryer Tube Replacement Kit MT500B-KIT-DRYER



Solenoid Replacement Kit MT500B-KIT-SOLND

**Section 6
Customer Service**

6.0 Introduction

CommScope provides in-warranty and out-of-warranty repairs as well as dehydrator and compressor overhauls from several Repair Centers. Coordination of these services is provided through the nearest Sales Office or Customer Service Center. The Center is also prepared to help you with the following:

- Technical Assistance
- Troubleshooting
- Repairs
- Loaner Units
- Spare Parts
- Installation Materials
- System Accessories

6.1 In Case of Trouble

The first step you should take if trouble develops using a dehydrator is to read the operators manual and follow the trouble isolating procedures given in it.

If the steps in the manual do not identify and remedy the problem, then contact an CommScope Customer Service Center for 24-hour telephone assistance. Record the Model Number (e.g. MT500B) and Serial Number from the product label, as you will be asked for these when you call. Two main locations are currently available to help:

From North America
Telephone: 1-800-255-1479
Fax (U.S.A.): 1-800-349-5444

International
Telephone: +1-779-435-6500
Fax Number: +1-779-435-8579

Web Access
Internet: www.commscope.com
email: #prc@commscope.com

6.2 Initial Steps by CommScope

When your call or fax communication is received, the CommScope staff will work with you to pinpoint the possible cause of trouble. If the pressurization equipment is suspect, they will:

- ask for your unit Model Number and Serial Number
- check the warranty status of the unit
- advise the availability of a loaner unit
- provide an estimate of the cost for inspection and repairs, if the unit is out-of-warranty
- fax a Return Material Authorization Sheet to you.

6.3 Repair Center Process

A method of Payment must be provided prior to issuing of RMA regardless of warranty status.

IN-WARRANTY REPAIR: Most CommScope pressurization products carry a warranty of one to three years, depending upon model number. Warranty details are available on our web page. If your unit falls within its warranty period, inspection and repairs will be performed at no charge and the unit will be promptly returned to you. If a warranty unit is deemed no problem found an inspection fee and freight will be charged to the customer.

OUT-OF-WARRANTY REPAIR: We will inform you with the cost of repair and obtain your approval to proceed with repairs or, if you elect not to have the unit repaired, your instructions on disposition of your unit. When repairs are complete, we will return your unit and invoice you for the inspection charge, materials used for the repair and labor applied to complete the repair. If you elected not to repair the unit, we will invoice you for the inspection and freight charge if unit is to be returned.

LOANER UNITS: Loaner units are available from the repair center to maintain your system while repairs are being performed. If you feel you need a loaner, please contact us at one of the numbers listed under contact numbers. A P.O. for the full value of the unit must be issued prior to shipment. Also contact us when the loaner is ready to be returned so that we

can issue a NEW RMA number to identify your return and create the appropriate credit to your account. Damages to loaner will be deducted from the P.O.

PACKING INSTRUCTIONS: Pack your unit securely for shipment to the Repair Center. If you received a loaner unit, we suggest you use the box and packing materials to return your unit. Otherwise we have factory packing materials available for a nominal fee. Enclose a completed copy of this form inside the box and clearly mark your Company Name and RMA: XXXXXXXX on outside of the box. Address the box to the following Ship-To Address:

CommScope Pressurization Service Center
RMA# XXXXXXXX
11312 S. PIPELINE RD.
EULESS, TX. 76040-6629

Please note, Units received with Biological/ animal contamination will be returned unrepared or scraped after notification and you will be invoiced for inspection and freight.

CONTACT NUMBERS: If you have any questions about the repair process or status of your unit, please contact us directly through one of the following methods – Telephone (below)

TEL: 817-864-4150
817-864-4155

FAX: 817-864-4179

6.4 RoHS Inquiries

For inquiries on RoHS please contact the following:

C/O CommScope Inc.
Corke Abbey, Bray Co.,
Dublin, Ireland
Attn: Legal Department

Section 7 DC Inverter Option

7.1 Introduction

The standard 115 Vac unit can be run on an inverter with the input of 24 or 48Vdc inverter. The inverters are available in either 24 or 48 Vdc. Due to the induction of a dc motor in the compressor pulling so many amps and the cost of a dc compressor we choose to power the units with an inverter to keep the cost down and reduce the induction load on your battery systems.

7.2 Installing the 24 Vdc to AC inverter

Remove the inverter from its packaging and install in desired location. The inverter can be placed on a flat surface or mounted to a wall via the flanges and slots on the bottom of the inverter.



Verify power switch is turned off on the inverter.

Connect the power cord from the dehydrator to the AC receptacle located on the left side of the inverter.



Connect the DC power to the lugs located on the right side of the inverter to the battery system. Ensure the polarity is correct. Improper connection can damage inverter and void warranty.



Turn inverter on. Only green LED's should be illuminated.

Turn on Dehydrator.

7.3 Installing the 48 Vdc to AC inverter

Remove the inverter from its packaging and install in desired location. The inverter can be placed on a flat surface or mounted to a wall via the flanges and slots on the bottom of the inverter.



Turn inverter on. Only green LED's should be illuminated.

Turn on Dehydrator.

Verify power switch is turned off on the inverter.

Connect the power cord from the dehydrator to the AC receptacle located on the left side of the inverter.



Connect the DC power to the lugs located on the right side of the inverter to the battery system. Ensure the polarity is correct. Improper connection can damage inverter and void warranty.