

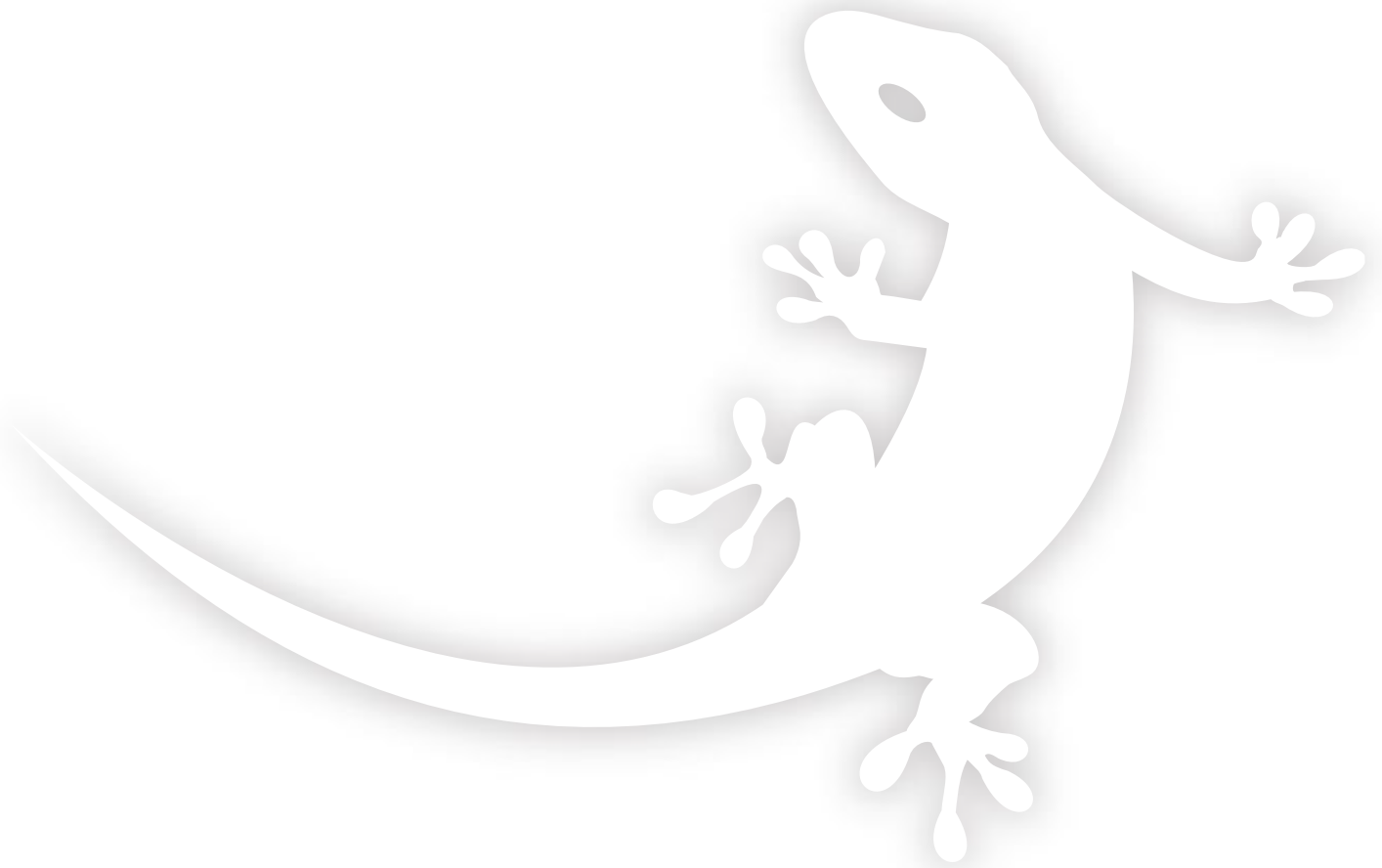

User Manual myGEKKO RIO modules

V 0.21





Latest Update: July 2012

All software-related descriptions refer to the V1279 software. An update is recommended for older versions of the system. Small deviations of the descriptions are possible and due to changes in the software.

All brands and logos are registered trademarks and are the property of the respective holders of the rights

Copyright

All rights reserved. No parts of this document may be reproduced or transmitted in any form by any means, electronic or mechanical, without the prior written authorization of its legal owner.

If this publication is made available on Ekon GmbH media, Ekon gives its consent to downloading and printing copies of the content provided in this file only for private use and not for redistribution. No part of this publication may be modified, altered or used for commercial purposes. Ekon GmbH is not liable for the damages which arise from the use of an illegal modified or altered publication.

CE All products correspond to the directly applicable EU regulations and guidelines.

Table of Contents

1. Introduction

1.1 General Information	4
1.2 Sub-Bus configuration	4

2. Technical specifications

2.1 Rio 29

2.1.1 General technical specifications	6
2.1.2 Digital inputs X4	7
2.1.3 Analog inputs X5, X6	8
2.1.4 Digital outputs X7	8
2.1.5 Analog outputs X5, X6	9
2.1.6 Aux1 / RS-485 X3	9
2.1.7 MBus X3	9
2.1.8 Aux2 / RS-485 or RS-232 X3	9
2.1.9 Screw terminals	10
2.1.10 Spring clamp terminals	10
2.1.11 Installation specifications RIO 29	11
2.1.12 Functional description Dip switch RIO 29	12

2.2. Aux-8

2.2.1 General technical specifications	14
2.2.2 Digital PWM inputs X100	15
2.2.3 Analog outputs X101	15
2.2.4 Connection example	16
2.2.5 Installation specifications	16
2.2.6 Spring clamp terminals	17

2.3. Rio 16

2.3.1 General technical specifications	18
2.3.2 Digital inputs X4	19
2.3.3 Digital outputs X5, X6, X7	20
2.3.4 Screw terminals	20
2.3.5 Spring clamp terminals	21
2.3.6 Installation specifications RIO 16	22
2.3.7 Functional description Dip switch RIO 16	23

2.4 Functional description LEDs	26
---------------------------------------	----

2.5 Buswiring	27
---------------------	----

2.6 Configurations example	28
----------------------------------	----

2.7 Schematic example	30
-----------------------------	----

3. Installation manual	32
------------------------------	----

4. Software activation at myGEKKO	33
---	----

1. Introduction



WARNING: Read all safety information and instructions before using the RIO modules in order to avoid injuries.

1.1 General Information

The basic function of the RIO-modules consists of data acquisition (digital and analogue inputs) and the triggering of digital and analogue outputs respectively. RIO-modules are controlled via a RS-485 connection. The devices themselves have no intelligence.

Solely, the operating status of the digital outputs can be determined in case of communication failure. The modules are built-in appliances and may be installed only by qualified personnel. The necessary covers must be in place (see section installation instruction).

1.2 Sub-Bus configuration

The maximum number of modules which can be connected to a RIO-29 bus coupler is 16 modules including bus coupler. Rio 16 or Rio 29 modules may be attached also in combination at will. The sub-bus modules may also be mounted on several distributors distinctively.

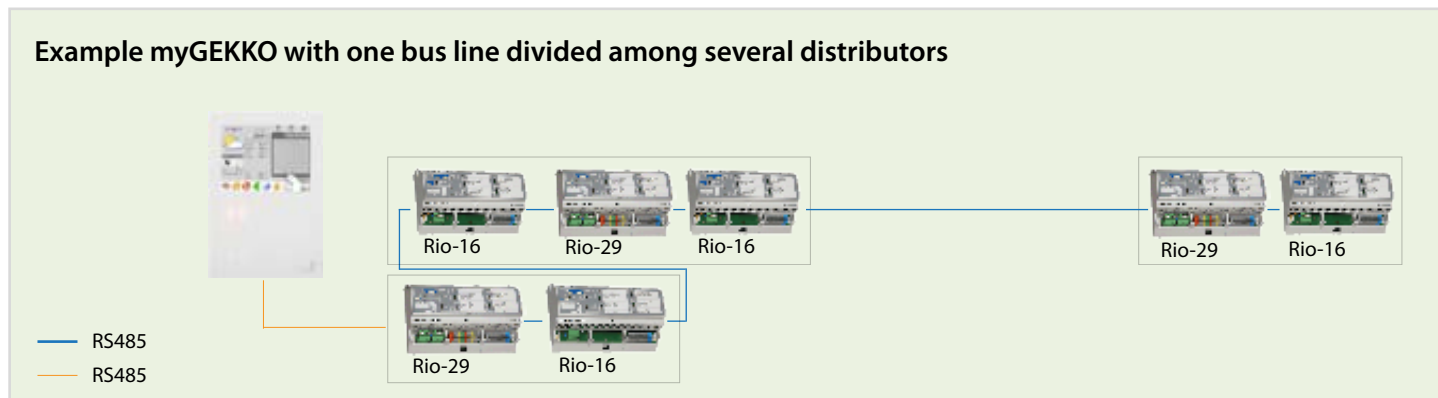

A maximum of 4 bus lines can be operated on a myGEKKO Touch (4 bus couplers RIO29).

Connections at the myGEKKO Touch

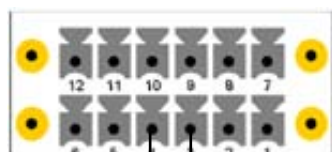

PIN	SIGNAL
2	RS485_GND
3	RS485_TX (RxTx+)
4	RS485_#TX (RxTx-)
7	V+ (10-32V)
8	V_GND

recommended cable type
Profibus L2FIP 1x2x0,65

Connections at the RIO29 bus coupler



X10
+24VDC
RxTx+
RxTx-
GND
Master
X1: Master
X2: Slave

to the Sub-Busmodules

Example maximum configuration with 4 Bus-lines

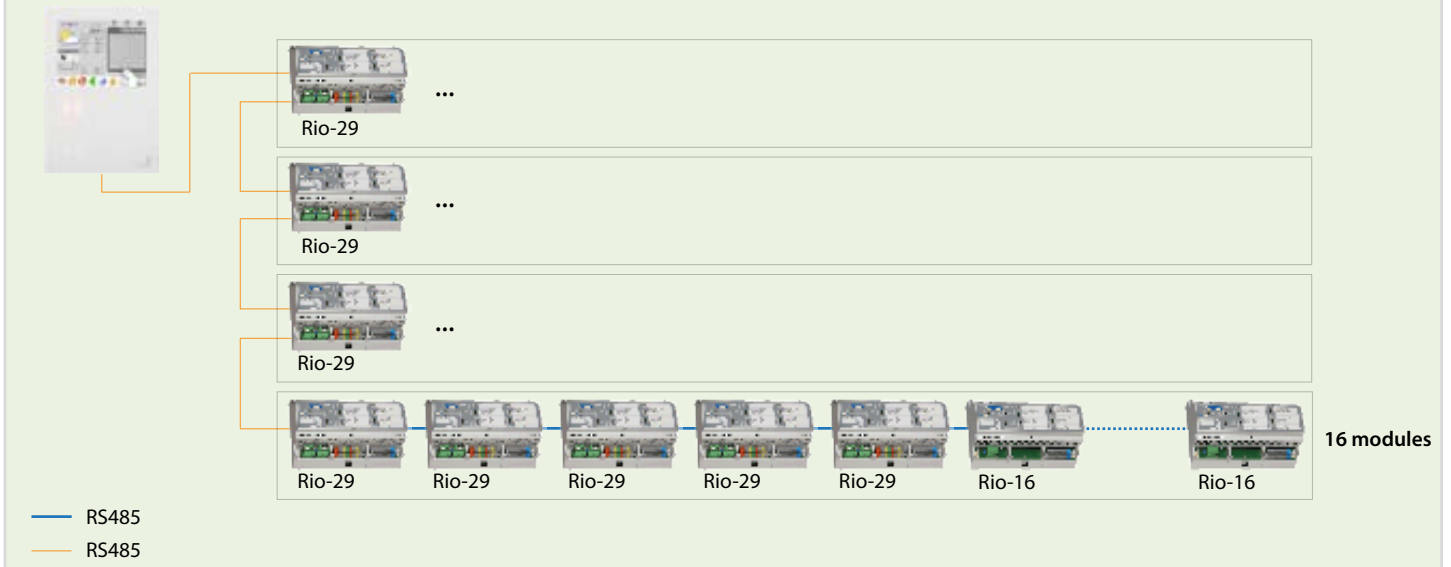

Note that the supply of the modules must be fused with 3A. If the power consumption exceeds 3A the modules have to be supplied separately.

The bus must be wired accordingly to X1 or X2 (sub-bus). Therefore, the following connections are required:

- +24VDC do not connect, but supply separately
- RxTx+ connect to previous module
- RxTx- connect to previous module
- GND connect to previous module

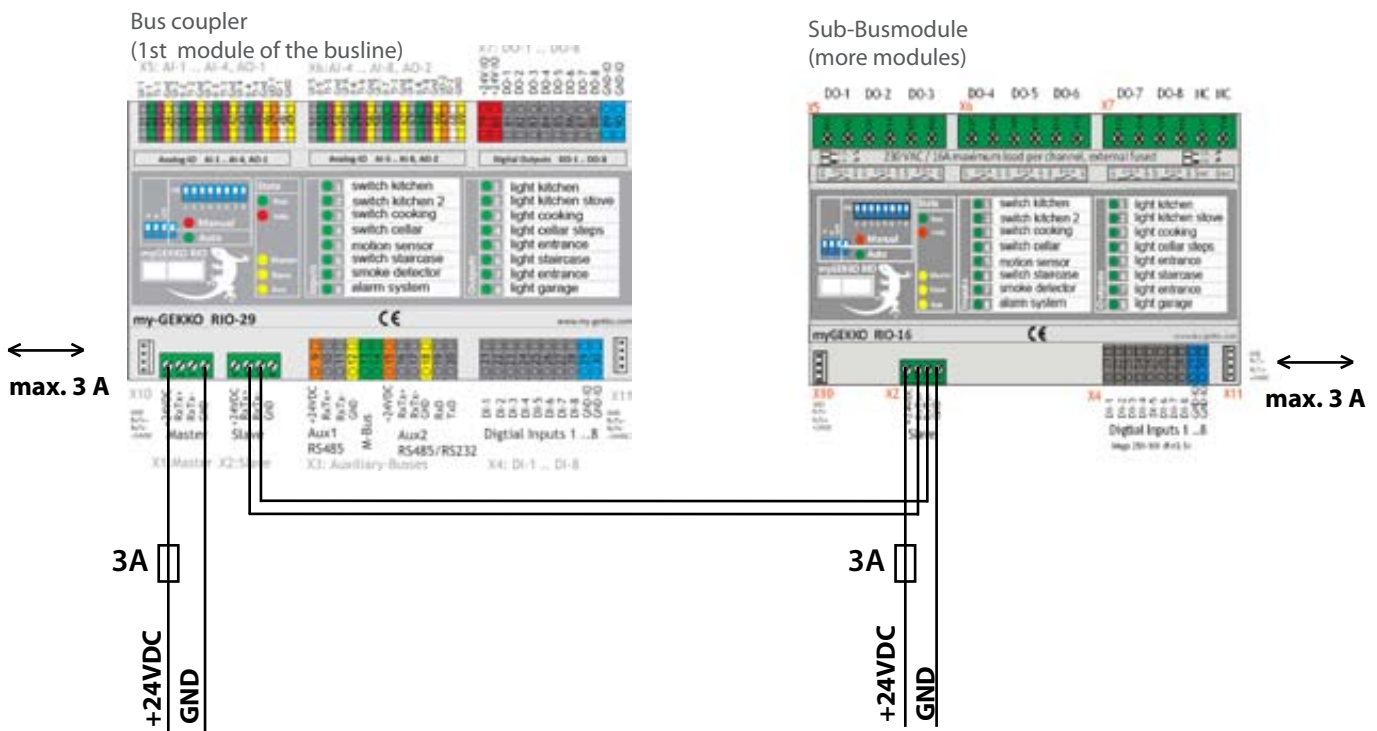

2. Technical specifications

2.1 RIO 29

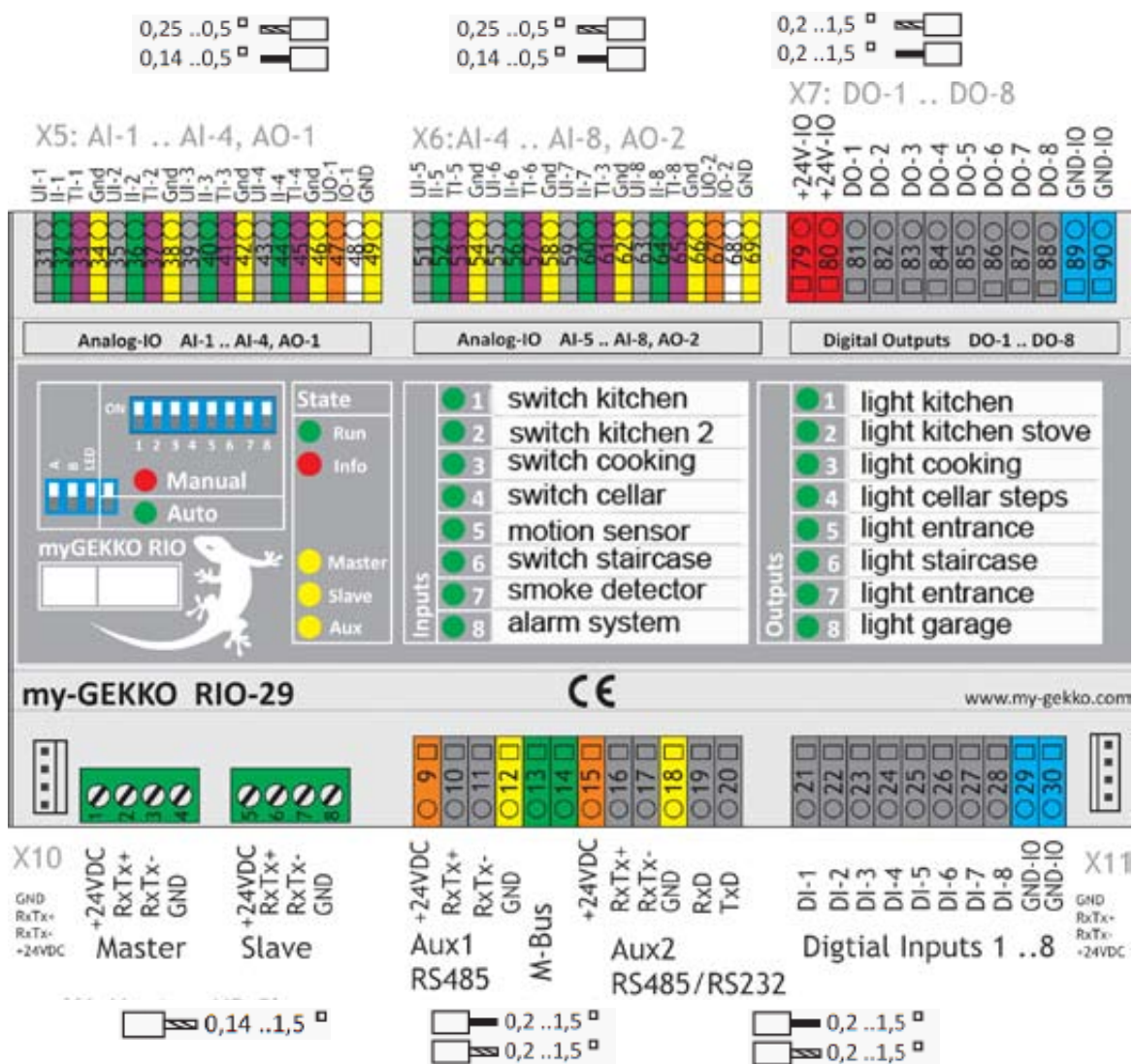

2.1.1 General technical specifications

Parameters	Value	Notes
Supply voltage	24VDC	-25% / +30%
Current consumption (internal)	max. 250mA	Typ. 100mA @ 24VDC
Temperature range during operation	- 20-50°C	
Storage temperature	- 40-85°C	
Operating time	100% ED	designed for continuous operation
Degree of protection	IP20	established via appropriate installation
Contamination level	2	
Protection class	II	
Principle of operation	Type 1	EN60730-1
Humidity	max. 75% r.H.	without condensation, during operation
Software class	Class A	
Dimensions	162mm x 110mm x 62mm	L x W x H
Weight	280g	
EMV	CE according to 2004/108/EG	
Rated surge voltage	0,5kV	
Output PV at 24 VDC	3 W	

2.1.2 Digital Inputs X4

There is a galvanic isolation to the modules of all inputs via opto-couplers.

Parameters	Value
Input type	Optically separated / opto-couplers
Isolation voltage	400V
Switch point On	>9VDC
Switch point Off	<5VDC
Maximum input voltage	24VDC +30%
Current consumption / Input @ 10V	2mA
Current consumption / Input @ 18V	3.8mA
Current consumption / Input @ 24V	5.5mA
Current consumption / Input @ 28V	6.2mA

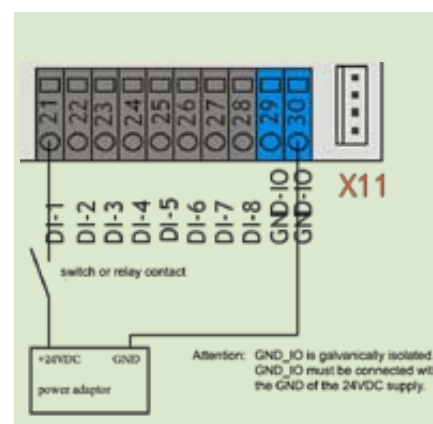

2.1.3 Analog inputs X5, X6

Parameters	Value
UI-x input range	0-10V voltage input 1mV (16 Bit ADC) 0 – 10'000
II-x input range	0-20mA current input 10uA (12 Bit ADC) 0 – 2'000 uA
TI-x input range	PT1000 0,1 Grad -500 – 2'500
TI-x temperature range	-50 – 250°C

0-20 mA

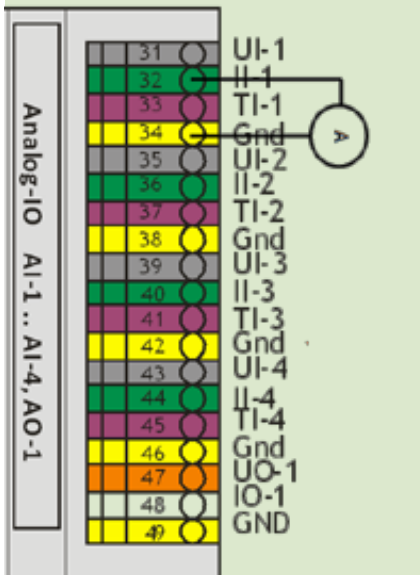

0-10 VDC

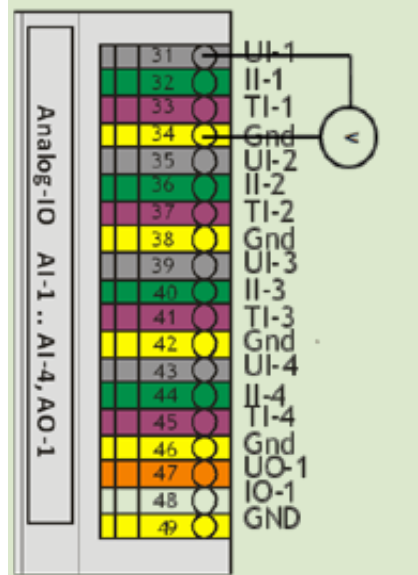

PT 1.000

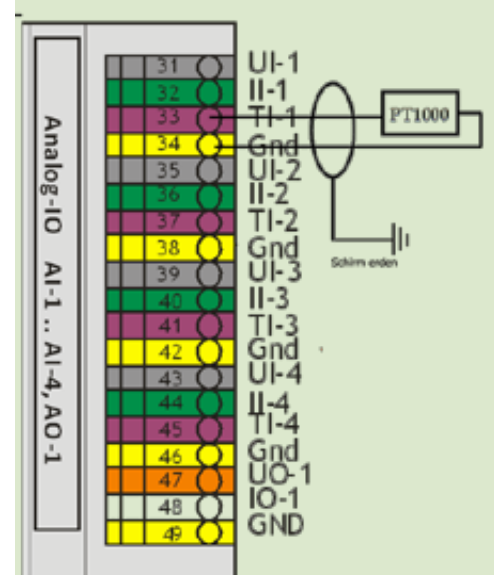

2.1.4 Digital Outputs X7

Parameters	Value/Notes
Type of output	PWM outputs / galv. non-insulated
Output current	0,5A / Short-circuit-proof
Power supply	Separate feeding (Supply must be fused externally with 5A) 24VDC -25% / +30%

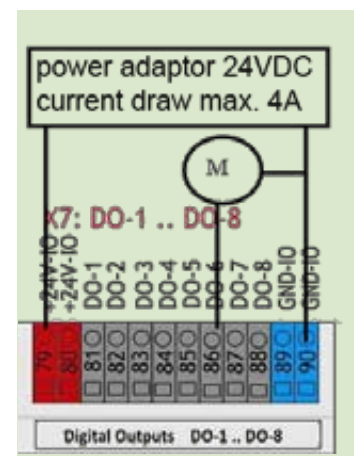

2.1.5 Analog outputs X5, X6

Parameters	Value	Notes
UO-X	Output 0-10V	12-bit resolution 0 – 4'096
UO-X	Max. load 10mA	short-circuit-proof
IO-X	Output 0-20mA	12-bit resolution coupled with UO-X
IO-X	Max. load 500 Ohm	pen-circuit-proof

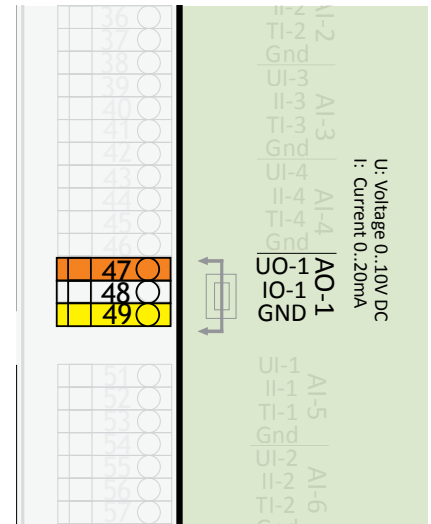

2.1.6 Aux1 / RS-485 X3

Parameters	Value
Interface type	RS-485
Baud rate	1200, 2400, 4800, 9600, 19'200 and 38'400 baud
Parity	adjustable

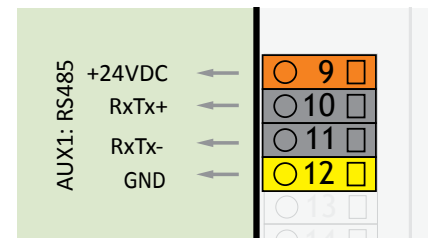

2.1.7 M-Bus X3

The module acts as bus master for a maximum of 3 M-bus slaves.

Parameters	Value/Notes
Interface type	M-Bus / +/-30VDC max. 60mA
Baud rate	1200, 2400, 4800, 9600, 19'200 and 38'400 baud
Parity	adjustable

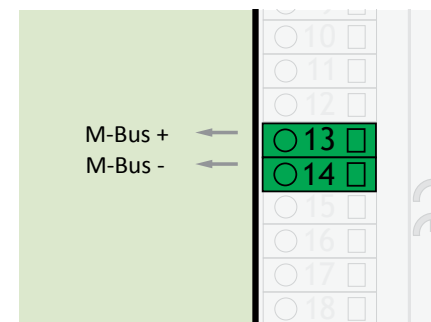

2.1.8 Aux2 / RS-485 oder RS-232 X3

Aux2 can either be operated as an RS-485 or RS-232 interface.

Parameters	Value
Interface type	RS-485 oder RS-232
Baud rate	1200, 2400, 4800, 9600, 19'200 and 38'400 baud
Parity	adjustable

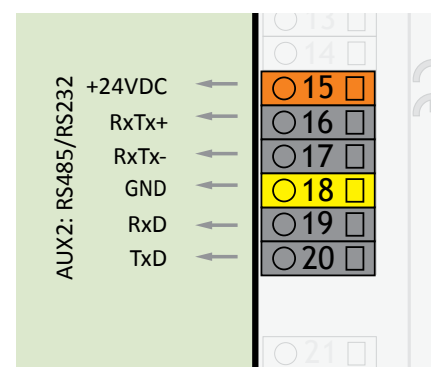

2.1.9 Screw terminals

X1, X2: type MCV1.5 / 4-St-3,81

Stripping length	7 mm
Connection data	
Conductor cross section rigid min	0,14 mm ²
Conductor cross section rigid max	1,5 mm ²
Conductor cross section flexible min	0,14 mm ²
Conductor cross section flexible max	1,5 mm ²
Conductor cross section flexible with ferrule without plastic sleeve min	0,25 mm ²
Conductor cross section flexible with ferrule without plastic sleeve max	1,5 mm ²
Conductor cross section flexible with ferrule and plastic sleeve min	0,25 mm ²
Conductor cross section flexible with ferrule and plastic sleeve max	0,5 mm ²
Conductor cross section AWG/kcmil min	28
Conductor cross section AWG/kcmil max	16
2 cables of the same cross section rigid min	0,08 mm ²
2 cables of the same cross section rigid max	0,5 mm ²
2 cables of the same cross section flexible min	0,08 mm ²
2 cables of the same cross section flexible max	0,75 mm ²
2 cables of the same cross section flexible with CES without plastic sleeve min	0,25 mm ²
2 cables of the same cross section flexible with CES without plastic sleeve max	0,34 mm ²
2 cables of the same cross section flexible with TWIN-CES with plastic sleeve min	0,5 mm ²
2 cables of the same cross section flexible with TWIN-CES with plastic sleeve max	0,5 mm ²

2.1.10 Spring clamp terminals

X3, X4, X7 type 250-210

Stripping length	8,5 mm
Connection data	
Conductor cross section rigid min	0,2 mm ²
Conductor cross section rigid max	1,5 mm ²
Conductor cross section flexible min	0,2 mm ²
Conductor cross section flexible max	1,5 mm ²
Conductor cross section flexible with ferrule without plastic sleeve min	0,25 mm ²
Conductor cross section flexible with ferrule without plastic sleeve max	1,0 mm ²
Conductor cross section flexible with ferrule and plastic sleeve min	0,25 mm ²
Conductor cross section flexible with ferrule and plastic sleeve max	1,0 mm ²
Conductor cross section AWG/kcmil min	20
Conductor cross section AWG/kcmil max	16

Stripping length	8,5 mm
Connection data	
Conductor cross section rigid min	0,14 mm ²
Conductor cross section rigid max	0,5 mm ²
Conductor cross section flexible min	0,2 mm ²
Conductor cross section flexible max	0,5 mm ²
Conductor cross section flexible with ferrule without plastic sleeve min	0,25 mm ²
Conductor cross section flexible with ferrule without plastic sleeve max	0,25 mm ²
Conductor cross section flexible with ferrule and plastic sleeve min	0,25 mm ²
Conductor cross section flexible with ferrule and plastic sleeve max	0,25 mm ²
Conductor cross section AWG/kcmil min	24
Conductor cross section AWG/kcmil max	20

2.1.11 Installation specifications RIO-29



Please note:

The ground (GND) of the power supply unit must be earthed.

The cable screens for the analogue inputs and outputs must be grounded on the module-side.

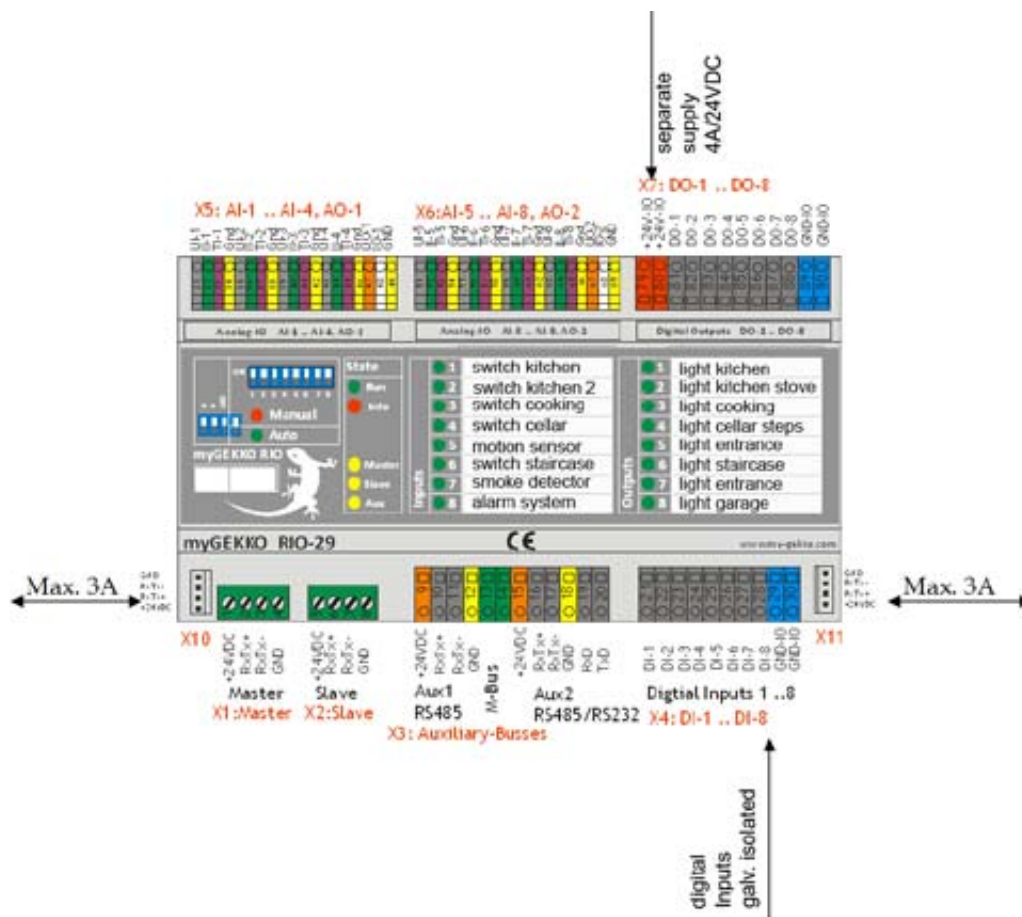

2.1.12 Functional description Dip switch RIO 29

The DIP-switches are activated when the corresponding switches are pushed upwards.

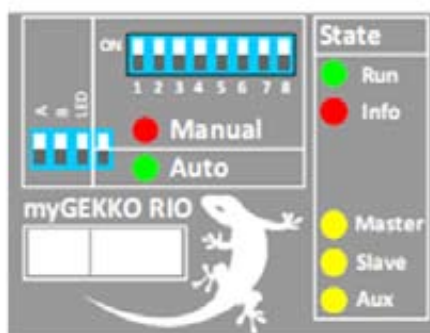

Parameters	Values
Manual operation switch 1..8	State of the corresponding output in manual mode or at bus timeout. ON = Output ON OFF = Output OFF
A	Behaviour of outputs in case of communication interruption. ON = Outputs retain current state (not remanent) OFF = Outputs attain the set manual mode.
B	Reserve (without functionality)
LED	State of the status LED on the module. ON = All LEDs are switched off OFF=All LEDs show the current module state
Manual	Manual operation ON = Switches all outputs to manual operation mode OFF=Automatic mode

The concealed switches which are located underneath the module cover have the following functions:



The valid address range is as follows:

For a module connected to the sub-bus an address in the range 2 .. 99 may be assigned.
 A RIO-29 module connected directly to the myGEKKO bus an address of 1..99 may be assigned.

Parameters	Values
Config 1	Baud Uart1 ON: 115.200kB OFF: 57.600kB
Config 2	RIO29 master mode ON: Module acts as sub-bus master (bus coupler) OFF: Module acts as slave module, such as a RIO16
Config 3	Locking of straight/odd outputs 1-4 ON: 1 and 2, 3 and 4 interlocked OFF: No locking function activated
Config 4	Locking of straight/odd outputs 5-8 ON: 5 and 6, 7 and 8 interlocked OFF: No locking function activated
Adress	Module address on the bus. CAUTION: Address 0 is not permissible for operation

2.2 AX-8

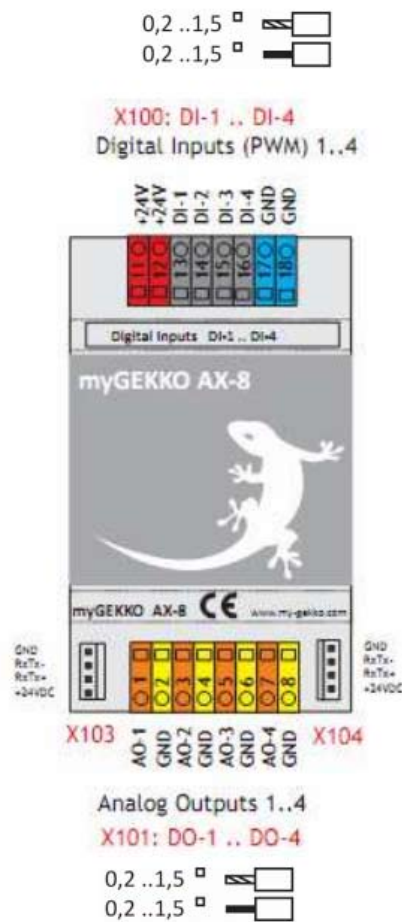

2.2.1 General technical specifications

Parameters	Value	Notes
Supply voltage	24VDC	-25% / +30%
Current consumption (internal)	max. 50mA	Typ. 20mA @ 24VDC
Temperature range during operation	- 20 - 50°	
Storage temperature	- 40 - 85°	
Operating time	100% ED	designed for continuous operation
Degree of protection	IP20	established via appropriate installation
Contamination level	2	
Protection class	II	
Principle of operation	Type 1	EN60730-1

Parameters	Value	Notes
Humidity	max. 75% r.H.	without condensation, during operation
Software class	no software	
Dimensions	54 mm x 110mm x 62mm	L x W x H
Weight	80 g	
EMV	CE according to 2004/108/EG	
Rated surge voltage	0,5kV	
Output PV at 24 VDC	0,5 W	

2.2.2 Digital PWM inputs X100

The PWM inputs translate the PWM outputs of the RIO-29 into a 0-10V signal. The module can only be operated on a RIO-29.

Parameters	Value
Input type	PWM inputs, only from Rio 29
Maximum input voltage	24VDC +30%
Input frequency	500 Hz

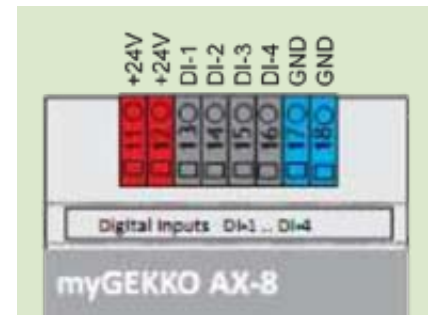

2.2.3 Analog outputs X101

Parameters	Value	Notes
UO - X	Output 0-10 V	12-bit resolution 0 - 4.096
UO - X	max. load 10mA	short-circuit-proof

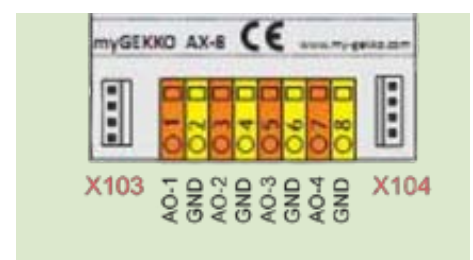

2.2.4 Connection example

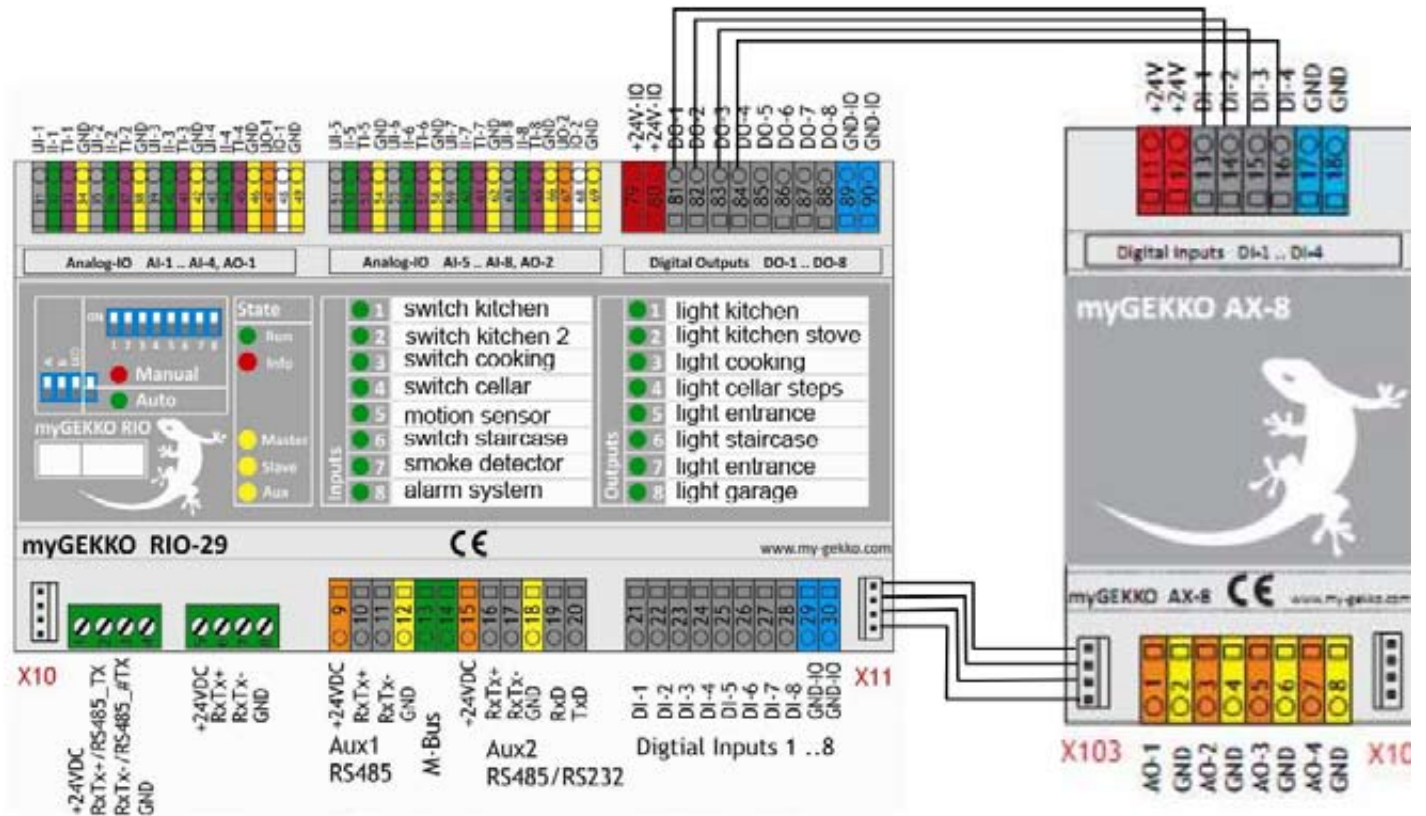

2.2.5 Installation instruction AX-8

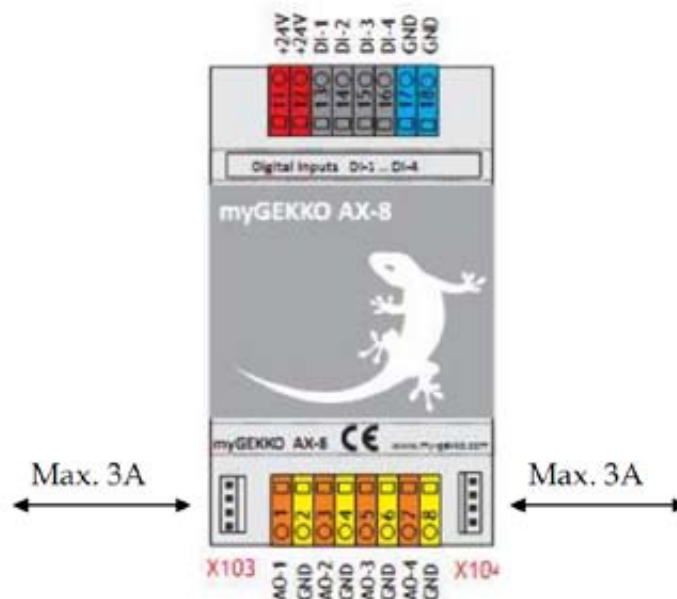

2.2.6 Spring clamp terminals

X100, X101 type 250-210

Stripping length	8,5 mm
Connection data	
Conductor cross section rigid min	0,2 mm ²
Conductor cross section rigid max	1,5 mm ²
Conductor cross section flexible min	0,2 mm ²
Conductor cross section flexible max	1,5 mm ²
Conductor cross section flexible with ferrule without plastic sleeve min	0,25 mm ²
Conductor cross section flexible with ferrule without plastic sleeve max	1,0 mm ²
Conductor cross section flexible with ferrule and plastic sleeve min	0,25 mm ²
Conductor cross section flexible with ferrule and plastic sleeve max	1,0 mm ²
Conductor cross section AWG/kcmil min	20
Conductor cross section AWG/kcmil max	16

2.3 RIO 16

2.3.1 General technical specifications

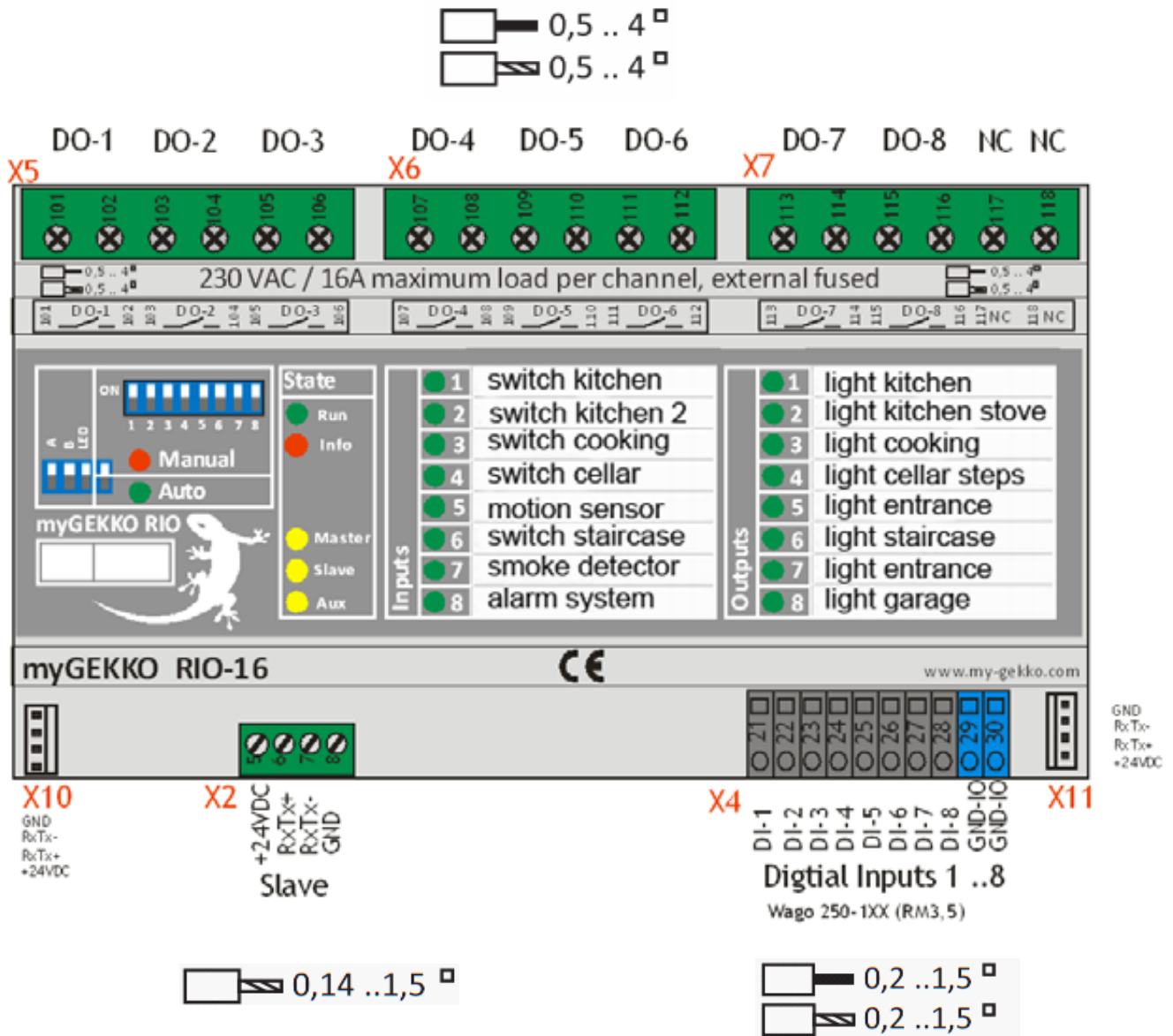

The power current outputs DO-1 to DO-8 must be externally protected with 1*16A each.

Parameters	Value	Notes
Supply voltage	24VDC	-25% / +30%
Current consumption (internal)	Max. 250mA	Typ. 100mA @ 24VDC
Temperature range during operation	-20 - 50°C	
Storage temperature	-40 - 85°C	
Operating time	100% ED	designed for continuous operation
Degree of protection	IP20	established via appropriate installation
Contamination level	2	
Protection class	II	
Principle of operation	Type 1	EN60730-1
Humidity	max. 75% r.H.	without condensation, during operation
Software class	Class A	
Dimensions	162mm x 110mm x 62mm	L x W x H
Weight	380g	
EMV	CE according to 2004/108/EG	
Rated surge voltage	0,5kV	
Output PV at 24 VDC	2 W	

2.3.2 Digital inputs X4

There is a galvanic isolation to the modules of all inputs via opto-couplers.

Parameters	Value
Input type	Optically separated / opto-couplers
Isolation voltage	400V
Switch point On	>9VDC
Switch point Off	<5VDC
Maximum input voltage	24VDC +30%
Current consumption / Input @ 10V	2mA
Current consumption / Input @ 18V	3.8mA
Current consumption / Input @ 24V	5.5mA
Current consumption / Input @ 28V	6.2mA

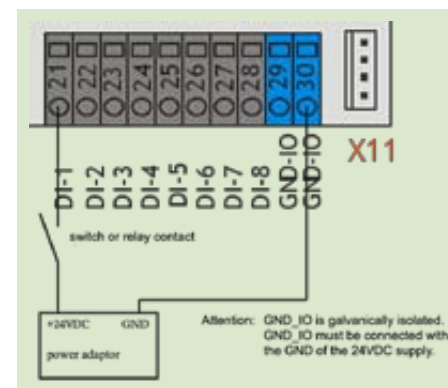

2.3.3 Digital outputs X5, X6, X7

The relay outputs can be realized with “high-current relay.” In order to realize the module possible energy saving, the relay only 1 second can be driven with the nominal coil voltage. If the relay is defined attracted, thus lowering the voltage, the relay module to reduce power consumption.

Parameters	Values	Notes
Output type	relay	16A/230VAC per output
External fusing		Each output has to be fused externally with 1*16A.
Inrush current	factor 10%	25A Max. 4 seconds duty
Max. continuous current		DC or COS(phi) = 1
Max. switching capacity AC		4000VA
Max. operation cycles		50'000

Contact ratings load	Switching cycles
12 A, 250V~, cosφ=1	3x10 ⁵
TV8	25x10 ³
2500 W, 230V~, halogen lamps	>10 ⁴
1000 W, 250V~, incandescent lamps	2,3x10 ⁵
3000 W, 250V~, incandescent lamps	3,6x10 ⁴
1500 VA, fluorescent tubes 163 μF	10 ⁴

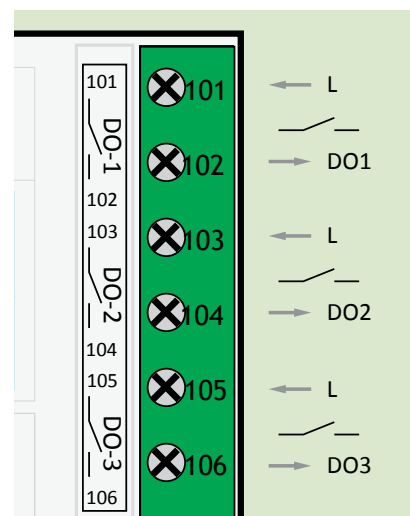

2.3.4 Screw terminals

X2: type MCV1.5/4-ST-3,81

Stripping length	7 mm
Connection data	
Conductor cross section rigid min	0,14 mm ²
Conductor cross section rigid max	1,5 mm ²
Conductor cross section flexible min	0,14 mm ²
Conductor cross section flexible max	1,5 mm ²
Conductor cross section flexible with ferrule without plastic sleeve min	0,25 mm ²
Conductor cross section flexible with ferrule without plastic sleeve max	1,5 mm ²
Conductor cross section flexible with ferrule and plastic sleeve min	0,25 mm ²
Conductor cross section flexible with ferrule and plastic sleeve max	0,5 mm ²
Conductor cross section AWG/kcmil min	28
Conductor cross section AWG/kcmil max	16
2 cables of the same cross section rigid min	0,08 mm ²
2 cables of the same cross section rigid max	0,5 mm ²
2 cables of the same cross section flexible min	0,08 mm ²
2 cables of the same cross section flexible max	0,75 mm ²
2 cables of the same cross section flexible with CES without plastic sleeve min	0,25 mm ²
2 cables of the same cross section flexible with CES without plastic sleeve max	0,34 mm ²
2 cables of the same cross section flexible whit TWIN-CES with plastic sleeve min	0,5 mm ²
2 cables of the same cross section flexible whit TWIN-CES with plastic sleeve max	0,5 mm ²

X5, X6, X7 type PT2.5/6-7.5H

Stripping length	6,5 mm
Connection data	
Conductor cross section rigid min	0,5 mm ²
Conductor cross section rigid max	4 mm ²
Conductor cross section flexible min	0,5 mm ²
Conductor cross section flexible max	4 mm ²
Conductor cross section flexible with ferrule without plastic sleeve min	0,5 mm ²
Conductor cross section flexible with ferrule without plastic sleeve min	2,5 mm ²
Conductor cross section flexible with ferrule without plastic sleeve min	0,5 mm ²
Conductor cross section flexible with ferrule without plastic sleeve min	2,5 mm ²
Conductor cross section AWG/kcmil min	20
Conductor cross section AWG/kcmil max	10
2 cables of the same cross section rigid min	0,5 mm ²
2 cables of the same cross section rigid max	1,5 mm ²
2 cables of the same cross section flexible min	0,5 mm ²
2 cables of the same cross section flexible max	1,5 mm ²
2 cables of the same cross section flexible with CES without plastic sleeve min	0,25 mm ²
2 cables of the same cross section flexible with CES without plastic sleeve max	0,75 mm ²
2 cables of the same cross section flexible with TWIN-CES with plastic sleeve min	0,5 mm ²
2 cables of the same cross section flexible with TWIN-CES with plastic sleeve max	1,5 mm ²

2.3.5 Spring clamp terminals

X4 type 250-210

Stripping length	8,5 mm
Connection data	
conductor cross section rigid min	0,2 mm ²
conductor cross section rigid max	1,5 mm ²
conductor cross section flexibel min	0,2 mm ²
conductor cross section flexibel max	1,5 mm ²
Conductor cross section flexible with ferrule without plastic sleeve min	0,25 mm ²
Conductor cross section flexible with ferrule without plastic sleeve max	1,0 mm ²
Conductor cross section flexible with ferrule and plastic sleeve min	0,25 mm ²
Conductor cross section flexible with ferrule and plastic sleeve max	1,0 mm ²
Conductor cross section AWG/kcmil min	20
Conductor cross section AWG/kcmil max	16

2.3.6 Installation specifications RIO-16

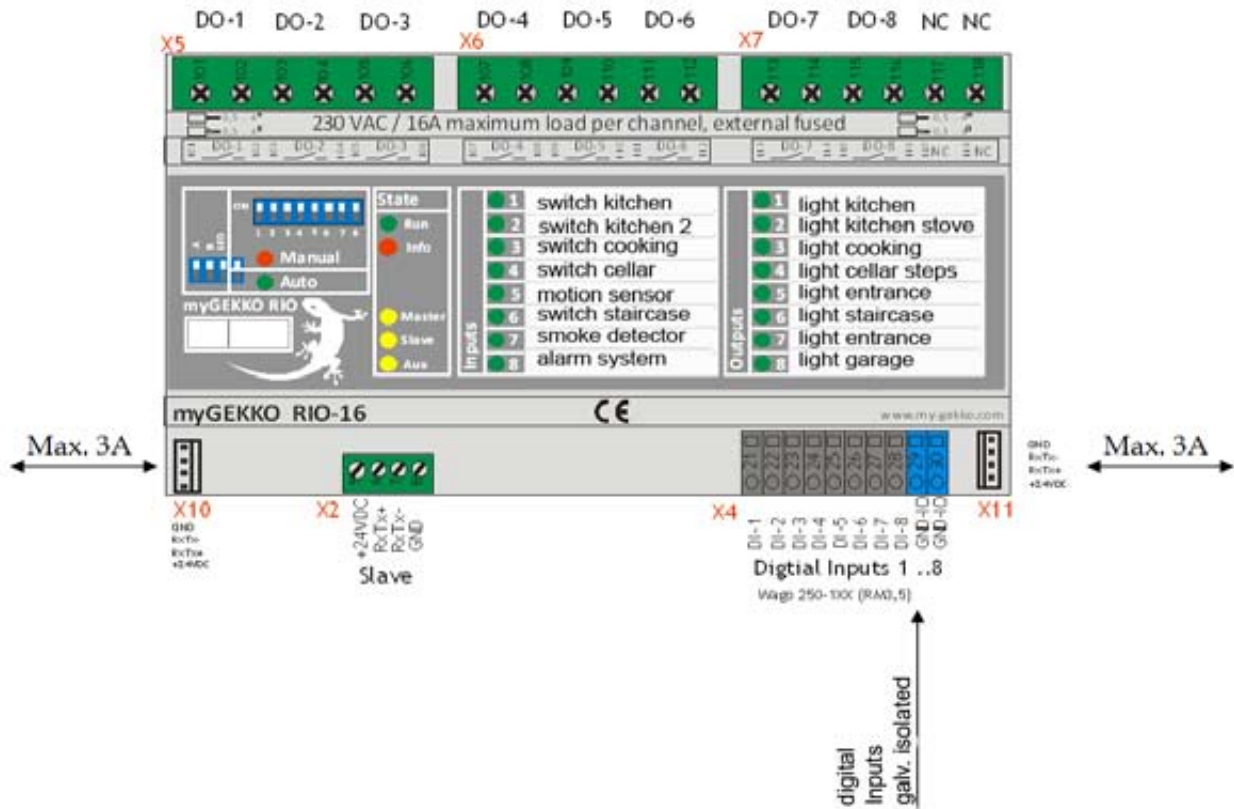

Note that the module linking via the connectors X10 and X11 is only permissible up to a current of 3A. If the 3A are exceeded, separate supply at X1 or X2 (sub-bus) has to be established.

2.3.7 Functional description Dip switch RIO 16

The DIP-switches are activated when the corresponding switches are pushed upwards.

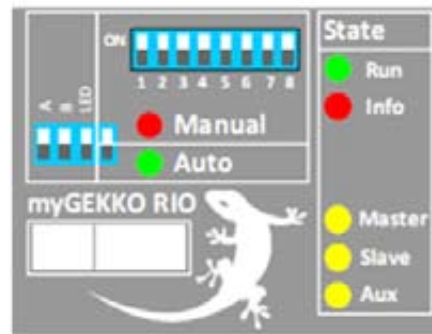

Parameters	Value
Manual operation switch 1..8	State of the corresponding output in manual mode or at bus timeout. ON = Output ON OFF = Output OFF
A	Behaviour of outputs in case of communication interruption. ON = Outputs retain current state (not remanent) OFF = Outputs attain the set manual mode.
B	Reserve (without functionality)
LED	State of the status LED on the module. ON = All LEDs are switched off OFF=All LEDs show the current module state
Manual	Manual operation ON = Switches all outputs to manual operation mode OFF=Automatic mode

The concealed switches which are located underneath the module cover have the following functions:



The valid address range is as follows:

For a module connected to the sub-bus an address in the range 2 .. 99 may be assigned.

A RIO-29 module connected directly to the myGEKKO bus an address of 1..99 may be assigned.

Parameters	Value
Config 1	Emergency control system
Config 2	Emergency control system
Config 3	Locking of straight/odd outputs 1-4 ON: 1 and 2, 3 and 4 interlocked OFF: No locking function activated
Config 4	Locking of straight/odd outputs 5-8 ON: 5 and 6, 7 and 8 interlocked OFF: No locking function activated
Adress	Module address on the bus. CAUTION: Address 0 is not permissible for operation

Emergency control system RIO-16

Config 1	Config 2	User A (Fail-mode)	Description
0	0	0	Outputs switch to the state of the manual switches
0	0	1	Outputs maintain the last state received from myGEKKO
1	0	X	SR-Light direct mode (DI->DO toggle)
0	1	X	Rollo mode
1	1	X	Reserve. At the moment: Outputs switch to the state of the manual switches (if fail mode '0')

SR-Light direct mode (DI->DO toggle)

- Outputs are switched as pushbutton function of inputs. Impulse at input x toggled state on output x (relay closed / relay opened).

Rollo-Mode

- 1.Input switches as pushbutton function of 1.output (same for all 8 inputs and outputs)
- short keystroke -> short operation
- long keystroke (>1s) -> output switched for 5 min. or until keystroke on input 1 (or keystroke on input 2 in case of activated locking)
- The Odd-Even-Lock of the outputs must be activated via Config 3 and Config 4.

2.4 Functional description LED's

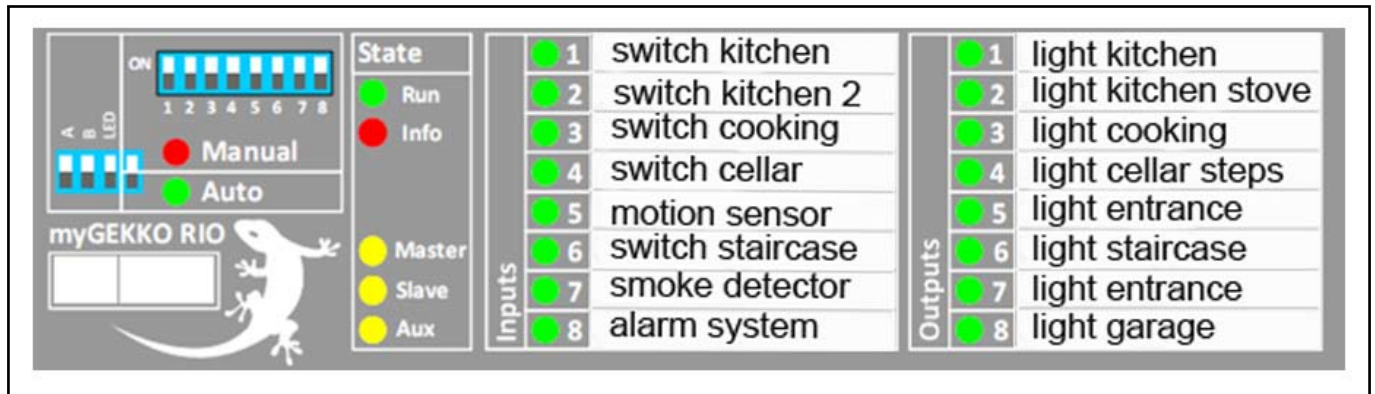

Parameters	Value
Run	LED on, module active no fault condition
Info	LED blinking, Odd/Even Lock active, i.e. 2 outputs mutually active
Manual	LED on, outputs manual operation, i.e. such as switch position „ON“
Auto	LED on, outputs are set via bus
Master	LED blinking, if interface is currently communicating
Slave	LED blinking, if interface is currently communicating
Aux	LED blinking, if interface is currently communicating
Inputs	LED on, corresponding input active
Outputs	LED on, corresponding output active

2.5 Bus wiring

It is of high importance that the bus cabling is linear, i.e. the bus has a start and an end point. Star-shaped bus wiring as well as ring wiring have to be avoided to prevent interferences.

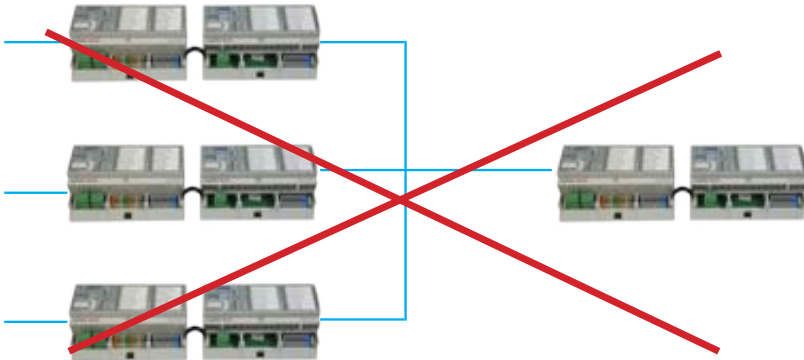

no star wiring!!

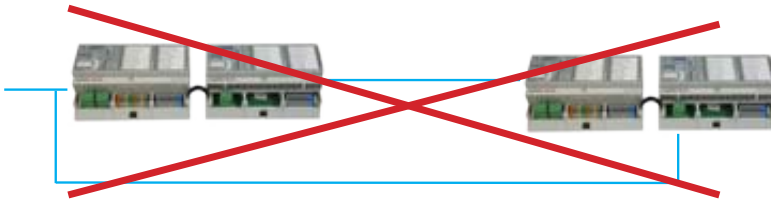

no ring wiring!!



Bus wiring

Recommended cable type for data connection:

Profibus L2FIP 1x2x0,65

Note:

Install bus terminating resistors at the start and end points of the bus in case of communication problems or long connection lines to myGEKKO (> 20 meters). The resistor must be connected as follows:

For slave bus:

1 resistor on the master RIO-29 at the slave bus connector and 1 resistor on the last RIO-16 or RIO-29 at the slave connector wired in series.

For master bus:

1 resistor on myGEKKO Touch and 1 resistor at the last master connector wired in series.

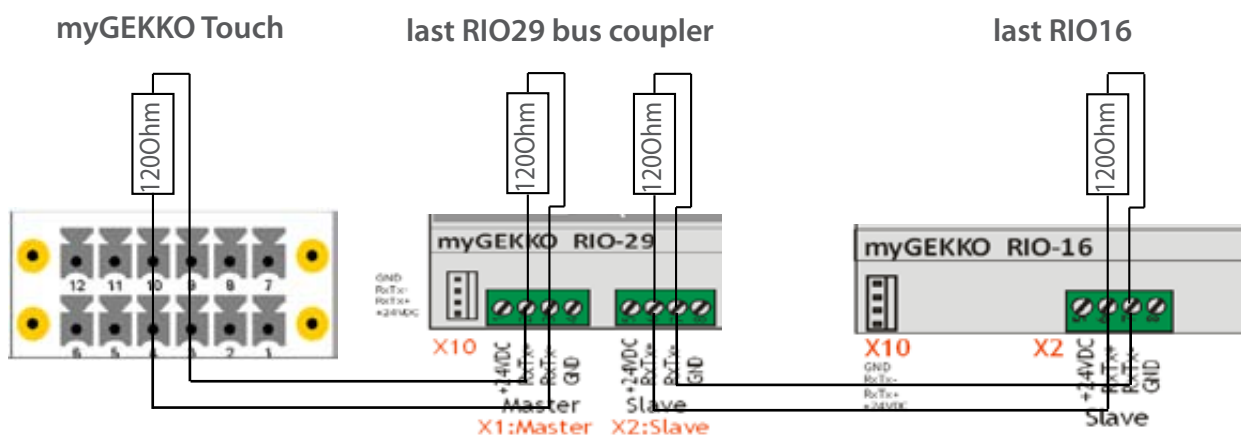

2.6 Configuration example setting of bus addresses

- Max. 4 bus-lines per myGEKKO Touch
- Max. 16 modules per bus-lines

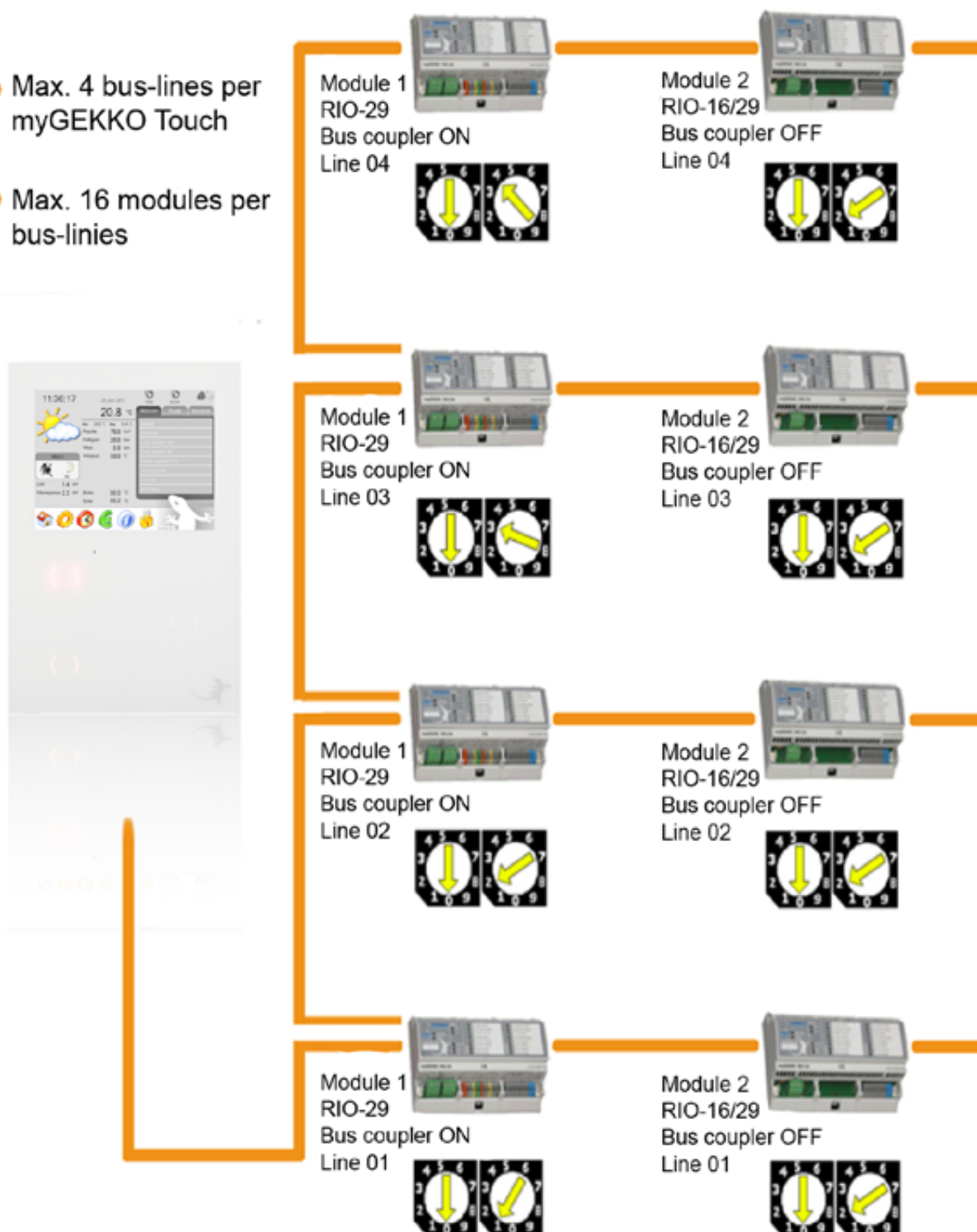

The RIO-29 must be always the first module in the line and act as a bus coupler
As bus coupler it define the line adress.

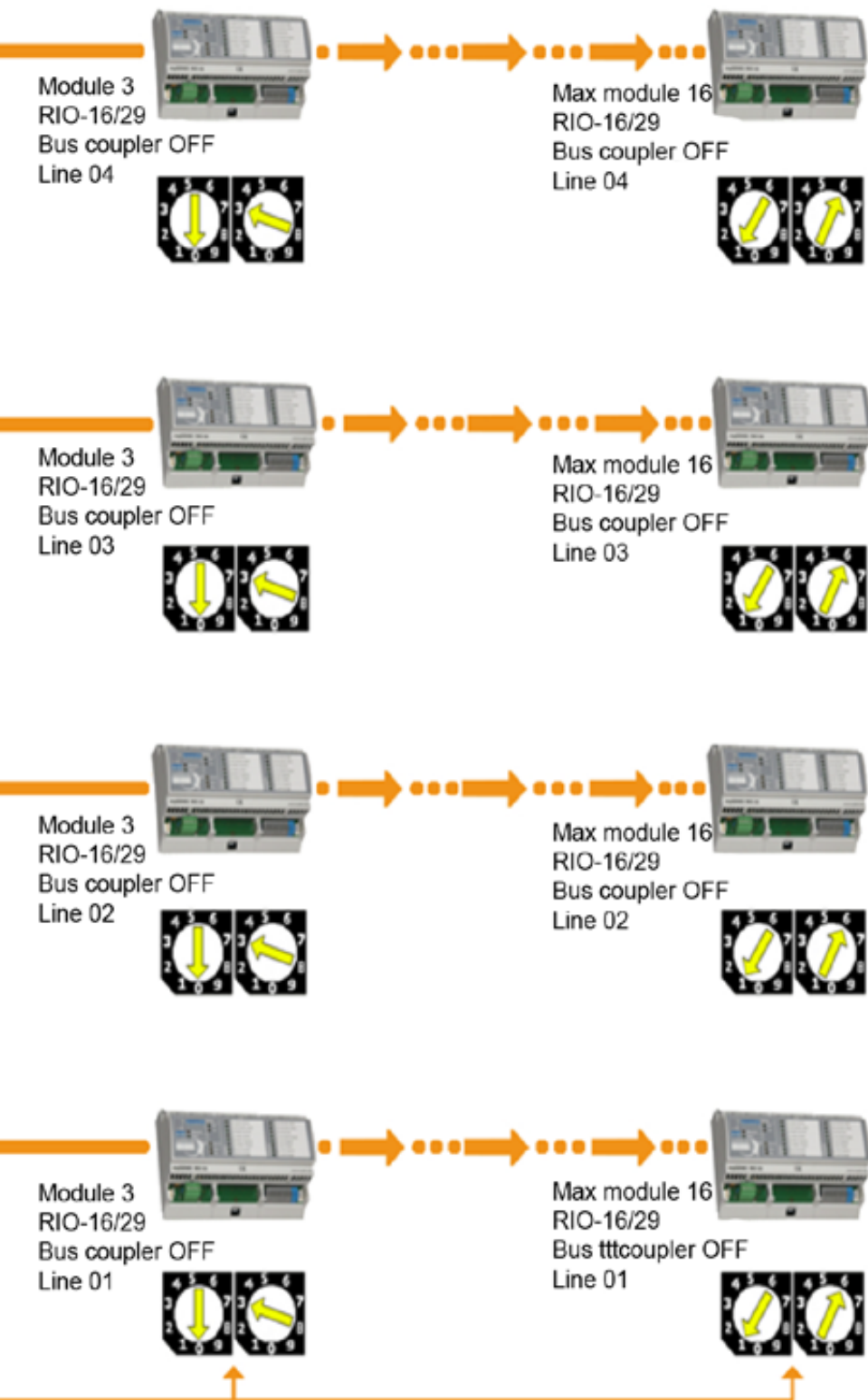

The RIO-16 or RIO-29 (with bus coupler on OFF) are the module addresses in this busline.
Maximum 16 modules per busline.

2.7 Schematic example: Protection of the 24VDC circuit

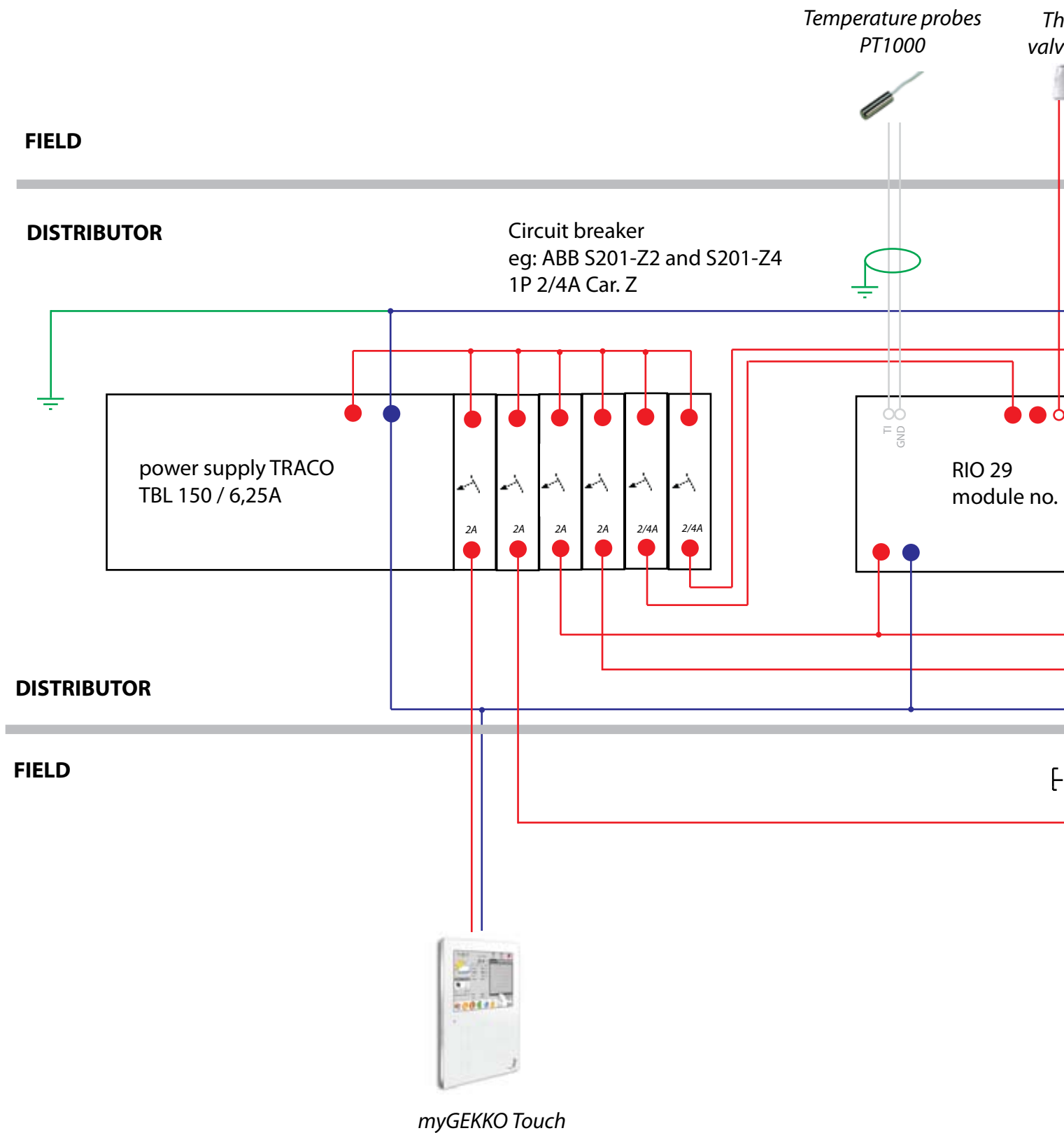

its with circuit breaker or extra fuse

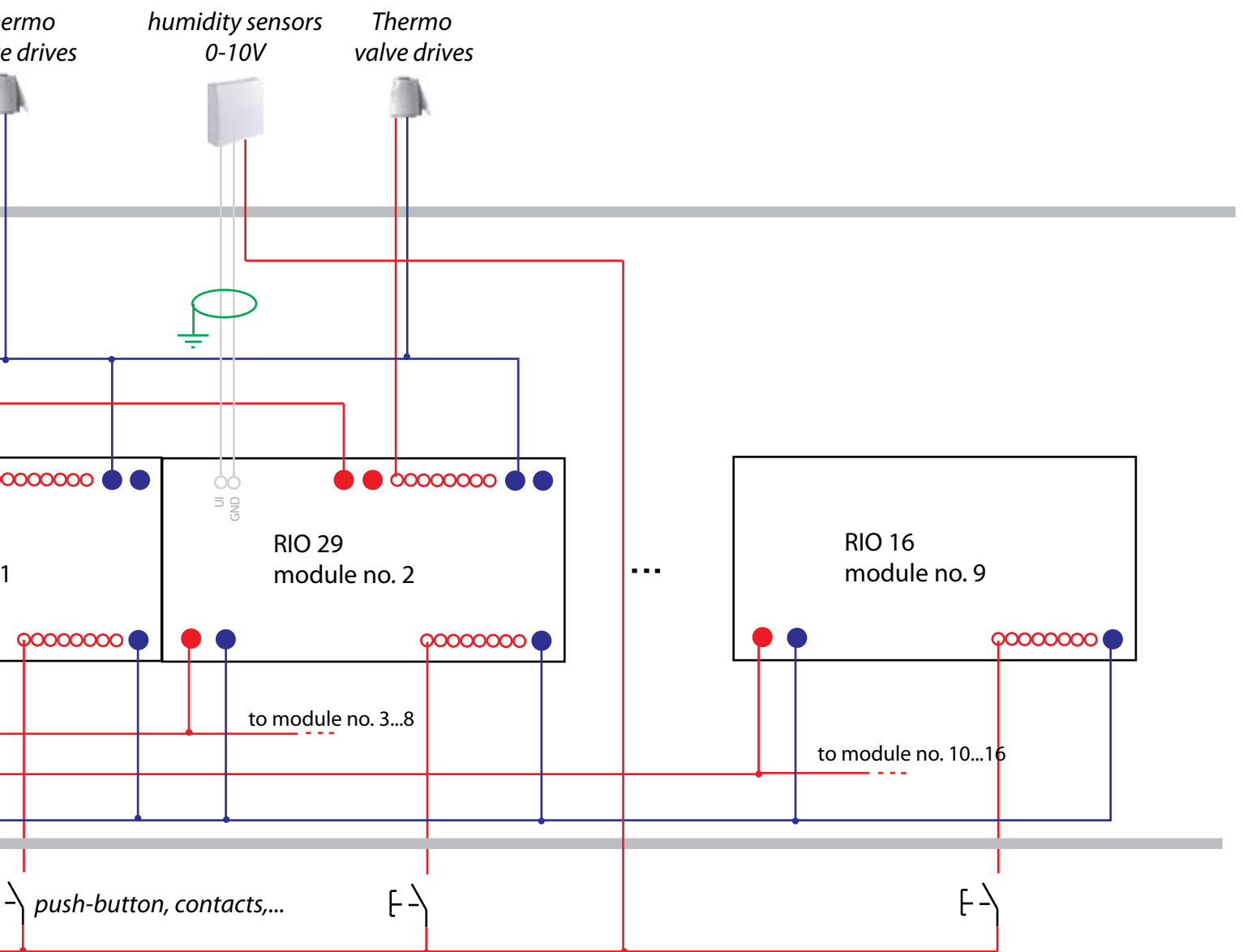

Fuse circuits:

- 1) myGEKKO Touch
- 2) Devices in the field like push-buttons, contacts, sensors, ..
- 3) feed-in modules RIO 1..8
- 4) feed-in modules RIO 9..16
- 5) Thermal valve drives first RIO29
- 6) Thermal valve drives second RIO29

3. Installation manual

3.1 User-circle

Installation and assembly of electrical equipment may only be performed by a qualified electrician. Non-observance of this manual could cause damage to the device and cause fire or other hazards.



This manual is part of the product and has to remain with the end user.

The applicable electrical regulations for domestic installation are to be respected.

3.2 General safety information

There are live parts inside the housing. Touching terminals may be fatal if the system is not disconnected from the mains. There are no serviceable parts inside the device. The opening of the housing is thus only allowed to employees of the manufacturer.



Caution! External voltage on the RIO!

For the performance of service work on RIO modules or the connected peripherals all connections must be disconnected from the main supply. Include all circuit breakers which provide dangerous voltages to the device.

Power supply must not be applied to the terminals as long as the earth connector is not earthed properly according to instructions.

3.3 Installation procedure

The devices are designed for stationary operation and must be mounted that the touching of the energized terminals in normal operation is impossible.



In general, the RIO modules are installed under covers. During installation, ensure particular that the devices are protected from environmental influences like water, humidity and dirt.

The units may be connected in the supply voltage condition. Depending on the installation the modules can either snapped onto DIN-rails (C-35) or screwed (surface) on a mounting panel. The cable relief of the connecting cables must be made during installation. The modules have no cable relief.

3.4 External fuse

The 24VDC power supply of the RIO modules must be secured externally according to the cross section of the connection wires and the maximum current consumption of the device.



It has to be ensured that for each output DO-1 to DO-8 of the RIO-16 current is limited by external protection to a maximum of 16A.

All connecting wire cross sections have to be chosen in regard of the maximum current.

4. Software activation at myGEKKO

The modules are ready for use if all modules are connected and configured.

1. Go to main settings and select IO configuration (green/blue arrows)
2. At IO Station 1 select -> "myGEKKO RIO". If you use several bus lines you need to select "myGEKKO RIO" also at the other stations 2 to 4 according to the number of bus lines used.
3. Select next to "myGEKKO RIO" the port on which you have connected the RIOs. By default, it is the COM PORT 2 directly on the Touch. If you use several bus lines (IO stations) choose from there as well the particular port on which the bus line is connected.
4. Tap "Configure>>" then "Scan". All connected RIO modules should now be detected and listed. If the RIOs are correctly identified an "OK" will appear next to each detected RIO.
5. Tap "Save".
6. Done! You can now use the RIO modules in the single system menus.



Selection of the RIOs at the Com Port 2



Scanning the RIO modules



my **GEKKO**[®]



www.my-gekko.com



A first class product of Europe!
The result of a close collaboration between
Italy, Switzerland and Germany

