

Device/PLC Connection Manuals



About the Device/PLC Connection Manuals

Prior to reading these manuals and setting up your device, be sure to read the "Important: Prior to reading the Device/PLC Connection manual" information. Also, be sure to download the "Preface for Trademark Rights, List of Units Supported, How to Read Manuals and Documentation Conventions" PDF file. Furthermore, be sure to keep all manual-related data in a safe, easy-to-find location.

7.8 Rockwell (Allen-Bradley)





With Rockwell SLC5/05 Ethernet Protocol units, when the same project file is used on multiple GP/GLC units, the system may malfunction. When using multiple GP/GLC units, create and maintain only one unique project file for each GP/GLC unit.

7.8.1 System Structure

This section explains the system structures available for the Ethernet connection between Rockwell (Allen-Bradley) PLCs and GP/GLC units.

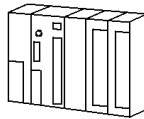
■ SLC500 Series

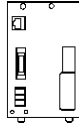
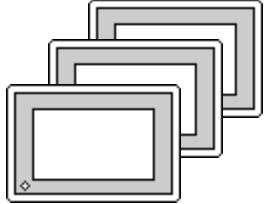
CPU	Link I/F	Cables	Unit	GP
				
SLC5/05	Ethernet I/F on CPU unit	Ethernet cable (IEEE802.3 Compliant)	Pro-face Ethernet I/F Unit GP070-ET41 GP377-MLTE11 GP377-MLTE41 GP077-MLTE41	GP/GLC Series *1

*1 When using GP/GLC and the optional Ethernet I/F unit, refer to the following List of Connectable GP/GLC Units.

Series Name		Product Name	Optional Ethernet I/F Unit	Built-in Ethernet Port
GP77R Series	GP-377R Series	GP-377RT	○ ^{*1 *2}	x
	GP-477R Series	GP-477RE	○ ^{*2}	x
	GP-577R Series	GP-577RS	○ ^{*2}	x
		GP-577RT	○ ^{*2}	x
GP2000 Series	GP-2300 Series	GP-2300L	x	○
		GP-2300S	x	○
		GP-2300T	x	○
	GP-2400 Series	GP-2400T	x	○
	GP-2500 Series	GP-2500L	○ ^{*3 *4}	○
		GP-2500S	○ ^{*3 *4}	○
		GP-2500T	○ ^{*3 *4}	○
	GP-2501 Series	GP-2501L	○ ^{*2 *3}	x
		GP-2501S	○ ^{*2 *3}	x
		GP-2501T	○ ^{*2 *3}	x
	GP-2600 Series	GP-2600T	○ ^{*3 *4}	○
	GP-2601 Series	GP-2601T	○ ^{*2 *3}	x
GLC2000 Series	GLC-2300 Series	GLC-2300L	x	○
		GLC-2300T	x	○
	GLC-2400 Series	GLC-2400T	x	○
	GLC-2500 Series	GLC-2500T	○ ^{*3 *4}	○
	GLC-2600 Series	GLC-2600T	○ ^{*3 *4}	○
ST Series		ST403	x	○

*1 Only the Multi Unit can be used.

*2 The 2-Way Driver (Pro-Server, GP-Web and others) cannot be used.

*3 When using the optional Ethernet I/F unit, a bus conversion unit (PSL-CONV000) is required.

*4 Using the optional Ethernet I/F Unit allows you to set up separate Class and Net No.s for 2-Way Driver applications (Pro-Server, GP-Web and others) and the PLC. When doing this, data transfer with the PLC is performed through the optional Ethernet I/F Unit.



- For cable connection and Optional Unit information, refer to the User Manual for each optional unit. For GP2000 and GLC2000 series units, refer to that unit's User Manual.

◆ **Connection Structure**

<1 : 1 connection>

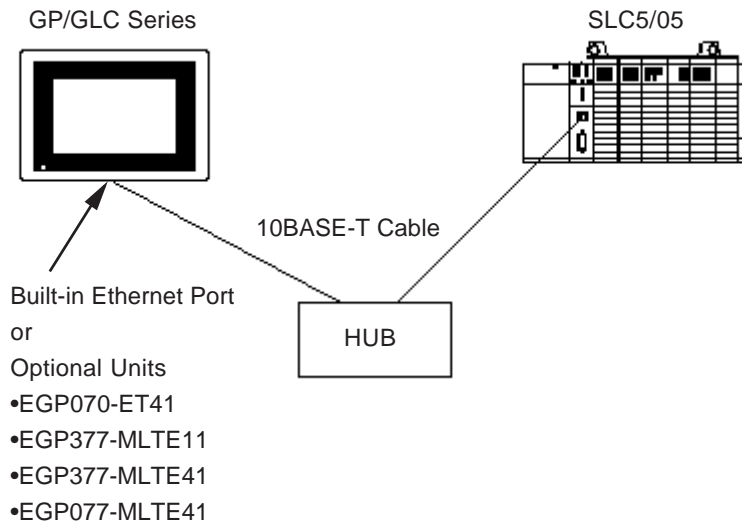

<1:n connection>

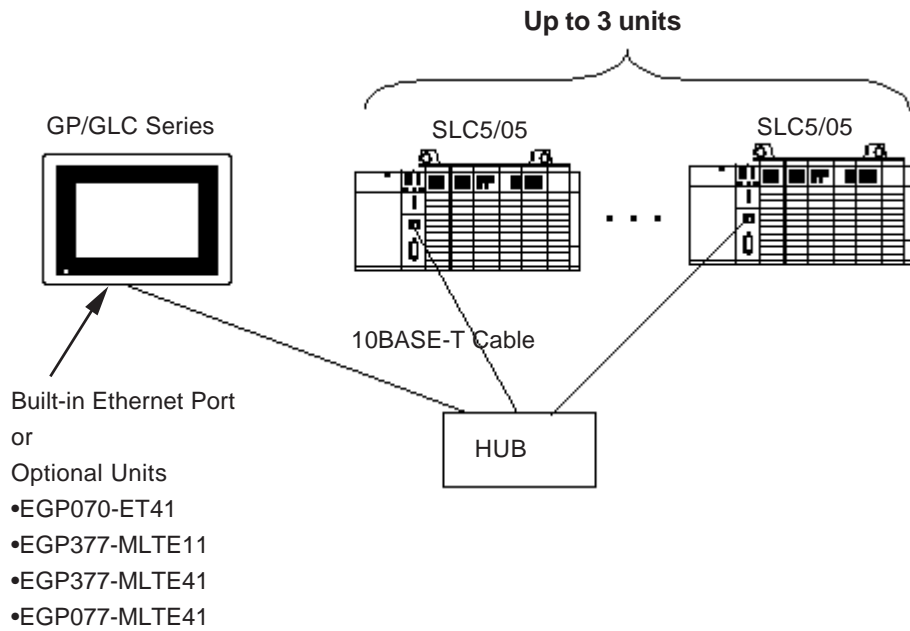

<n:1 connection>

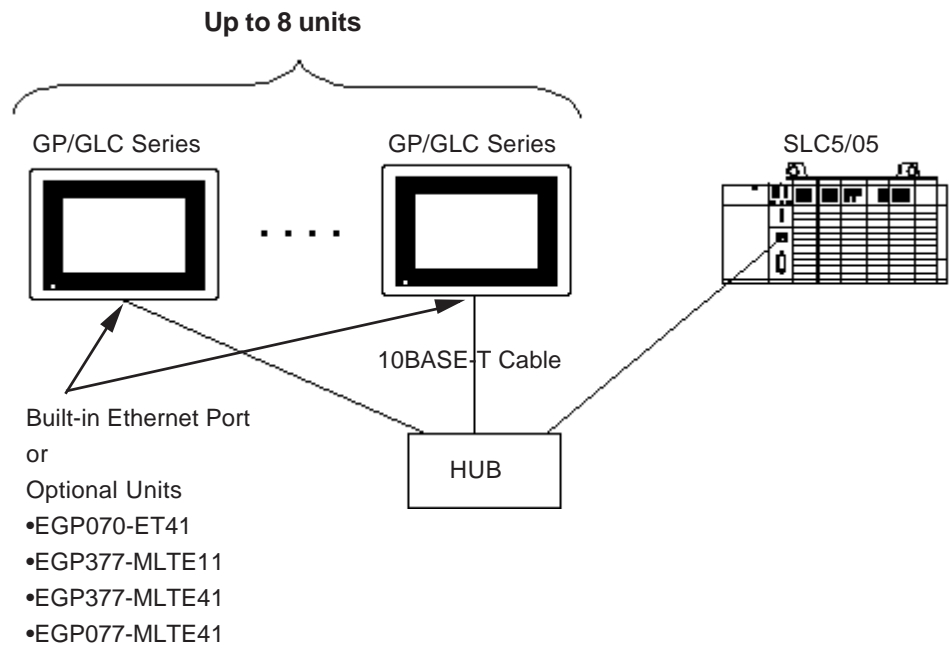

■ **Control Logix 5000 Series**

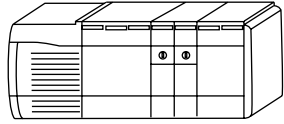
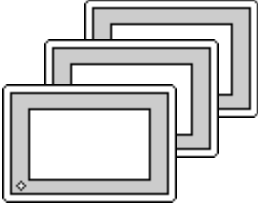
CPU	LinkI/F	Cables	GP
	←→		
1756-L1 1756-L1M1 1756-L1M2 1756-L1M3 1756-L55M13 1756-L55M14 1756-L55M16	1756-ENET 1756-ENBT	Ethernet cable (IEEE802.3 Compliant)	GP/GLC Series ^{*1}

■ **Compact Logix Series**

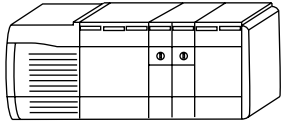
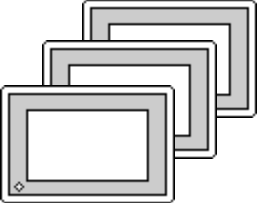
CPU	LinkI/F	Cables	GP
	←→		
1769-L35E	Ethernet Port on CPU	Ethernet cable (IEEE802.3 Compliant)	GP/GLC Series ^{*1}

**1 Refer to the following List of Connectable GP/GLC Units.*

Series Name		Product Name
GP2000 Series	GP-2300 Series	GP-2300L
		GP-2300S
		GP-2300T
	GP-2400 Series	GP-2400T
	GP-2500 Series	GP-2500L
		GP-2500S
GP-2500T		
GP-2600 Series	GP-2600T	
GLC2000 Series	GLC-2300 Series	GLC-2300L
		GLC-2300T
	GLC-2400 Series	GLC-2400T
	GLC-2500 Series	GLC-2500T
	GLC-2600 Series	GLC-2600T
ST Series		ST403



Note: • **Optional Ethernet I/F Unit cannot be used.**

◆Connection Structure

<1 : 1 connection>

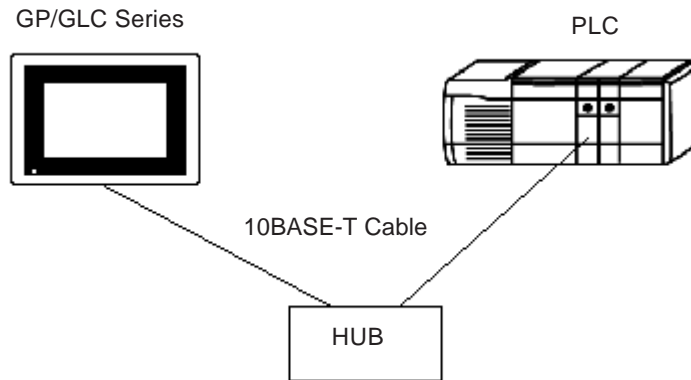

<n:1 connection>

Control Logix 5000: Up to 64 units
Compact Logix: Up to 32 units

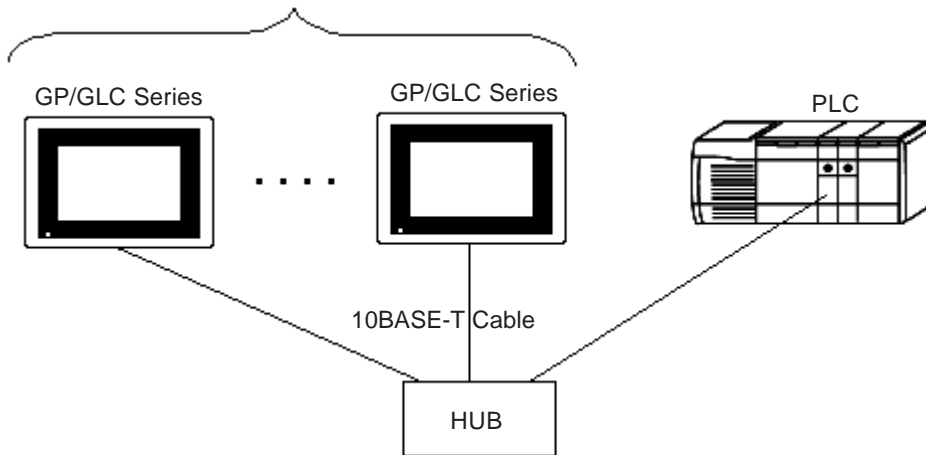

Note:

- When connecting multiple GP Units, the load on the PLC unit increases. Depending on the work environment, the PLC unit's data transfer processing may not be completed in time, and a data transfer error (Host Communication Error 02:D0:##:01:0301 or 02:0D:##:01:0204. **Reference** 7.8.4 Error Codes) may occur on the GP unit. If this phenomenon occurs, be sure to increase the GP unit's send wait time.
- The Max. No. of units indicated is when only GP Series units are connected. Connecting other devices via an ethernet connection will further reduce the maximum number of GP Series units that can be connected.

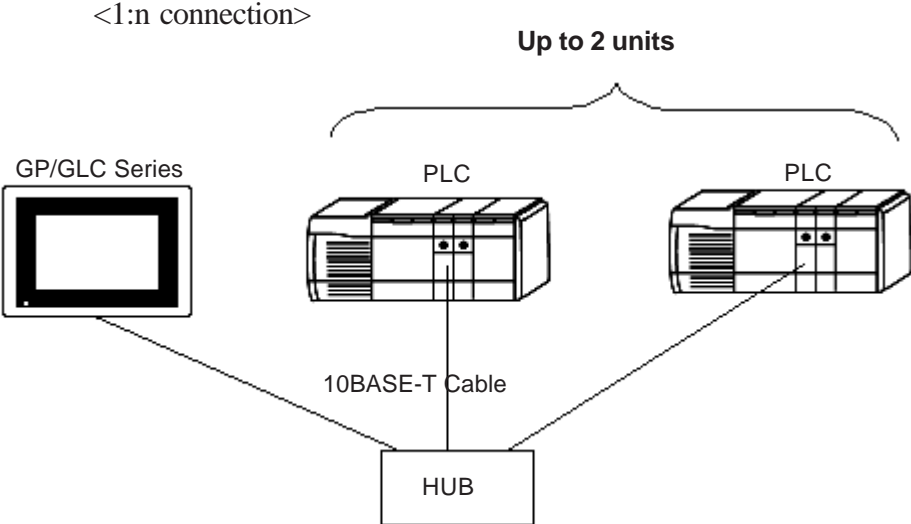

7.8.2 Supported Devices

The following list shows the range of devices supported by the GP/GLC.

■ SLC500 Series

Setup System Area here.

Device	Bit Address	Word Address	Others
Bit	B3:0/0 - B3:255/15 B9:0/0 - B255:255/15	B3:0 - B3:255 B9:0 - B255:255	H/L
Timer (TT : Timing Bit)	T4:0/TT - T4:255/TT T9:0/TT - T255:255/TT	-	L/H
Timer (DN : Complete Bit)	T4:0/DN - T4:255/DN T9:0/DN - T255:255/DN	-	
Timer (EN : Enable)	T4:0/EN - T4:255/EN T9:0/EN - T255:255/EN	-	
Timer (PRE : Setup Value)	-	T4:0.PRE - TP4.255.PRE T9:0.PRE - T255.255.PRE	
Timer (ACC : Current Value)	-	T4:0.ACC - T4:255.ACC T9:0.ACC - T255:255.ACC	
Counter (CU :Up Count)	C5:0/CU - C5:255/CU C9:0/CU - C255:255/CU	-	
Counter (CD : Down Count)	C5:0/CD - C5:255/CD C9:0/CD - C255:255/CD	-	
Counter (DN : Complete Bit)	C5:0/DN - C5:255/DN C9:0/DN - C255:255/DN	-	
Counter (OV : Overflow)	C5:0/OV - C5:255/OV C9:0/OV - C255:255/OV	-	
Counter (UN : Underflow)	C5:0/UN - C5:255/UN C9:0/UN - C255:255/UN	-	
Counter (UA : Update)	C5:0/UA - C5:255/UA C9:0/UA - C255:255/UA	-	
Counter (PRE : Setup Value)	-	C5:0.PRE - C5.255.PRE C9:0.PRE - C255:255.PRE	
Counter (ACC :Current Value)	-	C5:0.ACC - C5:255.ACC C9:0.ACC - C255:255.ACC	
Control (DN : Complete Bit)	R6:0/DN - R6:255/DN R9:0/DN - R255:255/DN	-	
Control (EN :Enable)	R6:0/EN - R6:255/EN R9:0/EN - R255:255/EN	-	
Control (ER : Error)	R6:0/ER - R6:255/ER R9:0/ER - R255:255/ER	-	
Control (UL : Unload)	R6:0/UL - R6:255/UL R9:0/UL - R255:255/UL	-	
Control (IN : In High Bit)	R6:0/IN - R6:255/IN R9:0/IN - R255:255/IN	-	
Control (FD : Found)	R6:0/FD - R6:255/FD R9:0/FD - R255:255/FD	-	
Control (EU : Unload Enabled)	R6:0/EU - R6:255/EU R9:0/EU - R255:255/EU	-	
Control (EM: Empty Slack)	R6:0/EM - R6:255/EM R9:0/EM - R255:255/EM	-	
Control (LEN : Length)	-	R6:0.LEN - R6:255.LEN R9:0.LEN - R255:255.LEN	
Control (POS : Position)	-	R6:0.POS - R6:255.POS R9:0.POS - R255:255.POS	
Integer	-	N7:0 - N7:255 N9:0 - N255:255	H/L
Floating Decimal Point	-	F8:0 - F255:255	L/H



Important

When using Pro-Server with Pro-Studio:

- To access any of the above devices, Pro-Server with Pro-Studio Ver. 4.1 or higher is required. Also, additional settings are required. For setting details, please refer to the Pro-Server with Pro-Studio Ver. 4.1 or higher software's Operation Manual.
- Using versions prior to Pro-Server with Pro-Studio Ver. 4.1 allows you to only access the LS Area.

◆ **When setting Parts or Tags from GP-PRO/PBIII for Windows**

Before setting up Parts or Tags, Network Information settings must be entered. Network Information settings can be entered from the [GP SYSTEM SETTING]->[MODE SETTING]->[Network Information] screen.

Reference *this manual, 7.8.3 Environment Setup*

Setting up Parts or Tags by specifying the PLC's Node Address allows the specified PLC's Device data to be read out.

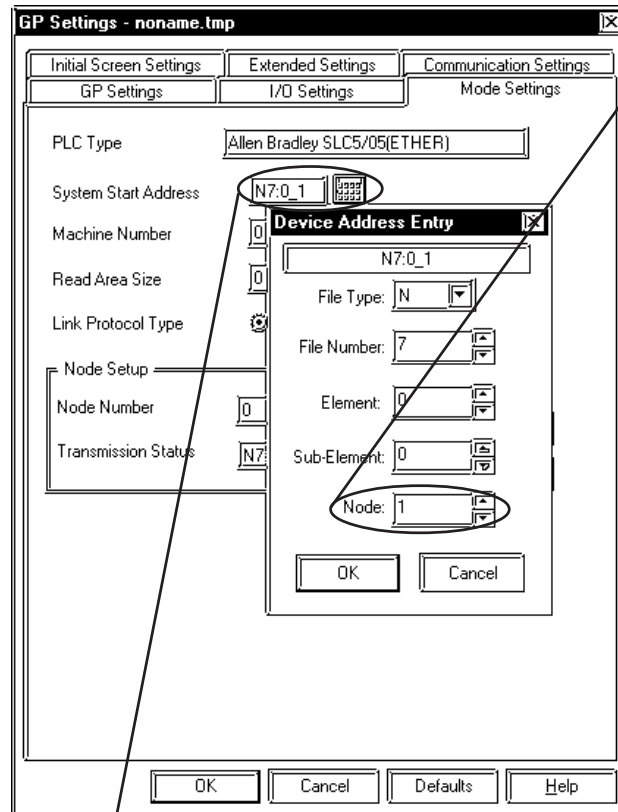

The System Area and Read Area are assigned to the PLC node designated here. Node Numbers are set via the [Mode Settings] - [Network Information] screen.

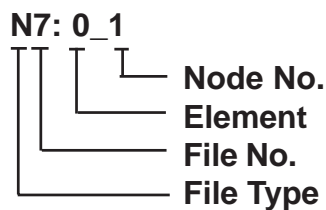



Note: • Rockwell (Allen-Bradley) PLC device data consists of elements. When entering devices and addresses in GP-PRO/PBIII for Windows, use the following method.

- When using Word Devices N, B or F

Device Address Entry

N7:0/0_1

File Type: N

File Number: 7

Element: 0

Sub-Element: 0

Node: 1

OK Cancel

(Display after entry)

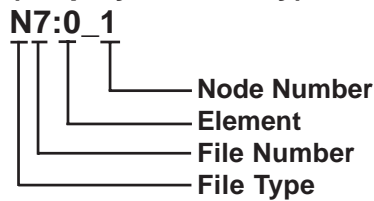

- When using Word Devices T, C or R

Device Address Entry

T4:0.PRE_1

File Type: T

File Number: 4

Element: 0

Sub-Element: PRE

Node: 1

OK Cancel

(Display after entry)

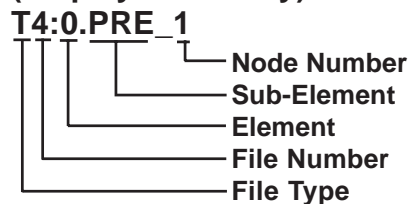

- When using Word Devices N or B

Device Address Entry

B3:0/0_1

File Type: B

File Number: 3

Element: 0

Bit: 0

Node: 1

OK Cancel

(Display after entry)

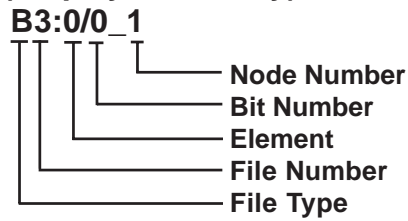

- When using Bit Devices T, C or R

Device Address Entry

T4:0/TT_1

File Type: T

File Number: 4

Element: 0

Sub-Element: TT

Node: 1

OK Cancel

(Display after entry)

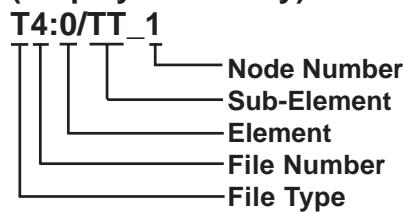

■ SLC500 Series Ethernet Protocol Limitation

Even though the SLC500 Series Ethernet Protocol can access more than one CPU, the following limitations apply.

1. Device Address and Node Number Limitations

When a different File Number or Node Number is set, the number of available device addresses will vary. The GP uses internal records to set the device addresses. These records are limited to 64. For example, when the N7:0 device address is set, a single record is used in the GP. For detailed examples, refer to the following chart.

Ex1.) Number of records used when designating tag setting numbers.

Setting No.	Node No.	Device Address	Remaining Number of records in GP-PRO/PBIII	Remarks
1	1	N7:0	63	Uses one record
2	1	N9:0	62	Uses one record
3	2	B10:0	61	Uses one record
4	2	B11:0	60	Uses one record
5	1	N7:255	60	Since the node number and element number range already exist as setting No.1, no records will be used.
6	2	B10:255	60	Since the node number and element number range already exist as setting No.3, no records will be used.
7	3	N12:0	58	Uses one record

When using a different Node Number or File Number, GP internal records are used.

Ex2.) When setting tags from N10 to N19 (File Number), a total of 10 records will be used. Therefore, when setting tags continuously from N10 (File Number), File Numbers can be used up to N73.



When the number of records exceeds 65, the following error message will appear on the GP Screen Editor software (GP-PRO/PBIII for Windows).

“Address entry limit reached. No more can be entried”

■ Control Logix 5000 Series / Compact Logix Series

 Setup System Area here.

Device	Bit Address	Word Address	Remarks
Bit (BOOL)	BOOL00000000-BOOL99999931	BOOL000000-BOOL999999	*1*3
8 bit integer (SINT)	_____	SINT000000-SINT999998	Bit 7 ÷ 2 *1
16 bit integer (INT)	_____	INT000000-INT999999	Bit 15 *1
32 bit integer (DINT)	_____	DINT000000-DINT999999	Bit 32 *1
32 bit float (REAL)	_____	REAL000000-REAL999999	*1*2 H/L

*1 When using a GP Series unit to access a ControlLogix 5000 Series unit's data memory, you must first allocate data memory's array elements.

Reference ◆ Device Setting Example (P.7-8-14)

When allocating array elements, use File numbers and Element numbers. An address designation example is shown below for GP-PRO/PBIII for Windows.

INT 123 100
└─┬─┘ Element number (0~999)
└─┬─┘ File number (0~999)

*2 This device uses Float. When this type of device is used, only the E-tag and K-tag's "32-bit Float" setting can be used.

*3 The BOOL device descriptions used in the GP-PRO/PBIII manual and the RSLogix 5000 manual are different. Please be aware of these differences when setting up BOOL devices.

GP-PRO/PBIII manual	0:0/00-0:00/31	0:1/00-0:1/31	0:2/00-0:2/31	~	0:999/00-0:999/31
RSLogix 5000 manual	0-31	32-63	64-95	~	31968-31999



- **When using the GP to access a PLC device, be sure to first allocate all Tags used by PLC Data Memory to their respective devices. Use the Rockwell's RSLogix 5000 ladder logic software to allocate these devices.**

If device allocation is not performed, a Host Communication Error will occur (02:D6).

Reference 7.8.5 Error Codes

- **When using Pro-Server with Pro-Studio:**

-To access any of the above devices, Pro-Server with Pro-Studio Ver. 4.1 or higher is required. Also, additional settings are required. For setting details, please refer to the Pro-Server with Pro-Studio Ver. 4.1 or higher software's Operation Manual.

-Using versions prior to Pro-Server with Pro-Studio Ver. 4.1 allows you to only access the LS Area.

◆ **When setting Parts or Tags from GP-PRO/PBIII for Windows**

Before setting up Parts or Tags, Network Information settings must be entered. Network Information settings can be entered from the [GP SYSTEM SETTING]->[MODE SETTING]->[Network Information] screen.

▼ **Reference** ▲ *this manual, 7.8.3 Environment Setup*

Setting up Parts or Tags by specifying the PLC's Node Address allows the specified PLC's Device data to be read out.

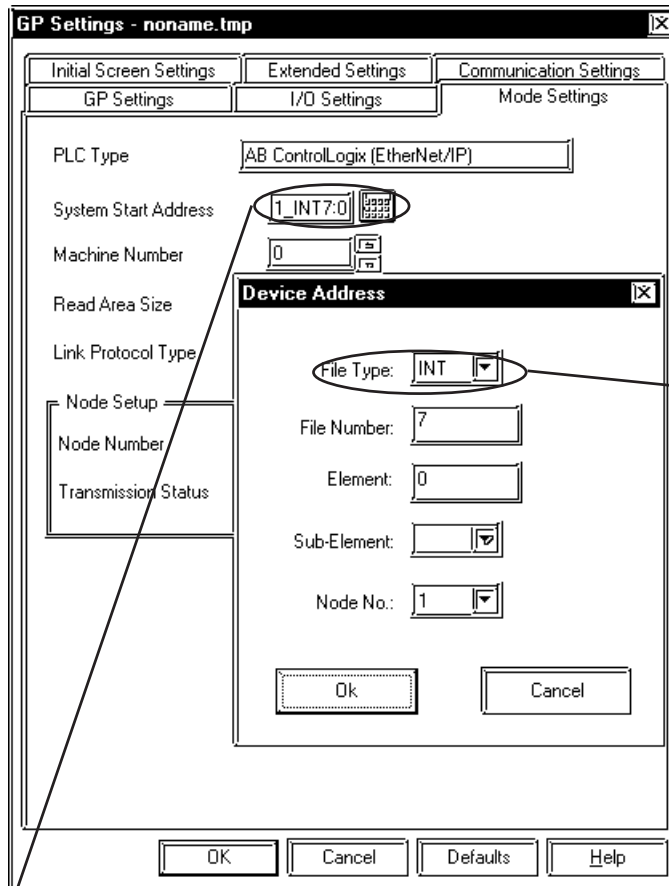

The system start address is allocated to the IP Address PLC designated in the Node Number. Node Numbers are set via the [Mode Settings] - [Network Information] screen.

(Display after entry)

1_INT7:0

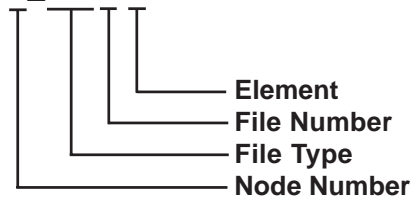



Device Data in a PLC is organized using Elements. Enter the device and address settings as follows.

• **When using Word Device**

(Display after entry)

1_INT7:0

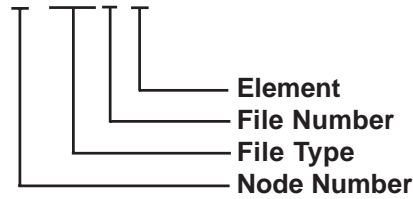

• **When using Bit Device**

(Display after entry)

1_BOOL0:10/3

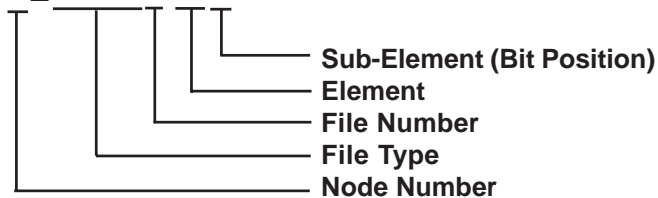

◆ Device Setting Example

The following explanation is for the ControlLogix 5000 device allocation.

1) PLC Tag Settings

Designate the Tag Name and Type.

- Tag Name : Can be set to any value. (Not related to GP device name)
- Type : Use one of the following data types for the Element setting.

(Use the same device name as the GP)

BOOL (32-bit data type)

INT (word data type)

DINT (dword data type)

SINT (byte data type)

REAL (float data type)

Example 1

Tag Name	Type
N7	INT[200]
DINT1	DINT[100]
DATA2	SINT[50]

This example’s data uses the following values.

- Row1 : Tag Name “N7” uses the INT data type for a 200 element array.
- Row2 : Tag Name “DINT1” uses the DINT data type for a 100 element array.
- Row3 : Tag Name “DATA2” uses the SINT data type for a 50 element array.

Be sure to set the number of array elements within the GP unit’s maximum usable range. (The GP can access up to 999 elements.)

Also, if array elements are not designated, only one element can be used.

Ex. Tag Name:N8, Type:INT allows only one word to be used by N8.

2) Mapping Settings

The tag name set in 1) can have any desired file number allocated to it. It is not possible to set the same file number to two tag names.

Example 2

File Number	Tag Number
2	DATA2
1	DINT1
7	N7

■ Control Logix 5000 Series Ethernet Protocol Limitation

Even though the Control Logix 5000 Series Ethernet Protocol can access more than one CPU, the following limitations apply.

1. Device Address and Node Number Limitations

When a different File Number or Node Number is set, the number of available device addresses will vary. The GP uses internal records to set the device addresses. These records are limited to 64. For example, when the N7:0 device address is set, a single record is used in the GP. For detailed examples, refer to the following chart.

Example 1 - Number of records used when designating tag setting numbers.

Setting No.	Device Address	Remaining Number of records in GP-PRO/PBIII	Remarks
1	INT7:0	63	Uses one record
2	INT9:0	62	Uses one record
3	BOOL10:0	61	Uses one record
4	BOOL11:0	60	Uses one record
5	INT7:255	60	Since the element number range already exists as setting No.1, no records will be used.
6	BOOL10:255	60	Since the element number range already exists as setting No.3, no records will be used.
7	INT12:0	59	Uses one record

When using a different File Number, GP internal records are used.

Example 2 - When setting tags from N10 to N19 (File Number), a total of 10 records will be used. Therefore, when setting tags continuously from N10 (File Number), File Numbers can be used up to N73.



When the number of records is over 65, the following error message will appear on the GP Screen Editor software (GP-PRO/PBIII for Windows).

“Address entry limit reached. No more addresses can be entered”

7.8.3

Environment Setup

■ GP Settings

The following screens show the GP's communication settings, which are required for communication via an Ethernet Network:

◆ SET UP OPERATION SURROUNDINGS MENU

<GP-477R/GP-577R/GP-2400/GP-2500/GP-2501/GP-2600/GLC2400/GLC2600 Series>

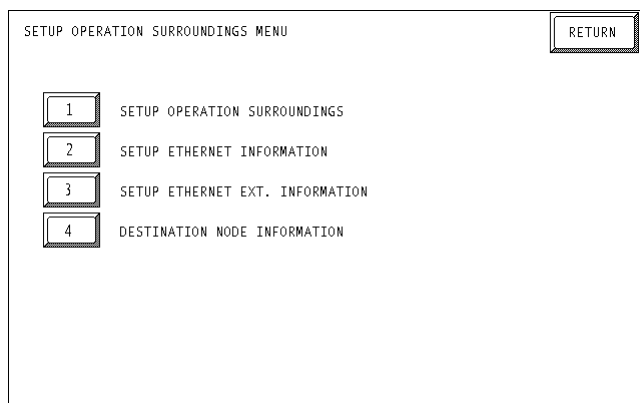

<GP-377R/GP-2300/GLC2300 Series>

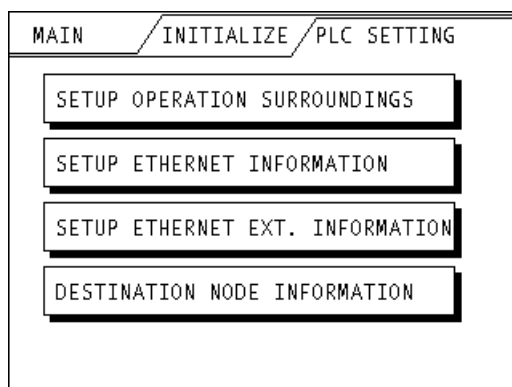

• **SET UP OPERATION SURROUNDINGS**

<<GP-477R/GP-577R/GP-2400/GP-2500/GP-2501/GP-2600/GLC2400/GLC2600Series>

SET UP OPERATION SURROUNDINGS		SET	CANCEL
STARTING ADDRESS OF SYSTEM DATA AREA	[]
SYSTEM AREA READING AREA SIZE (0-256)	[]
RESET GP ON DATA WRITE ERROR	ON	OFF	
<p>Note! The system start address cannot be changed on GP. Please use GP-PRO/PB3 to set this data and re-send to the GP.</p>			
	1	2	3
	4	5	6
	7	8	9
	0	↑	↓
		BS	
		←	→

<<GP-377R/GP-2300/GLC2300 Series>

SETUP OPERATION SURROUNDINGS	SET	ESC
SYSTEM AREA START ADR		
SYSTEM AREA READ SIZE		
RESET GP ON WRITE ERROR		
<p>Please use GP-PRO/PB3 to modify the system start address.</p>		



The System Area Start Address settings cannot be changed from the GP's OFFLINE mode. Be sure to make these settings from the GP Screen Editor's [GP SYSTEM SETUP] -> [MODE SETUP] setting area.



This manual, 7.8.3 Environment Setup ■GP-PRO/PBIII for Windows Settings

◆ **SETUP ETHERNET INFORMATION**

Enter each item in the SET UP ETHERNET INFORMATION screen.

<GP-477R/GP-577R/GP-2400/GP-2500/GP-2501/GP-2600/GLC2400/GLC2600 Series>

SETUP ETHERNET INFORMATION												SET	CANCEL	
SRC IP ADDRESS		[]	.	[]	.	[]	.	[]	.	[]				
SRC PORT NO.		[]												
	1	2	3	4	5	6	7	8	9	0		↑	↓	BS
												←	→	

<GP-377R/GP-2300/GLC2300 Series>

SETUP ETHERNET INFORMATION										SET	ESC
SRC IP ADD.		[]	.	[]	.	[]	.	[]	.	[]	
SRC PORT NO.											

- **SRC IP ADDRESS (0 to 255)**

Enter the IP address for your station’s GP unit. To do this, separate the 32 bits of the IP address into four segments of eight bits each, separate those segments with a dot and then enter them as decimal numbers.

- **SRC PORT NO. (1024 to 65535)**

Enter your GP’s Port No.



Do not specify duplicate IP addresses. Contact your network manager about assigning IP addresses.



- When using the built-in Ethernet port on a GP2000 Series unit, be sure not to enter duplicate "SRC PORT No." values.

Check the 2-Way driver's "SRC PORT No." Setting via the following menu:

GP OFFLINE mode's Main menu [INITIALIZE] -> [SETUP OPERATION SURROUNDINGS] -> [EXTENDED SETTINGS] -> [SETUP ETHERNET INFORMATION] screen.

The default value is 8000. The 2-Way driver uses this port and the following nine ports for a total of 10 (8000 ~ 8009).

When "SRC IP ADDRESS" is [0.0.0.0], the IP ADDRESS set in 2-Way Driver is enabled.

◆SET UP NETWORK EXT. INFORMATION

<GP-477R/GP-577R/GP-2400/GP-2500/GP-2501/GP-2600/GLC2400/GLC2600 Series>

SETUP ETHERNET EXT. INFORMATION		SET	CANCEL
SEND WAIT TIME	[] (ms)		
TIMEOUT	[] (x 2sec)		
IP ROUTER ADDRESS	[] . [] . [] . []		
SUBNET MASK	[] . [] . [] . []		
UDP RETRY COUNT(0-255)	[]		

	1	2	3	4	5	6	7	8	9	0			↑	↓	BS
													←	→	

<GP-377R/GP-2300/GLC2300 Series>

SETUP NETWORK EXT. INFORMATION	SET	ESC
SEND WAIT TIME	<input type="text"/>	(ms)
TIMEOUT	<input type="text"/>	(x 2sec)
IP ROUTER ADD.	[] . [] . [] . []	
SUBNET MASK	[] . [] . [] . []	
UDP RETRY COUNT(0-255)	<input type="text"/>	

- **SEND WAIT TIME (0 to 255)**

Wait time can be added when a command is transmitted from the GP. Use the wait time if the traffic on the communications line is heavy. If no wait time is required, enter “0.”

- **TIMEOUT (0 to 65535)**

Enter the desired timeout value. If no response is received from the other station within the specified time, a timeout occurs. If “0” is specified, the default time is 5 seconds with UDP/IP communication.

- **IP ROUTER ADDRESS**

Enter the IP address of the router (only one). If no router is used, enter “0” in all fields.

- **SUBNET MASK**

Enter the subnet mask settings. If no subnet mask is used, enter “0” in all fields.

- **UDP RETRY COUNT (0 to 255)**

This setting cannot be used and the setting value is disabled.



- ***If GP memory is initialized in OFFLINE mode, random values may be included. Download the GP System Setting data from GP-PRO/PBIII for Windows.***

◆ **When using SLC500 Series / Compact Logix units**

• **DESTINATION NODE INFORMATION**

<GP-477R/GP-577R/GP-2400/GP-2500/GP-2501/GP-2600/GLC2400/GLC2600 Series>

DESTINATION NODE INFORMATION		END
NODE	IP ADDRESS	
1	192.168.1.1	
2	192.168.1.2	
3	192.168.1.3	
Please use GP-PRO/PB3 to change them settings.		

<GP-377R/GP-2300/GLC2300 Series>

DESTINATION NODE INFORMATION		ESC
NODE	IP ADDRESS	
1	192.168.1.1	
2	192.168.1.2	
3	192.168.1.3	
Please use GP-PRO/PB3 to change them.		

• **DESTINATION NODE INFORMATION**

The Destination (PLC) Network Address, Destination Node Address and IP Address are displayed here.



The DESTINATION NODE INFORMATION cannot be set or changed from OFFLINE mode. Set or change these values from GP-PRO/PBIII for Windows [GP SYSTEM SETTINGS]-> [MODE SETTINGS] -> [NETWORK INFORMATION SETTINGS].

Reference This manual, 7.8.3 Environment Setup ■GP-PRO/PBIII for Windows Settings

◆ When using Control Logix 5000 Series unit

• DESTINATION NODE INFORMATION

<GP-2400/GP-2500/GP-2600/GLC2400/GLC2600 Series>

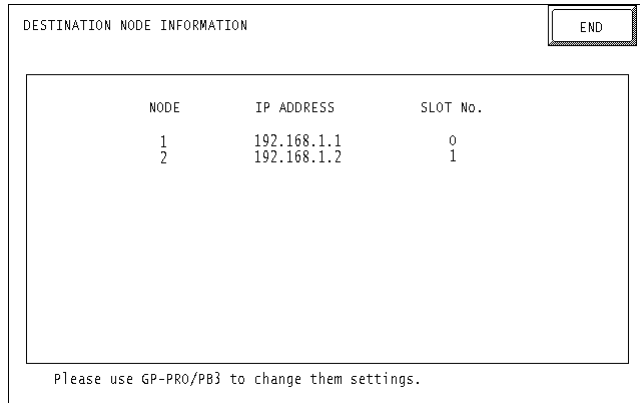

<GP-2300/GLC2300 Series>

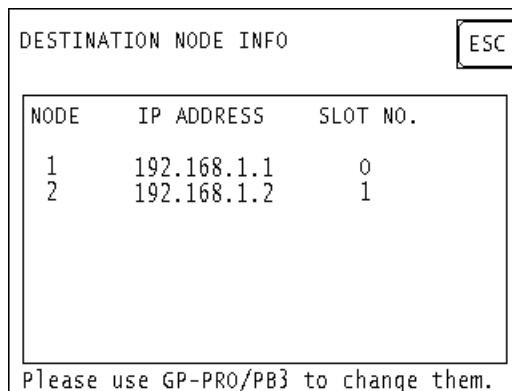

• DESTINATION NODE INFORMATION

Each PLC Node Number's IP Address and Slot No. are displayed here.



The DESTINATION NODE INFORMATION cannot be set or changed from OFFLINE mode. Set or change these values from GP-PRO/PBIII for Windows [GP SYSTEM SETTINGS]-> [MODE SETTINGS]-> [NETWORK INFORMATION SETTINGS].

*This manual, 7.8.3 Environment Setup ■GP-PRO/PBIII for
Reference Windows Settings*

■ **GP-PRO/PBIII for Windows settings**

The following items can be entered from GP-PRO/PBIII for Windows [GP SYSTEM SETTINGS] -> [MODE SETTING] area.

Menu	Sub Menu	Item
Communication Settings	_____	Source IP Address Source IP Port No.
	Advanced Communication Settings	Send Wait Time
		Time Out
		IP Router Address
		Subnet Mask
	UDP Retry Count	
Mode Settings	_____	System Start Address Read Area Size
	Network...	SLC500 Destination Node No. Destination Ip Address
		Control Logix 5000 Destination Node Information Destination Ip Address Slot Number

◆ **COMMUNICATION SETTINGS**

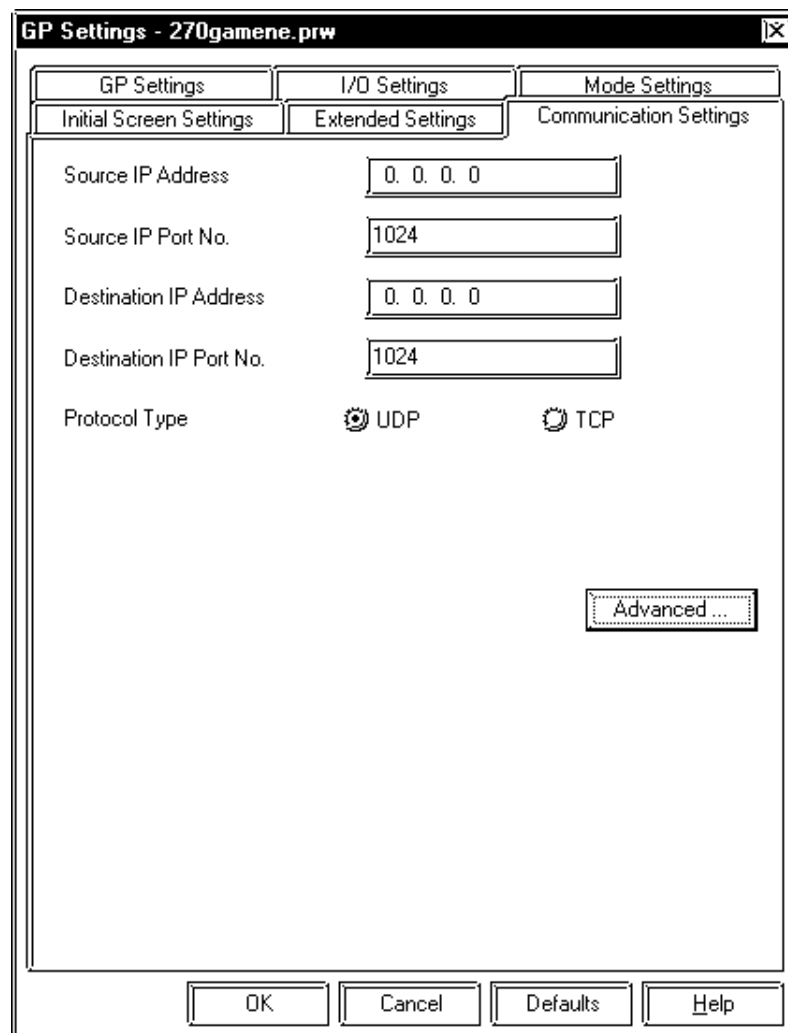

- **Source IP Address (0 to 255)**

Enter the IP address for your station’s GP unit. To do this, separate the 32 bits of the IP address into four segments of eight bits each, separate those segments with a dot and then enter them as decimal numbers.

- **Source IP Port No. (1024 to 65535)**

Enter the GP’s Port No.

- **Destination IP Address (0 to 255)**

This setting cannot be used.

- **Destination IP Port No. (1024 to 65535)**

This setting cannot be used.

- **Protocol Type**

This setting cannot be used.

- **ADVANCED COMMUNICATION SETTINGS**

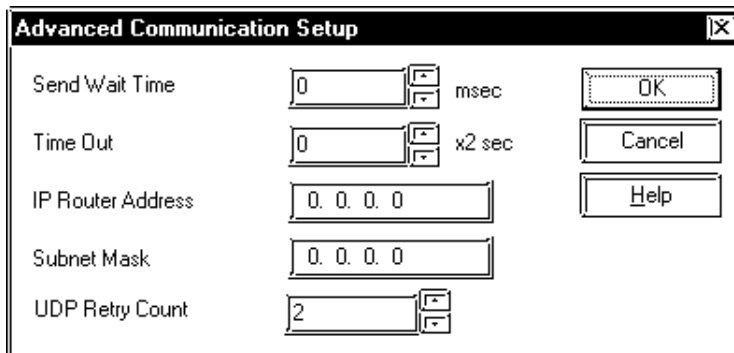

- **Send Wait Time (0 to 255)**

Wait time can be added when a command is transmitted from the GP. Use the wait time if the traffic on the communication line is heavy. If no wait time is required, enter “0.”

- **Time Out (0 to 65535)**

Enter the desired timeout value. If no response is received from the other station within the specified time, a timeout occurs. If “0” is specified, the default time is 5 seconds with UDP/IP communication.

- **IP Router Address**

Enter the IP address of the router (only one). If no router is used, enter “0” in all fields.

- **Subnet Mask**

Enter the subnet mask settings. If no subnet mask is used, enter “0” in all fields.

- **UDP Retry Count (0 to 255)**

This setting cannot be used.

◆ **MODE SETTINGS**

The screenshot shows the 'GP Settings - noname.tmp' dialog box with the 'Mode Settings' tab selected. The settings are as follows:

- PLC Type:** Allen Bradley SLC5/05(ETHER)
- System Start Address:** N7:0_1
- Machine Number:** 0
- Read Area Size:** 0
- Link Protocol Type:** 1:1
- Node Setup:**
 - Node Number:** 0
 - Transmission Status:** N7:0_1

Buttons at the bottom include OK, Cancel, Defaults, and Help. On the right side of the Node Setup section, there are 'Customize...' and 'Network...' buttons.

• **System Start Address**

The System Start Address is assigned to the PLC node designated here. For setting procedures, refer to 7.8.2 Supported Devices.

- **NETWORK INFORMATION SETTINGS**

Click the [Network...] button from [GP System Setting]-[Mode Setting] tab, and the Network Information window will appear.

Enter or edit the Destination Node Information.

When using an SLC500 Series unit

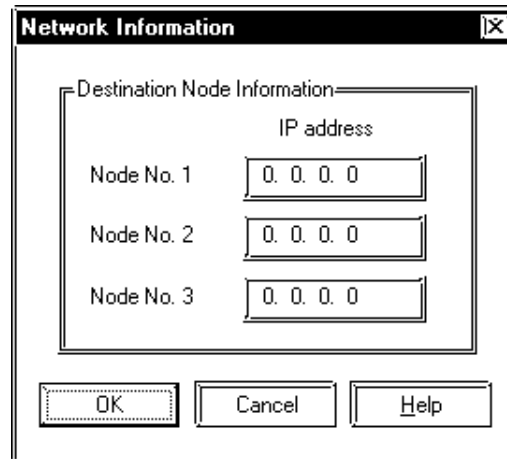

- **Destination Node Information**

Register IP Address to each destination PLC Node number. The Maximum number of Nodes is 3. The Destination Node IP Address needs to be set to the same address as the target PLC or the junction (intermediate) PLC's IP address.

When using an Control Logix 5000 Series / Compact Logix Series unit

The screenshot shows a dialog box titled "ControlLogix EtherNet/IP". It contains a "Target" section with the following fields:

- No. of node: 1 (dropdown menu)
- Node No.: 1 (dropdown menu)
- IP address: 0.0.0.0 (text input)
- Slot No.: 0 (text input)

At the bottom of the dialog are three buttons: "Ok", "Cancel", and "Help".

- **Target No. of node**

Designate the number of PLCs connected to one GP unit as either 1 or 2. If the number is 2, specify each Node Number and its corresponding IP Address. This Node Number is used when designating tag addresses.

- **Target Node No.**

Indicates the Node Number of the PLC designated by the IP Address.

- **Target IP address (0 to 255)**

Enter your PLC's IP address.

- **Target Slot No.**

Enter the PLC Slot No. used for installing the CPU unit.

■ PLC Setting

◆ SLC500 Series

GP Settings		PLC Settings	
Source IP Address	GP IP Address ^{*1}	-	-
Source Node Address	GP Port No. ^{*2}	-	-
Network Information Setting	Target PLC IP Address ^{*1}	IP Address	PLC IP Address

**1 Contact your network administrator about setting values.*

**2 When using the following function on a GP2000 Series unit, be sure not to use duplicate port number values. Check the 2-Way driver's port number setting via the following menu:*

From the GP OFFLINE mode's Main menu [INITIALIZE] -> [SETUP OPERATION SURROUNDINGS] -> [EXTENDED SETTINGS] -> [SETUP ETHERNET INFORMATION].

The default value is 8000. The 2-Way driver uses this port and the following nine ports for a total of 10 (8000 ~ 8009).



- **Protocol Type is TCP/IP Connection.**

◆ Control Logix 5000 Series / Compact Logix Series

GP Settings		PLC Settings	
IP Address	GP IP Address ^{*1}	—	—
Port No.	GP Port No. ^{*2}	—	—
Target IP Address	PLC IP Address ^{*1}	IP Address	PLC IP Address
Slot No. ^{*3}	PLC Slot No.	—	—

**1 Contact your network administrator about setting values.*

**2 When using the following function on a GP2000 Series unit, be sure not to use duplicate port number values. Check the 2-Way driver's port number setting via the following menu:*

From the GP OFFLINE mode's Main menu [INITIALIZE] -> [SETUP OPERATION SURROUNDINGS] -> [EXTENDED SETTINGS] -> [SETUP ETHERNET INFORMATION].

The default value is 8000. The 2-Way driver uses this port and the following nine ports for a total of 10 (8000 ~ 8009).

**3 It is not required to set Slot No. for Compact Logix series units. (Data transfer takes place regardless of what No. has been set)*



- **Protocol Type is TCP/IP Connection.**

7.8.4 Error Code

Reference *About the GP Ethernet Specific Error Codes, refer to the end of this Chapter, “Protocol Stack Error Codes”.*

■ PLC SPECIFIC ERROR CODES

◆ SLC500 Series

The PLC error codes are displayed by the “Host Communication Error (02:**:##)”, and are indicated in the left lower corner of the GP screen. (** indicates the PLC error codes. ## indicates the PLC node number.)

Error Code	Contents
10	The devices are not designated or the designated addresses are out of range.

Reference *For information about error codes, refer to Rockwell (Allen-Bradley)’s User Manual for SLC500 Series.*

◆ Control Logix 5000 Series / Compact Logix Series

The PLC error codes are displayed by the “Host Communication Error (02:**:##)” or “Host Communication Error (02:D0:##:○○:xxxx)”, and are indicated in the left lower corner of the GP screen. (** indicates the PLC error codes. ## indicates the PLC node number.) During data communication, the GP unit inserts 0xD0 to prevent the Local STS error code from overlapping with the Remote STS error code. When looking up PLC error codes in the manual, please note that error numbers larger than 0xD1 should be read after subtracting 0xD0.

Error code 0xD0 is CIP error code. ○○ indicates main error code, and xxxx indicates extended error codes.

E.g.1) GP Error Code		PLC Error Code
10	→	10 (Remote STS Error code)
D6	→	06 (EXT STS Error code)

Error Code	Contents
D6	The devices are not designated or the designated addresses are out of range.

E.g.2) D0:##:01:0318 -> 01(CIP main error code), 0318 (extended error codes)

01:0318	Link address to self is invalid. The designated slot number is incorrect.
01:0204	Unconnected message. May be displayed when the load on the PLC unit is high.
01:0301	No buffer memory. May be displayed when the load on the PLC unit is high.

Reference *For information about error codes, refer to Rockwell (Allen-Bradley)’s User Manual for SLC500 Series.*

7.9 Protocol Stack Error Codes

Protocol Stack Error Codes are displayed on the GP as follows.

Host communication error (02:FE:**)

** represents one of the following error codes, from 00 to F0.

Error Code	Description	Notes
00	There is a setup error related to the IP address of your station at initialization.	
05	Initialization has failed.	
06	Cancelling of communications has failed.	
07	An attempt was made to establish a connection before initialization was successfully completed.	
08	Your station's port number is incorrect	
09	The destination station's port number is incorrect.	
0A	The IP address of the other station is incorrect.	
0B	The same port number is already being used by UDP for establishing the connection.	
0C	The same port number is already being used by TCP for establishing the connection.	
0D	Protocol stack has refused connection establishment.	
0E	Protocol stack has returned the unsuccessful establishment of a connection.	
0F	The connection has been shut down.	
10	All connections are busy. No connection is available.	
13	Your station was aborted by a different station.	
30	There was no reply from the protocol stack.	
32	There was no reply from the other station.	*1*2
40	No network information exists for the designated node.	*1
41	I/O memory type of the random read-out response data is incorrect.	*1
42	Network information does not exist.	
F0	Undefined error.	

*1 When using an OMRON Corporation CS1/CJ/CJ1M Series unit, the error code will appear on the GP screen as shown below. Also, behind the Ethernet error code will appear the designated Network and Node addresses.

Host Communication Error (02:FE:**:###:###)

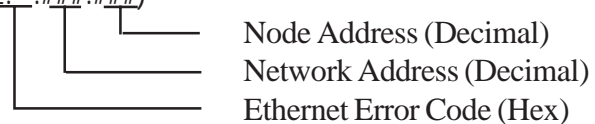

*2 When using a Hitachi Industrial Equipment Corporation's HIDIC H Series or a Schneider Corporation MODBUS TCP unit, the error code will appear on the GP screen as shown below. Also, behind the Ethernet error code will appear the designated Node address.

Host Communication Error (02:FE:**:###:###)

