

Ricoh KR-5 Super II

This camera manual library is for reference and historical purposes, all rights reserved.

This page is copyright by mike@butkus. M. Butkus, N.J.

This page may not be sold or distributed without the expressed permission of the producer

If you find this manual useful, how about a donation of \$3 to: M. Butkus, 29 Lake Ave., High Bridge, NJ 08829-1701 This will allow me to continue to buy new manuals and pay their shipping costs. It'll make you feel better, won't it?

If you use Pay Pal, use the link below. Use the above address for a check, M.O. or cash.

[Back to my main Chinon/Ricoh information page](#)



[BACK TO MAIN PAGE](#)

[Webmaster: The main difference with this camera and the KR-5 (1/500 shutter max) and KR-5 Super is the TTL wide open metering and the 1/2000 shutter]

Congratulations on your selecting of RICOH KR- 5 SUPER II. This is a compact and lightweight SLR camera with full open aperture TTL exposure metering. Enjoying good photography becomes far easier with this camera. It just requires releasing the shutter on your focused subject at the setting which the LED displays green. With carefully reading this booklet, you can enjoy easy-to-take highest quality photography for the years ahead.

DESCRIPTION OF PARTS

1. Shutter Speed Dial
2. Shutter Release Buttons
- 3 Film Advance Lever
4. Frame Counter
5. Strap Hook
6. Hand Grip
7. Self-timer Lever
- B. Lens Release Button
9. Hot Shoe
- 10 Film Rewind Crank

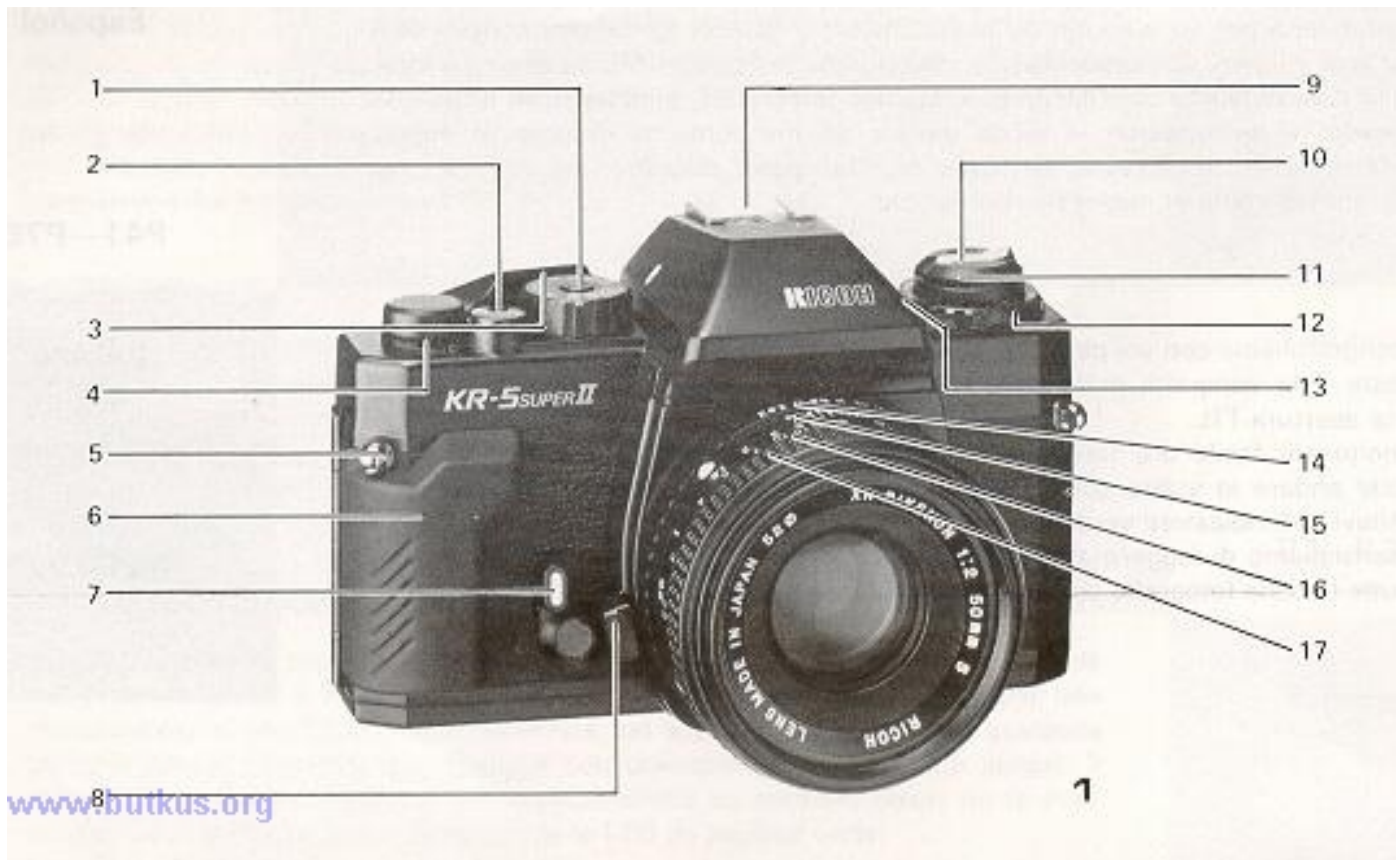

11. Film Rewind Knob/Film compartment Opening Knob

12. Film Speed Dial

13. Film Speed Index

14. Aperture Ring

15 Depth-of-field Scale (Not on all lenses)

16 Distance Scale

17 Focusing Ring

18. Viewfinder Eyepiece

19. Rewired Shaft

20. Film Chamber

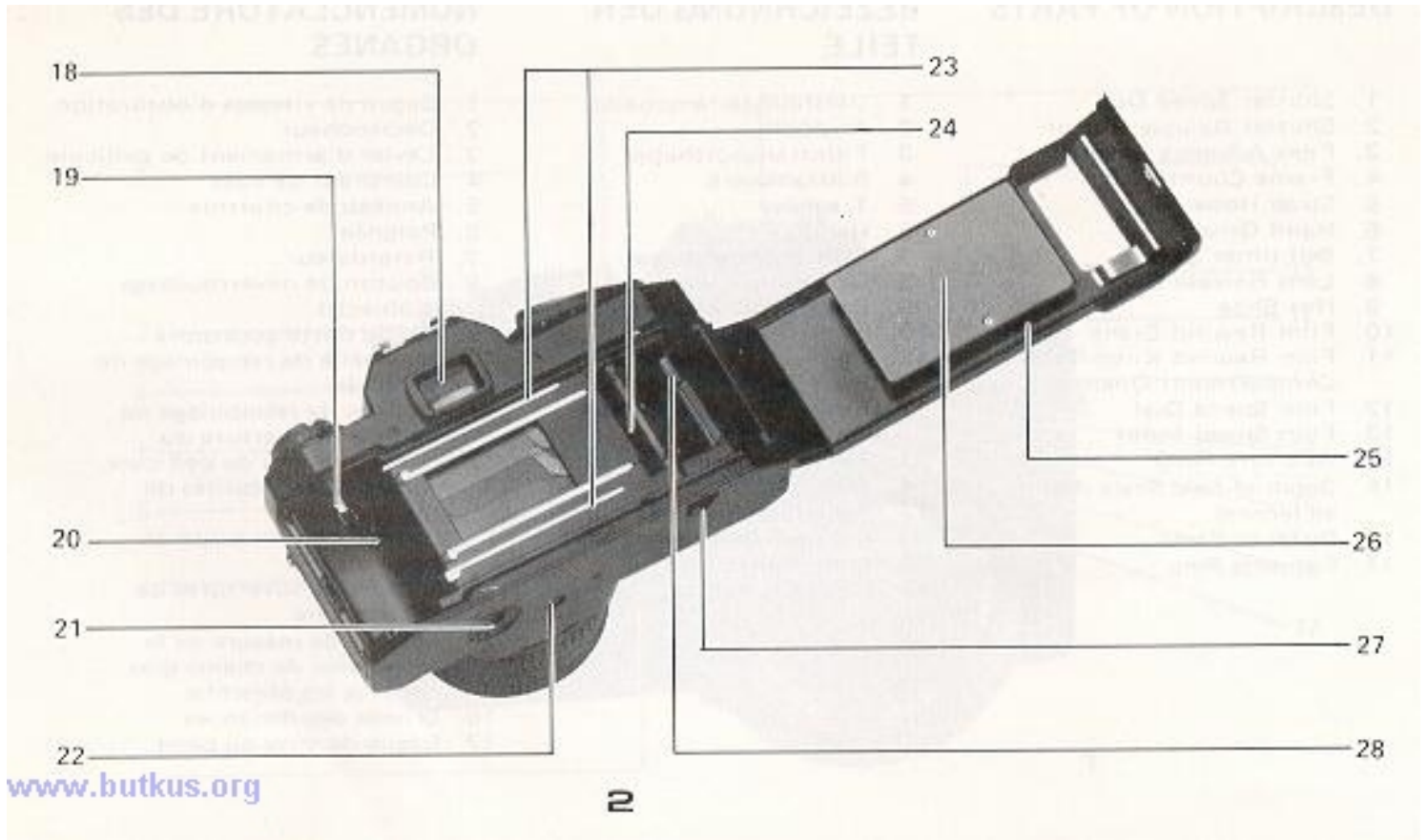

21. Battery Compartment Cover...

22. Tripod Socket

23 Film Guide Bars

24. Sprocket

25. Back Cover

26 Film Pressure Plate

27. film Rewind Button

28. Film Take up Spool

Inserting Batteries



1. Turn the battery compartment cover (21) counter clockwise using a coin or something similar.

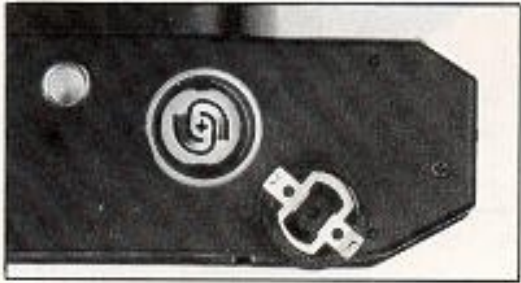

2. Two LR44 type alkaline batteries or two SR44 type silver batteries are used with this camera.

3 Place the batteries so that both positive (+) sides are at the top of the compartment



4. Turn the battery compartment cover clockwise until it closes firmly....

Battery Check

1. Move the film advance lever (3) to the ready position.

2. Partly press the shutter release button (2) Now the exposure metering system is switched on. Next, look through the viewfinder When one of three LED lamps (+, 0 or -) lights, then battery condition is satisfactory. If no lamp lights, the batteries need replacing or have been (loaded incorrectly).

3. Renew both batteries as necessary.

4. When not using of the camera, always return the film advance lever to the original position to prevent accidentally releasing the shutter.

Loading film

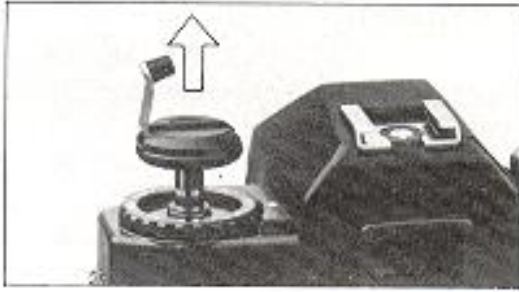

1. To open the back cover (25), fold out the film rewind crank (10), then pull knob (11) out. When the back cover opens, the frame counter (4) automatically resets to "S".

E

2. Insert the film cassette into the film chamber so that the projecting end of the film cassette is downward. Do this in a place away from direct sunlight.

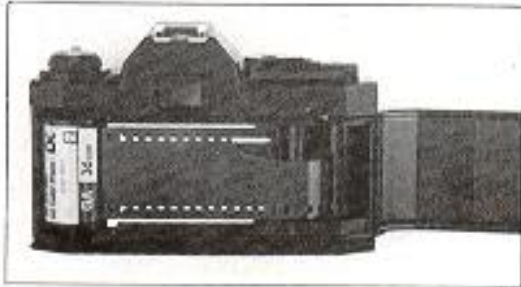

3. Fold out and lift up the film rewind crank (10) Then rotate the crank carefully while pushing it down lightly until the film locks on the film rewind shaft (19)_

7

4. Return the film rewind crank to its original position

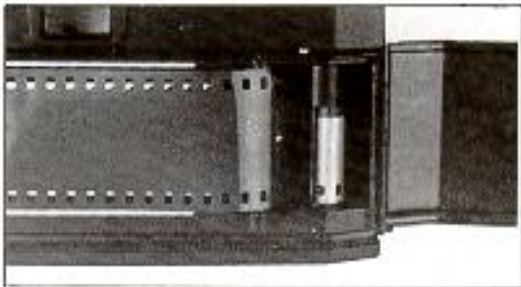

8

5. Insert the film leader into the groove of the take-up spool (28) and place it so that the film perforations engage with the spool teeth.

6. Check that the film perforations engage properly with the teeth of sprocket (24) and the film slides smoothly along the film guide bars (23) by operating lightly the film advance lever (3) to advance the film.

7. Turn the film rewind crank gently in the direction of the arrow to properly tension the loaded film, Stop turning the crank when it becomes stiff, and return the crank to its original position.

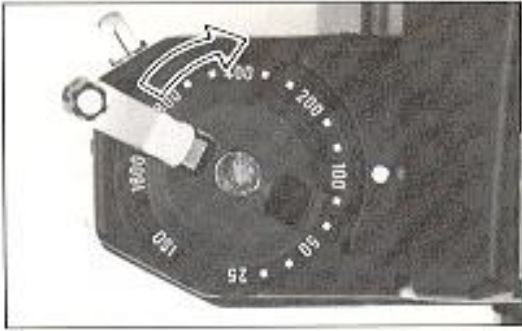

9

8. Close the back cover and push it until a click is heard....

9. Advance the film a couple of frames, pressing the shutter release button each time until the frame counter indicates "1" between 0 and 2. (In this case, the film advance lever should be at the ready position, because the shutter release is interlocked when the lever is in the stored position). The film rewind knob rotates each time the film is advanced meaning that the film is advancing properly.



10

Film speed Setting



11

1. Film speed is indicated on the outside of the film package or in the film instructions

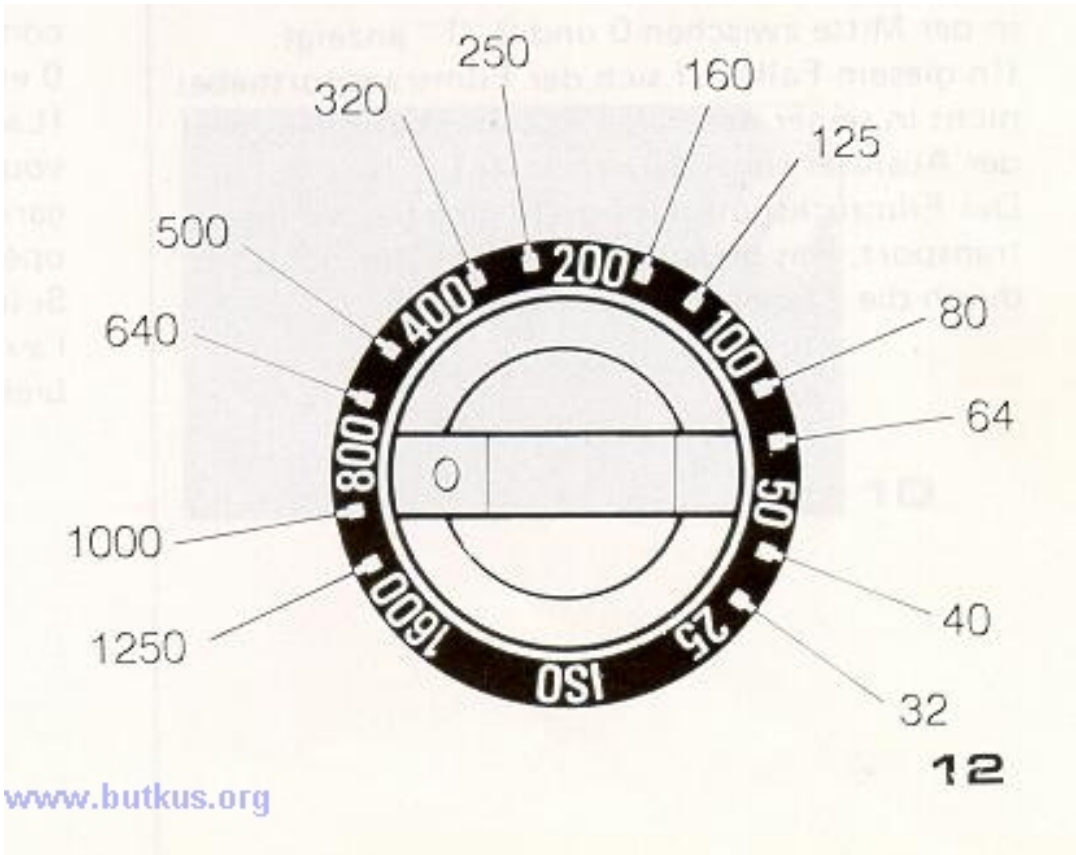

2. Set the film speed index (13) by turning the film speed dial (12) according to the value indicated by the film.

Exposure Setting (shutter speed priority)

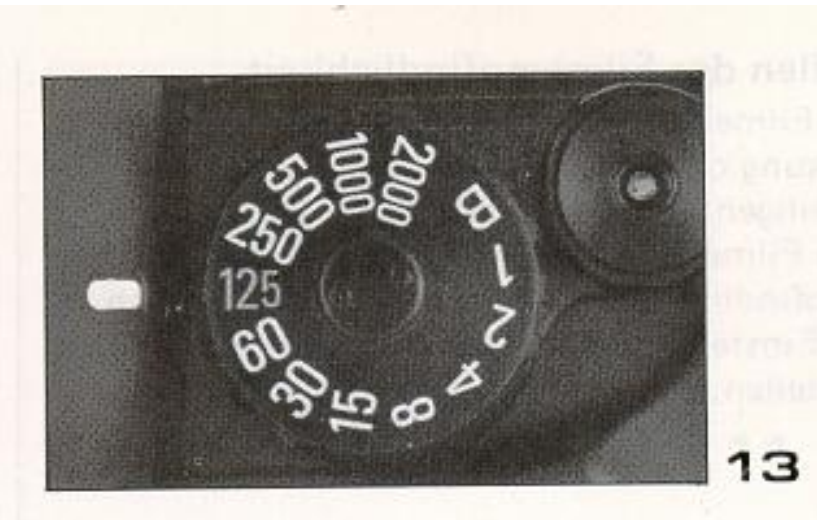

1. Place the film advance lever (3) in the ready position and turn the shutter speed dial so that the indicator white line aligns with the desired shutter speed value. If the dial is set at the intermediate positions of the index, shutter speed will be incorrect. Be sure that the dial clicks at the position where the white line aligns with the desired value. With setting at "B" (bulb) position, exposure monitoring is impossible.

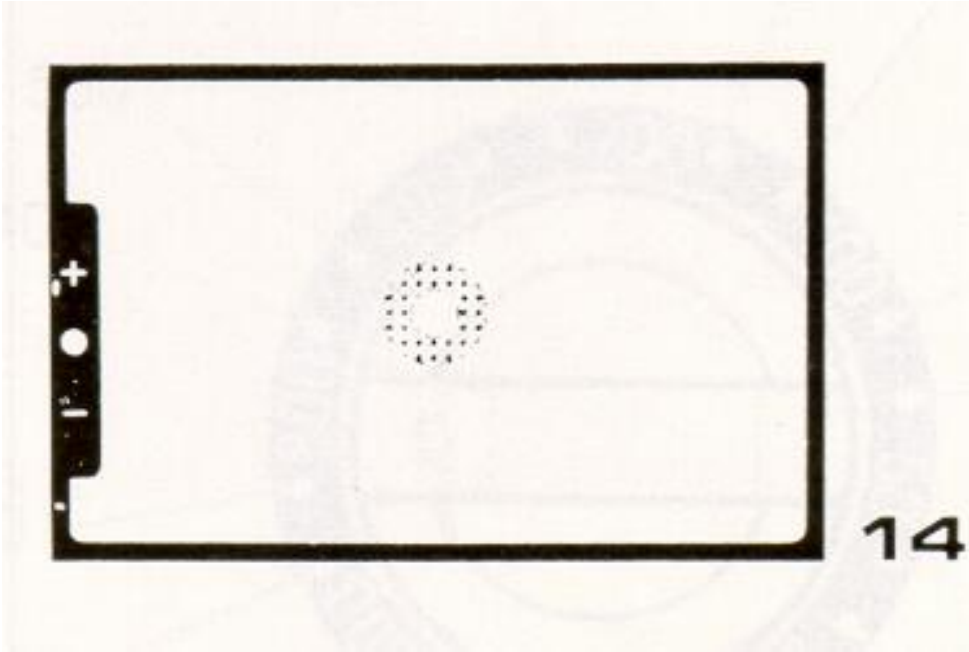

2. With brighter subjects, fast moving subjects or with the higher value film speed of the film used, it is recommended to use higher shutter speeds.

3. In photography using telephoto lenses, use the highest shutter; speed possible to avoid camera movement affecting your pictures. Generally selecting a higher shutter speed value than the focal length of the lens is recommended, i.e. 1/250 sec shutter speed is recommended for a telephoto lens with 135 mm focal length, and 1/500 see for 300 mm focal length.

4. Recommended shutter speed with ISO 100/21° film and standard 50mm focal length lens under typical situation is as follows:

Subject	Shutter speed
Stationary subjects	1 to 1/15
In subdued light	1 to 1/15
Indoors in normal conditions	1/30 to 1/60
Outdoors on a fine day	1/125 to 1/250
Seaside in midsummer	1/500 to 1/2000
mountain area with snow	1/500 to 1/2000
Fast moving subjects	1/500 to 1/2000

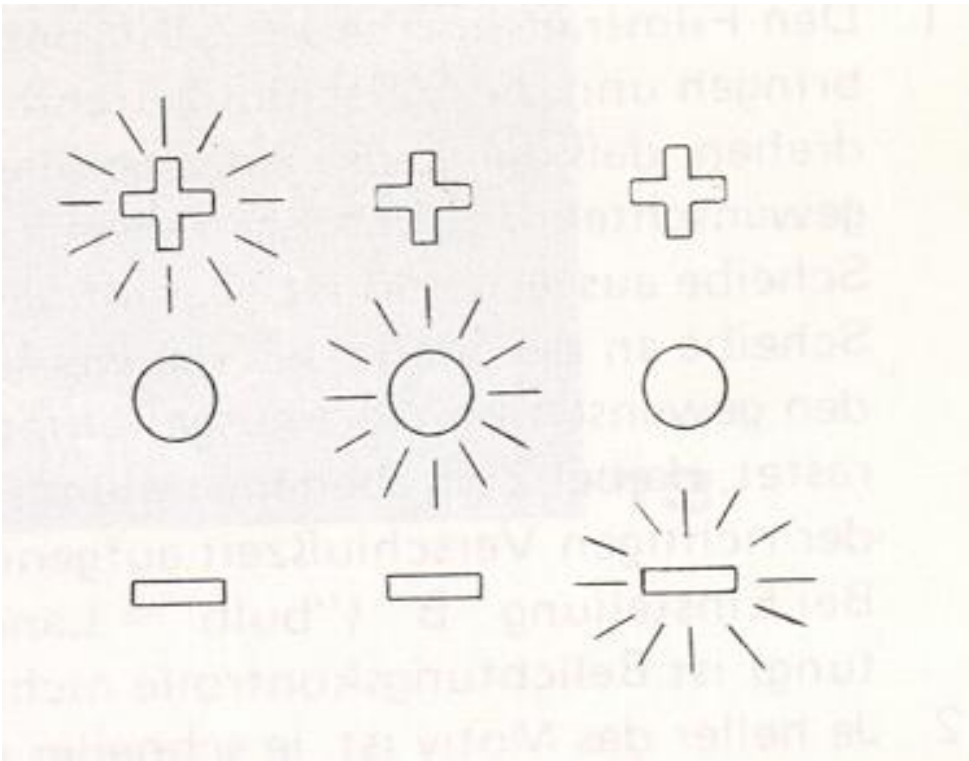

5. To monitor exposure, partly press the shutter release button (2), turn the aperture ring (14) until the green "0" mark lights in the viewfinder.

When the red mark (+) lights, meaning that the exposure is too great, turn the aperture ring in the direction to greater (higher number) F-stop. If the red (-) mark shows, exposure is below what is necessary, so turn the aperture ring (14) to a smaller (lower number) F-stop value....

Exposure setting (Aperture priority)

1. Place the film advance lever (3) in the ready position and turn the aperture ring (14) until the index on the lens barrel indicates the desired f/ value.

2. The suitable aperture

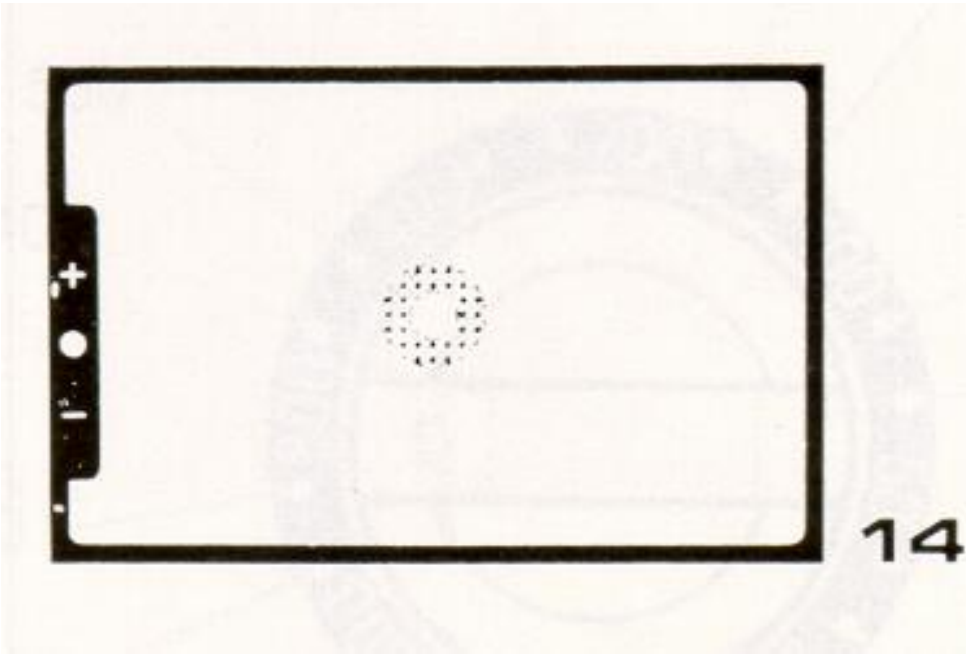

value changes according to the brightness of the subject, the depth-of-field desired or film speed of the film in use, and typical settings of the aperture with ISO 100/21° (ASA100/DIN21) film are as follows:

Subject	F-value
In subdued light	F/1.4 to F/2
To narrow depth of-field	F/1.4 to F/2
Indoors in normal condition	F/2 to F/4
Outdoors on a cloud day	F /4 to F /8
Outdoors on a fine day	F/8 to F/11
Seaside in midsummer	F/11 to F/16
Mountain areas with snow	F/11 to F/16

3. To monitor the exposure, partly press the shutter release button (2) and turn the shutter speed dial until the green (0) mark lights in the viewfinder. If the red (+) mark lights, turn the shutter speed dial to the higher shutter speed setting and if the red (-) mark lights, then turn the shutter speed dial to the lower setting. When the green (0) mark lights at intermediate positions between click, first set the dial at a click on either side and make fine control by operating the aperture ring afterwards.

Holding Camera

1. Hold the camera in the palm of the left hand so as to turn the (lens focusing ring (17) easily with fingers.

2. Hold the camera body lightly by holding grip (6) and place your right forefinger lightly on the shutter release button.

3. Press your left elbow lightly against you, body and look through the viewfinder eyepiece (18) to steady the camera against your face. Then relax your right arm holding the grip.

4. With telephoto lenses or lower shutter speeds, it is recommended to use a tripod and/or remote shutter release control cable.

Focusing

1. Focusing is done by observing through the circled area in the center of the viewfinder screen. Within the circle is the split image spot prism and around the circle there is the microprism collar.



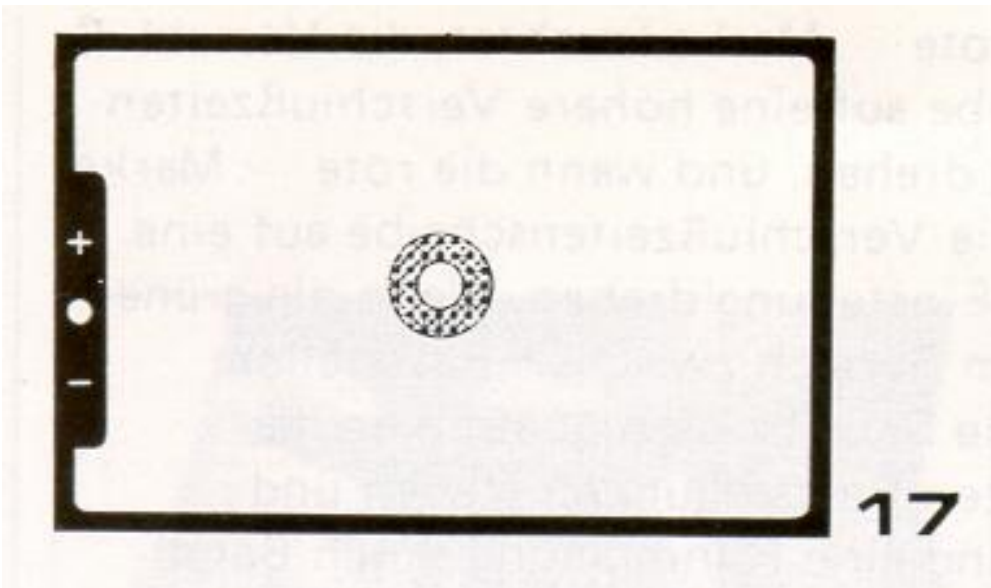

2. In focusing through the split image spot, when the image divided horizontally is brought into alignment by focusing, focus is correct. When the upper and lower half images do not align, it is out-of-focus.

3. To focus through the microprism collar outside center spot, a broken shimmering image is seen when it is out-of-focus and correct focus is at the setting in which the image becomes clear and sharp.

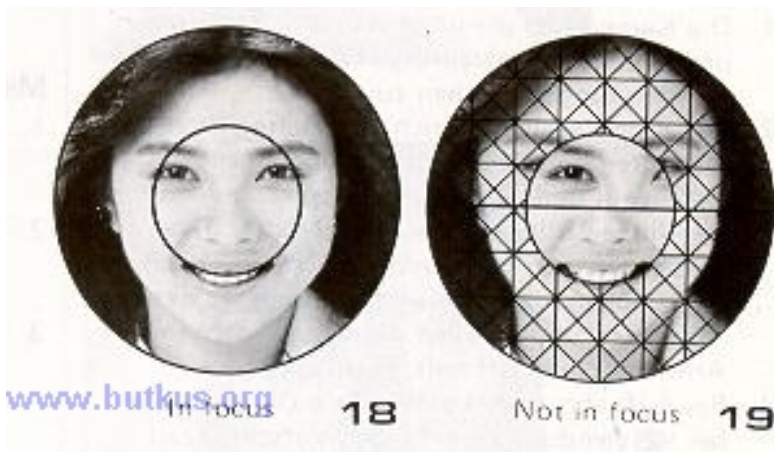

4. Focusing through the entire matte surface of the viewfinder is also possible. In this case, at the setting where the sharpest image is obtained, precise focusing is secured .

5. Choose the most effective focusing method from the above according to the shooting situation, such as the lens used, the subject, etc.

Rewinding the film

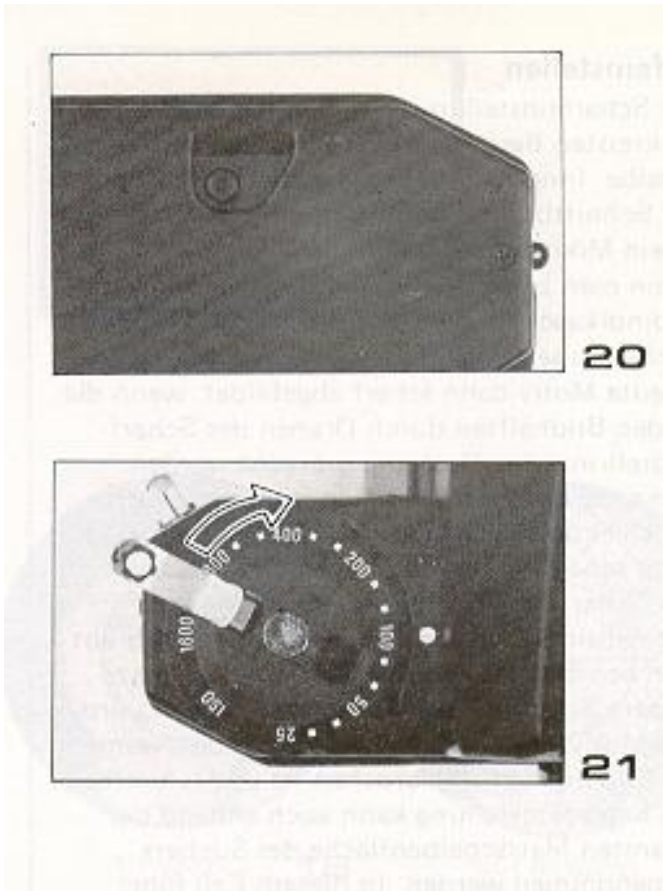

1. When the film advance lever no longer operates smoothly, check the frame counter (4) display. If the frame counter shows that the all frames of the loaded film have been exposed, replace the film.

2. Press the film rewind button (27) on the camera base.

3, Fold out the film rewind crank (10) and turn it in the direction of the arrow,

4. Once the pressure eases, the film is completely wound into the cassette.

5. Lift up the film rewind knob (11) and pull it out to open the back cover (25). Now the film cassette can be taken out....

6. Do this in a place away from direct sunlight,

"B" (bulb) Setting

1. With the shutter speed dial (1) set at "B" position, the shutter will remain open for as long as the shutter release button (2) is pressed. (Fig. 22)



22

2 This setting is useful when an exposure longer than one second is required, such as in landscape photography at night. Or it can be used for the special effect photography by employing the flash test button together with very dim light conditions



23

3. Be sure to use a tripod and/or remote shutter release control when using this shutter speed setting.

Self -Timer

1. Wind the film advance lever (3) and fully turn the self-timer lever (7) counter clockwise.

Now the self-timer is ready to use (fig. 23)

2. Press the shutter release button (2) and the self-timer operates to release the shutter in approximately 10 seconds later.

3. Once the self-timer becomes ready it is impossible to return it manually. So operate it only when you really need it.

4. The self-timer is very useful when you wish to include yourself in a picture, or, you can use it in order to prevent camera movement in shutter releasing instead of using the remote shutter release control.

Flash Photography

1. You only have to directly fit the flash unit in the hot-shoe (9).

2 Set the shutter speed dial (1) at 1/125 sec. or lower.

3. Set the corresponding aperture value from the Guide Number (G N.) of your flash unit by operating the aperture ring (14). For details on how to determine the correct aperture value to use, follow the instructions given in the manual of your flash unit. (Mike: If you have an Auto flash, place the flash in Auto and the flash should have an indicator as to what to set the F-stop on the lens to. This F-stop will be useful to the auto distances located on the flash.)

Depth-of -Field

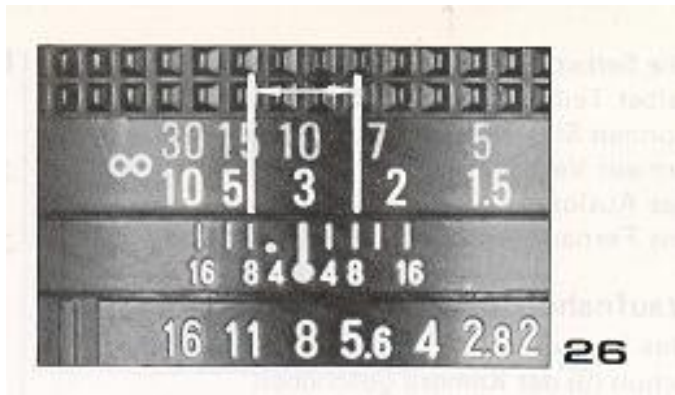

1. When you are focusing on a given subject, objects in the foreground and background will appear acceptably sharp in the picture. The range in which all objects appear acceptably sharp in the picture is called "depth-of-field."

2. To obtain the depth-of-field range at different aperture settings, the depth of-field scale (15)

is used. The depth-of-field scale is positioned between the focusing ring (17) and aperture

ring (14) The distance covered by the range between pairs of the same f/stops on the depth-of-field scale as the f/value used is the depth-of-field. To obtain the actual distance values of the depth-of-field, read the values within the range off the focusing scale

3. For instance, when the lens is focused on a subject at a distance of 3 m (9 8 ft.) with the aperture

set at f/8, the depth-of-field can be obtained by using the depth of field scale as follows the values

on the distance scale corresponding with the f/values shown on the depth-of-field scale are

approximately 2 4 m (7.9 ft.) and 4 5 m (14.8 ft.) respectively. This means that all objects within

the range between 2 4 m (7 9 ft) and 4.5 m (14 8 ft) distance can be reproduced acceptably

sharp in the picture with the aperture set at f/8....

Infrared Photography

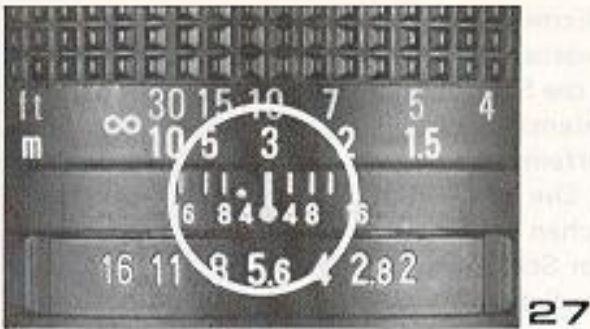

1. The dot mark engraved in red on the depth-of-field scale (15) is the infrared distance indicator. This is used for reading the distance scale in infrared photography using infrared film and filters. [Mike: this applies to Black and White IR films, color focuses as regular film.]



2. First, secure focus in the normal manner. Then, read off the subject distance on the normal distance scale (16), then align it with the infrared distance indicator.

3. For instance, when you focus on a subject at 3m in the normal manner, read off the value "3" on the focusing scale and move the focusing ring until the infrared distance indicator points to "3".

4. Always use the red filter when attempting infrared photography. For other details concerning infrared photography, follow the instructions of the infrared film used.

Mounting/Removing the Lens



1. The lens mounting of this camera is the "K" mount. All other lenses with a "K" mount can be mounted on this camera. [Mike: as with the other K-mount KR-5's you can use any type of K-mount lens.]

2. To mount the lens, after matching the red mark on the camera body with the red mark of the lens barrel, insert the lens in the camera body and turn the lens clockwise until it clicks.

3. To remove the lens from the camera body, turn the lens all the way counter clockwise while

keeping the lens release button (8) pressed, then lift it straight out of the mount.

SPECIFICATIONS

Type:	35mm SLR camera with focal plane shutter and TTL metering with 3 LED display, exposure setting obtained by matching "0" mark.
Film format:	24mm x 36mm
Mount type:	Bayonet "K" mount
Shutter release:	Metal focal plane shutter operating vertically - B to 1 - 1/2000 sec.
Flash Synchronization:	Hot-shoe, X contact, synchronized at 1/125 or lower shutter speed
Viewfinder:	Eye-level finder with use of pentaprism image magnification ratio on the finder 0.86x (with standard 50mm focal length lens at infinity) field-of-view 93°0 horizontally and vertically to the actual picture area. Focusing method; Matching the divided image through horizontal split image prism center spot, Focusing through microprism collar or entire matte surface is also possible
Displays in viewfinder:	red (+) mark LED overexposure warning; green " 0 ", mark LED good exposure indication, red (-) mark LED underexposure warning
Exposure metering:	Full aperture TTL metering system. Center weighted area measurement Display overexposure, underexposure warnings and good exposure indication Desired setting is obtain by matching " 0 " Mark, (zero method} Measurement range: ISO 100/21° EV5 (F2,1/8s) - EV19 (F16,1/2000s)
Film speed setting:	ISO 25/15° 1600/33, by 1/3 steps
Film advancing:	One frame advance by single-lever action with 135° throw and 30° stand-off Safety mechanism prevents double-frame advance or double exposure, shutter release button is interlocked with the advance lever stored at unused position
Film rewinding:	by operating the film rewind knob and film rewind crank, the button returns automatically to the original position at the completion of film winding
Frame counter:	Progressive type with auto reset by opening the back cover

Self Timer: Mechanical self-timer, approx. 10 sec duration

Power source: Two 1.5V alkaline batteries (LR44} or silver batteries (SR44) _

Size and weight:} 133 x 85 x 50mm, 410 9 (camera body only)