

PEAK650VL2B

Single Board Computer

User's Guide

@Copyright 2000

All Rights Reserved

Manual edition 1, October 2000

The information in this document is subject to change without prior notice in order to improve reliability, design and function and does not represent commitment on the part of the manufacturer.

In no event will the manufacturer be liable for direct, indirect, special, incidental, or consequential damages arising out of the use or the possibility of such damages.

This document contains proprietary information protected by copyright. All rights are reserved. No part of this manual may be reproduced by any mechanical, electronic, or other means in any form without prior written permission of the manufacturer.

Trademarks

PEAK 650 is registered trademarks of NEXCOM Co., Ltd., IBM PC is a registered trademark of International Business Machines Corporation. Intel and Pentium are registered trademarks of Intel Corporation. Award is a registered trademark of Award Software, Inc. Other product names mentioned herein are used for identification purposes only and may be trademarks and/or registered trademarks of their respective companies.

How to use this guide

This manual is written to help you use Peak 650. It describes how to arrange various settings on the Pentium CPU board to meet your requirements. It is briefed as follows:

Chapter 1, Introduction gives an overview of the product specifications. It also tells you what are included in the product package.

Chapter 2, Jumper Switches and Connectors describes the definitions and positions of Jumpers and Connectors that you may easily configure and set up per your requirement.

Chapter 3, Capability Expanding describes how to change or expand the CPU Board by changing the system memory and CPU to get more power out from the CPU board.

Chapter 4, Advanced BIOS Setup describes how to use the advanced PCI/Green BIOS to control almost every feature of the Peak 650.

The Appendix A describes how to set up the Watch Dog Timer (WDT) and gives an example to program the WDT.

Contents

CHAPTER 1 INTRODUCTION	1-1
1-1 SPECIFICATIONS.....	1-2
1-2 WHAT YOU'LL HAVE FROM THE PACKAGE	1-2
CHAPTER 2 SWITCHES AND CONNECTORS.....	2-1
2-1 MAIN BOARD LAYOUT	2-1
2-2 SWITCHES	2-2
2-3 CONNECTORS	2-3
CHAPTER 3 CAPABILITY EXPANDING.....	3-1
3-1 SYSTEM MEMORY	3-1
3-2 CHANGE CPU.....	3-2
CHAPTER 4 AWARD BIOS SETUP.....	4-1
4-1 BIOS SETUP.....	4-1
<i>Entering Setup</i>	4-1
<i>Control Keys</i>	4-2
<i>Getting Help</i>	4-3
<i>The Main Menu</i>	4-4
<i>Standard CMOS Features</i>	4-6
<i>Advanced BIOS Features Setup Menu</i>	4-9
<i>Advanced Chipset Features Setup Menu</i>	4-13
<i>Integrated Peripherals</i>	4-17
<i>Power Management Setup</i>	4-21
<i>PnP/PCI Configuration</i>	4-25
<i>PC Health Status</i>	4-27
<i>Frequency/Voltage Control</i>	4-28
<i>Supervisor/User Password Setting</i>	4-29
<i>Power-On Boot</i>	4-30
4-2 BIOS REFERENCE - POST MESSAGE	4-31
<i>POST Beep</i>	4-31
<i>Error Messages</i>	4-31
4-3 BIOS REFERENCE - POST CODES	4-35
APPENDIX	43
APPENDIX A WATCH DOG TIMER.....	43
<i>Watch Dog Timer Working Procedure</i>	43

	<i>Watch Dog Timer character and function</i>	43
	<i>Watch Dog Timer Control Register</i>	44
	<i>Watch Dog Timer Programming Procedure</i>	45
Appendix B	DVI Interface Pin Assignment	...
Appendix C	CON1: Digital Video Signals Interface (12 bit) ..	

Chapter 1 Introduction

Welcome to the PEAK 650 the most powerful Intel 815E based single board computer.

NEXCOM's PEAK 650 series combines the high performance and exceptional value of Intel Celeron / Pentium III CPU and 815E chipset with a full-featured, new generation, full-size single board computer. The Intel 815E chipset, which combining internal graphics, LAN, and support for 4 USB ports, Ultra DMA66/100 IDE interface, that meets the performance, stability and reliability requirements. Moreover, In order to meet the network requirement, the PEAK 650 series add one more Ethernet Controller Intel 82559 to support dual channel Ethernet.

For the Display solution, not only the Intel 82815 (GMCH) chipset integrated Graphics controller, PEAK 650 series also provide On Board Optional ATI Rage Mobility M4 3D VGA accelerator with on die 8MB or 16MB memory to support 4X AGP, which is compatible with DVI specification to support LCD panel.

The Intel 82815 (GMCH) chipset integrated Graphics with Intel Dynamic Video Memory Technology , the D.V.M.T. employs direct AGP and intelligent arbitration to dynamically allocate and de-allocate memory for textures for applications requiring additional texture memory. The operating system requires allocation of up to 1MB of system memory to support legacy VGA. System properties will display up to 1MB less than physical system memory available to the operating system. The graphics driver for the Intel 815 configuration will request up to 4MB of memory from the OS to implement a maximum 1024x768 screen resolution, 2MB for a command buffer and 4MB used for Z-buffering. For high-end 3D applications, the drivers request allocation of system memory from the O/S for AGP graphics textures. When the 3D application is closed, the O/S will re-allocate system memory back for generic use.

With the on board NEXCOM proprietary PCI Interface, the optional EBK SCSI 2 module design with Adaptec AIC-7890 Ultra 2 SCSI controller, and the module EBK SCSI 160D design with Adaptec AIC 7899 Dual Ultra 160 SCSI controller, giving the PEAK 650A a unique feature as a full function single board computer,

The board is suitable and valuable for all the embedded applications, which also well support with the Windows 2000, Windows NT and Linux Operation system.

1-1 Specifications

Product Feature

- Intel Socket 370 Celeron/Pentium III CPU running at 66/100/133MHz FSB up to 1GHz.
- Support SDRAM up to 512MB (Max.), with 100/133MHz SDRAM interface. Non Register Module.
- Dual Channel Ethernet by Intel 82801 (ICH2) chipset integrated LAN controller and Intel 82559 Ethernet Controller, support Alert-on-LAN.
- Intel 82815 (GMCH) chipset integrated Graphics controller.
- On Board Optional ATI Rage Mobility M4 3D VGA accelerator, support 4X AGP.
- ITE 8712 Enhanced Super I/O on board.
- On Board Nexcom proprietary PCI interface, Reserved 32bit PCI interface for EBK SCSI / EBK SCSI2 / EBK SCSI 160D module (Optional)
- On Chip enhanced IDE x 2, support Ultra DMA/66/100.
- On Chip Two USB controllers double the bandwidth to 24Mbps across four ports.
- ACPI Function Support
- Hardware Monitor for system Voltage and Temperature.
- On Board Solid State Disk Socket for DiskOnChip up to 288MB, and reserved Power header beside IDE connector to support DOM (DiskOnModule)
- ISAMAX Support, Maximize ISA signals to support ISA Card up to 20
- Full-size SBC with PCI and ISA golden Finger

Specification

- **System Architecture**

- Full size SBC with PCI/ISA Golden finger
- Intel Socket 370 Celeron/Pentium III with 66/100/133MHz FSB
- PCI V2.1 complied
- PICMG 1.0 (Rev.2.0) complied

- **CPU Support**

- Intel Brand New Socket 370 FC-PGA Celeron / Pentium III CPU with 128/256K cache on die, running at 66/100/133MHz FSB up to 1GHz
- Support streaming SIMD instruction

- **Main Memory**

- Support SDRAM up to 512MB (Max.), without ECC and Non-Register Mode SDRAM
- 168 pin DIMM socket x2
- Support 100/133MHz SDRAM interface
- Intel DVMT (Dynamic Video Memory Technology) offers a more efficient way to manage system memory, enabling software drivers, working in concert with the intelligent arbiter and the operating

system, utilize all of the system memory to support richer graphics applications.

- **BIOS**

- Award System BIOS
- Plug & Play support
- Advanced Power Management support
- Advanced Configuration & Power Interface support
- Jumperless for CPU FSB
- 2M bits flash ROM, upgradeable to 4M bits

- **Chip Set**

- Intel 815E chipsets
 - 82815 × 1 Graphics and Memory Controller Hub (GMCH)
 - 82801 × 1 I/O Controller Hub (ICH2)
 - 82802 × 1 Firmware Hub (FWH)
- ITE 8888F × 1 PCI to ISA Bridge

- **On Board VGA**

- Intel 82815 (GMCH) chipset integrated with Graphics controller
- Hardware motion compensation assist for software MPEG/DVD decode
- 15 pin CRT connector ×1

- **On Board optional VGA**

- ATI Rage Mobility M4 3D VGA accelerator. 4X AGP
- Fully PC 98 and PC 99 Compliant.
- Integrated 8MB of SDR Memory, upgradeable to 16MB
- 15 pin CRT connector ×1, DVI interface connector ×1

- **On Board LAN**

- Dual channel Ethernet support
- Intel 82801 (ICH2) chipset integrated LAN controller
- Intel 82559 Single Ethernet controller
- Alert-on-LAN by Intel 82801 (ICH2)
- 10 Base T/100 Base TX support, full duplex
- Complied with PCI V2.1, IEEE802.3, IEEE 802.3U
- Drivers support : DOS/Windows, Windows 95/98/2000, Windows NT4.0, Netware, SCO Open Server 5.0, Linux.
- RJ45 connector ×2

- **On Board Nexcom proprietary PCI interface**
 - Reserved 32bit PCI interface for EBK SCSI / EBK SCSI2 / EBK SCSI 160D module
- **On Board I/O**
 - ITE 8712 Enhanced Super I/O on board
 - SIO×2, with 2x16C550 UARTs, 10 pin header ×2, Optional RS422/485 ×1 for COM2
 - PIO×1, bi-directional, EPP/ECP support, 26 pin connector ×1
 - Floppy Disk controller : 5.25 360KB/1.2MB, 3.5 720KB/1.2MB/1.44MB/2.88MB support, 34 pin connector ×1
 - On chip enhanced IDE x 2, PIO up to mode 4, DMA master up to mode 2, Ultra DMA/66/100 support, 40 pin connector × 2, total 4 E.IDE devices support
 - On chip Keyboard, mouse controller, 5 pin connector x 1(for other keyboard) : 6 pin mini DIN connector ×1, for PS/2 keyboard/mouse
 - On board USB port ×4 (6pin header ×2)
 - On Board buzzer ×1
 - On board 2 pin header for I²C
 - On board 5 pin header for IrDA
 - On Board 2 pin header for reset SW, 4 pin for speaker, 5 pin for keylock, 2 pin power SW
- **ACPI Function**
 - Soft Power off
 - Wake On LAN
 - Wake On Keyboard
 - Wake On Ring
 - RTC alarm wake up
- **On Board Solid State Disk Socket**
 - On board reserved socket for DOC of M-systems : 2MB~288MB, etc
 - Power header beside IDE connector to support DOM
- **System Monitor**
 - Derived from Super IO ITE 8712 to support system monitor.
 - 7 voltage (For +3.3V, +5V, -5V , 5V STBY, +12V, -12V, and Vcore ×1)
 - One Fan speed (For CPU)
 - Two temperature
 - Drivers support : Windows 95/98, Windows NT4.0/2000
- **ISAMAX Support**
 - Maximize ISA signals to support ISA cards up to 20
- **Watchdog Timer**

- 1,2,4 4 seconds time-out intervals
- **Dimensions**
 - 340mm(L) × 122mm(W)
- **Power Requirements**
 - TBD for (Max. Typical)
- **Environments**
 - Operating temperatures : 0°C to 60°C
 - Storage temperatures : -20°C to 80°C
 - Relative humidity : 10% to 90% (Non-condensing)
- **Certification**
 - CE Verification
 - FCC Class A
- **Model Available**
 - PEAK 650VL2 -- Full-size Socket 370 Celeron/Pentium III CPU card w/VGA/Dual LAN
 - PEAK 650M8 –Full-size Socket 370 Celeron/Pentium III CPU card w/ATI M4 VGA w8MB /LANWhat you'll have from the package
 -

In addition to this manual, the PEAK 650 package includes the following items

Items	650VL2	650M8
PEAK 650 Board	1	1
Cable Set, include UDMA66 IDE Cable x 1; FDD Cable x1 ; Internal Keyboard Connector x1 ; COM and LPT Cable w/Bracket	1	1
Y CABLE PS/2 1 TO 2 KEYBOARD/MOUSE	1	1
ATX Power Cable connect SBC and BackPlane	1	1
Driver CD	1	1
PEAK 650 Quick Reference Guide Rev.A	1	1

If any of these items is missed or damaged, please contact your vendor for what you want

Chapter 2 Switches and Connectors

2-1 Main Board Layout

This chapter gives the definitions and shows where to locate the positions of switches and connectors.

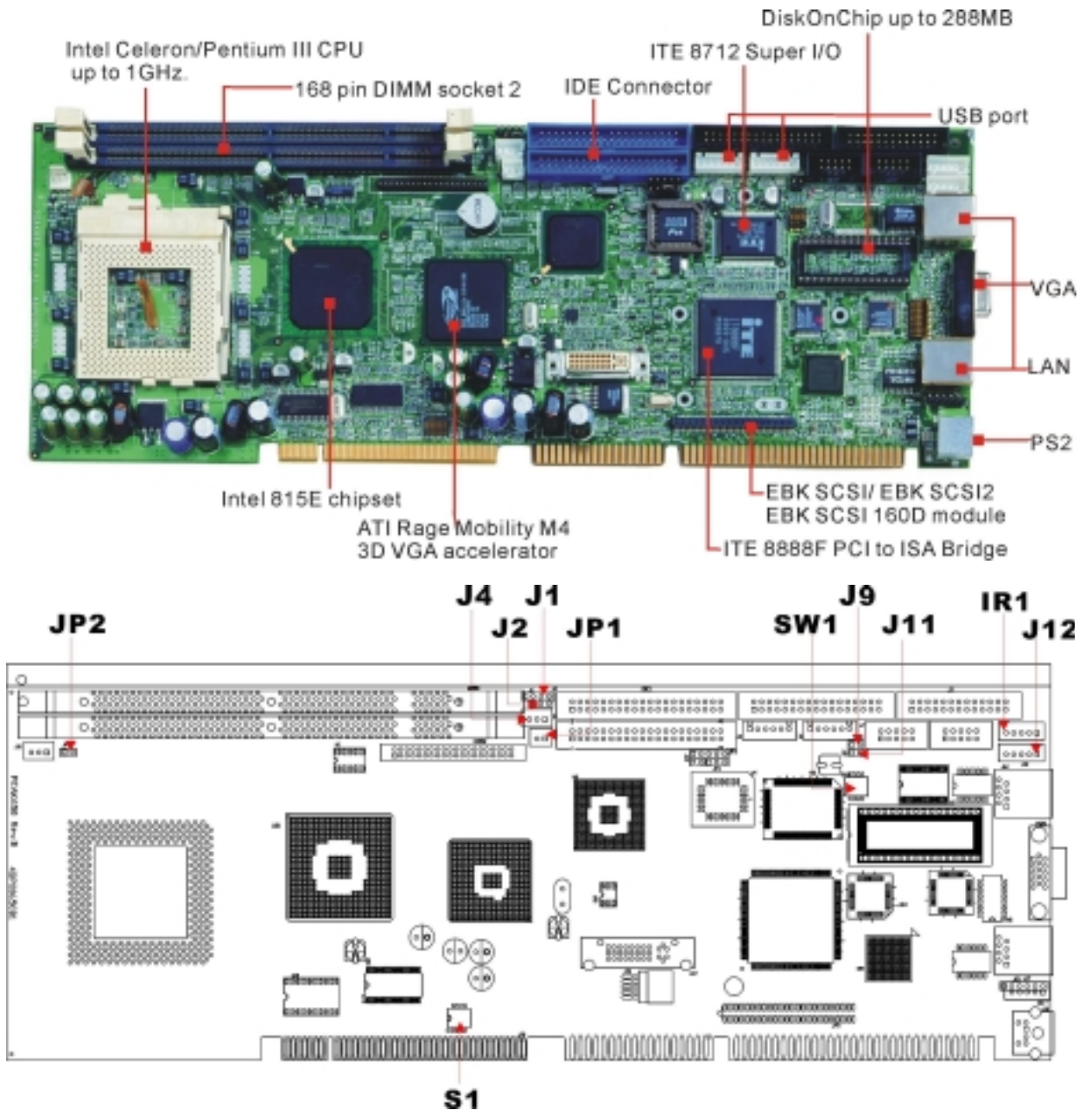

2-2 Switches

Switches on the CPU board are used to select options for different functions used. The switch-on or off is to accommodate the variations of the following table.

Switch Setting Table (*: default setup)

S1 (*: Default setting)

1	2	3	4	CPU FSB / Memory
ON	ON	OFF	OFF	* Auto detect
OFF	OFF	ON	ON	66MHZ / PC100 SDRAM
OFF	OFF	OFF	ON	100MHZ / PC100 SDRAM
OFF	OFF	ON	OFF	133MHZ / PC133 SDRAM
OFF	OFF	OFF	OFF	Reserve

SW2 (*: Default setting)

SW2	1	2	3	4	5	6	7	8	9	10
RS232 (*)	OFF	OFF	OFF	ON	OFF	ON	OFF	OFF	OFF	OFF
RS422	ON	ON	ON	OFF	ON	OFF	ON	ON	ON	ON
RS485	ON	ON	OFF	ON	ON	OFF	OFF	OFF	OFF	ON

SW1 (*: Default setting)

SW1/M-System	Disable (*)	C0000	C8000	D0000	D8000
1	OFF	ON	ON	ON	ON
2	X	ON	ON	OFF	OFF
3	X	ON	OFF	ON	OFF
4	X	X	X	X	X

2-3 Connectors

Jumper/Connector Define

J1: External speaker connector

Pin 1	Pin 2, 3	Pin4
Speaker signal	GND	VCC5

J2: Power supply type select:

Pin1-2 short	AT power
Pin2-3 short	ATX power

J4: 5VSB power cable connector

Pin 1	Pin 2	Pin3
5VSB	GND	ATX power supply S_ON"

Jp1: VCC5 power connector (for DOM)

Pin 1	Pin 2
VCC5	GND

Jp3: Keylock connector

Pin 1	Pin 3,5	Pin 4
VCC5	GND	keylock signal

J13: Reset button

Pin 1-2	Reset
---------	-------

JP4: CMOS set up

Pin 1-2	Pin 2-3
Normal	Clear CMOS

J9: Power On button (ATX)

Pin 1-2	Power on
---------	----------

J11: IDE LED connector

Pin 1	Pin 2
VCC5	IDE LED signal

IR1: IR connector

Pin 1	Pin 2	Pin 3	Pin 4	Pin 5
VCC5	NC	IR_RX	GND	IR_TX

J12: External keyboard connector

Pin 1	Pin 2	Pin 3	Pin 4	Pin 5
Keyboard CLK	Keyboard DAT	NC	GND5	VCC5

JP2: I2C connector

Pin 1	Pin2
SMB DAT	SMB CLK

J17: NEXCOM Reserved

Note: For Model Peak 650VL and Peak 650M8, the Nexcom plug in Module EBK SCSI2 or EBK SCSI160D cannot use Ad24 for IDSEL.

EBK SCSI 160D Jumper Setting**ON Board Active Terminal Resistor**

		Enable	Disable
Channel A	S1.1	OFF	ON
Channel B	S1.2	OFF	ON

IDSEL Jumper

AD20	JP1.1, JP1.2 Short
AD24	JP1.2, JP1.3 Short

SCSI LED Jumper

Channel A	LED+: JP2.1
	LED-: JP2.2
Channel B	LED+: JP2.3
	LED-: JP2.4

Chapter 3 Capability Expanding

This chapter explains how you can expand capability of your CPU board in such aspects as system memory and CPU.

3-1 System Memory

Peak650 support 2 slots for 168-pin 3.3V Non-registered DIMM modules, providing support for up to 512MB of main memory using DIMM modules from 8MB to 256MB. The following is the example to install the system SDRAM memory module combination.

Note:

1. It is highly recommended to use the PC-100 or PC-133 Specification DIMM module.
2. Due to limitation of Intel 815E chipset, the board can support the ECC memory module.

Quantity of Module	DIMM1	DIMM2	Module Size	Max. Size
1	1 st		8~256 MB	256 MB
2	1 st	2 nd	8~256 MB	512 MB

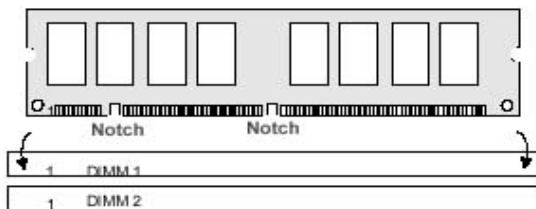

To insert the DIMMs, the modules must be oriented in the correct way. Notice the notches of the DIMM. Align these notches as shown in the diagram below. Gently push the DIMM until the retainers on both sides of the socket lock the module in place.

To remove a DIMM, push the retainers outwards to release the DIMM, then pull the module out of the socket.

3-2 Change CPU

To change the CPU, pull the handling bar of the socket upward to the other end to loosen the socket's openings. Carefully lift the existing CPU up to remove it from the socket.

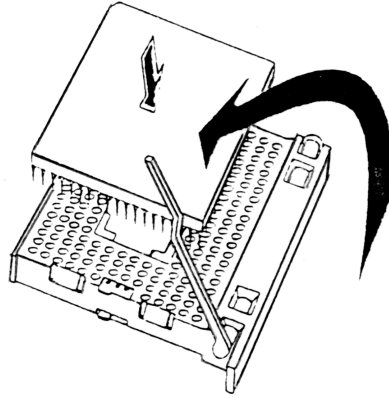

Removing CPU

Place the new CPU on the middle of the socket, orienting its beveled corner to line up with the socket's beveled corner. Make sure the pins of the CPU fit evenly to the socket openings. Replace the handling bar to fasten the CPU to the socket. Be sure to re-arrange the jumper setting for the correct external clock.

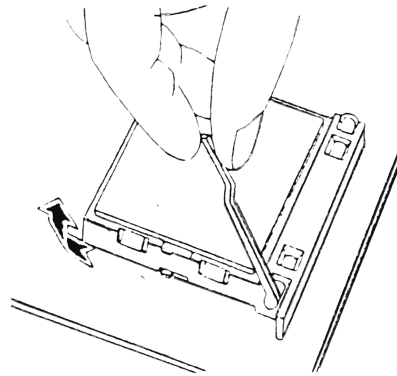

Installing CPU

Chapter 4 AWARD BIOS Setup

Award's BIOS ROM has a built-in Setup program that allows users to modify the basic system configuration. This type of information is stored in battery-backed RAM (CMOS RAM) so that it retains the Setup information when the power is turned off.

4-1 BIOS Setup

Entering Setup

Power on the computer and press **** immediately will allow you to enter Setup. The other way to enter Setup is to power on the computer, when the below message appears briefly at the bottom of the screen during the POST (Power On Self Test), press **** key or simultaneously press **<Ctrl>**, **<Alt>**, and **<Esc>** keys.

```
TO ENTER SETUP BEFORE BOOT
PRESS <CTRL-ALT-ESC> OR <DEL> KEY
```

If the message disappears before you respond and you still wish to enter Setup, restart the system to try again by turning it OFF then ON or pressing the "RESET" button on the system case. You may also restart by simultaneously pressing **<Ctrl>**, **<Alt>**, and **<Delete>** keys. If you do not press the keys at the correct time and the system does not boot, an error message will be displayed and you will again be asked to,

```
PRESS <F1> TO CONTINUE,
<CTRL-ALT-ESC> OR <DEL> TO ENTER SETUP
```

Control Keys























Up arrow		Move to previous item
Down arrow		Move to next item
Left arrow		Move to the item in the left hand
Right arrow		Move to the item in the right hand
Esc key		Main Menu -- Quit and not save changes into CMOS Status Page Setup Menu and Option Page Setup Menu -- Exit current page and return to Main Menu.
PgUp /  key	 / 	Increase the numeric value or make changes
PgDn /  key	 / 	Decrease the numeric value or make changes
F1 key		General help, only for Status Page Setup Menu and Option Page Setup Menu
(Shift)F2 key	 	Change color from total 16 colors. F2 to select color forward, (Shift) F2 to select color backward
F3 key		Reserved
F4 key		Reserved
F5 key		Restore the previous CMOS value from CMOS, only for Option Page Setup Menu
F6 key		Load the default CMOS value from BIOS default table, only for Option Page Setup Menu
F7 key		Load the Setup default value, only for Option Page Setup Menu
F8 key		Reserved
F9 key		Reserved
F10 key		Save all the CMOS changes, only for Main Menu

Table 4-1 Control Keys

Getting Help

Main Menu

The on-line description of the highlighted setup function is displayed at the bottom of the screen.

Status Page Setup Menu/Option Page Setup Menu

Press <F1> to pop up a small help window that describes the appropriate keys to use and the possible selections for the highlighted item. To exit the Help Window press <F1> or <Esc>.

The Main Menu

Once you enter Award BIOS CMOS Setup Utility, the Main Menu (Figure 1) will appear on the screen. The Main Menu allows you to select from ten setup functions and two exit choices. Use arrow keys to select among the items and press <Enter> to accept or enter the sub-menu.

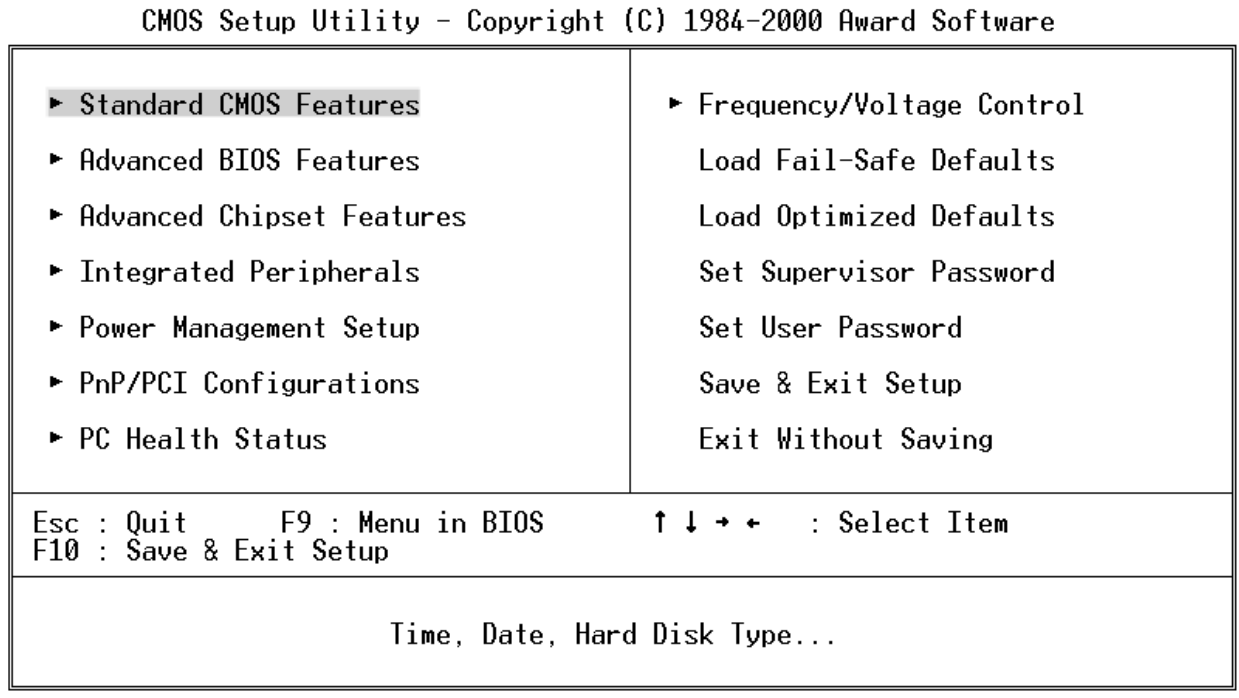

Standard CMOS Features

Use this menu for basic system configuration. See Page 4-6 for details.

Advanced BIOS Features

Use this menu to set the Advanced Features available on your system. See Page 4-9 for details.

Advanced Chipset features

Use this menu to change the values in the chipset registers and optimize your system's performance. See Page 4-13 for details.

Integrated Peripherals

Use this menu to specify your settings for integrated peripherals. See Page 4-17 for details.

Power Management setup

Use this menu to specify your settings for power management See Page 4-21 for details.

PnP/PCI Configuration

This entry appears if your system supports PnP / PCI Configuration. See Page 4-25 for details.

PC health Status

Display CPU/System Temperature, Fan speed and Voltages Value. See Page 4-27 for details.

Frequency/Voltage Control

Use this menu to specify your settings for frequency/voltage control. See Page 4-28 for details.

Load Fail-Safe Defaults

Use this menu to load the BIOS default values for the minimal/stable performance for your system to operate.

Load Optimized Defaults

Use this menu to load the BIOS default values that are factory settings for optimal performance system operations. While Award has designed the custom BIOS to maximize performance, the factory has the right to change these defaults to meet their needs.

Set Supervisor/User Password

Change, set, or disable password of supervisor or user. It allows you to limit access to the system and Setup, or just to Setup. See Page 4-29 for details.

Save & Exit Setup

Save CMOS value changes to CMOS and exit setup.

Exit Without Saving

Abandon all CMOS value changes and exit setup.

Standard CMOS Features

The items in Standard CMOS Setup Menu are divided into 11 categories. Each category includes no, one or more than one setup items. Use the arrow keys to highlight the item and then use the <PgUp> or <PgDn> keys to select the value you want in each item.

CMOS Setup Utility - Copyright (C) 1984-2000 Award Software Standard CMOS Features

Date (mm:dd:yy)	Wed, Oct 25 2000	Item Help
Time (hh:mm:ss)	17 : 49 : 3	
▶ IDE Primary Master		Menu Level ▶
▶ IDE Primary Slave		Change the day, month, year and century
▶ IDE Secondary Master		
▶ IDE Secondary Slave		
Drive A	1.44M, 3.5 in.	
Drive B	None	
Floppy 3 Mode Support	Disabled	
Video	EGA/VGA	
Halt On	All , But Keyboard	
Base Memory	640K	
Extended Memory	64384K	
Total Memory	65024K	

↑↓→←:Move Enter:Select +/-/PU/PD:Value F10:Save ESC:Exit F1:General Help
F5:Previous Values F6:Fail-Safe Defaults F7:Optimized Defaults

Main Menu Selections

Item	Options	Description
Date	MMM DD YYYY	Set the system date. Note that the week day automatically changes when you set the date
Time	HH : MM : SS	Set the system time
IDE Primary Master	Options are in its sub menu (Described in Table 4-3)	Press <Enter> to enter the sub menu of detailed options
IDE Primary Slave	Options are in its sub menu (Described in Table 4-3)	Press <Enter> to enter the sub menu of detailed options
IDE Secondary Master	Options are in its sub menu (Described in Table 4-3)	Press <Enter> to enter the sub menu of detailed options
IDE Secondary Slave	Options are in its sub menu (Described in Table 4-3)	Press <Enter> to enter the sub menu of detailed options
Drive A	None	Select the type of floppy disk drive installed in your system

Drive B	360K, 5.25 in 1.2M, 5.25 in 720K, 3.5 in 1.44M, 3.5 in 2.88M, 3.5 in	
Floppy 3 Mode	Disabled, Drive A, Drive B, Both	3 Mode floppy disk drives (FDD) are 3 1/2" drives used in Japanese computer systems. If you need to access data stored in this kind of floppy, you must select this mode, and of course you must have a 3 Mode floppy drive.
LCD&CRT	LCD CRT AUTO LCD&CRT	Select the default video device
Halt On	All Errors No Errors All, but Keyboard All, but Diskette All, but Disk/Key	Select the situation in which you want the BIOS to stop the POST process and notify you
Base Memory	N/A	Displays the amount of conventional memory detected during boot up
Extended Memory	N/A	Displays the amount of extended memory detected during boot up
Total Memory	N/A	Displays the total memory available in the system

Table 4-2 Main Menu Selections

IDE Adapters

The IDE adapters control the hard disk drive. Use a separate sub menu to configure each hard disk drive.

Use the legend keys to navigate through this menu and exit to the main menu. Use below table to configure the hard disk.

Item	Options	Description
IDE HDD Auto-detection	Press Enter	Press Enter to auto-detect the HDD on this channel. If detection is successful, it fills the remaining fields on this menu.
IDE Primary Master	None Auto Manual	Selecting <code>anual</code> lets you set the remaining fields on this screen. Selects the type of fixed disk. "User Type" will let you select the number of cylinders, heads, etc. Note: PRECOMP=65535 means NONE !
Capacity	Auto Display your disk drive size	Disk drive capacity (Approximated). Note that this size is usually slightly greater than the size of a formatted disk given by a disk checking program.
Access Mode	Normal LBA Large Auto	Choose the access mode for this hard disk
The following options are selectable only if the IDE Primary Master item is set to <code>anual</code>'		
Cylinder	Min = 0 Max = 65535	Set the number of cylinders for this hard disk.
Head	Min = 0 Max = 255	Set the number of read/write heads
Precomp	Min = 0 Max = 65535	**** Warning: Setting a value of 65535 means no hard disk
Landing zone	Min = 0 Max = 65535	****
Sector	Min = 0 Max = 255	Number of sectors per track

Table 4-3 Hard disk selections

Advanced BIOS Features Setup Menu

This section allows you to configure your system for basic operation. You have the opportunity to select the system default speed, boot-up sequence, keyboard operation, shadowing and security.

CMOS Setup Utility - Copyright (C) 1984-2000 Award Software
Advanced BIOS Features

Virus Warning	Disabled	▲ ▼	Item Help
CPU Internal Cache	Enabled		Menu Level ▶
External Cache	Enabled		Allows you to choose the VIRUS warning feature for IDE Hard Disk boot sector protection. If this function is enabled and someone attempt to write data into this area , BIOS will show a warning message on
CPU L2 Cache ECC Checking	Enabled		
Processor Number Feature	Enabled		
Quick Power On Self Test	Disabled		
First Boot Device	Floppy		
Second Boot Device	HDD-0		
Third Boot Device	LS120		
Boot Other Device	Enabled		
Swap Floppy Drive	Disabled		
Boot Up Floppy Seek	Enabled		
Boot Up NumLock Status	Off		
Gate A20 Option	Fast		
Typematic Rate Setting	Enabled		
Typematic Rate (Chars/Sec)	30		
Typematic Delay (Msec)	250		
Security Option	Setup		
OS Select For DRAM > 64MB	Non-OS2		
HDD S.M.A.R.T. Capability	Disabled		

↑↓←→:Move Enter:Select +/-/PU/PD:Value F10:Save ESC:Exit F1:General Help
F5:Previous Values F6:Fail-Safe Defaults F7:Optimized Defaults

Virus Warning

Allows you to choose the VIRUS Warning feature for IDE Hard Disk boot sector protection. If this function is enabled and someone attempt to write data into this area, BIOS will show a warning message on screen and alarm beep.

Enabled	Activates automatically when the system boots up causing a warning message to appear when anything attempts to access the boot sector or hard disk partition table.
Disabled	No warning message will appear when anything attempts to access the boot sector or hard disk partition table.

! WARNING!
Disk boot sector is to be modified
Type "Y" to accept write or "N" to abort write
Award Software, Inc.

Note: This function is available only for DOS and other OSes that do not trap INT13.

CPU Internal Cache/External Cache

These two categories speed up memory access. However, it depends on CPU/chipset design. The default value is Enable. If your CPU without Internal Cache then this item PU Internal Cache will not be show.

The Choice: Enabled/Disabled

CPU L2 Cache ECC Checking

This category could turn on the ECC of Pentium III L2 Cache or just disable it.

The Choice: Enabled/Disabled

Processor Number Feature

Intel included a serial number in their Pentium III processors as a unique system identifier. For privacy reasons, you can disable this setting to prevent the release of this identifier.

The Choice: Enabled/Disabled

Quick Power On Self Test

This category speeds up Power On Self Test (POST) after you power on the computer. If it is set to Enable, BIOS will shorten or skip some check items during POST.

The Choice: Enabled/Disabled

First / Second / Third Boot Device

The BIOS attempts to load the operating system from the devices in the sequence selected in these items.

The Choice: Floppy, LS/ZIP, HDD, SCSI, CDROM, Disabled.

Boot Other Device

If all the selected boot devices failed to boot, select **Enabled** the BIOS will try to boot from the other boot devices (in a predefined sequence) which are present but not selected as boot devices in the setup (and hence have not yet been tried for booting). If select **Disabled**, that may be present but not selected as boot devices in setup.

Swap Floppy drive

If the system has two floppy drives, you can swap the logical drive name assignments.

The choice: Enabled/Disabled.

Boot Up Floppy Seek

Seeks disk drives during boot up. Disabling speeds boot up.

The Choice: Enabled/Disabled.

Boot Up NumLock Status

Select power on state for NumLock.

The Choice: Enabled/Disabled.

Gate A20 Option

Select if chipset or keyboard controller should control GateA20.

Normal	A pin in the keyboard controller controls GateA20
Fast	Lets chipset control Gate A20

Typematic Rate Setting

Key strokes repeat at a rate determined by the keyboard controller. When enabled, the typematic rate and typematic delay can be selected.

The Choice: Enabled/Disabled.

Typematic Rate (Chars/Sec)

Sets the number of times a second to repeat a key stroke when you hold the key down.

The Choice: 6, 8, 10, 12, 15, 20, 24, 30

Typematic Delay (Msec)

Sets the delay time after the key is held down before it begins to repeat the keystroke.

The Choice: 250, 500, 750, 1000.

Security Option

Select whether the password is required every time the system boots or only when you enter setup.

System	The system will not boot and access to Setup will be denied if the correct password is not entered at the prompt.
Setup	The system will boot, but access to Setup will be denied if the correct password is not entered at the prompt.

Note: To disable security, select PASSWORD SETTING at Main Menu and then you will be asked to enter password. Do not type anything and just press <Enter>, it will disable security. Once the security is disabled, the system will boot and you can enter Setup freely.

MPS Version control For OS

This field specifies the version of MPS used by the motherboard.

The Choice: 1.1, 1.4

OS Select for DRAM > 64MB

Select the operating system that is running with greater than 64MB of RAM on the system.

The Choice: Non-OS2, OS2

HDD S.M.A.R.T. Capability

S.M.A.R.T. (Self-Monitoring, Analysis and Reporting Technology) is a technology developed to manage the reliability of the hard disk by predicting future device failures. The hard disk needs to be S.M.A.R.T. capable. The settings for this option are Disabled or Enabled.

* Note: S.M.A.R.T. cannot predict all future device failures. S.M.A.R.T. should be used as a warning tool, not as a tool to predict the device reliability.

The Choice: Enabled/Disabled.

Advanced Chipset Features Setup Menu

Since the features in this section are related to the chipset in the CPU board and all are optimized, you are not recommended to change the default settings in the setup table, unless you know very detailed of the chipset features.

CMOS Setup Utility - Copyright (C) 1984-2000 Award Software Advanced Chipset Features

SDRAM CAS Latency Time	3	▲ ▼	Item Help
SDRAM Cycle Time Tras/Trc	7/9		Menu Level ▶
SDRAM RAS-to-CAS Delay	3		
SDRAM RAS Precharge Time	3		
System BIOS Cacheable	Enabled		
Video BIOS Cacheable	Enabled		
Memory Hole At 15M-16M	Disabled		
CPU Latency Timer	Enabled		
Delayed Transaction	Enabled		
AGP Graphics Aperture Size	64MB		
Display Cache Frequency	100 MHz		
System Memory Frequency	Auto		
Power-Supply Type	AT		
On-Chip Video Window Size	64MB		
* Onboard Display Cache Setting *			
CAS# Latency	3		
Paging Mode Control	Open		
RAS-to-CAS Override	by CAS# LT		
RAS# Timing	Fast		
RAS# Precharge Timing	Fast		

↑↓→←:Move Enter:Select +/-/PU/PD:Value F10:Save ESC:Exit F1:General Help
F5:Previous Values F6:Fail-Safe Defaults F7:Optimized Defaults

This section allows you to configure the system based on the specific features of the installed chipset. This chipset manages bus speeds and access to system memory resources, such as DRAM and the external cache. It also coordinates communications between the conventional ISA bus and the PCI bus. It must be stated that these items should never need to be altered. The default settings have been chosen because they provide the best operating conditions for your system. The only time you might consider making any changes would be if you discovered that data was being lost while using your system.

The first chipset settings deal with CPU access to dynamic random access memory (DRAM). The default timings have been carefully chosen and should only be altered if data is being lost. Such a scenario might well occur if your system had mixed speed DRAM chips installed so that greater delays may be required to preserve the integrity of the data held in the slower memory chips.

SDRAM CAS Latency Time

When synchronous DRAM is installed, the number of clock cycles of CAS latency depends on the DRAM timing.

The Choice: 2, 3

SDRAM Cycle Time Tras/Trc

Select the number of SCLKs for an access cycle.

The Choice: 5/7, 7/9.

SDRAM RAS-to-CAS Delay

This field let you insert a timing delay between the CAS and RAS strobe signals, used when DRAM is written to, read from, or refreshed. Fast gives faster performance; and Slow gives more stable performance. This field applies only when synchronous DRAM is installed in the system.

The Choice: 2, 3.

SDRAM RAS Precharge Time

If an insufficient number of cycles is allowed for the RAS to accumulate its charge before DRAM refresh, the refresh may be incomplete and the DRAM may fail to retain data. Fast gives faster performance; and Slow gives more stable performance. This field applies only when synchronous DRAM is installed in the system.

The Choice: 2, 3.

System BIOS Cacheable

Selecting Enabled allows caching of the system BIOS ROM at F0000h-FFFFFh, resulting in better system performance. However, if any program writes to this memory area, a system error may result.

The choice: Enabled, Disabled.

Video BIOS Cacheable

Select Enabled allows caching of the video BIOS, resulting in better system performance. However, if any program writes to this memory area, a system error may result.

The Choice: Enabled, Disabled.

Memory Hole At 15M-16M

You can reserve this area of system memory for ISA adapter ROM. When this area is reserved, it cannot be cached. The user information of peripherals that need to use this area of system memory usually discusses their memory requirements.

The Choice: Enabled, Disabled.

CPU Latency Timer

When enabled this item, the CPU cycle will only be deferred after it has been held in a noop Stall for 31 clocks and another ADS# has arrived. When disabled, the CPU cycle will be deferred immediately after the GMCH receives another ADS#.

The Choice: Enabled, Disabled.

Delayed Transaction

The chipset has an embedded 32-bit posted write buffer to support delay transactions cycles. Select Enabled to support compliance with PCI specification version 2.1.

The Choice: Enabled, Disabled

AGP Graphics Aperture Size

This field determines the effective size of the Graphic Aperture used for a particular GMCH configuration. It can be updated by the GMCH-specific BIOS configuration sequence before the PCI standard bus enumeration sequence takes place. If it is not updated then a default value will select an aperture of maximum size.

The choice: 4, 8, 16, 32, 64, 128, 256

Display Cache Frequency

You can use this item to select the frequency of the display cache.

The Choice: 100MHZ, 133MHZ.

System Memory Frequency

You can use this item to select the operating frequency for the main system memory.

The Choice: Auto, 100MHZ, 133MHZ.

On-Chip Video Window Size

Select the on-chip video window size for VGA drives use.

The Choice: 32MB, 64MB, Disabled.

Onboard Display Cache Setting

Setting the onboard display cache timing.

CAS # Latency

Select the local memory clock periods.

The Choice: 2, 3

Paging Mode Control

Select the paging mode control.

The Choice: Close, Open.

RAS-to-CAS Override

Select the display cache clock periods control.

The Choice: Fast, Slow.

RAS# Timing

This item controls RAS# active to Protegra, and refresh to RAS# active delay (in local memory clocks).

The Choice: Fast, Slow.

RAS# Precharge Timing

This item controls RAS# precharge (in local memory clocks).

The choice: Fast, Slow.

Integrated Peripherals

CMOS Setup Utility - Copyright (C) 1984-2000 Award Software
 Integrated Peripherals

Onboard LAN2 H/W Active	Enabled	▲ ▼	Item Help
Onboard SCSI H/W Active	Enabled		Menu Level ▶
Onboard LAN Boot ROM	Disabled		
Onboard SCSI Boot ROM	Enabled		
On-Chip Primary PCI IDE	Enabled		
On-Chip Secondary PCI IDE	Enabled		
IDE Primary Master PIO	Auto		
IDE Primary Slave PIO	Auto		
IDE Secondary Master PIO	Auto		
IDE Secondary Slave PIO	Auto		
IDE Primary Master UDMA	Auto		
IDE Primary Slave UDMA	Auto		
IDE Secondary Master UDMA	Auto		
IDE Secondary Slave UDMA	Auto		
USB Controller	Enabled		
USB Keyboard Support	Disabled		
Init Display First	PCI Slot		
IDE HDD Block Mode	Enabled		
POWER ON Function	Any KEY		
KB Power ON Password	Enter		
Hot Key Power ON	Ctrl-F1		
Onboard FDC Controller	Enabled		
Onboard Serial Port 1	3F8/IRQ4		
Onboard Serial Port 2	2F8/IRQ3		
UART Mode Select	Normal		
UR2 Duplex Mode	Half		
Onboard Parallel Port	378/IRQ7		
Parallel Port Mode	SPP		
ECP Mode Use DMA	3		

↑↓←→:Move Enter:Select +/-/PU/PD:Value F10:Save ESC:Exit F1:General Help
 F5:Previous Values F6:Fail-Safe Defaults F7:Optimized Defaults

Onboard LAN2 H/W Active

This setting enables or disables the onboard LAN2.

The choice: Enabled, Disabled.

Onboard SCSI H/W Active

This setting enables or disables the onboard SCSI.

The choice: Enabled, Disabled.

Onboard LAN Boot ROM

Decide whether to invoke the boot ROM of the onboard LAN chip.

The choice: LAN1, LAN2, Disabled.

Onboard SCSI Boot ROM

Decide whether to invoke the boot ROM of the onboard SCSI.

The choice: Enabled, Disabled.

On-Chip Primary/Secondary PCI IDE

The chipset contains a PCI IDE interface with support for two IDE channels. Select Enabled to activate the primary/secondary IDE interface. Select Disabled to deactivate the primary/secondary IDE

The choice: Enabled, Disabled.

Note: 1. On-chip Secondary PCI IDE:

Enabled: enable secondary IDE port and BIOS will assign IRQ15 for this port.

Disabled: disable secondary IDE port and IRQ15 is available for other device. The item is optional only for PCI BIOS.

2. Some of the sound cards have an onboard CD-ROM controller, which uses IDE Secondary Port. In order to avoid PCI IDE conflict, the IDE secondary channel control has to select Disabled then CD-ROM can work.

IDE Primary/Secondary Master/Slave PIO

The four IDE PIO (Programmed Input/Output) fields let you set a PIO mode (0-4) for each of the four IDE devices that the on-Board IDE interface supports. Modes 0 through 4 provide successively increased performance. In Auto mode, the system automatically determines the best mode for each device.

The Choice: Auto, Mode 0, Mode 1, Mode 2, Mode 3 and Mode 4.

IDE Primary/Secondary Master/Slave UDMA

Ultra DMA/33 implementation is possible only if your IDE hard drive supports it and the operating environment includes a DMA driver (Windows 95 OSR2 or a third-party IDE bus master driver). If your hard drive and your system software both support Ultra DMA/33, select Auto to enable BIOS support.

The Choice: Auto, Disabled.

USB Controller

Select *Enabled* if your system contains a Universal Serial Bus (USB) controller and you have USB peripherals.

The Choice: Enabled, Disabled.

USB Keyboard Support

Select Enabled if your system contains a Universal Serial Bus (USB) controller and you have a USB keyboard.

The Choice: Enabled, Disabled.

Init Display First

This item allows you to decide to active whether PCI Slot or on-chip VGA first

The Choice: PCI Slot, Onboard.

IDE HDD Block Mode

Block mode is also called block transfer, multiple commands, or multiple sector read/write. If your IDE hard drive supports block mode (most new drives do), select Enabled for automatic detection of the optimal number of block read/writes per sector the drive can support.

The Choice: Enabled, Disabled

Onboard FDC Controller

Select Enabled if your system has a floppy disk controller (FDC) installed on the system board and you wish to use it. If you install add-on FDC Controller Card or the system has no floppy drive, select Disabled in this field.

The Choice: Enabled, Disabled.

Onboard Serial Port 1/Port 2

Select an address and corresponding interrupt for the first and second serial ports.

The Choice: 3F8/IRQ4, 2E8/IRQ3, 3E8/IRQ4, 2F8/IRQ3, Disabled, Auto.

UART Mode Select

This item allows you to select UART mode.

The Choice: Normal, .IrDA, ASKIR

UR2 Duplex Mode

This item allows you to select the IR half/full duplex function.

The Choice: Half, Full.

Onboard Parallel Port

This item allows you to determine access On-Board parallel port controller with which I/O address.

The Choice: 3BC/IRQ7, 378/IRQ7, 278/IRQ5, Disabled.

Parallel Port Mode

Select an operating mode for the On-Board parallel (printer) port. Select *Normal*, *Compatible*, or *SPP* unless you are certain your hardware and software both support one of the other available modes.

The Choice: SPP, EPP, ECP, ECP+EPP.

ECP Mode Use DMA

Select a DMA channel for the parallel port for use during ECP mode.

The Choice: 3, 1.

Power Management Setup

The Power Management Setup allows you to configure your system to most effectively save energy while operating in a manner consistent with your own style of computer use.

CMOS Setup Utility - Copyright (C) 1984-2000 Award Software
Power Management Setup

ACPI Function	Enabled	▲ ↑ ↓ ▼	Item Help	
ACPI Suspend Type	S1(POS)		Menu Level ▶	
Power Management	Min Saving			
Video Off Method	DPMS			
Video Off In Suspend	Yes			
Suspend Type	Stop Grant			
MODEM Use IRQ	3			
Suspend Mode	Disabled			
HDD Power Down	15 Min			
Soft-Off by PWR-BTTN	Instant-Off			
Wake-Up by PCI card	Disabled			
Power On by Ring	Enabled			
USB KB Wake-Up From S3	Disabled			
Resume by Alarm	Disabled			
x Date(of Month) Alarm	0			
x Time(hh:mm:ss) Alarm	0 0 0			
** Reload Global Timer Events **				
Primary IDE 0	Disabled			
Primary IDE 1	Disabled			
Secondary IDE 0	Disabled			
Secondary IDE 1	Disabled			
FDD, COM, LPT Port	Disabled			
PCI PIRQ[A-D]#	Disabled			

↑↓←→:Move Enter:Select +/-/PU/PD:Value F10:Save ESC:Exit F1:General Help
F5:Previous Values F6:Fail-Safe Defaults F7:Optimized Defaults

ACPI Function

This item allows you to Enable/Disable the Advanced Configuration and Power Interface (ACPI).

The Choice: Enabled, Disabled.

ACPI Suspend Mode

This item will allow you to select the ACPI suspend type. You can select S3 (STR) for suspending to DRAM or S1 (POS) for power on suspend under Windows 98 ACPI mode.

The choice: S1(POS), S3(STR).

Power Management

This category allows you to select the type (or degree) of power saving and is directly related to the following modes:

1. HDD Power Down
2. Doze Mode
3. Suspend Mode

There are four selections for Power Management, three of which have fixed mode settings.

Disabled (default)	No power management. Disables all four modes
Min. Power Saving	Minimum power management. Doze Mode = 1 hr. Standby Mode = 1 hr., Suspend Mode = 1 hr., and HDD Power Down = 15 min.
Max. Power Saving	Maximum power management -- ONLY AVAILABLE FOR SL CPU . Doze Mode = 1 min., Standby Mode = 1 min., Suspend Mode = 1 min., and HDD Power Down = 1 min.
User Define	Allows you to set each mode individually. When not disabled, each of the ranges are from 1 min. to 1 hr. except for HDD Power Down which ranges from 1 min. to 15 min. and Disabled.

Video Off Method

This determines the manner in which the monitor is blanked.

V/H SYNC+Blank	This selection will cause the system to turn off the vertical and horizontal synchronization ports and write blanks to the video buffer.
Blank Screen	This option only writes blanks to the video buffer.
DPMS	Initial display power management signaling.

Video Off In Suspend

This determines the manner in which the monitor is blanked.

The Choice: Yes, No.

Suspend Type

Select the Suspend Type.

The Choice: PWRON Suspend, Stop Grant.

MODEM Use IRQ

This determines the IRQ in which the MODEM can use.

The Choice: 3, 4, 5, 7, 9, 10, 11, NA.

Suspend Mode

When enabled and after the set time of system inactivity, all devices except the CPU will be shut off.

The Choice: Enabled, Disabled.

HDD Power Down

When enabled and after the set time of system inactivity, the hard disk drive will be powered down while all other devices remain active.

The Choice: Enabled, Disabled.

Soft-Off by PWR-BTTN

Pressing the power button for more than 4 seconds forces the system to enter the Soft-Off state when the system has `ung`

The Choice: Delay 4 Sec, Instant-Off.

Wake-Up by PCI card

When enabled, you can wake-up your system using a PCI rev2.2 card, when a `ME#` event occurring.

The Choice: Enabled, Disabled.

PowerOn by Ring

An input signal on the serial Ring Indicator (RI) line (in other words, an incoming call on the modem) awakens the system from a soft off state.

The choice: Enabled, Disabled.

USB KB Wake-Up From S3

This item will enable you to wake-up the system by USB keyboard when you shut down the computer in S3 mode.

The choice: Enabled, Disabled.

Resume by Alarm

When Enabled, you can set the date and time at which the RTC (real-time clock) alarm awakens the system from Suspend mode.

The choice: Enabled, Disabled.

PM Events (Reload Global Timer Events)

PM events are I/O events whose occurrence can prevent the system from entering a power saving mode or can awaken the system from such a mode. In effect, the system remains alert for anything which occurs to a device which is configured as Enabled, even when the system is in a power down mode.

Primary IDE 0

Primary IDE 1

Secondary IDE 0

Secondary IDE 1

FDD, COM, LPT Port

PCI PIRQ[A-D] #

PnP/PCI Configuration

This section describes configuring the PCI bus system. Peripheral Component Interface, is a system which allows I/O devices to operate at speeds nearing the speed the CPU itself uses when communicating with its own special components. This section covers some very technical items and it is strongly recommended that only experienced users should make any changes to the default settings.

CMOS Setup Utility - Copyright (C) 1984-2000 Award Software PnP/PCI Configurations

		Item Help
PNP OS Installed	Yes	Menu Level ▶ Select Yes if you are using a Plug and Play capable operating system Select No if you need the BIOS to configure non-boot devices
Reset Configuration Data	Disabled	
Resources Controlled By	Auto(ESCD)	
M-System Memory Base	N/A	
x IRQ Resources	Press Enter	
x DMA Resources	Press Enter	
x Memory Resources	Press Enter	
PCI/VGA Palette Snoop	Disabled	
Assign IRQ For USB	Enabled	
INT Pin 1 Assignment	Auto	
INT Pin 2 Assignment	Auto	
INT Pin 3 Assignment	Auto	
INT Pin 4 Assignment	Auto	

↑↓→←:Move Enter:Select +/-/PU/PD:Value F10:Save ESC:Exit F1:General Help
F5:Previous Values F6:Fail-Safe Defaults F7:Optimized Defaults

PNP OS Installed

Select Yes if the system operating environment is Plug-and-Play aware (e.g. Windows 95).

The Choice: Yes, No.

Reset Configuration Data

Normally, you leave this field Disabled. Select Enabled to reset Extended System Configuration Data (ESCD) when you exit Setup if you have installed a new add-on Card and the system reconfiguration has caused such a serious conflict that the operating system can not boot.

The choice: Enabled, Disabled .

Resources Controlled by

The Award Plug and Play BIOS has the capacity to automatically configure all of the boot and Plug and Play compatible devices. However, this capability means absolutely nothing unless you are using a Plug and Play operating system such as Windows®95. If you set this field to manual choose specific resources by going into each of the sub menu that follows this field.

The Choice: Auto (ESCD), Manual.

M-System Memory Base

This function will be available when “**Resources Controlled by**” set to Manual

The Choice: N/A, C000, C800, D000, D800

IRQ/DMA Assigned To

This item allows you to determine the IRQ / DMA assigned to the ISA bus and is not available to any PCI slot. (Legacy ISA) or PnP for both ISA and PCI.

Choices are *Legacy ISA* and *PCI/ISA PnP*.

Memory Resources

Used MEM Base Addr

Some add-in cards ask for a specific address space in the system memory. This field specifies the memory base (start address) of the reserved memory space.

The Choice: N/A, C800, CC00, D000, D400, D800, DC00

Used MEM Length

This item is available only when the Used MEM Base Addr has been assigned a base address. It specifies the memory size for the add-in card used.

The Choice: 8K, 16K, 32K, 64K

PCI/VGA Palette Snoop

Leave this field at Disabled.

The Choice: Enabled, Disabled.

Assign IRQ For VGA/USB

Enabled/Disable to assign a IRQ for VGA/USB.

The Choice: Enabled, Disabled.

PC Health Status

CMOS Setup Utility - Copyright (C) 1984-2000 Award Software
PC Health Status

Shutdown Temperature	60°C/140°F	Item Help
Voltage Vcore1		Menu Level ▶
Voltage Vcore2		
Voltage 3.3V		
Voltage 5V		
Voltage 12V		
Voltage -12V		
Voltage -5V		
Voltage 5VSB		
Voltage Battery		
Temperature CPU		
Temperature System		
Fan Speed		

↑↓→←:Move Enter:Select +/-/PU/PD:Value F10:Save ESC:Exit F1:General Help
F5:Previous Values F6:Fail-Safe Defaults F7:Optimized Defaults

Shutdown Temperature

This item allows you to set up the CPU shutdown Temperature. This item only effective under Windows 98 ACPI mode.

The Choice: Disabled, 60°C/140°F, 65°C/149°F.

Frequency/Voltage Control

CMOS Setup Utility - Copyright (C) 1984-2000 Award Software
Frequency/Voltage Control

Auto Detect DIMM/PCI Clk	Enabled	Item Help
Spread Spectrum	Disabled	
CPU HOST/PCI Clock/PC133	Default	Menu Level ▶
CPU Clock Ratio	X 3	

↑↓→←:Move Enter:Select +/-/PU/PD:Value F10:Save ESC:Exit F1:General Help
F5:Previous Values F6:Fail-Safe Defaults F7:Optimized Defaults

Auto Detect DIMM/PCI Clk

When enabled, this item will auto detect if the DIMM and PCI socket have devices and will send clock signal to DIMM and PCI devices. When disabled, it will send the clock signal to all DIMM and PCI socket.

The choice: Enabled, Disabled.

Spread Spectrum

This item allows you to enable/disable the spread spectrum modulate.

The choice: Enabled, Disabled.

CPU Host/PCI Clock/PC133

This item allows you to slightly adjust the clock frequency.

The choice: 66MHZ~166MHZ.

CPU Clock Ratio

This item allows you to set up the CPU clock ratio, but this function depends on different CPU performance. It is only effective for those clock ratio haven't been locked.

The choice: X3~X8

Supervisor/User Password Setting

You can set either supervisor or user password, or both of them. The differences between are:

supervisor password : can enter and change the options of the setup menus.

user password : just can only enter but do not have the right to change the options of the setup menus. When you select this function, the following message will appear at the center of the screen to assist you in creating a password.

ENTER PASSWORD:

Type the password, up to eight characters in length, and press <Enter>. The password typed now will clear any previously entered password from CMOS memory. You will be asked to confirm the password. Type the password again and press <Enter>. You may also press <Esc> to abort the selection and not enter a password.

To disable a password, just press <Enter> when you are prompted to enter the password. A message will confirm the password will be disabled. Once the password is disabled, the system will boot and you can enter Setup freely.

PASSWORD DISABLED

When a password has been enabled, you will be prompted to enter it every time you try to enter Setup. This prevents an unauthorized person from changing any part of your system configuration.

Additionally, when a password is enabled, you can also require the BIOS to request a password every time your system is rebooted. This would prevent unauthorized use of your computer.

You determine when the password is required within the BIOS Features Setup Menu and its Security option (see Section 3). If the Security option is set to system the password will be required both at boot and at entry to Setup. If set to setup prompting only occurs when trying to enter Setup.

Power-On Boot

After you have made all the changes to CMOS values and the system cannot boot with the CMOS values selected in Setup, restart the system by turning it OFF then ON or Pressing the "RESET" button on the system case. You may also restart by simultaneously press **<Ctrl>**, **<Alt>**, and **<Delete>** keys.

Upon restart the system, immediately press **<Insert>** to load BIOS default CMOS value for boot up.

4-2 BIOS Reference - POST Message

During the Power On Self Test (POST), if the BIOS detects an error requiring you to do something to fix, it will either sound a beep code or display a message.

If a message is displayed, it will be accompanied by:

PRESS <F1> TO CONTINUE, <CTRL>-<ALT>-<ESC> OR TO ENTER SETUP

POST Beep

Currently there is only one beep code in BIOS. This code indicates that a video error has occurred and the BIOS cannot initialize the video screen to display any additional information. This beep code consists of a single long beep followed by two short beeps.

Error Messages

One or more of the following messages may be displayed if the BIOS detects an error during the POST. This list includes messages for both the ISA and the EISA BIOS.

BIOS ROM checksum error-System halted.

The checksum of ROM address F0000H-FFFFFFH is bad.

CMOS BATTERY HAS FAILED

CMOS battery is no longer functional. It should be replaced.

CMOS CHECKSUM ERROR

Checksum of CMOS is incorrect. This can indicate that CMOS has become corrupt. This error may have been caused by a weak battery. Check the battery and replace if necessary.

DISK BOOT FAILURE, INSERT SYSTEM DISK AND PRESS ENTER

No boot device was found. This could mean that either a boot drive was not detected or the drive does not contain proper system boot files. Insert a system disk into Drive A: and press <Enter>. If you assumed the system would boot from the hard drive, make sure the controller is inserted correctly and all cables are properly attached. Also be sure the disk is formatted as a boot device. Then reboot the system.

DISKETTE DRIVES OR TYPES MISMATCH ERROR - RUN SETUP

Type of diskette drive installed in the system is different from the CMOS definition. Run Setup to reconfigure the drive type correctly.

DISPLAY SWITCH IS SET INCORRECTLY

Display switch on the motherboard can be set to either monochrome or color. This indicates the switch is set to a different setting than indicated in Setup. Determine which setting is correct, and then either turn off the system and change the jumper, or enter Setup and change the VIDEO selection.

DISPLAY TYPE HAS CHANGED SINCE LAST BOOT

Since last powering off the system, the display adapter has been changed. You must configure the system for the new display type.

**EISA Configuration Checksum Error
PLEASE RUN EISA CONFIGURATION UTILITY**

The EISA non-volatile RAM checksum is incorrect or cannot correctly read the EISA slot. This can indicate either the EISA non-volatile memory has become corrupt or the slot has been configured incorrectly. Also be sure the card is installed firmly in the slot.

**EISA Configuration Is Not Complete
PLEASE RUN EISA CONFIGURATION UTILITY**

The slot configuration information stored in the EISA non-volatile memory is incomplete.

Note: When either of these errors appear, the system will boot in ISA mode, which allows you to run the EISA Configuration Utility.

ERROR ENCOUNTERED INITIALIZING HARD DRIVE

Hard drive cannot be initialized. Be sure the adapter is installed correctly and all cables are correctly and firmly attached. Also be sure the correct hard drive type is selected in Setup.

ERROR INITIALIZING HARD DISK CONTROLLER

Cannot initialize controller. Make sure the cord is correctly and firmly installed in the bus. Be sure the correct hard drive type is selected in Setup. Also check to see if any jumper needs to be set correctly on the hard drive.

FLOPPY DISK CONTROLLER ERROR OR NO CONTROLLER PRESENT

Cannot find or initialize the floppy drive controller. Make sure the controller is installed correctly and firmly. If there are no floppy drives installed, be sure the Diskette Drive selection in Setup is set to NONE.

FLOPPY DISK(S) fail (80)

Unable to reset floppy subsystem.

FLOPPY DISK(S) fail (40)

Floppy Type mismatch.

Hard Disk(s) fail (80)

HDD reset failed

Hard Disk(s) fail (40)

HDD controller diagnostics failed.

Hard Disk(s) fail (20)

HDD initialization error.

Hard Disk(s) fail (10)

Unable to recalibrate Hard Disk.

Hard Disk(s) fail (08)

Sector Verify failed.

Invalid EISA Configuration**PLEASE RUN EISA CONFIGURATION UTILITY**

The non-volatile memory containing EISA configuration information was programmed incorrectly or has become corrupt. Re-run EISA configuration utility to correctly program the memory.

NOTE: When this error appears, the system will boot in ISA mode, which allows you to run the EISA Configuration Utility.

KEYBOARD ERROR OR NO KEYBOARD PRESENT

Cannot initialize the keyboard. Make sure the keyboard is attached correctly and no keys are being pressed during the boot.

If you are purposely configuring the system without a keyboard, set the error halt condition in Setup to ALT ON item to LL BUT KEYBOARD. This will cause the BIOS to ignore the missing keyboard and continue the boot.

KEYBOARD IS LOCKED OUT-UNLOCK THE KEY

BIOS detect the keyboard is locked. P17 of keyboard controller is pulled low.

MANUFACTURING POST LOOP

System will repeat POST procedure infinitely while the P15 of keyboard controller is pulled low. This is also used for M/B burn in test.

MEMORY ADDRESS ERROR AT ...

Indicates a memory address error at a specific location. You can use this location along with the memory map for your system to find and replace the bad memory chips.

MEMORY TEST FAIL

BIOS reports the memory test fail if the On-Board memory is tested error.

MEMORY PARITY ERROR AT ...

Indicates a memory parity error at a specific location. You can use this location along with the memory map for your system to find and replace the bad memory chips.

MEMORY SIZE HAS CHANGED SINCE LAST BOOT

Memory has been added or removed since the last boot. In EISA mode use Configuration Utility to reconfigure the memory configuration. In ISA mode enter Setup and enter the new memory size in the memory fields.

MEMORY VERIFY ERROR AT ...

Indicates an error verifying a value already written to memory. Use the location along with your system's memory map to find and replace the bad memory chips

OFFENDING ADDRESS NOT FOUND

This message is used in conjunction with the I/O CHANNEL CHECK and RAM PARITY ERROR messages when the Address that has caused the problem cannot be isolated.

OFFENDING SEGMENT:

This message is used in conjunction with the I/O CHANNEL CHECK and RAM PARITY ERROR messages when the segment that has caused the problem has been isolated.

PRESS A KEY TO REBOOT

This will be displayed at the bottom screen when an error occurs that requires you to reboot. Press any key and the system will reboot.

PRESS F1 TO DISABLE NMI, F2 TO REBOOT

When BIOS detects a Non-maskable Interrupt condition during boot, this will allow you to disable the NMI and continue to boot, or you can reboot the system with the NMI enabled.

RAM PARITY ERROR - CHECKING FOR SEGMENT ...

Indicates a parity error in Random Access Memory.

**Should Be Empty But EISA Board Found
PLEASE RUN EISA CONFIGURATION UTILITY**

A valid board ID was found in a slot that was configured as having no board ID.

NOTE: When this error appears, the system will boot in ISA mode, which allows you to run the EISA Configuration Utility.

**Should Have EISA Board But Not Found
PLEASE RUN EISA CONFIGURATION UTILITY**

The board installed is not responding to the ID request, or no board ID has been found in the indicated slot.

NOTE: When this error appears, the system will boot in ISA mode, which allows you to run the EISA Configuration Utility.

Slot Not Empty

Indicates that a slot designated as empty by the EISA Configuration Utility actually contains a board.

NOTE: When this error appears, the system will boot in ISA mode, which allows you to run the EISA Configuration Utility.

SYSTEM HALTED, (CTRL-ALT-DEL) TO REBOOT ...

Indicates the present boot attempt has been aborted and the system must be rebooted. Press and hold down the CTRL and ALT keys and press DEL.

**Wrong Board In Slot
PLEASE RUN EISA CONFIGURATION UTILITY**

The board ID does not match the ID stored in the EISA non-volatile memory.

NOTE: When this error appears, the system will boot in ISA mode, which allows you to run the EISA Configuration Utility.

4-3 BIOS Reference - POST Codes

POST (hex)	Description
CFh	Test CMOS R/W functionality.
C0h	Early chipset initialization: -Disable shadow RAM -Disable L2 cache (socket 7 or below). -Program basic chipset registers.
C1h	Detect memory -Auto-detection of DRAM size, type and ECC. -Auto-detection of L2 cache (socket 7 or below).
C3h	Expand compressed BIOS code to DRAM.
C5h	Call chipset hook to copy BIOS back to E000h & F000h shadow RAM..
01h	Expand the Xgroup codes locating in physical address 1000h:0.
02h	Reserved.
03h	Initial Superio_Early_Init switch.
04h	Reserved.
05h	1. Blank out screen. 2. Clear CMOS error flag.
06h	Reserved.
07h	1. Clear 8042 interface. 2. Initialize 8042 self-test.
08h	1. Test special keyboard controller for Winbond 977 series Super I/O chips. 2. Enable keyboard interface.
09h	Reserved.
0Ah	1. Disable PS/2 mouse interface (optional). 2. Auto detect ports for keyboard & mouse followed by a port & interface swap (optional). 3. Reset keyboard for Winbond 977 series Super I/O chips.
0Bh	Reserved
0Ch	Reserved
0Dh	Reserved
0Eh	Test F000h segment shadow to see whether it is R/W-able or not. If test fails, keep beeping the speaker.
0Fh	Reserved
10h	Auto detect flash type to load appropriate flash R/W codes into the run time area in F000

POST (hex)	Description
	for ESCD & DMI support.
11h	Reserved
12h	Use walking 1 algorithm to check out interface in CMOS circuitry. Also set real-time clock power status, and then check for override.
13h	Reserved
14h	Program chipset default values into chipset. Chipset default values are MODBINable by OEM customers.
15h	Reserved
16h	Initial Early_Init_Onboard_Generator switch.
17h	Reserved
18h	Detect CPU information including brand, SMI type (Cyrix or Intel) and CPU level (586 or 686).
19h	Reserved
1Ah	Reserved
1Bh	Initial interrupts vector table. If no special specified, all H/W interrupts are directed to SPURIOUS_INT_HDLR & S/W interrupts to SPURIOUS_soft_HDLR.
1Ch	Reserved
1Dh	Initial EARLY_PM_INIT switch.
1Eh	Reserved
1Fh	Load keyboard matrix (notebook platform).
20h	Reserved
21h	HPM initialization (notebook platform).
22h	Reserved
23h	<ol style="list-style-type: none"> 1. Check validity of RTC value: e.g. a value of 5Ah is an invalid value for RTC minute. 2. Load CMOS settings into BIOS stack. If CMOS checksum fails, use default value instead. 3. Prepare BIOS resource map for PCI & PnP use. If ESCD is valid, take into consideration of the ESCD legacy information. 4. Onboard clock generator initialization. Disable respective clock resource to empty PCI & DIMM slots. 5. Early PCI initialization: <ul style="list-style-type: none"> -Enumerate PCI bus number -Assign memory & I/O resource -Search for a valid VGA device & VGA BIOS, and put it into C000h:0.

POST (hex)	Description
24h	Reserved
25h	Reserved
26h	Reserved
27h	Initialize INT 09h buffer
28h	Reserved
29h	<ol style="list-style-type: none"> 1. Program CPU internal MTRR (P6 & PII) for 0-640KB memory address. 2. Initialize the APIC for Pentium class CPU. 3. Program early chipset according to CMOS setup. Example: On-Board IDE controller. 4. Measure CPU speed. 5. Invoke video BIOS.
2Ah	Reserved.
2Bh	Reserved.
2Ch	Reserved.
2Dh	<ol style="list-style-type: none"> 1. Initialize multi-language . 2. Put information on screen display, including Award title, CPU type, CPU speed
2Eh	Reserved.
2Fh	Reserved.
30h	Reserved.
31h	Reserved.
32h	Reserved.
33h	Reset keyboard except Winbond 977 series Super I/O chips.
34h	Reserved.
35h	Reserved.
36h	Reserved.
37h	Reserved.
38h	Reserved.
39h	Reserved.
3Ah	Reserved.
3Bh	Reserved.
3Ch	Test 8254.
3Dh	Reserved.
3Eh	Test 8259 interrupt mask bits for channel 1.
3Fh	Reserved.

POST (hex)	Description
40h	Test 8259 interrupt mask bits for channel 2.
41h	Reserved.
42h	Reserved.
43h	Test 8259 functionality.
44h	Reserved.
45h	Reserved.
46h	Reserved.
47h	Initialize EISA slot.
48h	Reserved.
49h	1. Calculate total memory by testing the last double word of each 64KB page. 2. Program write allocation for AMD K5 CPU.
4Ah	Reserved.
4Bh	Reserved.
4Ch	Reserved.
4Dh	Reserved.
4Eh	1. Program MTRR of M1 CPU. 2. Initialize L2 cache for P6 class CPU & program CPU with proper cacheable range. 3. Initialize the APIC for P6 class CPU. 4. On MP platform, adjust the cacheable range to smaller one in case the cacheable ranges between each CPU are not identical.
4Fh	Reserved.
50h	Initialize U.SB
51h	Reserved.
52h	Test all memory (clear all extended memory to 0).
53h	Reserved.
54h	Reserved.
55h	Display number of processors (multi-processor platform).
56h	Reserved.
57h	1. Display PnP logo. 2. Early ISA PnP initialization. -Assign CSN to every ISA PnP device.
58h	Reserved.
59h	Initialize the combined Trend Anti-Virus code.

POST (hex)	Description
5Ah	Reserved.
5Bh	(Optional Feature). Show message for entering AWDFLASH.EXE from FDD (optional).
5Ch	Reserved.
5Dh	1. Initialize Init_Onboard_Super_IO switch. 2. Initialize Init_Onboard_AUDIO switch.
5Eh	Reserved
5Fh	Reserved
60h	Okay to enter Setup utility; i.e. not until this POST stage users can enter the CMOS setup utility.
61h	Reserved.
62h	Reserved.
63h	Reserved.
64h	Reserved.
65h	Initialize PS/2 Mouse.
66h	Reserved.
67h	Prepare memory size information for function call: INT 15h ax=E820h.
68h	Reserved.
69h	Turn on L2 cache.
6Ah	Reserved.
6Bh	Program chipset registers according to items described in Setup & Auto-configuration table.
6Ch	Reserved.
6Dh	1. Assign resources to all ISA PnP devices. 2. Auto assign ports to onboard COM ports if the corresponding item in Setup is set to UTO
6Eh	Reserved.
6Fh	1. Initialize Floppy controller. 2. Setup Floppy related fields in 40:hardware.
70h	Reserved.
71h	Reserved.
72h	Reserved.
73h	(Optional Feature).

POST (hex)	Description
	Enter AWDFLASH.EXE if : -AWDFLASH is found in Floppy Drive. - LT+F2 is pressed.
74h	Reserved.
75h	Detect & install all IDE devices: HDD, LS120, ZIP, CDROM .
76h	Reserved.
77h	Detect Serial ports & Parallel ports.
78h	Reserved.
79h	Reserved.
7Ah	Detect & install Co-processor.
7Bh	Reserved.
7Ch	Reserved.
7Dh	Reserved.
7Eh	Reserved.
7Fh	1. Switch back to text mode if full screen logo is supported. -If errors occur, report errors & wait for keys. -If no errors occur or 1 key is pressed to continue. 2. Clear EPA or customization logo.
80h	Reserved.
81h	Reserved.
E8POST.ASM starts	
82h	1. Call chipset power management hook. 2. Recover the text fond used by EPA logo (not for full screen logo). 3. If password is set, ask for password.
83h	Save all data in stack back to CMOS.
84h	Initialize ISA PnP boot devices.
85h	1. USB final Initialization. 2. NET PC: Build SYSID structure. 3. Switch screen back to text mode. 4. Set up ACPI table at top of memory. 5. Invoke ISA adapter ROMs. 6. Assign IRQs to PCI devices. 7. Initialize APM.

POST (hex)	Description
	8. Clear noise of IRQs.
86h	Reserved.
87h	Reserved.
88h	Reserved.
89h	Reserved.
90h	Reserved.
91h	Reserved.
92h	Reserved.
93h	Read HDD boot sector information for Trend Anti-Virus code.
94h	<ol style="list-style-type: none"> 1. Enable L2 cache. 2. Program boot up speed. 3. Chipset final initialization. 4. Power management final initialization. 5. Clear screen & display summary table. 6. Program K6 write allocation. 7. Program P6 class write combining.
95h	<ol style="list-style-type: none"> 1. Program daylight saving. 2. Update keyboard LED & typematic rate.
96h	<ol style="list-style-type: none"> 1. Build MP table. 2. Build & Update ESCD. 3. Set CMOS century to 20h or 19h. 4. Load CMOS time into DOS timer tick. 5. Build MSIRQ routing table.
FFh	Boot attempt (INT 19h).

This page is intentionally left blank.

Appendix

Appendix A Watch Dog Timer

Watch Dog Timer Working Procedure

The Watch Dog Timer (WDT) is the special hardware device. The WDT function is to monitor the computer system whether work normally, otherwise, it will have some measures to fix up the system.

It contains a receivable SQW signal from RTC, and could set time and can clear the counter function. When time is up, WDT can send Reset or NMI signal.

Operator has to write a value into WDT Configuration Register (Write the control value to the Configuration Port), and clear WDT counter (read the Configuration Port).

Watch Dog Timer character and function

WDT Configuration port	F2h	Default at F2h
Watch Dog Timer	Disabled	1. Default at Disabled
	Enabled	2. Enabled for user's programming
WDT Time out active for	Reset	Default at Reset
	NMI	
WDT Active Time	1 sec	Default at 64 sec
	2 sec	
	4 sec	
	8 sec	
	16 sec	
	32 sec	
	64 sec	

Watch Dog Timer Control Register

The Watch Dog Timer Control Register is to control the WDT working mode. You can write the value to WDT Configuration Port.

The following is the Control Register bit definition.

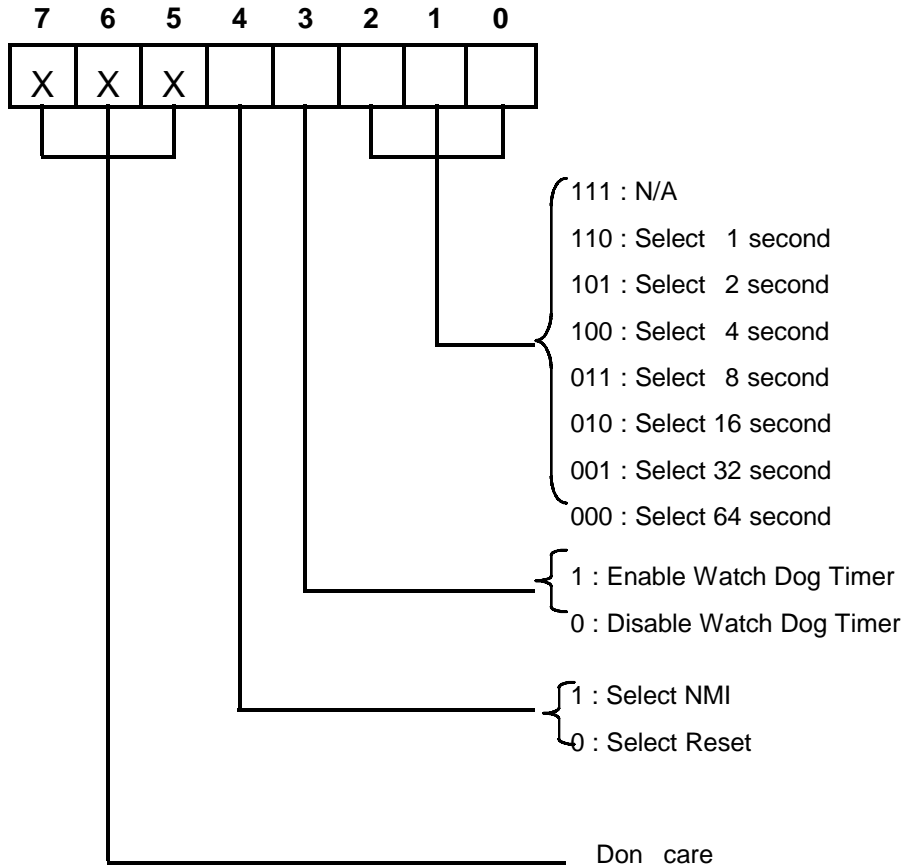

Watch Dog Timer Programming Procedure

- **Power on or reset the system**

The initial value of WDT Control Register (D4~D0) is zero, when power is on or reset the system. The following means the initial value of WDT (00000000b) :

Bit	Value	Mean
4	0	Select Reset
3	0	Disable Watch Dog Timer
2, 1, 0	0 0 0	Select 64 second

- **Initialize the SQW of RTC (set SQW output period=0.5 second)**

To initialize the SQW of RTC Component is to set the SQW signal which is output period=0.5 second. It offers the basic frequency of the WDT counter.

The following is an example of **initializing the SQW signal program** in Intel 8086 assembly language.

```

; (Generate SQW = 0.5 Sec.)
Mov  dx, 70h
      Mov    ax, 0Ah
      Out   dx, al           ; Out port 70h = 0Ah
      Mov   dx, 71h
      Mov   ax, 2Fh
      Out   dx, al           ; Out port 71h = 2Fh
      ; (enable the SQW output)
Mov   dx, 70h
      Mov   ax, 0Bh
      Out   dx, al           ; Out port 70h = 0Bh
      Mov   dx, 71h
      Mov   ax, 0Ah
      Out   dx, al           ; Out port 71h = 0Ah

```

- **Clear the WDT**

Repeatedly read WDT Configuration Port and the interval cannot be longer than the preset time, otherwise, the WDT will generate NMI or Reset signal for the system.

The following is an example of **clear the WDT program** in Intel 8086 assembly language.

```

; ( Clear the WDT)
Mov dx, F2h ; Setting the WDT configuration port
In  al, dx

```

Note: Before running WDT, you must clear the WDT. It means to make sure the initial value is zero before enabling the WDT.

- **WDT Control Register (Write to WDT configuration port)**

You can set the WDT Control Register to control the WDT working mode.

The initial value of the WDT Control Register is as the following.

```

; (Setting the WDT Control Register as AL)
Mov  al, 0h ; Setting initial value = 0 for the WDT Control Register

```

You must plan the option of following:

1. Select NMI or Reset: decide D4 value in F2h.

i.e. Setting D4 = 0, then it select Reset

```

AND  al, 11101111b ; Select Reset

```

i.e. Setting D4 = 1, then it select NMI

```

OR   al, 00010000b ; Select NMI

```

2. Select the time-out intervals of WDT (decide the values of D2, D1, D0 in F2h).

Example: D2~D0 = 0, the time-out interval will be 64 sec.

```

AND  al, 11111000b ; Setting the time-out interval as 64 sec.

```

3. Enabled or Disabled the WDT (decide D3 value in F2h).

i.e. D3=0, Disabled the WDT

```

AND  al, 11110111b ; Disable the WDT

```

i.e. D3=1, Enabled the WDT

```

OR   al, 00001000b ; Enable the WDT

```

After finishing the above setting, you must be output for the Control Register value to the WDT Configuration Port. Then WDT will start according to the above setting.

```
MOV dx, F2h ; Setting WDT Configuration Port
OUT dx, al ; Output the Control Register Value
```

You should build in a mechanism in the program to continue to read the WDT Configuration Port for clearing WDT before the time out.

Appendix B : DVI Interface Pin Assignment (for ATI Mobility M4 model only)

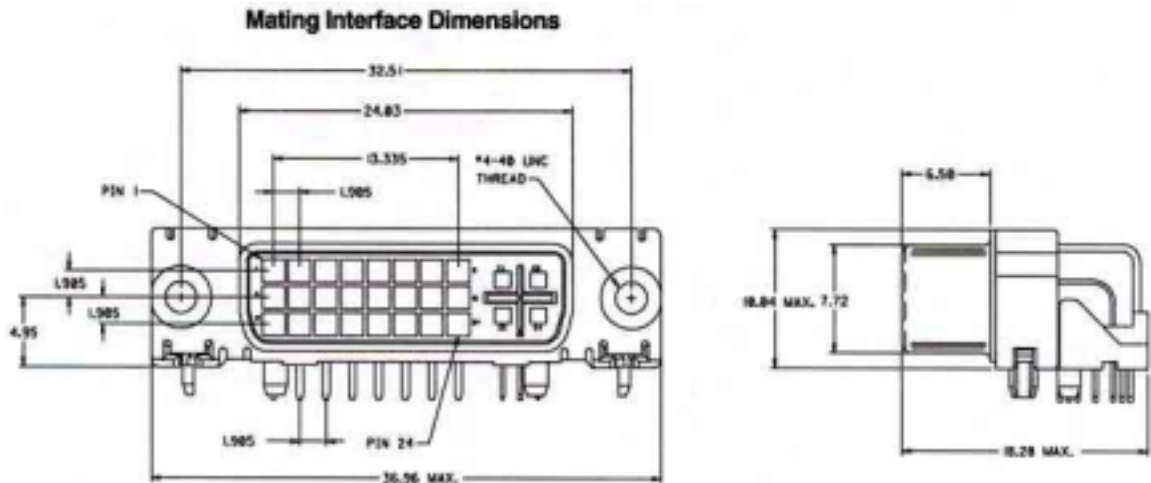

Pin	Signal Assignment	Pin	Signal Assignment	Pin	Signal Assignment
1	T.M.D.S. Data2-	9	T.M.D.S. Data1-	17	T.M.D.S. Data0-
2	T.M.D.S. Data2+	10	T.M.D.S. Data1+	18	T.M.D.S. Data0+
3	T.M.D.S. Data2/4 Shield	11	T.M.D.S. Data1/3 Shield	19	T.M.D.S. Data0/5 Shield
4	T.M.D.S. Data4-	12	T.M.D.S. Data3-	20	T.M.D.S. Data5-
5	T.M.D.S. Data4+	13	T.M.D.S. Data3+	21	T.M.D.S. Data5+
6	DDC Clock	14	+5V Power	22	T.M.D.S. Clock Shield
7	DDC Data	15	Ground (return for +5V, HSync, and VSync)	23	T.M.D.S. Clock+
8	Analog Vertical Sync	16	Hot Plug Detect	24	T.M.D.S. Clock-
C1	Analog Red	C2	Analog Green	C3	Analog Blue
C4	Analog Horizontal Sync	C5	Analog Ground (analog R, G, & B return)		

Combined Analog and Digital Connector Pin Assignments

Appendix C: CON1 Digital Video Signals Interface (12 bit)

1	LTV DATA 0	2	Vcc 1.8
3	LTV DATA 1	4	Vcc 1.8
5	LTV DATA 2	6	Vcc 1.8
7	LTV DATA 3	8	Vcc 1.8
9	LTV DATA 4	10	GND
11	LTV DATA 5	12	GND
13	LTV DATA 6	14	GND
15	LTV DATA 7	16	GND
17	LTV DATA 8	18	GND
19	LTV DATA 9	20	Vcc 3
21	LTV DATA 10	22	Vcc 3
23	LTV DATA 11	24	Vcc 3
25	LTV HSYNC	26	Vcc 3
27	LTV VSYNC	28	Vcc 5
29	LTV BLANK#	30	Vcc 5
31	LTV CLKOUT [0]	32	Vcc 5
33	LTV CLKOUT [1]	34	GND
35	TV CLKIN / INT#	36	PCI_RST#
37	LTV DA	38	5VFTSDA
39	LTV CK	40	5VFTSCL