

HOW TO ORDER REPLACEMENT PARTS

If you encounter any difficulties with this product, or if you need to order replacement parts, call the ICON Health & Fitness, Ltd. office, or write:

ICON Health & Fitness, Ltd.
Customer Service Department
Unit 4, Revie Road Industrial Estate
Beeston
Leeds, LS11 8JG
UK

Tel:

08457 089 009

Outside the UK: 0 (044) 113 387 7133
Fax: 0 (044) 113 387 7125

When ordering parts, please be prepared to give the following information:

- the MODEL NUMBER of the product (PFEVEX39910)
- the NAME of the product (PROFORM® 970 crosstrainer)
- the SERIAL NUMBER of the product (see the front cover of this manual)
- the KEY NUMBER and DESCRIPTION of the part(s) (see page 22 of this manual).

PROFORM is a registered trademark of ICON Health & Fitness, Inc.

PRO-FORM

CROSSTRAINER 970

USER'S MANUAL

Model No. PFEVEX39910
Serial No. _____

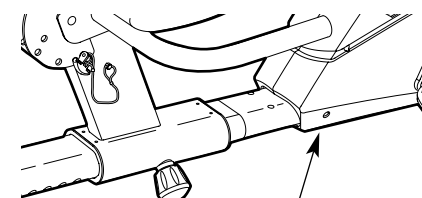

Serial Number Decal

QUESTIONS?

As a manufacturer, we are committed to providing complete customer satisfaction. If you have questions, or if there are missing or damaged parts, please call:

08457 089 009

Or write:
ICON Health & Fitness, Ltd.
Customer Service Department
Unit 4
Revie Road Industrial Estate
Beeston
Leeds, LS11 8JG
UK

email: csuk@iconeurope.com

CAUTION

Read all precautions and instructions in this manual before using this equipment. Keep this manual for future reference.

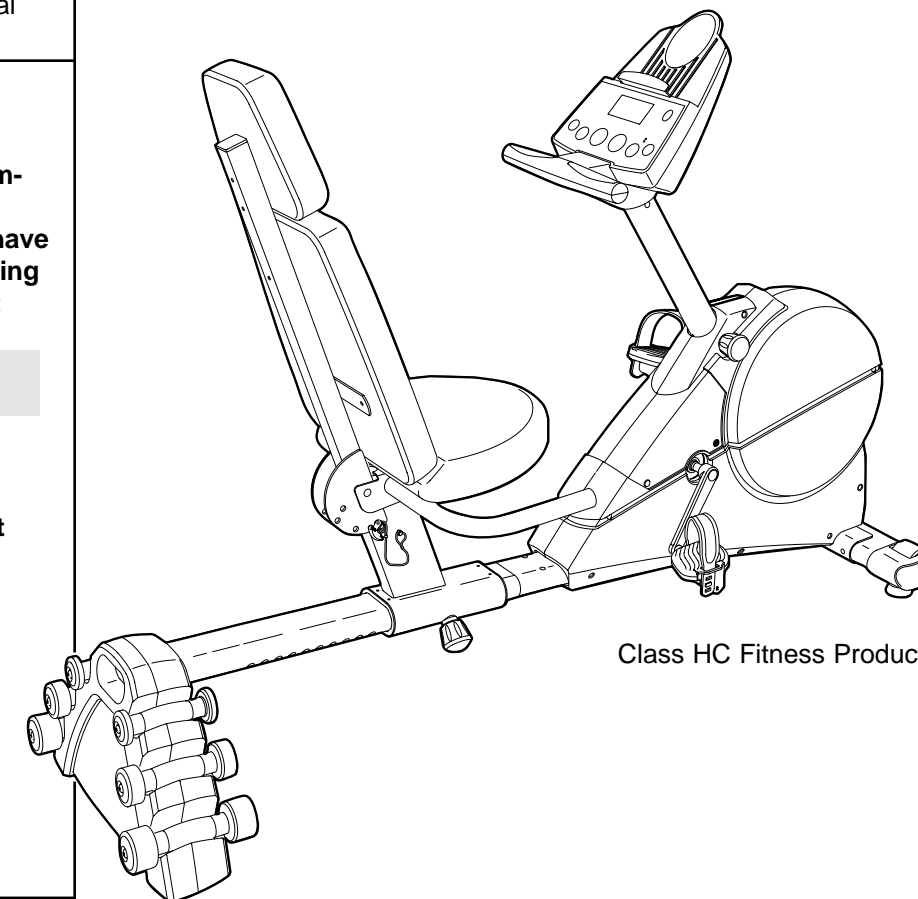

Class HC Fitness Product



Visit our website at

www.iconeurope.com

TABLE OF CONTENTS

IMPORTANT PRECAUTIONS2
 BEFORE YOU BEGIN3
 ASSEMBLY4
 HOW TO USE THE RECUMBENT CYCLE9
 RECUMBENT CYCLE EXERCISE GUIDELINES19
 WEIGHT BENCH EXERCISE GUIDELINES20
 MAINTENANCE AND TROUBLESHOOTING21
 PART LIST22
 EXPLODED DRAWING23
 HOW TO ORDER REPLACEMENT PARTSBack Cover

EXPLODED DRAWING—Model No. PFEVEX39910

R1201A

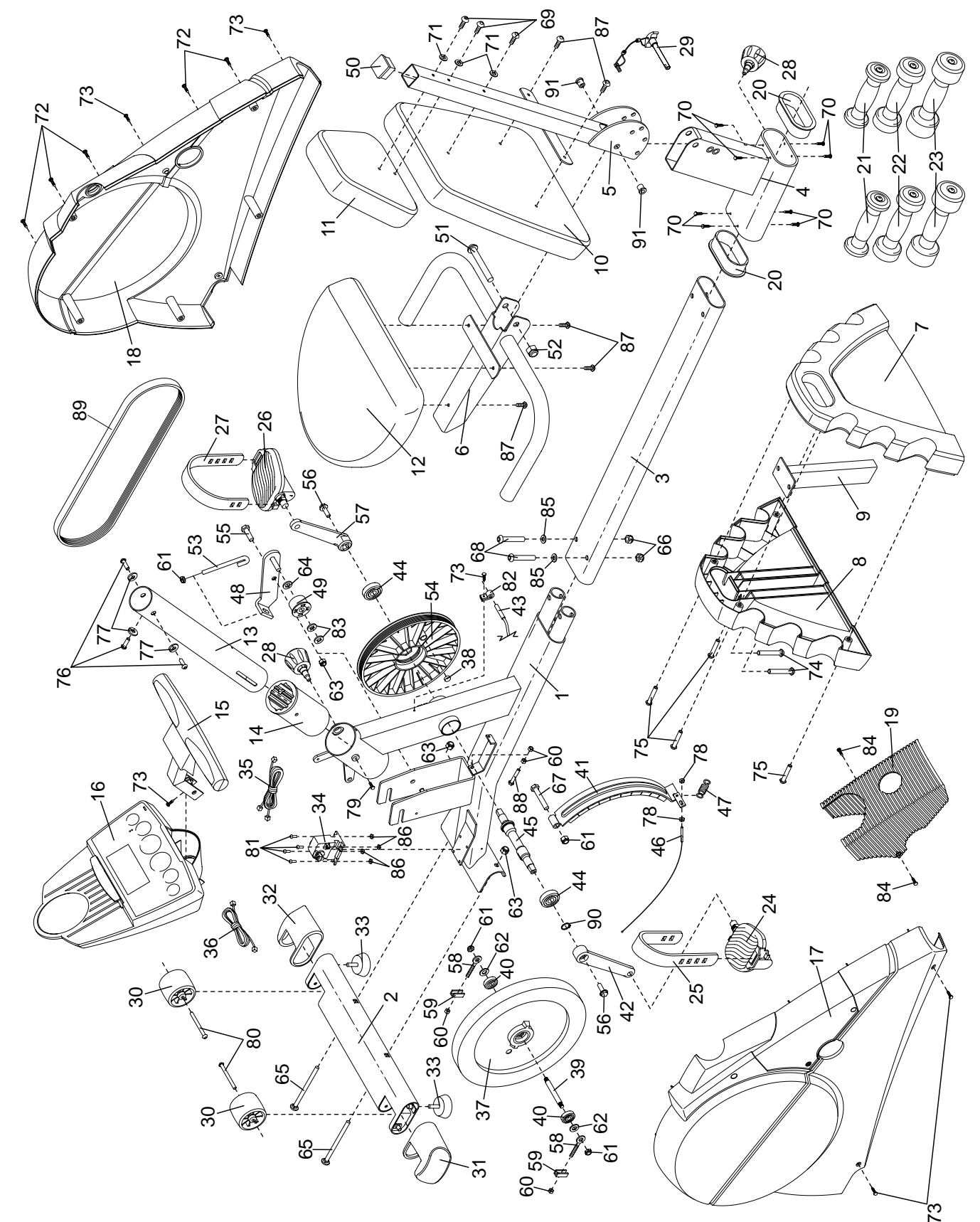

IMPORTANT PRECAUTIONS

⚠ WARNING: To reduce the risk of serious injury, read the following important precautions before using the crosstrainer.

- | | |
|--|--|
| <ol style="list-style-type: none"> 1. Read all instructions in this manual before using the crosstrainer. 2. It is the responsibility of the owner to ensure that all users of the crosstrainer are adequately informed of all precautions. 3. The crosstrainer is intended for home use only. Do not use the crosstrainer in a commercial, rental, or institutional setting. 4. Place the crosstrainer on a level surface, with a mat beneath it to protect the floor or carpet. Keep the crosstrainer indoors, away from moisture and dust. 5. Inspect and properly tighten all parts regularly. Replace any worn parts immediately. 6. Keep children under age 12 and pets away from the crosstrainer at all times. 7. The crosstrainer should not be used by persons weighing more than 114 kg (250 lbs.). 8. Wear appropriate exercise clothing when using the crosstrainer; do not wear clothing | <ol style="list-style-type: none"> 9. Before using the weight bench, always adjust the seat to the farthest forward position. Never sit on the backrest or the headrest; doing so could cause the crosstrainer to tip, resulting in injury. 10. Keep your back straight when using the crosstrainer; do not arch your back. 11. The crosstrainer includes three pairs of hand weights. Do not use other weights with the crosstrainer. 12. When you stop pedalling, allow the pedals to slowly come to a stop. 13. The pulse sensor is not a medical device. Various factors may affect the accuracy of heart rate readings. The pulse sensor is intended only as an exercise aid in determining heart rate trends in general. 14. If you feel pain or dizziness whilst exercising, stop immediately and begin cooling down. |
|--|--|

⚠ WARNING: Before beginning this or any exercise program, consult your physician. This is especially important for persons over the age of 35 or persons with pre-existing health problems. Read all instructions before using. ICON assumes no responsibility for personal injury or property damage sustained by or through the use of this product.

PART LIST—Model No. PFEVEX39910

R1201A

Key No.	Qty.	Description	Key No.	Qty.	Description
1	1	Frame	48	1	Idler Arm
2	1	Front Stabiliser	49	1	Idler Wheel
3	1	Frame Rail	50	1	Backrest Frame Endcap
4	1	Seat Carriage	51	1	1/2" x 70mm Bolt
5	1	Backrest Frame	52	1	1/2" Nylon Locknut
6	1	Seat Frame	53	1	"J" Bolt
7	1	Rear Stabiliser Cover	54	1	Pulley
8	1	Front Stabiliser Cover	55	1	Idler Bolt
9	1	Rear Stabiliser	56	2	Flange Screw
10	1	Backrest	57	1	Right Crank Arm
11	1	Headrest	58	2	M6 Eye Bolt
12	1	Seat	59	2	"U" Bracket
13	1	Upright	60	4	M6 Nut
14	1	Upright Bushing	61	4	M8 Nylon Locknut
15	1	Handgrip Pulse Sensor	62	2	Flywheel Washer
16	1	Console	63	3	M10 Black Nylon Locknut
17	1	Left Side Shield	64	1	Idler Washer
18	1	Right Side Shield	65	2	M10 x 112mm Carriage Bolt
19	1	Side Shield Cover	66	2	M10 Zinc Nylon Locknut
20	2	Seat Carriage Bushing	67	1	"C" Magnet Bolt
21	2	Small Hand Weight	68	2	M10 x 52mm Button Bolt
22	2	Medium Hand Weight	69	3	M6 x 50mm Screw
23	2	Large Hand Weight	70	8	M5 x 6mm Screw
24	1	Left Pedal	71	3	M6 Flat Washer
25	1	Left Pedal Strap	72	5	M4 x 25mm Screw
26	1	Right Pedal	73	6	M4 x 16mm Screw
27	1	Right Pedal Strap	74	2	M10 x 45mm Button Screw
28	2	Adjustment Knob	75	4	M4 x 38mm Screw
29	1	Adjustment Pin	76	3	M10 x 27mm Button Screw
30	2	Wheel	77	3	M10 Black Split Washer
31	1	Left Front Endcap	78	2	M5 Nut
32	1	Right Front Endcap	79	1	M6 x 25.4mm Button Screw
33	2	Levelling Foot	80	2	M6 x 72mm Button Screw
34	1	Adjustment Motor	81	4	M5 x 12mm Screw
35	1	Upper Wire Harness	82	1	Reed Switch Clamp
36	1	Lower Wire Harness	83	2	Push Nut
37	1	Flywheel	84	2	M4 x 12mm Screw
38	1	Magnet	85	2	M10 Zinc Split Washer
39	1	Flywheel Axle	86	4	M5 Nylon Locknut
40	2	Flywheel Bearing	87	5	M6 x 16mm Screw
41	1	"C" Magnet	88	1	M6 x 25mm Bolt
42	1	Left Crank Arm	89	1	Belt
43	1	Reed Switch/Wire	90	1	Snap Ring
44	2	Crank Bearing	91	2	Bushing
45	1	Crank Shaft	#	1	User's Manual
46	1	Adjustment Cable	#	1	Allen Wrench
47	1	Return Spring			

Note: # indicates a non-illustrated part. Specifications are subject to change without notice.

BEFORE YOU BEGIN

Congratulations for selecting the new PROFORM® 970 crosstrainer. The unique PROFORM® 970 combines a comfortable recumbent cycle with a convenient weight bench to let you enjoy both aerobic exercise and strength training exercise in the convenience of your home.

Department at **08457 089 009**. To help us assist you, please note the product model number and serial number before calling. The model number is PFEVEX39910. The serial number can be found on a decal attached to the crosstrainer (see the front cover of this manual for the location of the decal).

For your benefit, read this manual carefully before you use the crosstrainer. If you have questions after reading the manual, please call our Customer Service

Before reading further, please familiarise yourself with the parts that are labelled in the drawing below.

CAUTION: The decals shown below are found on the crosstrainer in the locations indicated above. If a decal is missing or illegible, call 8457 089 009 to order a free replacement decal. Apply the decal in the location shown.

Note: The decals are not shown at actual size.

1 CAUTION

Do not sit on seat-back or headrest. The machine could tip over, causing injury.



2 CAUTION

The bench should be used only with the weights provided.

3 CAUTION

Always position the seat adjustment in the full forward setting before using the bench.

ASSEMBLY

Assembly requires two persons. Place all parts of the crosstrainer in a cleared area and remove the packing materials. Do not dispose of the packing materials until assembly is completed. **In addition to the included allen wrenches, assembly requires a phillips screwdriver** , **an adjustable spanner**  **and a rubber mallet** .

As you assemble the crosstrainer, use the drawings below to identify the small parts used in assembly. The number in parenthesis below each drawing refers to the key number of the part, from the PART LIST on page 22. The second number refers to the quantity used in assembly. **Note: Some small parts may have been pre-assembled for shipping. If a part is not in the parts bag, check to see if it has been pre-assembled.**

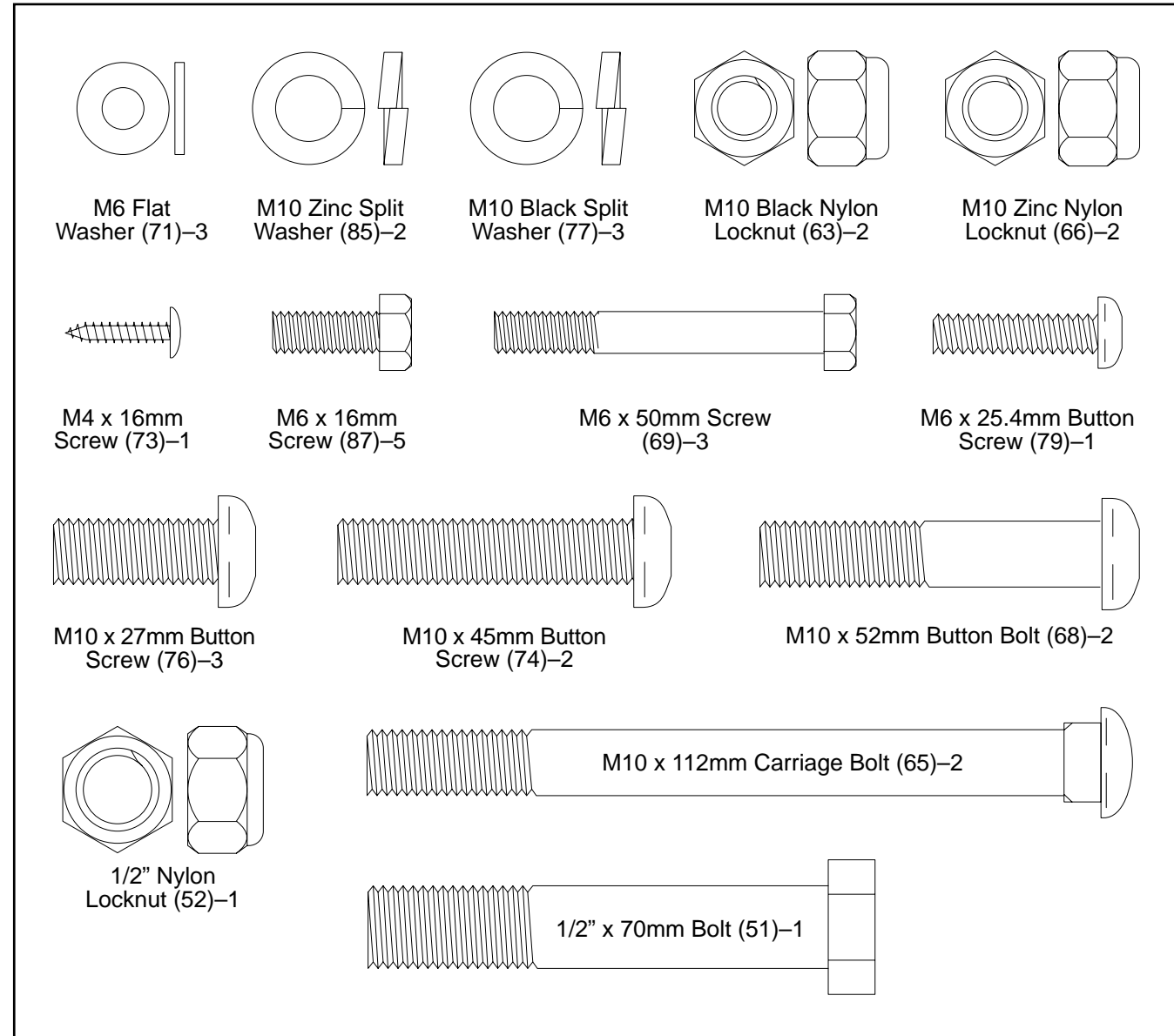

MAINTENANCE AND TROUBLESHOOTING

Inspect and tighten all parts of the crosstrainer regularly. Replace any worn parts immediately.

To clean the crosstrainer, use a damp cloth and a small amount of mild soap. **Important: To avoid damage to the console, keep liquids away from the console and keep the console out of direct sunlight.**

BATTERY REPLACEMENT

If the console display becomes dim, the batteries should be replaced; most console problems are the result of low batteries. Refer to assembly step 9 on page 7 for replacement instructions. Note: The console requires four 1,5 V "D" batteries.

HOW TO LEVEL THE CROSSTRAINER

After the crosstrainer has been moved to the location where it will be used, make sure that both ends of front Stabiliser are touching the floor. If the crosstrainer rocks slightly during use, turn one or both of the Levelling feet under the front Stabiliser until the rocking motion is eliminated.

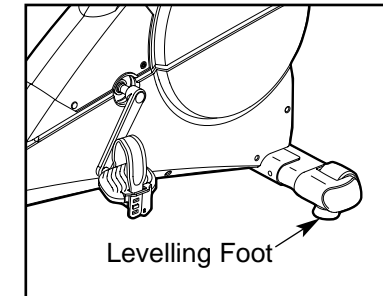

HANDGRIP PULSE SENSOR TROUBLE-SHOOTING

- Avoid moving your hands whilst using the handgrip pulse sensor. Excessive movement may interfere with heart rate readings.

- Do not hold the metal contacts too tightly; doing so may interfere with heart rate readings.
- For the most accurate heart rate reading, hold the metal contacts for about 15 seconds.
- For optimal performance of the handgrip pulse sensor, keep the metal contacts clean. The contacts can be cleaned with a soft cloth—never use alcohol, abrasives, or chemicals.

HOW TO MOVE THE CROSSTRAINER

Before moving the crosstrainer, remove the hand weights and adjust the seat to the position shown in the drawing below. Then, stand behind the crosstrainer, hold the rail in the indicated location, and lift the rail until the crosstrainer can be moved on the front wheels. Carefully move the crosstrainer to the desired location and then lower it. **CAUTION: To decrease the possibility of injury, bend your legs and keep your back straight as you lift the rail and move the crosstrainer; make sure to lift with your legs rather than your back.**

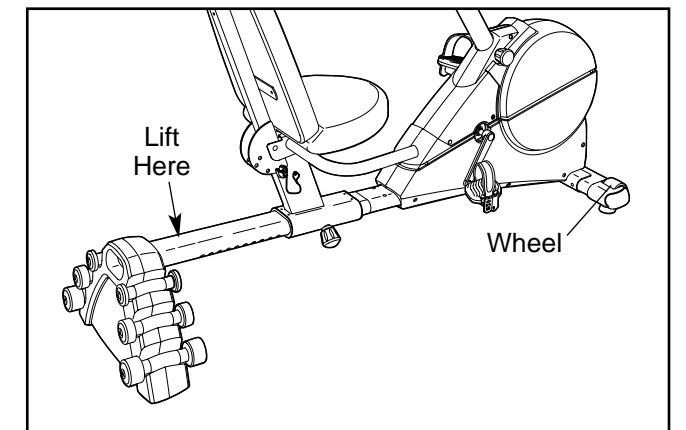

WEIGHT BENCH EXERCISE GUIDELINES

⚠ WARNING: Before beginning any exercise program, consult your physician. This is especially important for persons over the age of 35 or persons with pre-existing health problems.

HOW TO ADJUST THE BACKREST

The backrest can be adjusted to any of four positions: the inclined (upright) position, the semi-inclined position, the flat position, and the declined position.

To adjust the backrest, **first adjust the seat to the farthest forward position** (see HOW TO ADJUST THE SEAT on page 9). Next, pull out the adjustment pin. Pivot the backrest to the desired position, and then insert the pin into one of the holes in the rounded brackets and the corresponding hole in the seat carriage (see the inset drawing). Note: When the backrest is in the declined position, the seat will also be declined. **CAUTION: Never sit on the backrest or the headrest; doing so could cause the crosstrainer to tip, resulting in injury.**

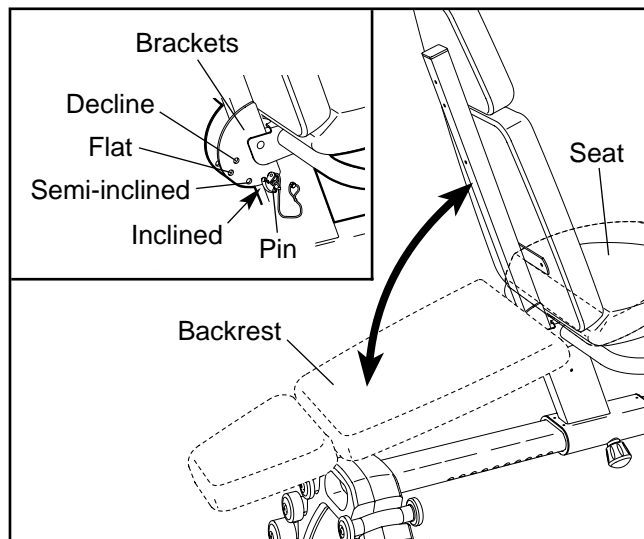

STRENGTH TRAINING GUIDELINES

The weight bench can be used for a variety of exercises designed to trim, tone, and strengthen the body. Please read these guidelines before using the weight bench.

It is recommended that your strength training program include 3 workouts each week. Note: You may wish to use the weight bench and the recumbent cycle on

alternating days. For example, plan weight training workouts on Tuesday, Thursday, and Saturday, and plan aerobic workouts on Monday, Wednesday, and Friday. Make sure to rest for at least one full day each week to give your body time to regenerate. **CAUTION: It is very important to avoid overdoing it during the first few months of your exercise program, and to progress at your own pace.**

Begin each workout with five to eight minutes of stretching and light exercise to warm up. A proper warm-up increases your body temperature, heart rate, and circulation in preparation for exercise.

After warming up, perform a selection of weight training exercises. The chart on the backrest shows four exercises that can be performed. Consult a reputable book to find other exercises that can be performed using hand weights and a weight bench. To give balance to your workouts, vary the exercises from workout to workout. Begin with 1 set of 12 repetitions for each exercise. (A "repetition" is one complete cycle of an exercise, such as one sit-up. A "set" is a series of repetitions performed without a pause.) As your fitness level increases, perform 2 or 3 sets for each exercise. Always rest for at least 1 minute after each set. When you can complete 3 sets of 12 repetitions without difficulty, you may choose to use heavier weights. **CAUTION: The crosstrainer includes three pairs of hand weights. Do not use other weights with the crosstrainer.**

Finish each workout with five to eight minutes of stretching to cool down. This will increase your flexibility and will help to prevent soreness.

EXERCISE FORM

For the best results, correct form is important. Maintaining proper form means moving through the full range of motion for each exercise, and moving only the appropriate parts of the body. Make sure to perform each exercise with a smooth, steady motion. Exhale as you exert yourself, and inhale as you return to the starting position; never hold your breath.

STAYING MOTIVATED

For motivation, try listening to music or watching television whilst you exercise. Use a calendar to keep a record of your workouts, and record key body measurements at the end of every month. Remember, the key to lasting results is to make exercise a regular and enjoyable part of your daily life.

1. Whilst another person lifts the front of the Frame (1) slightly, attach the Front Stabiliser (2) to the Frame with two M10 x 112mm Carriage Bolts (65) and two M10 Black Nylon Locknuts (63). **Make sure that the Front Stabiliser is turned so the Wheels (30) are not touching the floor.**

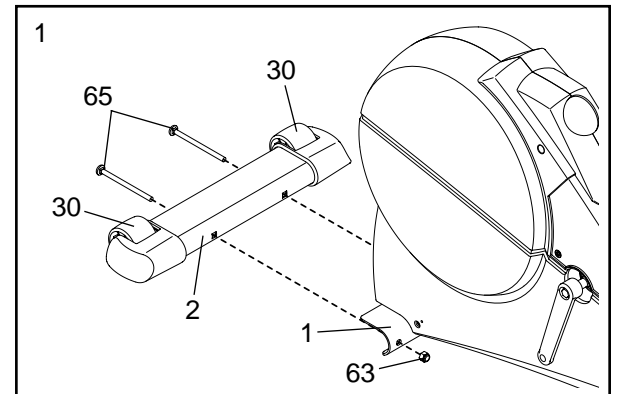

2. Orient the Frame Rail (3) as shown, with the hexagonal holes in the indicated position. Insert the end of the Frame Rail into the Stabiliser Covers (7, 8) as shown. Attach the Stabiliser Covers with two M10 x 45mm Button Screws (74).

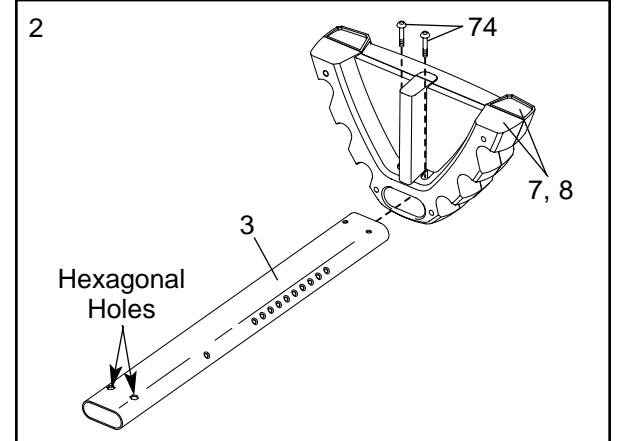

3. Locate the Knob (not shown) on the Seat Carriage (4). Turn the Knob counterclockwise two or three turns to loosen it. Next, pull the Knob, slide the Seat Carriage onto the Frame Rail (3), and then release the Knob. Make sure that the Seat Carriage is oriented as shown. **Move the Seat Carriage back and forth slightly until it locks into position.** Then, tighten the Knob.

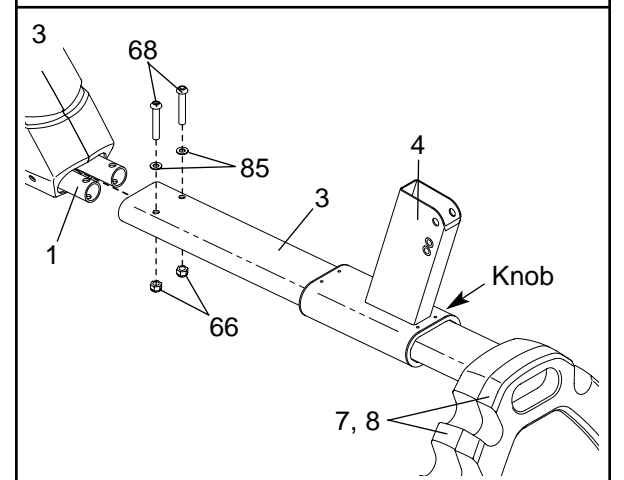

Slide the Frame Rail (3) onto the indicated round tubes on the Frame (1). Attach the Frame Rail with two M10 x 52mm Button Bolts (68), two M10 Zinc Split Washers (85), and two M10 Zinc Nylon Locknuts (66).

Set the six Hand Weights (not shown) on the Stabiliser Covers (7, 8) as shown on page 3.

4. With the help of a second person, slide the Backrest Frame (5) onto the top of the Seat Carriage (4). Next, slide the bracket on the Seat Frame (6) over the rounded brackets on the Backrest Frame. Align the indicated holes in the Seat Frame, the Backrest Frame, and the Seat Carriage, and insert the 1/2" x 70mm Bolt (51) into the holes. Then, tighten the 1/2" Nylon Locknut (52) onto the Bolt.

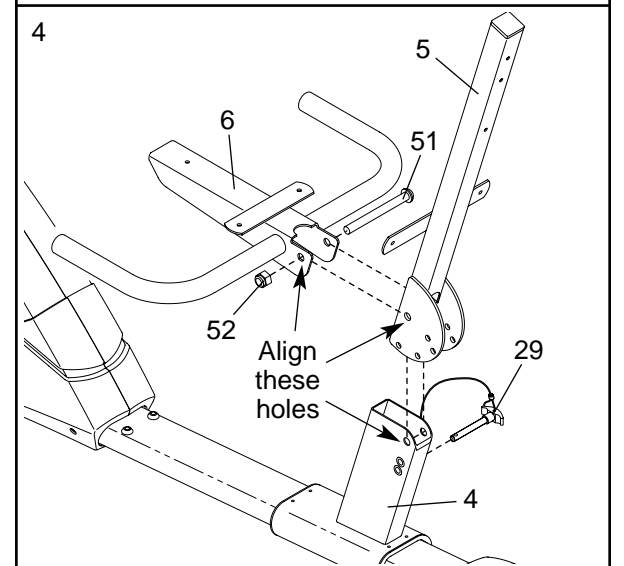

Pivot the Backrest Frame (5) up until it is nearly vertical. Insert the Adjustment Pin (29) into the lowest hole in the rounded brackets on the Backrest Frame and through the corresponding hole in the Seat Carriage (4).

5. Attach the Seat (12) to the Seat Frame (6) with three M6 x 16mm Screws (87).

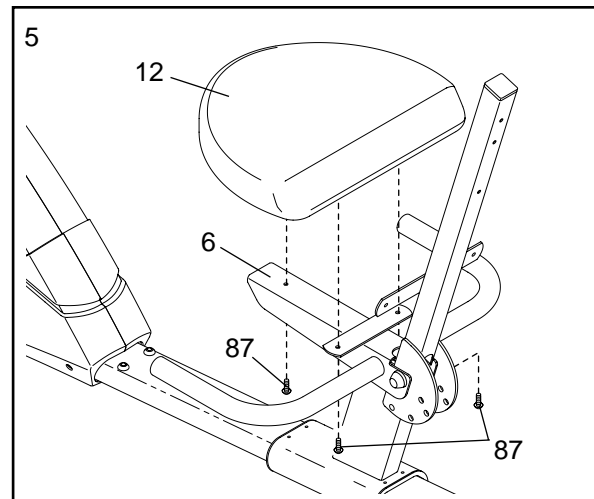

6. Attach the Backrest (10) to the Backrest Frame (5) with two M6 x 16mm Screws (87), an M6 x 50mm Screw (69), and an M6 Flat Washer (71).

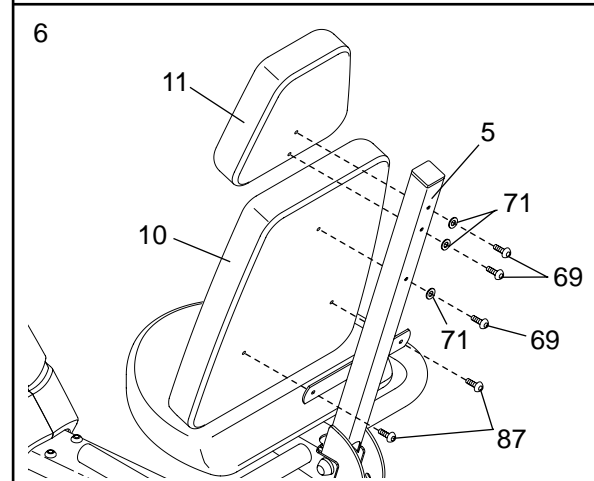

Attach the Headrest (11) to the Backrest Frame (5) with two M6 x 50mm Screws (69) and two M6 Flat Washers (71).

7. Whilst another person holds the Upright (13) in the position shown, connect the Upper Wire Harness (35) to the Lower Wire Harness (36). **Carefully pull the upper end of the Upper Wire Harness to remove any slack from the Wire Harnesses.**

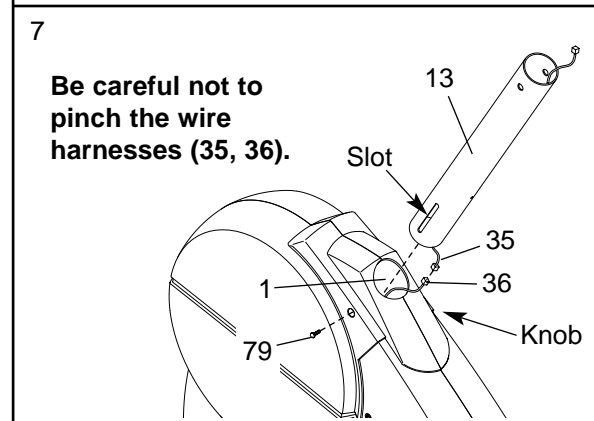

Turn the Knob (not shown) on the right side of the Frame (1) counterclockwise two or three turns to loosen it. Next, pull the Knob, insert the Upright (13) into the Frame, and then release the Knob. **Move the Upright up and down slightly until it locks into position. Be careful to avoid pinching the Wire Harnesses (35, 36).** Tighten the indicated M6 x 25.4mm Button Screw (79) into the slot in the side of the Upright.

8. Connect the wire harness on the Handgrip Pulse Sensor (15) to the indicated wire harness on the Console (16). Insert both wire harnesses into the opening in the bottom of the Console. Then, insert the metal tube on the Handgrip Pulse Sensor into the opening in the bottom of the Console. **Be careful not to pinch the wire harnesses.**

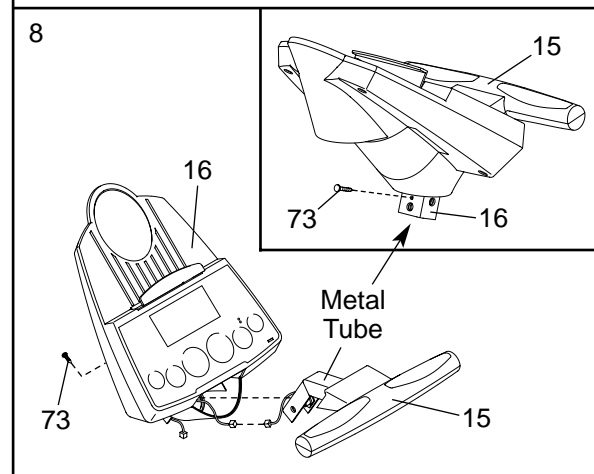

Refer to the inset drawing. Tighten an M4 x 16mm Screw (73) into the indicated bracket on the Console (16) and into the metal tube on the Handgrip Pulse Sensor (15).

RECUMBENT CYCLE EXERCISE GUIDELINES

⚠ WARNING:

Before beginning this or any exercise program, consult your physician. This is especially important for persons over the age of 35 or persons with pre-existing health problems.

The pulse sensor is not a medical device. Various factors may affect the accuracy of heart rate readings. The pulse sensor is intended only as an exercise aid in determining heart rate trends in general.

The following guidelines will help you to plan your workouts using the recumbent cycle. Remember that proper nutrition and adequate rest are essential for successful results.

EXERCISE INTENSITY

Whether your goal is to burn fat or to strengthen your cardiovascular system, the key to achieving the desired results is to exercise with the proper intensity. The proper intensity level can be found by using your heart rate as a guide. The chart below shows recommended heart rates for fat burning, maximum fat burning, and cardiovascular (aerobic) exercise.

165	155	145	140	130	125	115	♥
145	138	130	125	118	110	103	♥
125	120	115	110	105	95	90	♥
20	30	40	50	60	70	80	

To find the proper heart rate for you, first find your age on the bottom line of the chart (ages are rounded off to the nearest ten years). Next, find the three numbers above your age. The three numbers are your “training zone.” The lower two numbers are recommended heart rates for fat burning; the highest number is the recommended heart rate for aerobic exercise.

Fat Burning

To burn fat effectively, you must exercise at a relatively low intensity level for a sustained period of time. During the first few minutes of exercise, your body uses easily accessible carbohydrate calories for energy. Only after the first few minutes of exercise does

your body begin to use stored fat calories for energy. If your goal is to burn fat, adjust the intensity of your exercise until your heart rate is near the lowest number in your training zone as you exercise. For maximum fat burning, adjust the intensity of your exercise until your heart rate is near the middle number in your training zone as you exercise.

Aerobic Exercise

If your goal is to strengthen your cardiovascular system, your exercise must be “aerobic.” Aerobic exercise is activity that requires large amounts of oxygen for prolonged periods of time. This increases the demand on the heart to pump blood to the muscles, and on the lungs to oxygenate the blood. For aerobic exercise, adjust the intensity of your exercise until your heart rate is near the highest number in your training zone as you exercise.

WORKOUT GUIDELINES

Each workout should include the following three parts:

A warm-up, consisting of 5 to 10 minutes of stretching and light exercise. A proper warm-up increases your body temperature, heart rate, and circulation in preparation for exercise.

Training zone exercise, consisting of 20 to 30 minutes of exercising with your heart rate in your training zone. (During the first few weeks of your exercise program, do not keep your heart rate in your training zone for longer than 20 minutes.)

A cool-down, with 5 to 10 minutes of stretching. This will increase the flexibility of your muscles and will help to prevent post-exercise problems.

EXERCISE FREQUENCY

To maintain or improve your condition, plan three workouts on the recumbent cycle each week. After a few months of regular exercise, you may complete up to five workouts each week if desired. Note: You may wish to use the recumbent cycle and the weight bench on alternating days. For example, plan aerobic workouts on Monday, Wednesday, and Friday, and plan weight training workouts on Tuesday, Thursday, and Saturday. Make sure to rest for at least one full day each week to give your body time to regenerate. **CAUTION: It is very important to avoid overdoing it during the first few months of your exercise program, and to progress at your own pace.**

HOW TO USE PROGRAMS DIRECTLY FROM OUR WEB SITE

Our Web site at www.iFIT.com allows you to play iFIT.com audio and video programs directly from the internet. To use programs from our Web site, the crosstrainer must be connected to your home computer. See HOW TO CONNECT YOUR COMPUTER on page 15. In addition, you must have an internet connection and an internet service provider. A list of specific system requirements will be found on our Web site.

Follow the steps below to use a program from our Web site.

1 Turn on the console.

Refer to step 1 on page 12.

2 Select the iFIT.com mode.

Each time the console is turned on, the manual mode will be selected. To select the iFIT.com mode, press the iFIT.com button. The indicator on the button will light and the letters IF will appear in the upper right corner of the display.

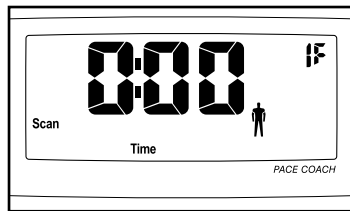

3 Go to your computer and start an internet connection.

4 Start your Web browser, if necessary, and go to our Web site at www.iFIT.com.

5 Follow the desired links on our Web site to select a program.

Read and follow the on-line instructions for using a program.

6 Follow the on-line instructions to start the program.

When you start the program, an on-screen count-down will begin.

7 Return to the crosstrainer and begin exercising.

When the on-screen countdown ends, the program will begin. The program will function in almost the same way as a Smart program (refer to step 3 on page 13). However, an electronic "chirping" sound will alert you when the resistance and/or the target pace is about to change.

8 Follow your progress with the feedback modes.

Refer to step 4 on page 12.

9 Measure your heart rate if desired.

Refer to step 5 on page 12.

10 When you are finished exercising, the console will automatically turn off after five minutes.

Refer to step 6 on page 12.

THE OPTIONAL CHEST PULSE SENSOR

The optional chest pulse sensor provides hands-free operation and continuously monitors your heart rate during your workouts on the recumbent cycle. **To purchase the optional chest pulse sensor, call 08457 089 009.**

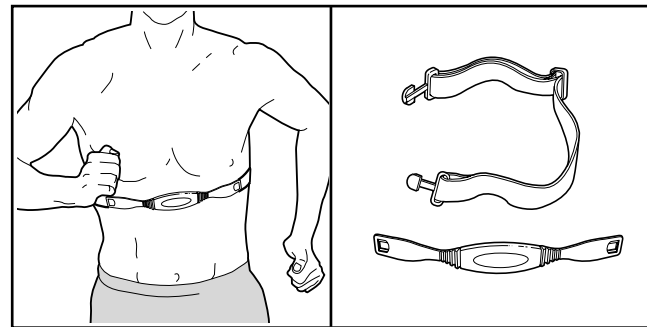

9. The Console (16) requires four 1,5 V "D" batteries; alkaline batteries are recommended. Press the tab on the battery cover, and lift off the battery cover. Insert four batteries into the battery compartment. **Make sure that the batteries are oriented as shown by the diagram inside the battery compartment.** Reattach the battery cover.

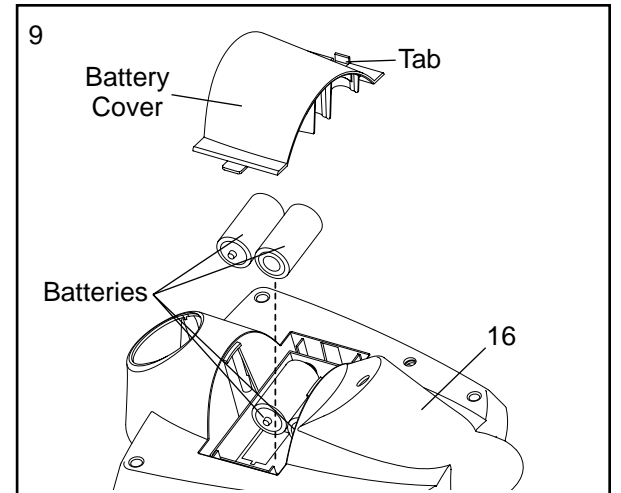

10. Whilst another person holds the Console (16) in the position shown, connect the wire harness on the Console to the Upper Wire Harness (35). Insert the excess wire harness into the Upright (13).

Attach the Console (16) to the Upright (13) with three M10 x 27mm Button Screws (76) and three M10 Black Split Washers (77). **Be careful to avoid pinching the wire harnesses.**

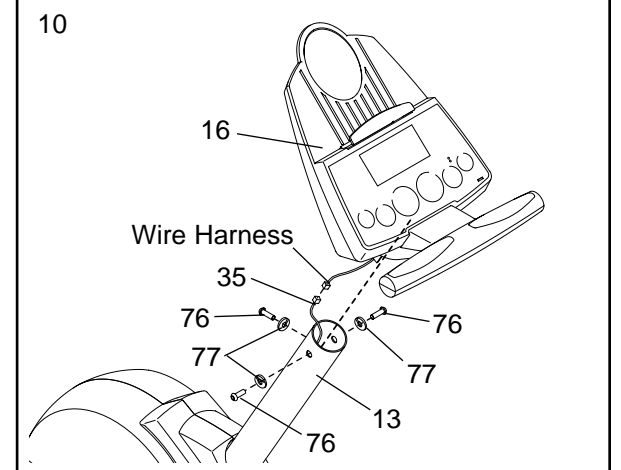

11. Identify the Left Pedal (24), which is marked with an "L." Using an adjustable wrench, **firmly tighten** the Left Pedal counterclockwise into the Left Crank Arm (42). Tighten the Right Pedal (not shown) clockwise into the Right Crank Arm (not shown) in the same way. **Important: Tighten both Pedals as firmly as possible. After using the crosstrainer for one week, retighten the Pedals. For the best performance, the Pedals must be kept properly tightened.**

Adjust the Left Pedal Strap (25) to the desired position and press the end of the Strap onto the tab on the Left Pedal (24). Adjust the Right Pedal Strap (not shown) in the same way.

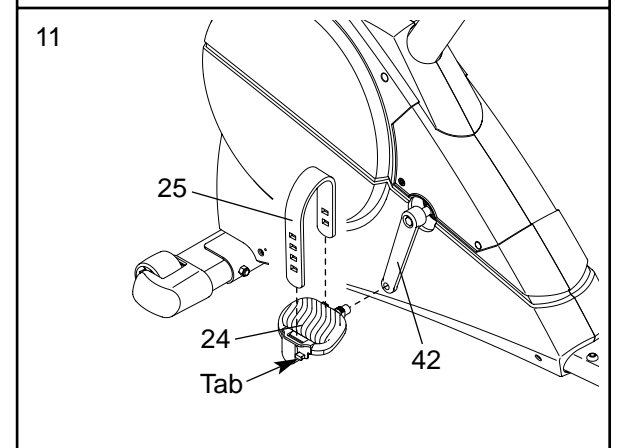

12. **Make sure that all parts of the crosstrainer are properly tightened.** Note: Some hardware may be left over after assembly is completed. To protect the floor or carpet from damage, place a mat under the crosstrainer.

INSTALLING THE RECEIVER FOR THE OPTIONAL CHEST PULSE SENSOR

If you purchase the optional chest pulse sensor (refer to page 18), follow the steps below to install the receiver and the short jumper wire included with the chest pulse sensor.

1. Remove the four indicated screws from the back of the Console (16). Lift off the front of the Console.

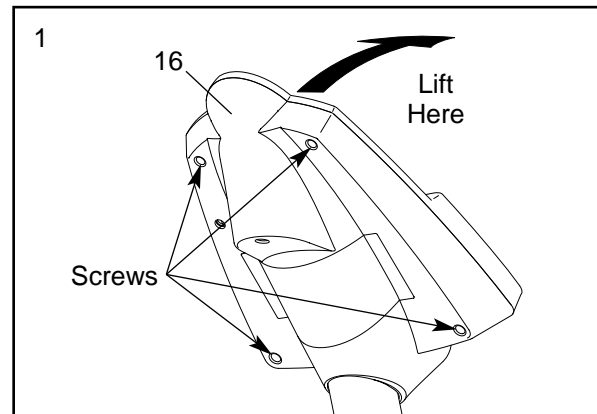

2. Plug the short jumper wire (A) into the indicated jack on the Console (16). Connect the other end of the short jumper wire to the wire on the receiver (B). **Note: The included long jumper wire is not needed.**

Next, peel the paper off the adhesive pad on the back of the receiver (B). Orient the receiver as shown, and press it onto the Console (16) in the indicated location.

Refer to step 1 above. Reattach the front of the Console (16) with the four screws. **Make sure that no wires are pinched.**

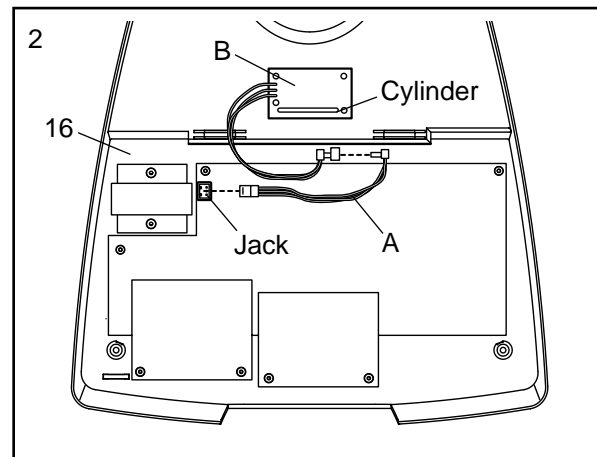

HOW TO USE iFIT.COM CD AND VIDEO PROGRAMS

To use iFIT.com CDs or videocassettes, the crosstrainer must be connected to your portable CD player, portable stereo, home stereo, computer with CD player, or VCR. See HOW TO CONNECT YOUR CD PLAYER, VCR, OR COMPUTER on page 14. **For information about the availability of iFIT.com CD's or videocassettes, send an e-mail to workouts@iFIT.com, and we'll notify you as soon as iFIT.com CD's and videocassettes are available.**

Follow the steps below to use an iFIT.com CD or video program.

- 1 Turn on the console.

Refer to step 1 on page 12.

- 2 Select the iFIT.com mode.

Each time the console is turned on, the manual mode will be selected. To select the iFIT.com mode, press the iFIT.com button. The indicator on the button will light and the letters IF will appear in the upper right corner of the display.

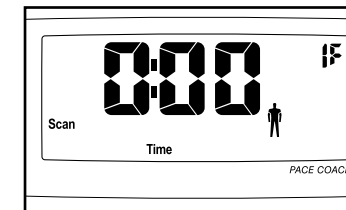

- 3 Insert the iFIT.com CD or videocassette.

If you are using an iFIT.com CD, insert the CD into your CD player. If you are using an iFIT.com videocassette, insert the videocassette into your VCR.

- 4 Press the play button on your CD player or VCR.

A moment after the play button is pressed, your personal trainer will begin guiding you through your workout. Simply follow your personal trainer's instructions.

The program will function in almost the same way as a Smart program (refer to step 3 on page 13). However, an electronic "chirping" sound will alert you when the resistance and/or the target pace is about to change.

Note: If the resistance and/or the target pace does not change when a "chirp" is heard:

- Make sure that the indicator on the iFIT.com button is lit.
- Adjust the volume of your CD player or VCR. If the volume is too high or too low, the console may not detect the program signals.
- Make sure that the audio cable is properly connected and that it is fully plugged in.

- 5 Follow your progress with the feedback modes.

Refer to step 4 on page 12.

- 6 Measure your heart rate if desired.

Refer to step 5 on page 12.

- 7 When you are finished exercising, the console will automatically turn off after five minutes.

Refer to step 6 on page 12.

HOW TO CONNECT YOUR VCR

Note: If your VCR has an unused AUDIO OUT jack, see instruction A below. If the AUDIO OUT jack is being used, see instruction B. If you have a TV with a built-in VCR, see instruction B. If your VCR is connected to your home stereo, see HOW TO CONNECT YOUR HOME STEREO on page 15.

A. Plug one end of the audio cable into the jack beneath the console. Plug the other end of the audio cable into the adaptor. Plug the adaptor into the AUDIO OUT jack on your VCR.

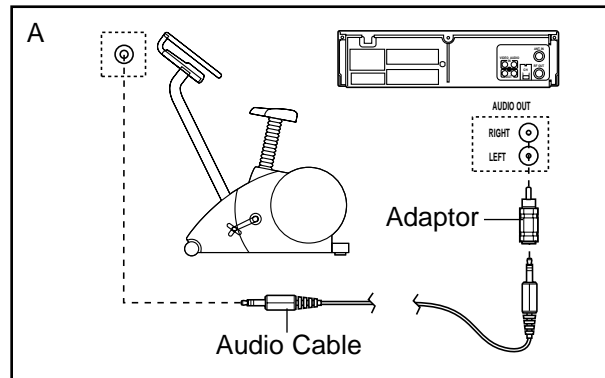

B. Plug one end of the audio cable into the jack beneath the console. Plug the other end of the audio cable into the adaptor. Plug the adaptor into an RCA Y-adaptor (available at electronics stores). Next, remove the wire that is currently plugged into the AUDIO OUT jack on your VCR and plug the wire into the unused side of the Y-adaptor. Plug the Y-adaptor into the AUDIO OUT jack on your VCR.

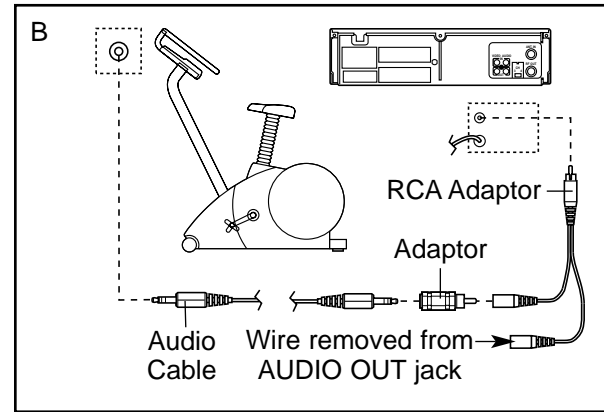

HOW TO USE THE RECUMBENT CYCLE

The crosstrainer features a recumbent cycle for aerobic exercise, and a convenient weight bench for strength training exercise. To use the recumbent cycle, refer to pages 9 to 19. To use the weight bench, refer to page 20.

HOW TO ADJUST THE BACKREST

When the recumbent cycle is used, the backrest should be in the upright position. To adjust the backrest, first pull out the adjustment pin. Raise the backrest until it is nearly vertical, and then insert the adjustment pin into the indicated hole in the rounded brackets and the corresponding hole in the seat carriage.

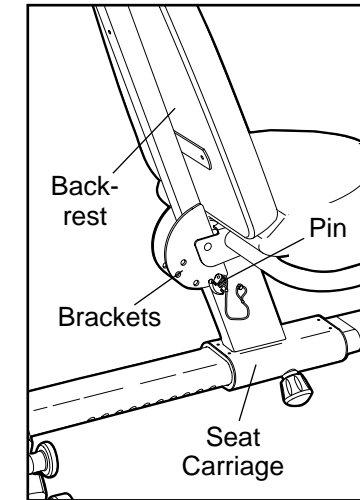

HOW TO ADJUST THE SEAT

For effective exercise, the seat should be in the proper position. As you pedal, there should be a slight bend in your knees when the pedals are in the farthest position. To adjust the seat, first turn the indicated adjustment knob counterclockwise two or three turns to loosen it (if the knob is not loosened enough, it may scratch the rail). Next, pull the knob, slide the seat carriage to the desired position, and then release the knob. **Move the seat carriage back and forth slightly until it locks into position.** Then, turn the knob clockwise until it is tight.

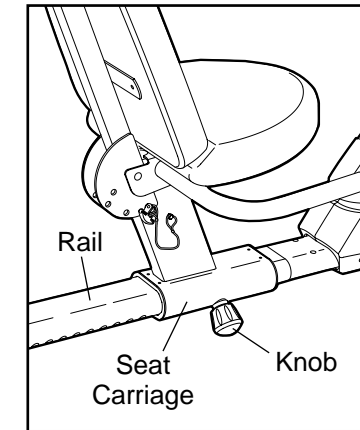

HOW TO ADJUST THE UPRIGHT

The upright can be adjusted to the height that is the most comfortable for you. To adjust the upright, first turn the indicated adjustment knob counterclockwise two or three turns to loosen it (if the knob is not loosened enough, it may scratch the upright). Next, pull the knob, slide the upright to the desired height, and then release the knob. **Move the upright up and down slightly until it locks into position.** Then, turn the knob clockwise until it is tight. **IMPORTANT: After you adjust the upright, make sure that your knees will not touch the handgrip pulse sensor when you pedal.**

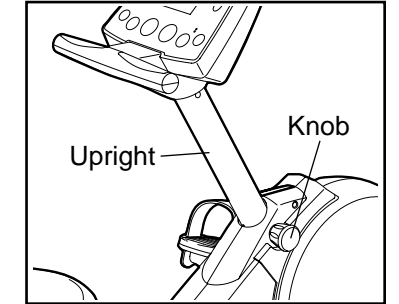

HOW TO ADJUST THE PEDAL STRAPS

To adjust the pedal straps, first pull the ends of the straps off the tabs on the pedals. Adjust the straps to the desired positions, and then press the ends of the straps back onto the tabs.

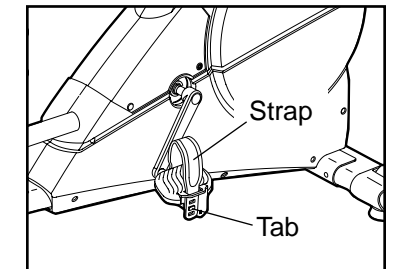

HOW TO USE THE HAND WEIGHTS

The included hand weights can be used for a variety of strength training exercises with the weight bench (refer to page 20). In addition, the hand weights can be used with the recumbent cycle. As you pedal, press the hand weights over your head, raise the hand weights out to your sides until your hands are level with your shoulders, or do arm curls with the hand weights.

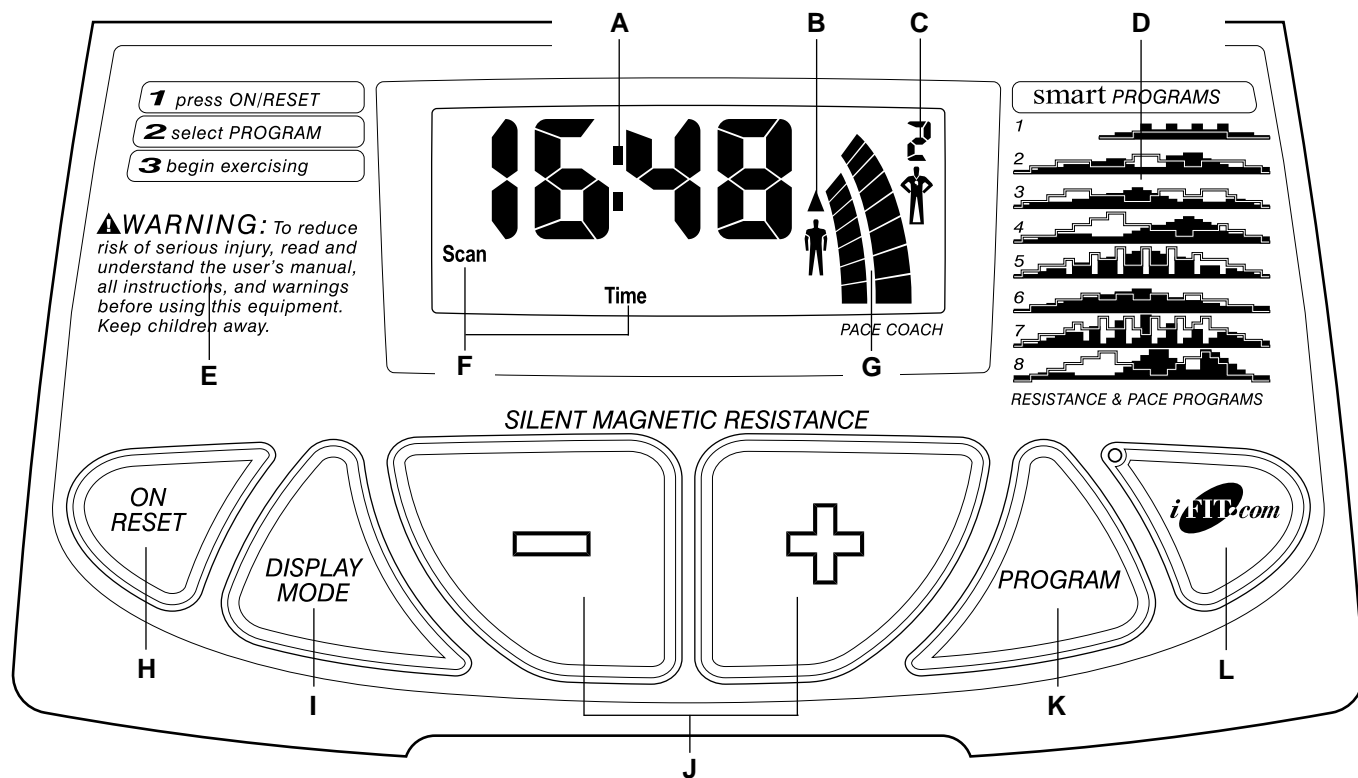

FEATURES OF THE CONSOLE

The advanced console offers a selection of features designed to make your workouts more enjoyable and effective. When the manual mode of the console is selected, the resistance of the crosstrainer can be adjusted with a touch of a button. As you exercise, the console will provide continuous exercise feedback. You can even measure your heart rate using the built-in handgrip pulse sensor. (For information about an optional chest pulse sensor, refer to page 18.)

The console also offers eight Smart workout programs. Each program automatically changes the resistance of the crosstrainer and prompts you to increase or decrease your pace as it guides you through an effective workout.

The console also features new iFIT.com interactive technology. iFIT.com technology is like having a personal trainer right in your home. Using a stereo audio cable, you can connect the crosstrainer to your home stereo, portable stereo, or computer and play special iFIT.com CD programs (CD's are available separately).

iFIT.com CD programs automatically control the resistance of the crosstrainer and prompt you to vary your pace as a personal trainer coaches you through every step of your workout. High-energy music provides added motivation. Each CD features two programs designed by certified personal trainers.

In addition, you can connect the crosstrainer to your VCR and TV and play iFIT.com video programs (video-cassettes are available separately). Video programs offer the same benefits as iFIT.com CD programs, but add the excitement of working out with a class and an instructor.

With the crosstrainer connected to your computer, you can also go to our new Web site at www.iFIT.com and access audio programs and video programs directly from the internet.

For information about the availability of iFIT.com CD's or videocassettes, send an e-mail to workouts@iFIT.com, and we'll notify you as soon as iFIT.com CD's and videocassettes are available.

HOW TO CONNECT YOUR HOME STEREO

Note: If your stereo has an unused LINE OUT jack, see instruction A below. If the LINE OUT jack is being used, see instruction B.

- A. Plug one end of the audio cable into the jack beneath the console. Plug the other end of the audio cable into the adaptor. Plug the adaptor into the LINE OUT jack on your stereo.

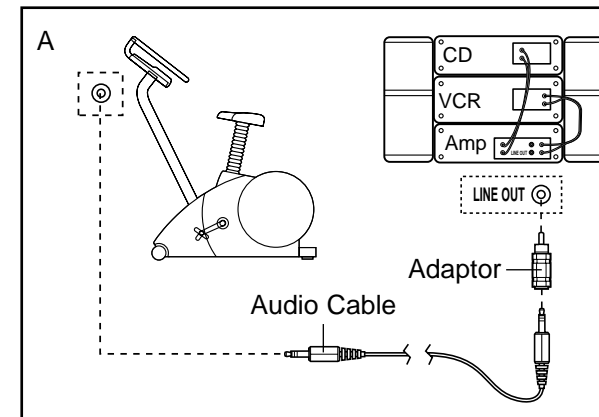

- B. Plug one end of the audio cable into the jack beneath the console. Plug the other end of the audio cable into the adaptor. Plug the adaptor into an RCA Y-adaptor (available at electronics stores). Next, remove the wire that is currently plugged into the LINE OUT jack on your stereo and plug the wire into the unused side of the Y-adaptor. Plug the Y-adaptor into the LINE OUT jack on your stereo.

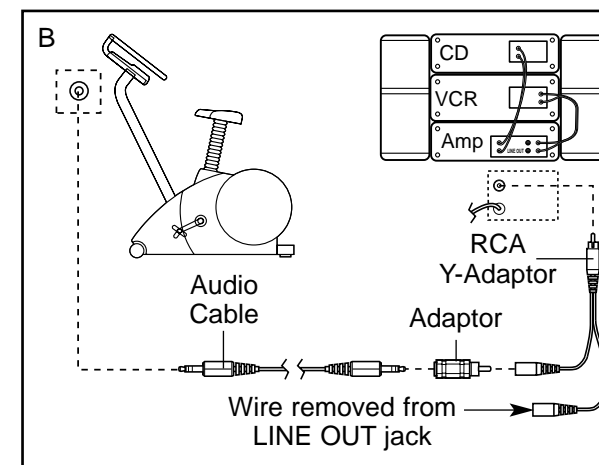

HOW TO CONNECT YOUR COMPUTER

Note: If your computer has a 3.5mm LINE OUT jack, see instruction A. If your computer has only a PHONES jack, see instruction B.

- A. Plug one end of the audio cable into the jack beneath the console. Plug the other end of the audio cable into the LINE OUT jack on your computer.
B. Plug one end of the audio cable into the jack

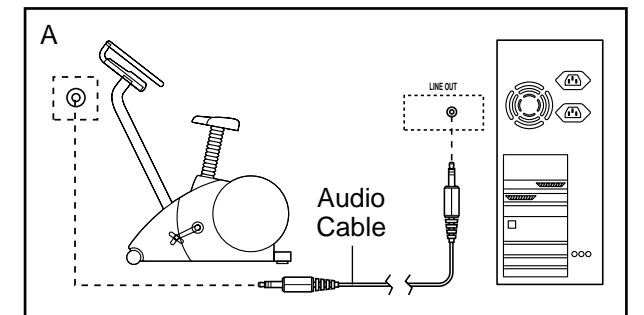

beneath the console. Plug the other end of the audio cable into the splitter. Plug the splitter into the PHONES jack on your computer. Plug your headphones or speakers into the other side of the splitter.

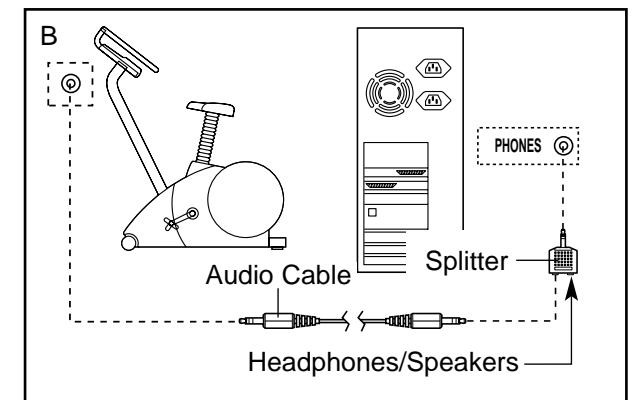

HOW TO CONNECT YOUR CD PLAYER, VCR, OR COMPUTER

To use iFIT.com CD's, the crosstrainer must be connected to your portable CD player, portable stereo, home stereo, or computer with CD player. See pages 14 and 15 for connecting instructions. To use iFIT.com videocassettes, the crosstrainer must be connected to your VCR. See page 16 for connecting instructions. To use iFIT.com programs directly from our Web site, the crosstrainer must be connected to your home computer. See page 15 for connecting instructions.

HOW TO CONNECT YOUR PORTABLE CD PLAYER

Note: If your CD player has separate LINE OUT and PHONES jacks, see instruction A below. If your CD player has only one jack, see instruction B.

- A. Plug one end of the audio cable into the jack beneath the console. Plug the other end of the audio cable into the LINE OUT jack on your CD player. Plug your headphones into the PHONES jack.

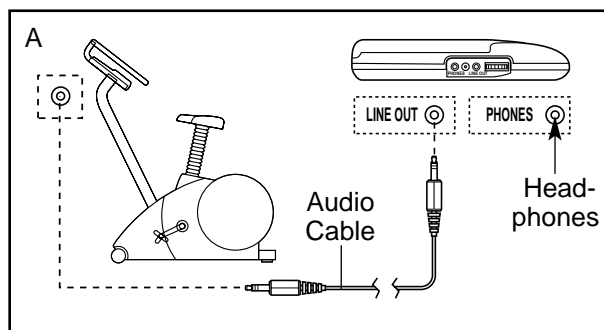

- B. Plug one end of the audio cable into the jack beneath the console. Plug the other end of the audio cable into the splitter. Plug the splitter into the PHONES jack on your CD player. Plug your headphones into the other side of the splitter.

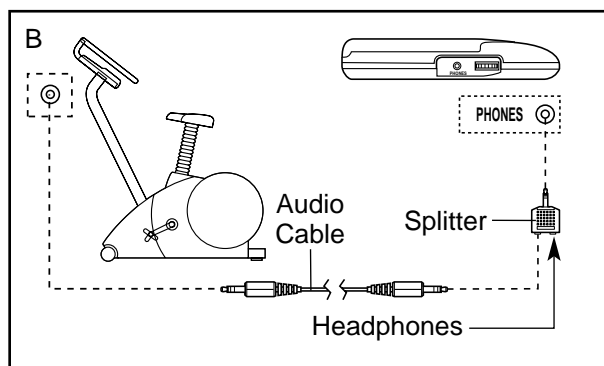

HOW TO CONNECT YOUR PORTABLE STEREO

Note: If your stereo has an RCA-type AUDIO OUT jack, see instruction A below. If your stereo has a 3.5mm LINE OUT jack, see instruction B. If your stereo has only a PHONES jack, see instruction C.

- A. Plug one end of the audio cable into the jack beneath the console. Plug the other end of the audio cable into the adaptor. Plug the adaptor into an AUDIO OUT jack on your stereo.

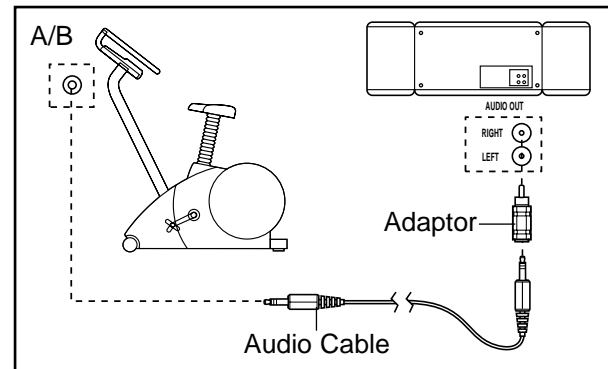

- B. Refer to the drawing above. Plug one end of the audio cable into the jack beneath the console. Plug the other end of the audio cable into the LINE OUT jack on your stereo. Do not use the adaptor.

- C. Plug one end of the audio cable into the jack beneath the console. Plug the other end of the audio cable into the splitter. Plug the splitter into the PHONES jack on your stereo. Plug your headphones into the other side of the splitter.

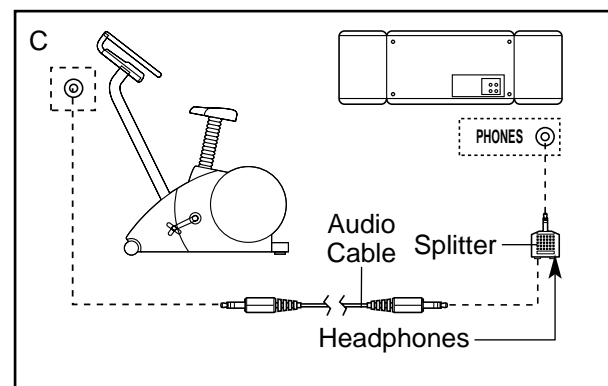

CONSOLE DESCRIPTION

Refer to the drawing on page 10. **Note:** If there is a thin sheet of clear plastic on the face of the console, remove it.

- A. Exercise feedback display—This display features seven modes that give you instant exercise feedback: your current speed, the elapsed time (or the time remaining in a Smart program), the distance that you have pedaled, the resistance level, the approximate number of calories you have burned, the approximate number of fat calories you have burned (see FAT BURNING on page 19), and your heart rate (when you use the handgrip pulse sensor or the optional chest pulse sensor [refer to page 18 for information about the chest pulse sensor]). If the scan mode is selected, the display will change from one mode to the next every six seconds. Or, you can select a single mode for continuous display.

Note: The console can show speed and distance in either miles or kilometres. To change the unit of measurement, hold down the On/Reset button for six seconds. The mode indicators (see F below) will show which unit of measurement is selected. When the batteries are replaced, it may be necessary to reselect the desired unit of measurement.

- B. Increase and decrease arrows—During Smart programs and iFIT.com programs, these arrows will prompt you to increase or decrease your pace to match the target pace.

- C. Manual mode/program indicators—When a Smart program is selected, the upper right corner of the display will show a 1, 2, 3, 4, 5, 6, 7, or 8, depending on which Smart program is selected. When the iFIT.com mode is selected, the upper right corner will show the letters IF. When the manual mode is selected, the upper right corner will be blank.

- D. Program profiles—These profiles show how the resistance of the exercise cycle and the target pace will change during Smart programs. For example, profile number 6 shows that during Smart program 6, the resistance will gradually increase during the first half of the program, and then gradually decrease during the last half; the target pace will alternately increase and decrease throughout the program.

- E. Warnings—See page 3.

- F. Feedback mode indicators—These indicators show

which feedback mode (scan, speed, time, distance, resistance level, calories, fat calories, or heart rate) is currently shown. **Note:** When the distance is shown, the word Miles or the letters Kms will appear; when your speed is shown, the letters MPH or Km/H will appear.

- G. Pace indicators—When the manual mode is selected, only the left pace indicator will appear. This indicator shows your exercise pace. As you increase or decrease your pace, the indicator will increase or decrease in height. When a Smart program or the iFIT.com mode is selected, both pace indicators will appear. The left indicator will show your actual exercise pace, and the right indicator will show the current target pace. During the program, the target pace will periodically change; as the right indicator changes in height, simply adjust your pace so that both indicators are at the same height. **Important:** The target pace is a goal pace. Your actual pace may be slower than the target pace, especially during the first few months of your exercise program. Make sure to exercise at a pace that is comfortable for you.

- H. On/Reset button—When the console is off, pressing this button will turn on the display. When the console is on, pressing this button will reset the display. This button is also used to select the unit of measurement for speed and distance (see A at the left).

- I. Display Mode button—This button is used to select the feedback modes. The modes will be selected in the following order: scan, speed, time, distance, resistance level, calories, fat calories, and heart rate (when the handgrip pulse sensor or the optional chest pulse sensor is used).

- J. + and – buttons—These buttons control the resistance of the exercise cycle. There are ten resistance levels; level 10 is the most challenging.

- K. Program button—This button is used to select the manual mode and Smart programs.

- L. iFIT.com button—This button is used to select the iFIT.com mode. The indicator on the button will light when the iFIT.com mode is selected.

To use the manual mode of the console, refer to page 12. To use a Smart program, refer to page 13. To use iFIT.com CDs or videos, refer to page 17. To use a program directly from our Web site, refer to page 18.

HOW TO USE THE MANUAL MODE

1 Turn on the console.

Note: The console requires four 1,5 V “D” batteries. If you have not installed batteries, refer to step 9 on page 7 and install batteries.

To turn on the console, press the On/Reset button or begin pedalling.

2 Select the manual mode.

Each time the console is turned on, the manual mode will be selected. If a Smart program or the iFIT.com mode

has been selected, select the manual mode by pressing the Program button repeatedly until the upper right corner of the display is blank.

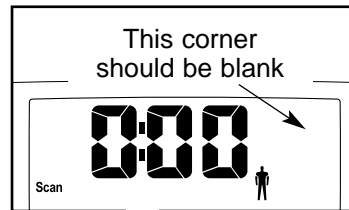

3 Begin exercising and adjust the resistance of the crosstrainer.

As you exercise, adjust the resistance of the crosstrainer as desired by pressing the + and – buttons. There are ten resistance levels; level 10 is the most challenging. Note: After the buttons are pressed, it will take a few seconds for the selected setting to be reached.

4 Follow your progress with the feedback modes and the left bar graph.

When the console is turned on, the scan mode will be selected. As you exercise, the display will show your current speed, the elapsed time, the distance that you have pedalled, the current resistance level, and the approximate number of calories, and the approximate number of fat calories you have burned (see FAT BURNING on page 19). In addition, your heart rate will be shown when you use the handgrip pulse sensor (refer to step 5 at the right) or the optional chest pulse sensor (refer to page 18). Note: Each time the resistance level changes, the console will show the resistance level for six seconds. When a Smart program is

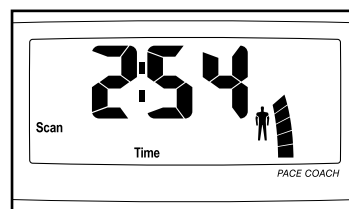

selected, the display will show the time remaining in the program instead of the elapsed time.

In addition, the left pace indicator will appear in the display to show your exercise pace. As you increase or decrease your pace, the indicator will increase or decrease in height.

If desired, you can select a single feedback mode for continuous display. Press the Display Mode button repeatedly until only the MPH (or Km/H), Time, Miles (or Kms), Resist., Cals., or Fat Cals. indicator appears in the display. Make sure that the Scan indicator does not appear.

5 Measure your heart rate if desired.

Note: If you wear the optional chest pulse sensor and hold the handgrip pulse sensor at the same time, the console may not display your heart rate accurately.

If there are thin sheets of plastic on the metal contacts on the handgrip pulse sensor, peel off the plastic.

To use the handgrip pulse sensor, place your hands on the metal contacts. Your palms must be on the upper contacts and your fingers must be touching the lower contacts. Avoid moving your hands. When your pulse is detected, the heart-shaped indicator in the display will flash each time your heart beats. After a moment, two dashes (– –) will appear and then your heart rate will be shown.

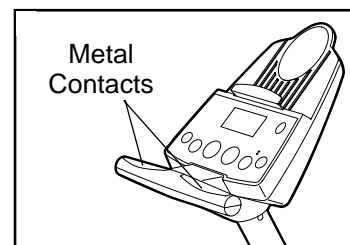

For the most accurate heart rate reading, continue to hold the handgrips for about 15 seconds. Note: When you first hold the handgrips, the display will show your heart rate continuously for 15 seconds. The display will then show your heart rate along with the other feedback modes.

6 When you are finished exercising, the console will automatically turn off after five minutes.

If the pedals are not moved and the console buttons are not pressed for five minutes, **the console will automatically turn off to conserve the batteries.**

HOW TO USE A SMART PROGRAM

1 Turn on the console.

Refer to step 1 on page 12.

2 Select one of the eight Smart programs.

Each time the console is turned on, the manual mode will be selected. To select a Smart program, press the Program button repeatedly until the number 1, 2, 3, 4, 5, 6, 7, or 8 appears in the upper right corner of the display.

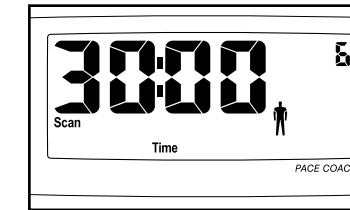

The profiles on the right side of the console show how the resistance of the crosstrainer and the target pace will change during the Smart programs. For example, profile number 6 shows that during Smart program 6, the resistance will gradually increase during the first half of the program, and then gradually decrease during the last half; the target pace will alternately increase and decrease throughout the program.

3 Start the program.

To start the program, simply begin exercising. Each Smart program consists of either twenty or thirty, one-minute periods. One resistance setting and one pace setting are programmed for each period. (The same resistance setting and/or pace setting may be programmed for consecutive periods.)

During the program, the resistance of the crosstrainer will automatically change as shown by the applicable profile on the console. If the current resistance level is too high or too low, you

can change the resistance level by pressing the + and – buttons. However, when the current period of the program is completed, the resistance level will automatically change if a different resistance setting is programmed for the next period.

The target pace settings for the program will be shown by the right pace indicator in the display. (The left indicator will show your actual exercise pace.)

As the right indicator changes in height during the program, simply adjust your pace so that both indicators are at the same height. If your pace is slower than the current target pace, the increase arrow will appear in the display to prompt you to increase your pace; if your pace is faster than the target pace, the decrease arrow will appear. **Important: The target pace settings for the program are intended only to provide a goal. Your actual pace may be slower than the target pace settings, especially during the first few months of your exercise program. Make sure to exercise at a pace that is comfortable for you.**

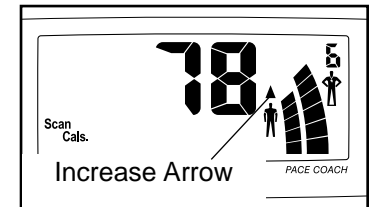

During the program, the display will show the time remaining in the program. If you continue exercising after the program is completed, the display will continue to show your exercise feedback.

4 Follow your progress with the feedback modes.

Refer to step 4 on page 12.

5 Measure your heart rate if desired.

See step 5 on page 12.

6 When you are finished exercising, the console will automatically turn off after five minutes.

Refer to step 6 on page 12.