



Effective Five Slot ATCA AC Shelf User Manual

Table of Contents

TABLE OF CONTENTS	II
TABLE OF FIGURES	V
LEGAL NOTICE AND WARRANTY	VI
CONTACT INFORMATION	VII
SAFETY INSTRUCTIONS.....	VIII
REVISION HISTORY.....	X
ABOUT THIS DOCUMENT.....	XI
1 INTRODUCTION	13
1.1 OVERVIEW OF ASIS SHELF PRODUCTS	13
1.2 ATCA AC SHELF.....	13
2 UNDERSTANDING THE SHELF COMPONENTS	13
2.1 PLATFORM COMPONENTS.....	14
2.1.1 <i>Shelf and Boards.....</i>	<i>14</i>
<i>Fixed Board.....</i>	<i>17</i>
<i>Removable Boards</i>	<i>17</i>
2.1.2 <i>Card Cage.....</i>	<i>17</i>
2.1.3 <i>Backplane</i>	<i>18</i>
<i>Features</i>	<i>18</i>
<i>Update-Channel Connections.....</i>	<i>19</i>
<i>Synchronization Clock Interface.....</i>	<i>19</i>
2.1.4 <i>Module Slot Identification.....</i>	<i>20</i>
2.1.5 <i>AC Power Supply.....</i>	<i>21</i>
<i>Grounding Requirements and Power Input.....</i>	<i>22</i>
2.1.6 <i>Fan Tray</i>	<i>22</i>
2.1.7 <i>Air Filter Tray</i>	<i>23</i>
2.1.8 <i>Blank Panels with/without air baffles</i>	<i>24</i>
2.1.9 <i>Shelf ID Board</i>	<i>24</i>
2.1.10 <i>Holder for Cable Management (Optional).....</i>	<i>25</i>
2.2 SHELF COOLING.....	26
2.2.1 <i>Overview</i>	<i>26</i>
2.2.2 <i>Fan Tray Design.....</i>	<i>26</i>
2.2.3 <i>Performance.....</i>	<i>27</i>

2.2.4	Fan Speed	27
2.2.5	Rear connection boards.....	27
3	INSTALLING THE SHELF	28
3.1	TOOLS REQUIRED	28
3.2	SITE PLANNING.....	28
3.3	CHECKING PACKAGE CONTENTS.....	29
3.4	INSTALLATION STEPS	29
3.5	RACK MOUNTING	29
3.5.1	Shelf Grounding	30
3.5.2	Installer Grounding.....	30
3.6	SHELF APPLICATION CARD INSERTION	31
3.7	REDUNDANT MODULE INSTALLATION	31
3.7.1	Redundant Shelf Manager Card Installation.....	31
4	MAINTENANCE AND TROUBLESHOOTING	32
4.1	PERFORMING PERIODIC MAINTENANCE.....	32
4.1.1	Fan Tray Visual Inspection.....	32
4.1.2	Air Filter Cleaning And Replacement.....	32
4.2	HANDLING ELECTROMAGNETIC INTERFERENCE	33
4.3	EXTRACTING MODULES	34
4.3.1	FRU Module Extraction	34
4.3.2	FRU Module insertion	34
4.3.3	Shelf manager insertion	34
4.3.4	Shelf manager Extraction	34
4.3.5	Power Supply Extraction.....	34
4.3.6	Power Supply insertion.....	35
4.3.7	Fan Tray Replacement.....	35
4.3.8	E ² PROM Replacement	36
4.3.9	Third-Party-Module Replacement.....	36
4.4	HANDLING ALARMS	37
4.4.1	Visual Alarms.....	37
4.4.2	Software Alarms.....	38
4.5	HOT-SWAPPING FRUS	38
4.6	RESETTING THE SYSTEM	39
4.7	TROUBLESHOOTING	40

5	SYSTEM SPECIFICATIONS	41
5.1	CERTIFICATION.....	41
5.2	TECHNICAL DATA	41
5.3	ACRONYMS USED IN THIS MANUAL.....	44

Table of Figures

FIGURE 1 – SHELF BLOCK DIAGRAM	15
FIGURE 2 – SHELF FRONT VIEW	15
FIGURE 3 – SHELF REAR VIEW.....	16
FIGURE 4 – SHELF CHASSIS WITH CABLE HOLDERS	16
FIGURE 5 - SHELF COMPONENT POSITIONING	17
FIGURE 6 – SYNCHRONIZATION CLOCK AND UPDATE CHANNEL PIN ASSIGNMENTS	19
FIGURE 7 - BACKPLANE LAYOUT	20
FIGURE 8 – SLOT ALLOCATIONS	20
FIGURE 9 - SHELF ADDRESSING.....	21
FIGURE 10 – ATCA 1200W AC POWER SUPPLY	21
FIGURE 11 – PS DISTRIBUTION OF POWER ON SHELF	22
FIGURE 12 – FAN TRAY	23
FIGURE 13 – AIR FILTER TRAY	23
FIGURE 14 - BLANK BOARD PANEL AND BLANK RTM PANEL	24
FIGURE 15 - SHELF ID BOARD WITH TWO E ² PROMs (REAR COVER REMOVED).....	25
FIGURE 16 - FAN TRAY.....	26
FIGURE 17 - REAR GROUNDING SCREWS.....	30
FIGURE 18 - FRONT ESD SOCKET.....	31
FIGURE 19 – SHELF AIR FILTER AND POWER SUPPLY AIR FILTER EXTRACTION.....	33
FIGURE 20 – EXTRACTING A FAN TRAY	35

Legal Notice and Warranty

Information in this document is provided in connection with Asis products. no license, express or implied, by estoppel or otherwise, to any intellectual property rights is granted by this document. except as provided in Asis terms and conditions of sale for such products, Asis assumes no liability whatsoever, and Asis disclaims any expressed or implied warranty, relating to sale and/or use of asis products including liability or warranties relating to fitness for a particular purpose, merchant ability, or infringement of any patent, copyright or other intellectual property right.

Asis warranty will be for the quality of the Asis Effective 2-Slot ATCA Shelf for a period of one year after the shipment of the product.

Asis may make changes to the specifications and/or product descriptions at any time, without notice.

ASIS © Ltd. 2007

Contact Information

To order the product described in this document and related systems and components, contact an ASIS representative at:

Israel Headquarters

3 Galgalei Haplada St.

Kfar Saba, ISRAEL 44422

Telephone: **+972-73-233-6633**

Fax: **+972-73-233-6634**

E-mail: sales@asis-pro.com

North America Headquarters

11067 Caminito Arcada

San Diego, CA, 92131 USA

Telephone: 858 776-1421

E-mail: salesns@asis-pro.com

See the ASIS web site at <http://www.asis-pro.com> .

Safety Instructions



This symbol indicates potential safety hazards regarding product operation or maintenance to operator or service personnel.

General Safety Practices

Before handling the board, read the instructions and safety guidelines on the following pages to prevent damage to the product and to ensure your own personal safety.

- Always use caution when handling/operating the board. Only qualified, experienced, authorized electronics service personnel should access the interior of the equipment. The power supplies produce high voltages and energy hazards, which can cause bodily harm.
- Use extreme caution when installing or removing components. Refer to the installation instructions in this document for precautions and procedures. If you have any questions, please contact ASIS Technical Support.
- Always follow the procedural instructions for component removal and replacement in sequence.

Power

High voltages are present inside the chassis when the unit's power is plugged into an electrical outlet. Turn off system power, turn off the power supply, and then disconnect the power cord from its source before removing the chassis cover.

Turning off the system power switch does not remove power to components.

Make sure the work environment is grounded, and use a grounding wrist strap when handling the product.

ESD Safety Practices

Many components described in this document can be damaged by *electrostatic discharge* (ESD). Follow the precautions described here and before specific procedures in the document to protect static-sensitive components from ESD-related damage.

Static electricity can harm system boards. Perform service at an ESD workstation and follow proper ESD procedure to reduce the risk of damage to components. ASIS strongly encourages you to follow proper ESD procedure, which can include wrist straps and smocks, when servicing equipment.

Take the following steps to prevent damage from electrostatic discharge (ESD):

- When unpacking a static-sensitive component from its shipping carton, do not remove the component's antistatic packing material until you are ready to install the component in the system. Just before unwrapping the antistatic packaging, be sure you are at an ESD workstation or grounded. This will discharge any static electricity that may have built up in your body.
- When transporting a sensitive component, first place it in an antistatic container or packaging.
- Handle all sensitive components at an ESD workstation. If possible, use antistatic floor pads and workbench pads.
- Handle components and boards with care. Don't touch the components or contacts on a board. Hold a board by its edges or by its metal mounting bracket.
- Do not handle or store system boards near strong electrostatic, electromagnetic, magnetic, or radioactive fields.

Revision History

Number	Date	Comments	Author
1.0.0	Sep 2007	Initial release	Yossi Kuzi

About this Document

This document provides technical information for the Effective 2-Slot ATCA Shelf .

It is intended for technical staff tasked with installing, setting up and configuring the system, and providing troubleshooting assistance and servicing.

Related Documents

For information on the Shelf Manager, see the ASIS Shelf Manager Carrier Board user manual.

Instructions relating to software installation and documentation for application software development for this platform are available in the Shelf Manager External Interface Reference Manual.

For Asis product information and additional resources, please visit the Asis website at <http://www.asis-pro.com>.

Downloads (manuals, release notes, software, etc.) are available via the Technical Support Library at <http://www.asis-pro.com>.



Information about PICMG (PCI Industrial Computer Manufacturers Group) and the ATCA standard may be accessed on the PICMG Web site at <http://www.picmg.com>.

■

Chapters and Their Contents

1	Introduction	General overview of the product family and the shelf.	Pg. 13
2	Understanding the Shelf Components	Describes the shelf and its components, including the boards installed in the shelf: Backplane, Power Entry Module, Shelf ID Boards. Describes the cooling capabilities of the shelf.	Pg. 13
3	Installing the Shelf	Procedures and precautions involved in product installation	Pg. 28
4	Maintenance And Troubleshooting	Periodic maintenance, troubleshooting and diagnostic procedures, as well as module replacement instructions	Pg. 32
5	System Specifications	Detailed quantitative information about the system's dimensions and operational parameters, operation limitations, certification and standard compliance	Pg. 41

Style Conventions

Verdana	Regular text.
Arial Bold	Commands, keys and other parts of the user interface.
<i>Arial Italics</i>	Names of classes, methods, arguments, exceptions, properties, etc. Also used for special terms, the first time they appear.
Monospace	Text displayed on the LCD or on a computer attached to the product.
	Notes , which offer an additional explanation or a hint on how to overcome a common problem.
	Warnings , which indicate potential safety hazards regarding product operation or maintenance to operator or service personnel.

1 Introduction

This chapter includes a summary of the Asis Pro shelf product line and a brief overview of the Effective 2-Slot ATCA Shelf. For acronyms used in this document see Section 5.3.

1.1 Overview of ASIS Shelf Products

ASIS offers two product families:

- **Effective** - for cost-sensitive, yet demanding applications and
- **Perform** - for top-of-the line solutions, for environments in which high levels of performance, availability and reliability are mandatory.

1.2 ATCA AC Shelf

The Effective 2-Slot ATCA Shelf offers the reliability and availability of the Telco-grade standards in a cost-effective package, where maximum possible performance (backplane interconnect bandwidth, power levels and thermal capabilities) is provided in a low-cost shelf.

It incorporates the latest technologies available to reduce its price while maintaining performance and reliability. The system offers optional redundancy for power input and management functions. All shelf assemblies are designed using Field-Replaceable Units (FRUs), thus enabling easy and fast field maintenance with minimum or no downtime.

In addition, an ASIS cable-holder frame can be fitted to both side-mounting flanges of the shelf.

The Effective 2-Slot ATCA Shelf complies with FCC, and CE certification, and it is designed to comply with UL, NEBS Level-3 and ETSI.

It is fully complies to AdvancedTCA, PICMG 3.0 R2.0, and IPMI v 1.5.

See Section 5.2 for detailed system specifications.

2 Understanding the Shelf Components

This chapter summarizes the functional features of the Effective 2-Slot ATCA Shelf, and describes in further detail each of the components as well as the shelf system cooling mechanism.

The system was designed to withstand extreme conditions (to meet rigid Telco requirements). It is designed to incorporate Field-Replaceable Units (FRUs), and is fully field-serviceable.

2.1 Platform Components

A typical platform consists of the following key components:

- **19-inch rack mount shelf** — Base hardware element of the platform, which holds all the components together.
- **Card cage** — Portion of the shelf that holds the modules that are plugged into the backplane. Mechanically compliant with all aspects of PIMG 3.0.
- **Backplane** — Supports one or five third-party ATCA-compliant front boards, and the complementary rear transition module (RTM). The backplane provides full-mesh Fabric interface, and direct mating to the PSs and to the redundant Shelf Manager carrier board.
- **Power Supply (PS)** — Redundant, field replaceable, 120 VAC to 240 VAC, power supplies.
- **Fan tray** — Hot-swappable, provides side to side cooling, and is designed to provide N+1 fan redundancy cooling to components on the front and rear of the shelf.
- **Air filter tray** — Keeps the airflow free of dust and particles.
- **Blank Panels** — For air flow management.
- **Shelf ID Board**
- **Cable management** Holders for Front cable management
- **Rear connection boards**

2.1.1 Shelf and Boards

Figure 1 shows the block diagram of the shelf and *figures 2* and *3* show front and rear views of the shelf with key components highlighted.

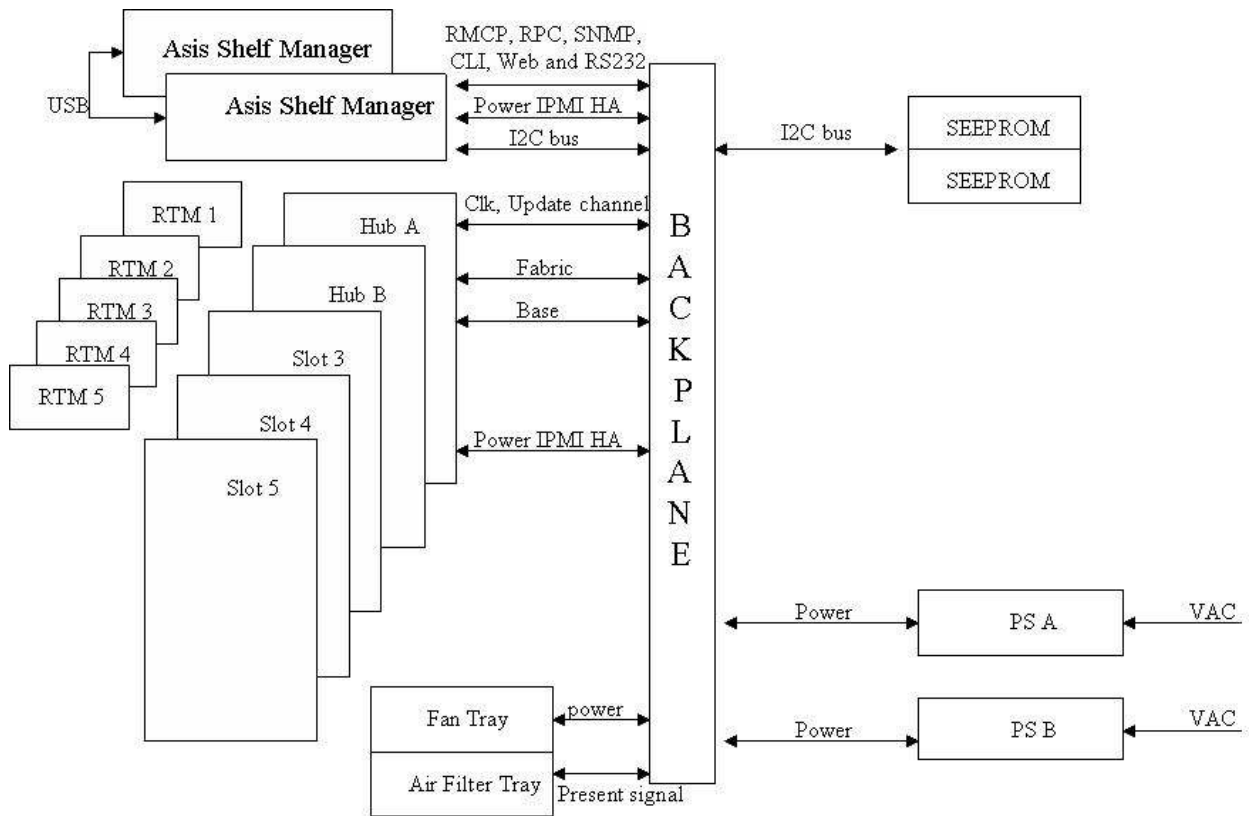

Figure 1 – Shelf Block Diagram

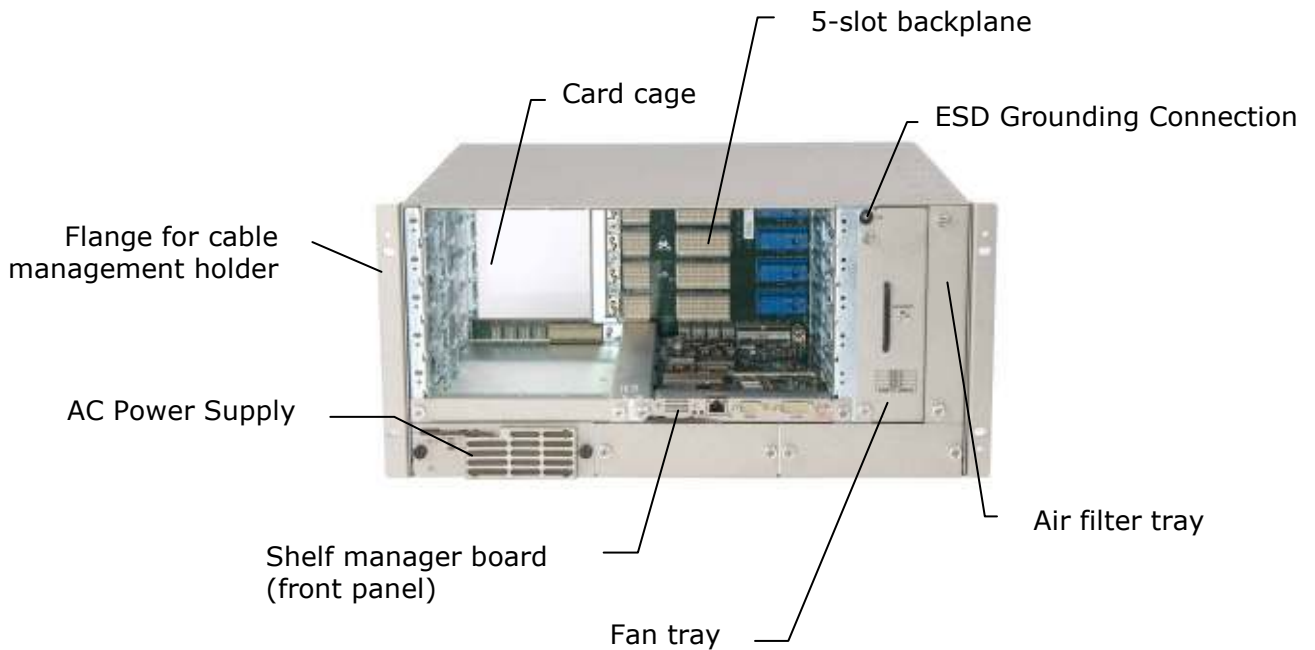

Figure 2 – Shelf Front View

Understanding the Shelf Components

Platform Components

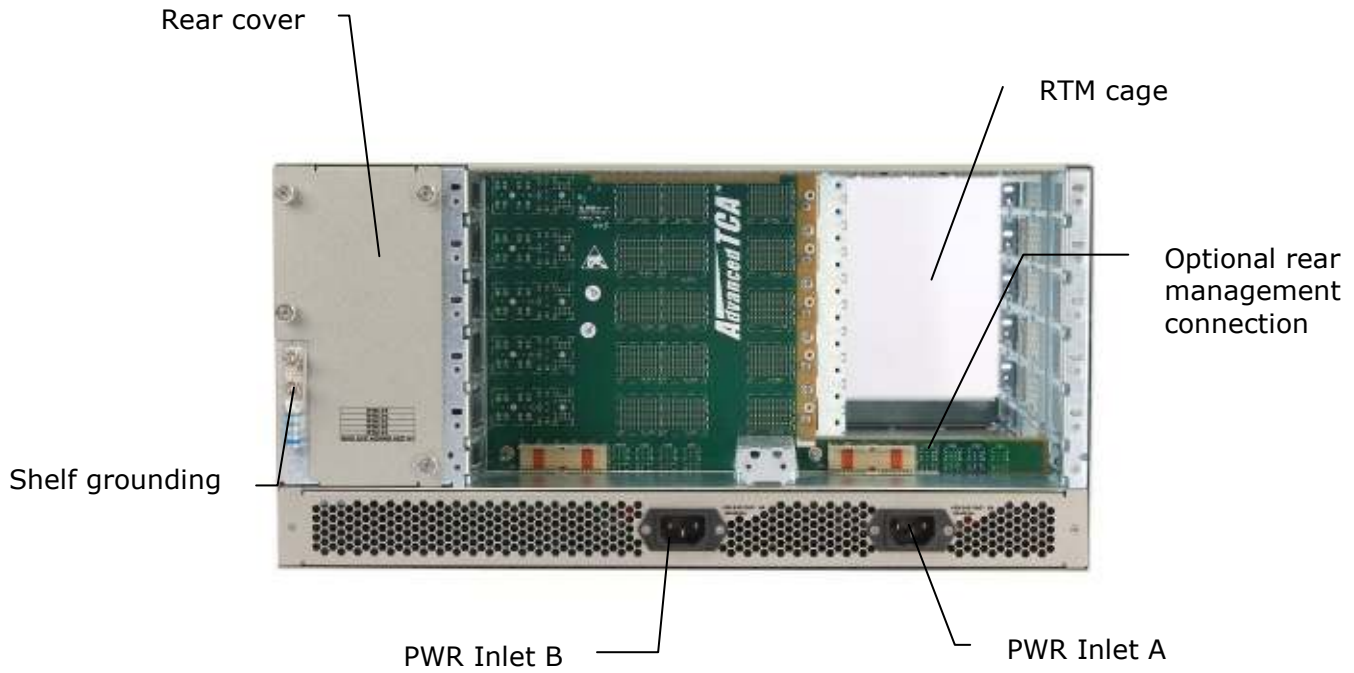

Figure 3 – Shelf Rear View

Figure 4 illustrates the use of cable holders:

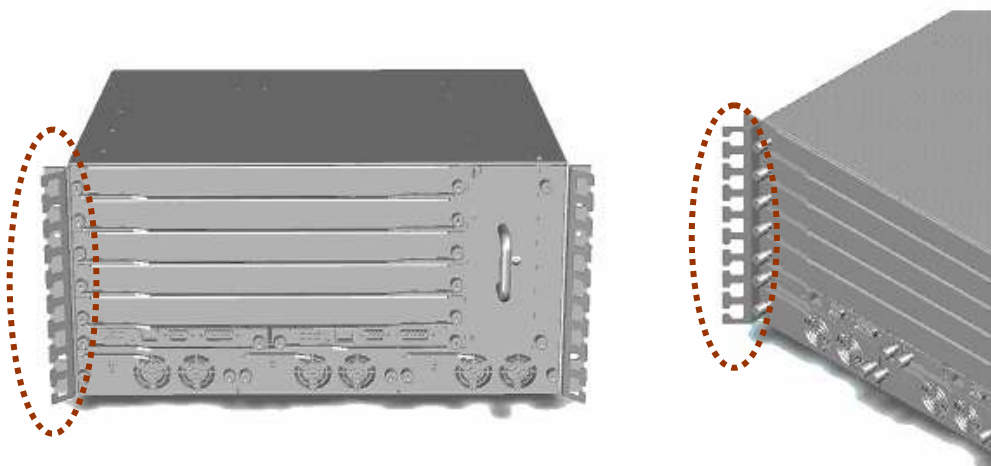

Figure 4 – Shelf Chassis with Cable Holders

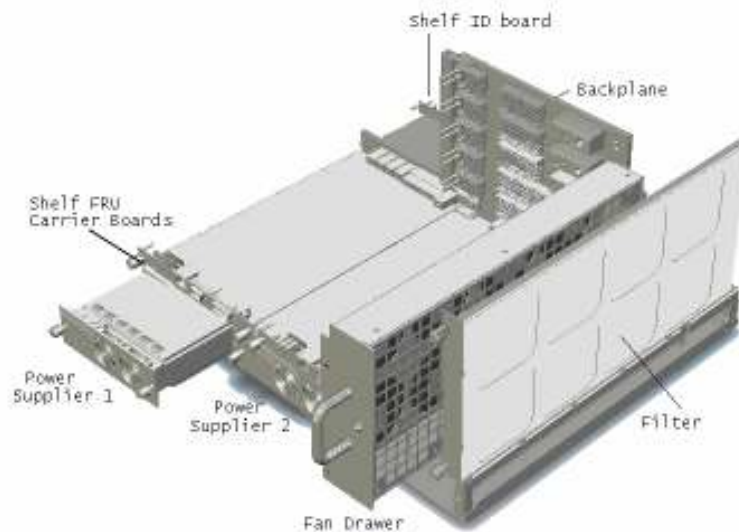

Figure 5 - Shelf Component Positioning

In order to increase ASIS 5 slot ATCA AC Shelf reliability, and to simplify the shelf's format, only one of the boards installed in the Shelf has logic circuits in it. All other boards and FRU's are passive.

Only the backplane is a fixed board. Remaining boards are removable:

Fixed Board

- Backplane

Removable Boards

- Shelf Manager board (see the ASIS Shelf Manager Board User Manual).
- Shelf ID: this board hosts two E²PROMs that contain data about the shelf
 - such as serial number and manufacturer – and about the board's setup
 - such as shelf thermal budget and slot population.
-

2.1.2 Card Cage

The shelf's card cage is composed of:

- the backplane
- right and left guide rails to hold the modules that plug into the backplane.

The card cage supports five 8U front boards, and five 8U RTMs.

The guide rails in the card cage incorporate *electrostatic discharge (ESD)* clips.

2.1.3 Backplane

Features

The ATCA PICMG 3.0-compliant backplane provides external interfaces and card connectivity. It conforms to the *PICMG 3.0 R2.0 AdvancedTCA Base Specification*. Backplane features include:

- Five slots
- Fabric interface with full mesh interconnect.
- The Fabric Interface grid consists of eight differential pairs per channel; The Base Interface grid consists of four differential pairs per channel.
- Dual-star Ethernet signalling environment on the Base interface
- Bussed IPMI (radial IPMI available upon request)
- Two hub slots
- Hub slots are slots 1&2
- update channel between slots 1&2 and 3&4
- 10, 100 and 1000 BASE-T dual star Base Interconnect capability. Update-channel interfaces for active and standby synchronization, and mesh topology handling up to 5Gbps per differential pair.
- Connection capacity for up to five third-party ATCA-compliant front boards, as well as to the redundant Shelf Manager Carrier board and redundant Power Supply units.
- Full compliance with AdvancedTCA™ electrical and mechanical specifications (Basic backplane topology is "full mesh".)
- Interconnect for system power for five slots.
- Base Interface Channel 1 (ShMC) of Logical Slot 1 is routed to the left dedicated Shelf Manager slot on the ATCA Backplane. Base Interface Channel 1 (ShMC) of Logical Slot 2 is routed to the right dedicated Shelf Manager slot on the ATCA Backplane.

There are no active components on the backplane, and no removable or serviceable parts on the backplane board.

The backplane has two functionally-distinct parts: right and center left:

- Right backplane (consists of Zone 1 connectors) – dual-power connections, which means the power connections from the PS's are independently supplied to each module plugged into the backplane. The modules also include fuses that protect the backplane power connections from an electrical short on a module.
- Center left backplane (consists of Zone 2 connectors) – connectivity for the Base, Fabric, and update-channel interface. This portion supports a full-mesh topology for both the Base and the Fabric interfaces.

Update-Channel Connections

The update channels are backplane connections between pairs of modules that operate on a redundant basis. Application software can use the update channel for redundancy interlock, or to provide a direct connection that bypasses the (indirect) fabric interface.

If you configure a pair of modules to use the update channel for redundancy support, you must insert the two modules into slots linked by an update channel.

Figure 6 shows the update channel connections.

Each update channel consists of 10 differential-pair connections. If an update channel connects two modules that are not identical, the Shelf Manager disables the update channel between them.

Synchronization Clock Interface

The backplane supports a set of synchronization clock buses that can exchange synchronization timing information. This synchronization can be used for system-wide and intersystem synchronization purposes, which are important in some applications, such as those involving synchronous time division multiplex (TDM).

Row #	Interface	Px20 Connector Pairs							
		ab		cd		ef		gh	
1	Clks	CLK1A+	CLK1A-	CLK1B+	CLK1B-	CLK2A+	CLK2A-	CLK2B+	CLK2B-
2	Update channel & Clks	Tx4(UP)+	Tx4(UP)-	Rx4(UP)+	Rx4(UP)-	CLK3A+	CLK3A-	CLK3B+	CLK3B-
3		Tx2(UP)+	Tx2(UP)-	Rx2(UP)+	Rx2(UP)-	Tx3(UP)+	Tx3(UP)-	Rx3(UP)+	Rx3(UP)-
4		Tx0(UP)+	Tx0(UP)-	Rx0(UP)+	Rx0(UP)-	Tx1(UP)+	Tx1(UP)-	Rx1(UP)+	Rx1(UP)-
The update channels are routed to adjacent slots. Slot 1 connects to Slot 2, and Slot 3 connects to Slot 4.									

Figure 6 – Synchronization clock and update channel pin assignments

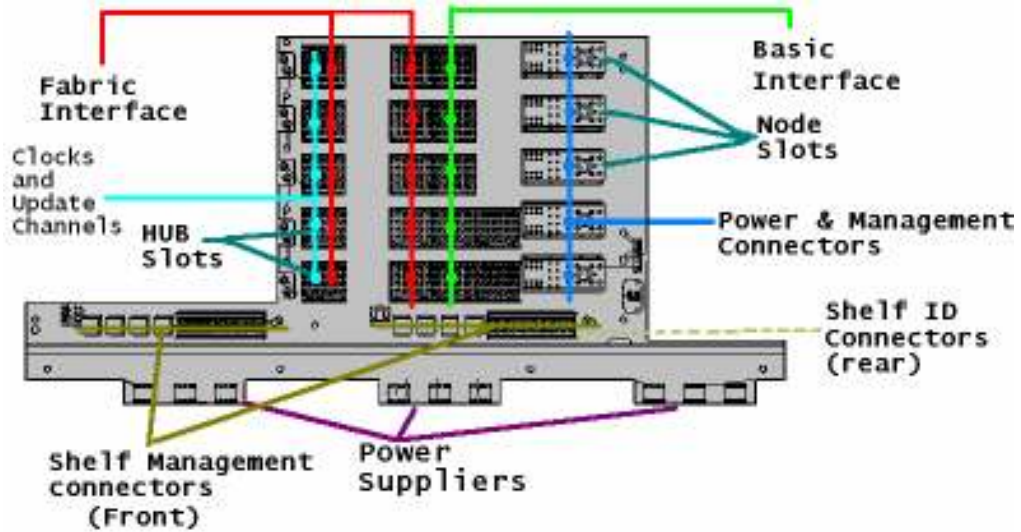

Figure 7 - Backplane Layout

2.1.4 Module Slot Identification

The shelf is compliant with PICMG 3.0 R2.0, and accepts modules compliant with this standard.

Figure 8 illustrates the locations of the module slot allocations when viewed from the front. The physical and the logical slot allocations are the same for this shelf: the slots are numbered 1 to 2 from bottom to top.

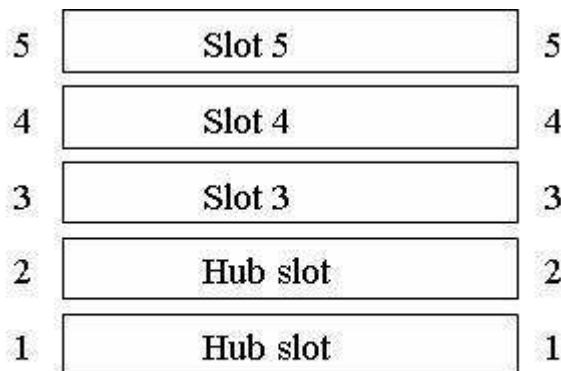

Figure 8 – Slot Allocations

The following table shows the hardware addresses in relation to the slot numbers and slot addresses. Slots are shown in the same order as they appear in the shelf: slot 2 above slot 1.

Slot Number	Hardware Address (8 bit format)	Hardware Address (7 bit format)
5	8Ah	45h
4	88h	44h
3	86h	43h
2	84h	42h
1	82h	41h

Figure 9 - Shelf Addressing

2.1.5 AC Power Supply

The field replaceable, 120 VAC to 240 VAC, power supplies provide power to the shelf.

The ASIS 5 slot ATCA AC Shelf is equipped with AC connectors for two redundant – hot swappable and field replaceable power supplies.

Both power supplies are located in the lower part of the shelf, on a drawer that slides up to the middle of the chassis, fitting directly into to the backplane and the AC connectors. Each PS has its own front-back independent cooling. In order to comply with NEBS GR63 Core the power supply drawers have separate removable air filters.

The AC connectors are located on the rear of the chassis.



Figure 10 – ATCA 1200W AC Power Supply

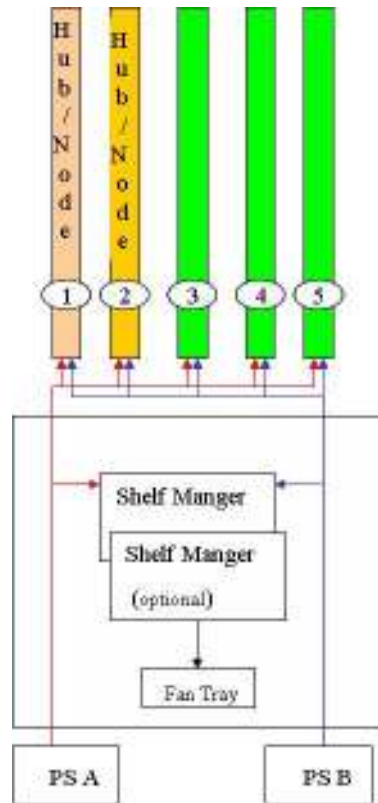

Figure 11 – PS Distribution of Power on Shelf

Grounding Requirements and Power Input



When connecting ground and power cables to the shelf, follow instructions in the beginning of this document.

2.1.6 Fan Tray

The fan tray is a closed module containing eight 80x80mm fans that supply air volume and velocity for cooling the high-density/high-performance computing environment (see Figure 12). The cooling power of the four fans can dissipate the heat generated by up to five front boards and complementary RTMs.

More than 200W for front board and 15W for RTM, per slot is supported.

Six of the fans are dedicated to cooling the front side of the shelf, while two are shared between the front side boards and the rear side I/O equipment.

The fan tray is designed with N + 1 redundancy to meet the cooling requirements of a full shelf.

In case of single fan failure, the remaining fans provide the required cooling to dissipate the heat generated by the occupied slots.

It is recommended to replace the fan tray as soon as possible.

The fan tray is factory-mounted in the Effective 2-Slot ATCA Shelf. It is easily replaceable, and can be replaced while the shelf is operating.

For more on shelf cooling, see Section 2.2.



Figure 12 – Fan Tray

2.1.7 Air Filter Tray

A NEBS-GR63-compatible air filter comes installed on the ASIS Effective 5 slot ATCA AC Shelf. The filter is field-serviceable, and can be extracted for periodic field maintenance or for field replacement.

The filter is easily accessible from front right side of the card cage. A shelf-based micro-switch detects the installed filter and reports its presence to the Shelf Manager.

For instructions on air-filter maintenance, see Section 4.1.2.



Figure 13 – Air filter tray

2.1.8 Blank Panels with/without air baffles

Compliance with ATCA's temperature specifications requires a steady air flow in the shelf. To insure a steady air flow, either the ASIS Effective 5 slot ATCA AC Shelf must be fully populated, or a blank panel, available from ASIS, must be equipped to fill every empty slot.

The "blank panel" is designed to emulate the air flow restriction in a standard card, thus ensuring the required conditions for proper cooling.

Three types of airflow-management panels are available for the empty slots on the shelf. These include panels specifically designed for:

- blank front module panels, with/without air baffle;
- blank RTM panels;
- an empty shelf-manager panel slot.



Figure 14 - Blank Board Panel and Blank RTM Panel

2.1.9 Shelf ID Board

A shelf ID board containing two redundant field replaceable E²PROM chips is housed in the rear of the Effective 5 slot ATCA DC Shelf.

The E²PROMs store product and manufacturer information such as shelf serial number, part number, backplane routing assignment, and shelf heat budget.

When the Shelf Manager board boots up, it compares the information stored in the two E²PROMs:

- If E²PROM data coincides, it is loaded and saved in the ShMC Board, and the shelf initializes.
- In case of a mismatch, the data on the E²PROMs is compared with the last saved configuration in the ShMC Board:

- If the saved configuration matches one of the E²PROMs it is assumed to be the right one and it is stored in both E²PROMs.
- If the three configurations are all different, the Shelf manager board will not boot up.

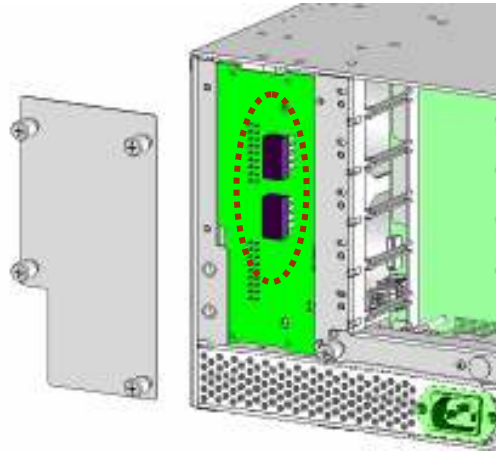

Figure 15 - Shelf ID Board with two E²PROMs (rear cover removed)

2.1.10 Holder for Cable Management (Optional)

A cable holder frame can be fitted to both side mounting flanges of the shelf.



Cables attached to the cable management holder must be allowed to move freely; Insure that a service loop of minimal required length is maintained.

2.2 Shelf Cooling

2.2.1 Overview

ASIS Effective 5 slot ATCA AC Shelf complies with all the cooling requirements specified in PICMG V3.x specifications.

The cooling system consists of eight high-performance fans. The air comes in from the right side and exits through the left side of the shelf. The fault-tolerant design is optimized for airflow of up to 200W per module.

2.2.2 Fan Tray Design

ASIS Effective 5 slot ATCA AC Shelf ventilation is achieved by eight 80mmx80mm fans, installed in the fan tray. The fans provide for n+1 redundancy.



Figure 16 - Fan Tray

The fan tray connects directly to the backplane, where it plugs into power and control connectors. The fan tray unit is front-serviceable, and can be easily replaced without tools.

In order to minimize possible failures, fan tray does not contain any active electronic components. The shelf management FRU fully controls adjustments of the fans based on temperature changes.

Cooling ability is maintained even in the case of a single fan failure. In this case, the green LED of the fan tray turns red, so that it is easier to identify the tray that needs to be replaced.

2.2.3 Performance

The eight fans supply air volume and velocity for cooling the high-density/high-performance computing environment. The cooling power of the fans can dissipate the heat generated by up to five front boards and complementary RTMs. At least 200W per front board and 15W for RTM per slot is supported.



Refrain from clogging air input and exhaust during chassis operation.

2.2.4 Fan Speed

When the shelf initialize, the fans start at full speed, only after the Shelf Manager finishes it's boot, it decide, according to the temperature algorithm to reduce the fans speed. Each time it reduces the fans speed by 7%.

When a fan tray is inserted into the shelf, (ex: replacement after a malfunction) all the fans start at full speed and then decrease by steps of 7% , Under normal operating conditions at room temperature, the fans run at 21% of full speed. The lower speed reduces the acoustic noise and increases the longevity of the fans. The Shelf Manager controls the fans thru a PWM (pulse-width modulation) method.

The speed of each individual fan is monitored by the Shelf Manager thru discrete channel. If the speed of any of the fans drops below the desired fan speed, the other fans will speed up to compensate. The Shelf Manager logs such events in its system event log (SEL) as a fault condition. If this occurs, replace the fan tray as soon as possible to restore fault tolerance and redundancy.

2.2.5 Rear connection boards

As an option, two rear connection boards can be installed in the rear part of the ASIS Effective 5 slot ATCA AC Shelf.

These connection boards allow the user to connect the Ethernet LAN and the management console, to the rear part of the shelf instead of the front. In case this connection is to be used, a series of "jumpers" have to be set on the Shelf FRU.

The shelf is equipped with two redundant – hot swappable and field replaceable rear connection boards, where one is active and the second one provides redundancy.

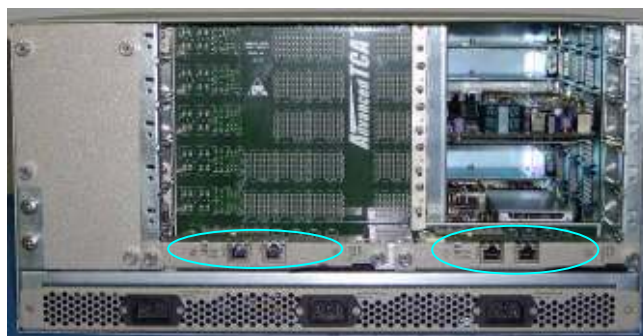

Figure 17 - Optional Rear Connection boards

3 Installing the Shelf

This chapter provides you with instructions on how to prepare the Effective 2-Slot ATCA Shelf for use.

You will be performing some or all of the following setup tasks:

- Site Planning
- Checking Package Contents
- Rack Mounting
- **Error! Reference source not found.**
- **Error! Reference source not found.**
- Shelf Application Card Insertion
- Redundant Module Installation.



Before installing the Effective 2-Slot ATCA Shelf, you should be aware of what cables will be needed for equipment and power, and whether they will be connected in the front or rear of the shelf.

3.1 Tools Required

To install the shelf in a standard 19" rack, the following tools are required:

- Standard Philips screwdriver set
- Wrench
- ESD grounding bracelet.

All the modules in the Effective 2-Slot ATCA Shelf are field-replaceable units (FRUs) requiring no special tools for mounting other than those mentioned above.

3.2 Site Planning



Only qualified personnel should be involved with this installation procedure.

The Effective 2-Slot ATCA Shelf can be installed either on a standard 19" rack or as a desk-top unit. All sides of the shelf should be easily accessible.

The prerequisites for setting up the Effective 2-Slot ATCA Shelf for use in your facility involves:

- If a rack is used, it should be properly grounded.

- A readily accessible disconnect device must be incorporated into the building's wiring between the shelf's PS input terminals and the power source.
- The disconnect device rating required is determined by the nominal input voltage.
- To ensure sufficient airflow for the individual blades in the shelf, allow at least two inches of clearance at the side air inlets and outlets.

3.3 Checking Package Contents

The following items are included in the Effective 2-Slot ATCA Shelf package. Check that all items in the package are intact.



Use of equipment damaged during delivery could prevent proper functioning of the Shelf and/or cause permanent damage to it. Check all pins, screws and other components before using any of the package contents.

- Shelf chassis with backplane
- Fan tray
- Air filter tray
- 1 1200W Power-Supply
- 2 Cable-management holders (optional).

3.4 Installation Steps

The following overall procedure is described more in detail in the sections below.

This operation should be maintained at least by two persons.

1. Mount the chassis in the rack with four screws.
2. Connect the chassis to the site ground with a ground cable.
3. Install the Cable-management tray holder (optional).
4. Insert a Shelf Manager Carrier board into the right Carrier slot.
5. Connect the power supply to a properly grounded mains socket.

3.5 Rack Mounting

You will need four M6x10 (or longer) screws to mount the chassis on the rack.

Before you begin:

- Verify that the transient operating temperature in the area of the rack does not exceed the 55°C maximum, and that the rack has support rails installed.

Installing the Shelf

Rack Mounting

- Confirm the rack is stable so that the weight of the shelf does not cause it to tip over.
- ➔ **To mount the shelf on the rack:**
- Insert the Effective 2-Slot ATCA Shelf chassis on the 19" rack, securing it by fastening the four mounting screws.
- The shelf should be level, and not positioned at an angle in the rack, and the rack's doors should be able to close.

3.5.1 Shelf Grounding

Connect rear grounding screws on the rear left side to insure that the shelf is properly grounded.

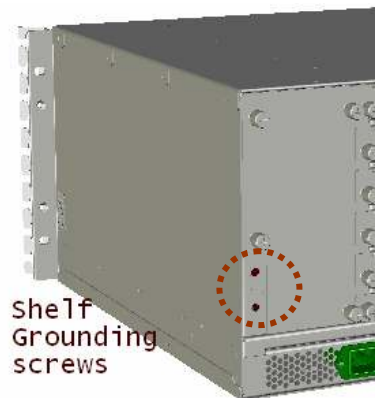

Figure 17 - Rear grounding screws

3.5.2 Installer Grounding



Any person involved in handling the shelf or card installation or replacement is required to wear an ESD grounding device.

One grounding sockets can be found on the shelf:

- an ESD grounding socket in the front of the shelf



Figure 18 - Front ESD Socket

3.6 Shelf Application Card Insertion

Third-party application cards must be ATCA-compliant.

Application cards should be inserted only after the installation, power-up and testing procedures of the Effective 2-Slot ATCA Shelf have been completed.

Insert application cards according to the manufacturer's instructions, making sure they are properly-positioned in their slots and are secured to their respective connectors.

When an application card is inserted and powered up, the blue LED should switch on and light steady for 10-30 seconds (depending on the card type). After that time, the blue LED should blink for about 10 seconds, and then go off.

Each third-party application card must provide a hot-swap LED. This LED can be in one of the following states:

Indicator State	Indication
Off	The card is not ready for removal or disconnection from the shelf
Blue	The card is ready for removal or disconnection from the shelf
Blinking slowly	The card is activating itself
Blinking quickly	Brief deactivation has been requested

3.7 Redundant Module Installation

3.7.1 Redundant Shelf Manager Card Installation

The redundant shelf manager Board is installed after the first shelf has finished Booting.

Follow the instructions for the first Shelf Management card in the Shelf Manager user manual.

4 Maintenance And Troubleshooting

This chapter includes instructions regarding:

- Performing Periodic Maintenance
- Figure 19 – Shelf Air filter and Power supply air filter extraction
- Handling Electromagnetic Interference
- Extracting Modules
- Handling Alarms
- Hot-Swapping FRUs
- Resetting The System
- Troubleshooting.

As required by the ATCA standard, the Effective 2-Slot ATCA Shelf applies a fully hot-swappable approach. Assuming redundancy has been provided for (i.e., two ShMC board units, and two PSs), all of the shelf assemblies can be field-replaced with no interruption to service, when redundant is applied .

Visual alarms provide clear indication of trouble, for easy problem location.

Malfunctions can be responded to quickly and easily, as no field repair is necessary. Failed modules can be easily extracted and replaced with no tools or with a minimal set of tools.

4.1 Performing Periodic Maintenance

This section provides procedural instructions on servicing or replacing shelf components.

Maintenance of the Effective 2-Slot ATCA Shelf involves the following tasks:

- Fan Tray Visual Inspection
- Air Filter Cleaning And Replacement.

For instructions on mounting the shelf in a rack, see Section 3.5 and the instructions provided by the rack's manufacturer.

4.1.1 Fan Tray Visual Inspection

The fan trays should be checked periodically for any visible damage that could prevent or disrupt normal fan operation.

See Section 4.3.5 for instructions on replacing a fan tray.

4.1.2 Air Filter Cleaning And Replacement

The air filter should be checked regularly. If environmental conditions are good, it may be enough to extract the filter and vacuum clean it. Otherwise it might be necessary to replace it.

The air filter can be ordered separately (i.e., without the metal tray).

Air filter cleaning must be performed in a different location from where the shelf is placed.

The air filter can be extracted without interrupting power. Release the two tumble screws on the front side of the air filter unit and extract the unit by pulling the two tumble screws.



Figure 19 – Shelf Air filter and Power supply air filter extraction

4.2 Handling Electromagnetic Interference

The shelf emits electromagnetic waves that may interfere with nearby equipment. Conversely, nearby electronic equipment may emit electromagnetic waves that interfere with the shelf. The EMC, EMI, and RFI specifications of the shelf and all nearby equipment should be considered when choosing the placement of the platform and surrounding equipment.

In the shelf and most other equipment, the use of **airflow management fillers** in otherwise unoccupied slots is necessary to keep the product's emissions within their specified limits.

- Install front and rear airflow management fillers into any empty slots.
- Do not use blank faceplates in place of fillers.
- Keep slots populated with active modules directly next to each other and fillers directly adjacent to the outermost active modules.
- If the shelf experiences unexpected and intermittent data errors, carefully consider the possibility of electromagnetic interference from nearby equipment as a possible source of the problem.

Identifying and measuring errors caused by electromagnetic interference can be challenging and may require the assistance of engineering personnel with experience in this field.

If your system configuration does not populate all front slots with active blades, you must fill those empty slots with additional blades or slot flow blocker blades to maintain system airflow and electromagnetic shielding integrity. Blank panels can be ordered separately.

4.3 Extracting Modules

4.3.1 FRU Module Extraction

➔ To extract an ATCA-compliant FRU module:

1. Pull the module's insertion lever slightly.
The de-activation sequence begins.
2. After the module's blue led lights steady, pull out the module's insertion lever.
3. Pull out the module.

4.3.2 FRU Module insertion

➔ To insert an ATCA-compliant FRU module:

1. Push the module's carefully inside the chassis .
2. The activation sequence begins
3. The blue (hot swap) led starts to light .
2. After the module's blue led turn off, the module is active.

4.3.3 Shelf manager insertion

➔ To insert a shelf manager:

1. Push the module's inward carefully.
2. push the insertion lever inward, making sure it goes fully in to the niche.
3. the blue led should start to blink until the shelf manager confirms that it's checksum it identical to the e²proms.
4. After the module's blue led turn off (data match), the module is active.

4.3.4 Shelf manager Extraction

➔ To extract a shelf manager:

1. Pull the module's insertion lever slightly.
The de-activation sequence begins.
2. After the module's blue led lights steady, pull out the module's insertion lever.
3. Pull out the module.

4.3.5 Power Supply Extraction

If Power Supply redundancy is implemented, one of the PS can be extracted without stopping service.

➔ To extract PS:

1. Disconnect the power cables.
2. Release the two tumble screws on the front side of the PS.

3. Fully pull out the PS' insertion lever.
4. Pull out the Power Supply.

4.3.6 Power Supply insertion

If Power Supply redundancy is implemented, one of the PS can be inserted without stopping service.

➔ **To insert a PS:**

1. Push in the PS
2. Fully push in the PS insertion lever.
3. Look if the Leds light.
4. tighten the two tumble screws back in to place

4.3.7 Fan Tray Replacement

The shelf should be used only with a fully-operational fan tray. A malfunctioning fan tray should be replaced immediately, in order to prevent thermal damage to the installed application cards.



Use care when handling the fan trays, and do not handle them from the connectors. Improper handling of the fan trays could cause damage to the connector pins.

Do not handle a fan tray while the fans are operating.

➔ **To replace the fan tray:**

1. Without interrupting power, release the two tumble screws on the front side of the fan tray.
2. Extract the tray by pulling at the handle, as shown below:



Figure 20 – Extracting a Fan Tray

3. Insert the replaceable fan tray unit.
4. Push each of the two thumbscrews in and tighten.

4.3.8 E²PROM Replacement

E²PROMs are generally installed and handled only in the factory. Follow the procedure below in the rare case that it becomes necessary to field replace the E²PROMs.

➔ **To replace an E²PROM:**

To replace an E²PROM:

1. Without shutting down the system, remove the rear panel, near the two chassis screws, by unscrewing the three tumble screws.
2. With the correct tool such as PLCC extractor or equal carefully remove the E²PROM (U1, U3 or both) from the board.
3. Insert the new E²PROM (U1, U3) into place. make sure it is inserted to the socket in the correct manner.
4. Refasten the rear panel using the three tumble screws.
5. From the management console, run the E²PROMS command manually (see the Shelf Manager External Interface Reference).

4.3.9 Third-Party-Module Replacement

As per ATCA specifications, all application modules must be hot-swappable.

For specific instructions regarding third-party module replacement, refer to the documentation provided by the manufacturer.

For general instructions on FRU module replacement, see Section 4.3.1.

4.4 Handling Alarms

Both visual indicators and software alarms are provided.

4.4.1 Visual Alarms

Nine LEDs at the front of the Shelf Management card provide visual alarms.

LED Functions: General LEDs

LED	Status	Meaning
ACT	Green	Shelf manager is active
	Red	Shelf manager failure
	Blink	Shelf manager is inactive
PWR	Green	Local voltage supply on Shelf manager is good
	Off	Local voltage failure
HS (hot swap)	Steady Blue	Shelf manager is powering up or ready for extraction
	Blinking blue	Shelf manager hot swap process
	Off	Shelf manager is operating

LED Functions: Telco Alarm LEDs

LED	Status	Meaning
CRT (Critical)	Off	Normal operation
	Red	System alarm event
MJR (Major)	Off	Normal operation
	Red	System alarm event
MNR (Minor)	Off	Normal operation
	Red	System alarm event

Upon completion of boot-up, LEDs will display as follows:

General LEDs		Telco Alarm LEDs	Application Defined LEDs
ACT	return to normal state	OFF	OFF
PWR	Remains ON		
HS	Lights steady blue for a few seconds, then begins blinking, then goes off after a few blinks		

4.4.2 Software Alarms

The ASIS Effective 2-Slot ATCA Shelf supports software alarms according to *PICMG Specifications 3.0*. Please refer to these specifications for a detailed description.

LED Functions: Application-Defined LEDs

LED	Status	Meaning
A	Green/ red/ bi-color	As defined by application
B	Green	As defined by application
C	Amber	As defined by application

4.5 Hot-Swapping FRUs

All the active components in the platform are mounted on (or housed in) field-replaceable units (FRUs) that you can easily remove and replace. The subrack, backplane, and other non-FRUs do not contain active components.

All FRUs are hot-swappable: you can remove and insert a FRU without shutting down any other shelf component. Hot swapping facilitates planned maintenance activities and FRU replacement.

The platform includes front-panel LEDs and a Telco alarm, which can be configured to activate when a hardware or software failure occurs. If an external alarm system is connected to the platform, it will also be activated for the alarm condition. The alarms alert an operator or technician to replace a failed FRU or perform some other maintenance operation.

The following procedures are to be used when modules are hot-swapped.

➔ **To remove a module:**

1. Partially open the module’s right ejector latch to activate the module’s hot-swap switch.

The module's IPMC sends to the Shelf Manager a request to deactivate, and the blue hotswap LED blinks at a fast rate.

2. The Shelf Manager determines whether the module can be extracted. If it can, the Shelf Manager grants permission to the IPMC.
3. The IPMC disables the interfaces that are controlled by electronic keying, and shuts down the module's operations. It then notifies the Shelf Manager the deactivation is complete. The blue LED remains lit.
4. Extract the module.
5. The Shelf Manager reclaims the module's power budget. Also, as part of electronic keying, the Shelf Manager disables—on other modules—the interfaces that are only shared with the deactivated module.

4.6 Resetting The System

One or both of the following reset options should be used if the shelf management card is not responding. (The second step should be performed only if the first one has not solved the problem.)

1. Press the Reset button on the ShMC (Shelf Manager card) board front panel.
2. Extract the ShMC board from the chassis, and re-insert it.

4.7 Troubleshooting

The following table summarizes potential problems and recommended solutions.

Problem	Probable cause	Solution
<p>ShMC ShMC board does not boot up properly:</p> <p>One or more of the LEDs fails to light during boot-up.</p> <p>The LEDs fail to return to their status as described in Section 4.4.1, above.</p> <p>The blue LED does not blink.</p>	<p>ShMC ShMC board is not in fully inserted in the cage.</p> <p>ShMC board failure.</p>	<p>Check that the ShMC ShMC board is properly inserted in the cage; Verify that the ejector clip is closed.</p> <p>Replace ShMC board.</p>
<p>Fans fail to operate at power up</p>	<p>ShMC board improperly inserted in the chassis.</p> <p>ShMC board failure.</p> <p>Fan tray failure.</p>	<p>Replace ShMC board.</p> <p>Replace fan tray.</p>
<p>Fan speed does not decrease after boot-up is completed</p>	<p>ShMC board failure.</p>	<p>Replace board.</p>
<p>Fan tray LED is lit red</p>	<p>One or more of the fans are not working.</p> <p>Logic failure.</p>	<p>Pull the fan tray out for few seconds until all fans stop spinning, and re-insert it.</p> <p>Replace fan tray.</p> <p>Replace ShMC board following this sequence:</p> <p>Insert a second ShMC board in the redundant slot;</p> <p>Issue a switchover command to switch shelf control from the current ShMC board to the redundant one;</p> <p>Extract the old ShMC board.</p>
<p>Circuit Breaker trips off</p>	<p>Chassis power trouble.</p>	<p>Replace Power Entry Module.</p> <p>Remove all third-party and ShMC boards to isolate the failure.</p>
<p>Boot sequence does not complete, and the blue LED continues to blink after the Shelf Management card has been replaced and all relevant monitor commands have been performed</p>	<p>One of the Backplane's connectors is damaged.</p> <p>One of the cage units, or the ATCA board, does not fit properly in the cage.</p>	<p>Replace E²PROMs. if you have not yet done so;</p> <p>Replace chassis.</p>

5 System Specifications

This chapter documents the product's standards certification, and physical and other technical specification parameters.

5.1 Certification

The Effective 2-Slot ATCA Shelf is targeted for NEBS level-3, FCC, UL and CE certification. It complies with the following standards:

- Advanced TCA, PICMG 3.x
- IPMI v 1.5.

5.2 Technical Data

The following table presents technical specifications for each of the product elements.

Category	Property	Description/ Value
Physical		
	Number of slots	5 slot 8Ux280mm, front blades; 5 slot 80mm, RTMs
	Dimensions	221.5mm (5U)"H x 448mm (17.637)"W (19" rack mount) x413.4mm (16.275)"Depth not including handles & cable holders
	EMI	EMI gasketing and hardware spacing to support FCC part B
	Weight	18Kg
	Compliance	PICMG 3.0 R.2.0
	Temperature	Humidity: 5% to 95%, non-condensed
		Storage Temperature: -40° to +70° Celsius
		Operating Temperature: -5° to +55° Celsius
	Other	Front and rear ESD jack
		Front rack flanges
		Front cable management tray

System Specifications

Technical Data

Category	Property	Description/ Value
Accessibility		
	Front	Shelf Manager, Fan Tray, Front boards, Air Filter Tray
	Rear	PSs, RTMs
Backplane		
	Bus architecture	Up to five third-party ATCA-compliant front boards, full mesh, dual redundant Shelf Management carrier boards, bussed IPMB (radial by request).
	Signal bandwidth rating	Supports up to 5Gbps per differential pair.
	Base interface	Base channel interconnect between two ATCA slots, with support for 10/100/1000 BASE-T Ethernet; base channel 1 is allocated to ShMC (Shelf Management Controller)
	Fabric interface	Fabric channel interconnect between two ATCA slots; Replicated fabric channel upon request.
	Hub slots	2 logical slots 1 & 2;
	Update channels	Update channel between slots 1&2 and 3&4
Power		
	AC Power Supply	Front redundant, self cooled, hot swappable, integral power supply.

Category	Property	Description/ Value
Cooling		
	Number of fans	Front hot-pluggable fan tray with 8, N+1, axial fans for front and RTM slots
	Redundancy	N+1 (i.e., any one fan can fail with no service degradation)
	Fan speed	Variable speed under shelf management control
	Cooling capacity	More than 200 Watt per front board, 20W per RTM slot - temp. rise: <9[C]
Alarm I/O		
	Electrical/Mechanical Placement	Dual redundant Alarm I/O Modules accessible from front of chassis
	Alarm I/O interfaces	15-pin DA-15P connector. Supports 4 outputs (Major, Minor, Critical, Power) and 2 inputs (Major & Minor Reset)
Regulatory		
	Safety	Designed to meet CE, UL, TUV requirements
	EMC	Designed to meet CE & FCC part 15 requirements
	Environment	Designed to be Compatible with NEBS level-3 and ETSI
Other		
	Shelf identity	Configuration board with on-board EEPROM stores shelf serial number, part number, backplane routing assignments, shelf heat budget and other data.
	Removable top cover	Available

5.3 Acronyms Used in this Manual

Acronym	Meaning
ATCA	Advanced Telecom Computing Architecture
FRU	Field-Replaceable Unit
HS	Hot swap
PS	Power Entry Module
IPMB	Intelligent Platform-Management Bus
IPMI	Intelligent Platform-Management Interface
RTM	Rear Transmission Module
NEBS	Network Equipment-Building Systems
ShMC	Shelf Manager Controller
ETSI	European Telecommunications Standards Institute
ANSI	American National Standards Institute
CE	"Conformité Européene" ("European Conformity")
PS	Power Supply
FCC	Federal Communications Commission
UL	Underwriters Laboratories - safety standards
CFM	Cubic Feet per Minute – Airflow measurement unit