

GETTING STARTED



In This Chapter...

Introduction	1-2
Conventions Used	1-3
Product Overview	1-4
Agency Approvals	1-5
Part Number Key	1-5
Product Label Examples:	1-6
Serial Number and Date Code formats:	1-6
Quick Start Steps	1-7
Step 1 – Unpack and Inspect	1-7
Step 2 – Install Optional Hardware Accessories	1-8
Step 3 – Become Familiar with Available Communication Ports	1-9
Step 4 – Install C-more Micro-Graphic Panel	1-10
Step 5 – Install the Programming Software and Develop a Project	1-11
Step 6 – Connect C-more Micro-Graphic Panel to Computer	1-12
Step 7 – Provide Power to the C-more Micro-Graphic Panel	1-13
Step 8 – Accessing the C-more Micro-Graphic Panel Setup Screens	1-14
Step 9 – Choose C-more Micro-Graphic Panel to PLC Protocol & Cables	1-15
Step 10 – Connect C-more Micro-Graphic Panel to PLC	1-16

Introduction

1

The Purpose of this Manual

Thank you for purchasing our *C-more*® Micro-Graphic family of products. This manual describes *AutomationDirect.com's C-more* Micro-Graphic panels, their specifications, included components, available accessories and provides you with important information for installation, connectivity and setup. The manual shows you how to install, wire and use the products. It also helps you understand how to interface the panels to other devices in a control system.

This user manual contains important information for personnel who will install the panels and accessories, and for the personnel who will be programming the panel. If you understand control systems making use of operating interfaces such as the *C-more* Micro-Graphic panels, our user manuals will provide all the information you need to get, and keep, your system up and running.

Supplemental Manuals

If you are familiar with industrial control type devices, you may be able to get up and running with just the aid of the Quick Start Guide that is included with each panel and accessory. You may also have need to refer to the On-line help that is available in the *C-more* Micro-Graphic programming software. The Quick Start Guide is included with each accessory that will help with installing the accessory.

Technical Support

We strive to make our manuals the best in the industry. We rely on your feedback to let us know if we are reaching our goal. If you cannot find the solution to your particular application, or, if for any reason you need technical assistance, please call us at:

770-844-4200

Our technical support group will work with you to answer your questions. They are available Monday through Friday from 9:00 A.M. to 6:00 P.M. Eastern Time. We also encourage you to visit our web site where you can find technical and non-technical information about our products and our company.

<http://www.automationdirect.com>

If you have a comment, question or suggestion about any of our products, services, or manuals, please fill out and return the 'Suggestions' card that was included with this manual.

Conventions Used



When you see the “notepad” icon in the left-hand margin, the paragraph to its immediate right will be a special note. The word **NOTE:** in boldface will mark the beginning of the text.



When you see the “exclamation mark” icon in the left-hand margin, the paragraph to its immediate right will be a warning. This information could prevent injury, loss of property, or even death (in extreme cases). The word **WARNING:** in boldface will mark the beginning of the text.

Key Topics for Each Chapter

The beginning of each chapter will list the key topics that can be found in that chapter.

Getting Started	
	
In This Chapter...	
General Information	1-2
Specifications	1-4

Product Overview

1

Touch
Screen



Non
Touch



EA1-S3ML, EA1-S3MLW*

EA1-S3ML-N, EA1-S3MLW-N*

C-more Micro-Graphic 3.1-inch Panels have an STN LCD, 128 x 64 dot monochrome display. Models EA1-S3ML and EA1-S3ML-N have 5 selectable backlight colors (green, red, amber, yellow and lime). Models EA1-S3MLW and EA1-S3MLW-N have 5 selectable backlight colors (white, pink1, pink2, pink3 and red). The panels have 5 user-defined functions keys with LED indicators. The panels can display up to 10 lines by 32 characters of static text and up to 10 lines by 21 characters of dynamic text with embedded variables and phrases mixed with graphics. Power is supplied to the panel through the serial communication port connection when used with AutomationDirect CLICK and most *Direct*LOGIC PLC's having a RJ12 communication port. Either EA-MG-SP1 (power supply with serial port option module) or EA-MG-P1 is required when connecting to third party PLC's. NEMA 4/4X, IP-65 rated (when mounted correctly). For **indoor** use only.

Other features include:

- 768 KB memory
- Built in RJ12 serial communications port
- Adjustable contrast
- 2 optional keypad bezels, 8-button or 20-button
- 2 optional DC Power Adapters, one includes 15-pin serial communications port (RS-232/422/485)
- Optional replaceable clear screen overlay
- Built in Alarm Control setup that activates beep, backlight flash, customized alarm banner, and red LED blinking
- Up to 999 screens, limited only by memory usage
- 0 to 50 °C (32 to 122 °F) operating temperature range
- UL, cUL, CSA & CE agency approvals (see following table for details)
- 2-year warranty from date of purchase



***Note:** *C-more* Micro-Graphic panels with the letter "W" in the part number designate units with five selectable background colors of White, Pink1, Pink2, Pink3 and Red. Part numbers without the letter "W" are provided with five selectable background colors of Green, Red, Amber, Yellow and Lime.



***Note:** Software and Firmware Version 1.5 or later is required with models EA1-S3MLW and EA1-S3MLW-N. Available for free download at www.automationdirect.com

Agency Approvals

UL/CUL/CE Certification Numbers					
Name	UL/CUL	UL508	CSA	CE	ISO-9000
<i>C-more</i> Micro-Graphic Panels & Accessories	E157382	E157382	234884	EN61131-2	Yes



Part Number Key

The *C-more* Micro-Graphic panel part numbers use the following key:

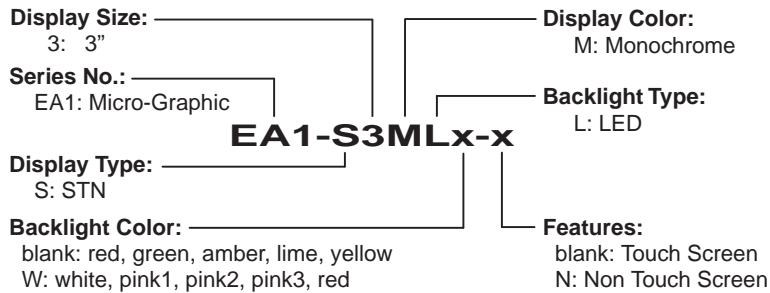

Product Label Examples:

EA1-S3ML
EA1-S3MLW

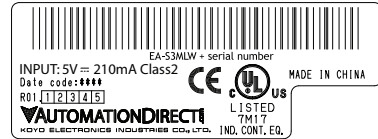

EA1-S3ML-N
EA1-S3MLW-N



Serial Number and Date Code formats:

Serial Number = [Part Number]+[YYMDDFNNN]

- YY:** Year (07–99 --- e.g. 07 = 2007)
- M:** Month (1–9, X, Y, Z --- e.g. X = Oct.)
- DD:** Day (1–31)
- F:** Manufacturing Site (0–9, A–Z)
- NNN:** Sequence number for the date listed (000–999)

Date Code = **YMMF**

- Y:** Year (0–9 --- e.g. 07 = 2007)
- MM:** Month (01–12 --- e.g. X = Oct.)
- F:** Manufacturing Site (0–9, A–Z)

Quick Start Steps

Step 1 – Unpack and Inspect

a.) Unpack the *C-more* Micro-Graphic panel from its shipping carton. Included in the carton are the following:

- *C-more* Micro-Graphic panel
- cutout template
- mounting clips (EA-MG-S3ML-BRK)
- gasket (EA-MG-S3ML-GSK)
- blank function key label insert (EA-MG-S3ML-FKL)
- Quick Start Guide (EA1-MG-QSG)

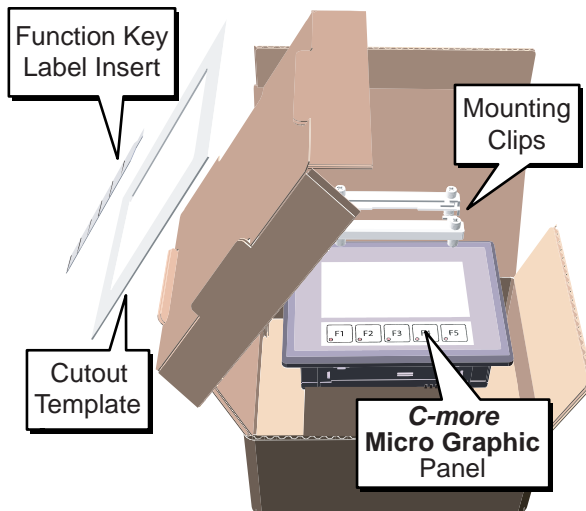

Shipping Carton Contents

- b.) Unpack any accessories that have been ordered, such as: Keypad Bezel, DC Power Adapter, programming cable, communications cable, etc.
- c.) Inspect all equipment for completeness. If anything is missing or damaged, immediately call the *AutomationDirect*® returns department @ 1-800-633-0405.

Optional Accessories

**8-Button Keypad Bezel
EA-MG-BZ1**



**20-Button Keypad Bezel
EA-MG-BZ2**



Step 2 – Install Optional Hardware Accessories

Below is an example of a *C-more* 3” Micro-Graphic panel being assembled with an optional EA-MG-BZ2 20-button Keypad Bezel. See the Quick Start Guide, EA1-MG-QSG, for additional assembly instructions and illustrations.

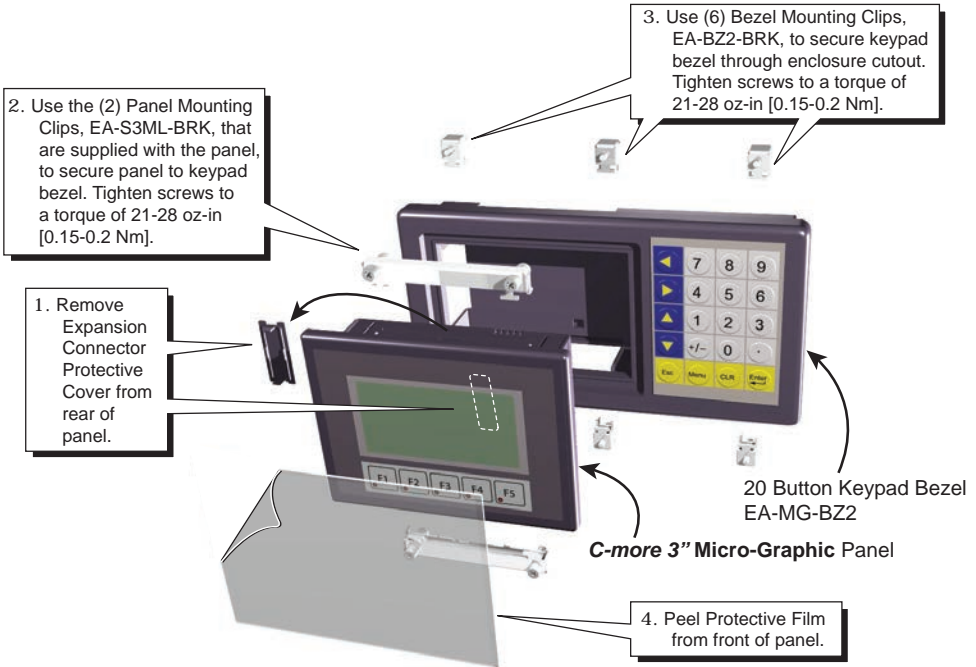

NOTE: Mounting clips for the panel and keypad bezels are included with the respective product.

Optional Accessories

DC Power Adapter
EA-MG-P1



Serial Port w/ DC Power Adapter
EA-MG-SP1



Clear Screen Overlay
EA-MG-COV-CL



Step 3 – Become Familiar with Available Communication Ports

The *C-more* Micro-Graphic panel includes a built-in RS-232 serial communications port designated as Port 1. This port uses an RJ12 type telephone jack to make connections to either the EA-MG-PGM-CBL programming cable assembly or a communications cable, such as an EA-2CBL, to interface with a PLC or controller. The panel can receive power through this port from the serial communications port on select AutomationDirect PLCs. The other serial communications port designated as Port 2 is available by installing the optional EA-MG-SP1 DC Power Adapter with Serial Port onto the rear of the panel, or if using an optional keypad bezel, install onto the rear of the bezel with the panel installed through the front of the bezel. Port 2 supports RS-232, RS-485 and RS-422.

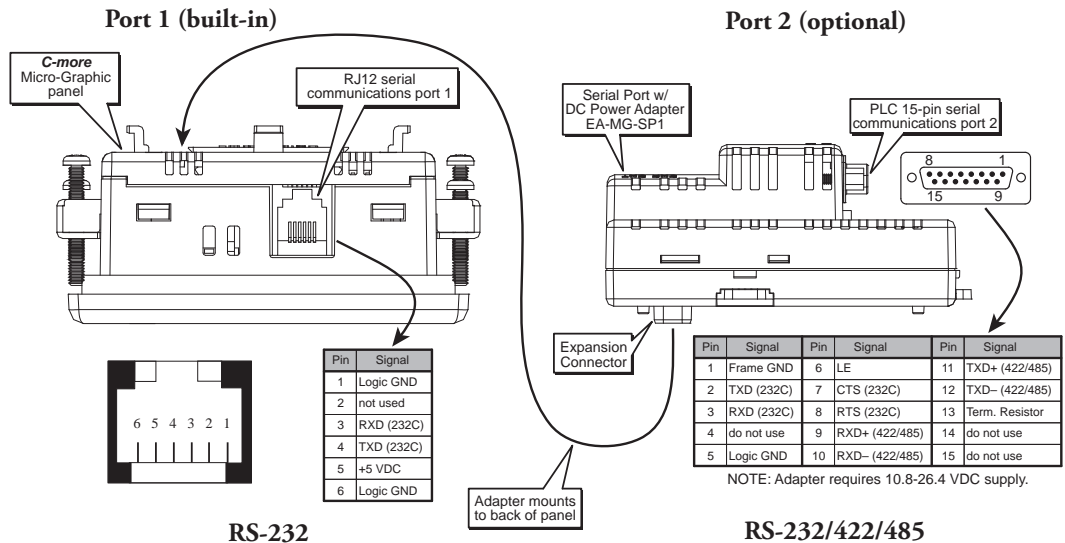

NOTE: See Chapter 2: Specifications and Chapter 6: PLC Communications for additional details on the available communication ports, protocols and cables.

NOTE: The panel has one built-in RJ12 serial communications port (Port1 - RS-232) and the option to add one 15-pin serial communications port (Port2 - RS-232/422/485) to the panel by installing the EA-MG-SP1 module. **Only one** of the ports can be used with a connected PLC. The programming software allows the user to select either Comm. Port1 or Comm. Port2 under the Panel Manager dialog box. When using Port 2 to communicate with the connected PLC, Port1 can still be used with the EA-MG-PGM-CBL Software Programming Cable Assembly to transfer projects between the PC and panel.

NOTE: If the DC power adapter is installed on the panel, the adapter must be powered.

Step 4 – Install *C-more* Micro-Graphic Panel

The *C-more* Micro-Graphic panel can be mounted through a cutout in an enclosure by using the template that is provided with the panel, or using the dimensions shown below. Cutout dimensions for the 8-button and 20-button keypad bezel options are also shown below. The enclosure mounting thickness range for the panels and the keypad bezels is 0.04”–0.2” [1–5 mm].

The screw torque range for the screws used on the panel mounting clips and the keypad bezel mounting clips is 21–28 oz-in [0.15–0.2 Nm].

See Chapter 2: Specifications for additional product dimensions.

Port 1 (built-in)

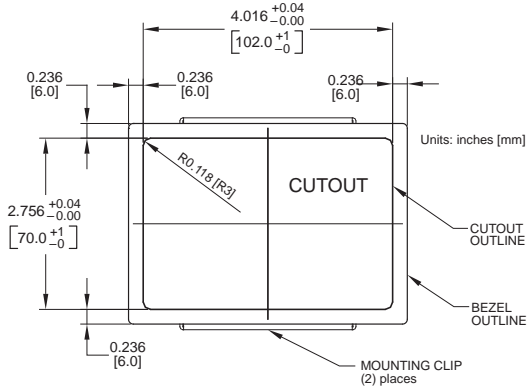

EA-MG-BZ1 Keypad Bezel Cutout

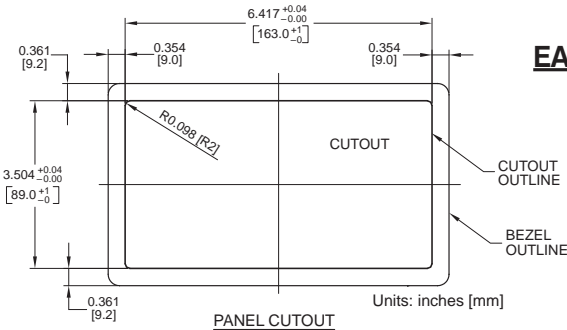

EA-MG-BZ2 Keypad Bezel Cutout

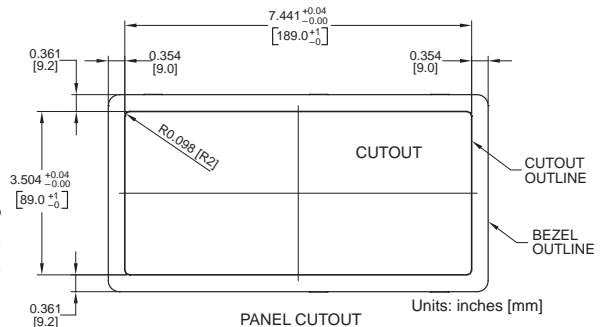

NOTE: A minimum clearance of 1.2 inches (30mm) must be maintained around and behind the panel to allow for proper cooling.

Step 5 – Install the Programming Software and Develop a Project

Following are the minimum system requirements for running *C-more* Micro-Graphic Programming Software, EA-MG-PGMSW, on a PC:

- Operating System - Windows® XP Home / Professional Edition Service Pack 2, Windows® 2000 with Service Pack 4, Windows® Vista (32 and 64 bit), Windows® 7 (32 and 64 bit), Windows 8 (32 and 64 bit)
- Keyboard and Mouse or compatible pointing device
- Super VGA color video adapter and monitor with at least 800 x 600 pixels resolution (1024 x 768 pixels recommended) 64K color minimum
- 150 MB free hard-disk space
- 128 MB free RAM (512 MB recommended); 512 MB free RAM (1GB recommended) for Vista
- CD-ROM or DVD drive for installing software from the CD, or internet access to download free programming software
- USB port to use with an EA-MG-PGM-CBL, USB to RS232 Programming Cable Assembly for project transfer from the programming software to the panel

Insert the supplied CD-ROM into the PC's CD-ROM drive and follow the instructions. If you need assistance during the software installation, please refer to the supplied Software Installation Guide or call the *AutomationDirect* Technical Support team @ 770-844-4200.

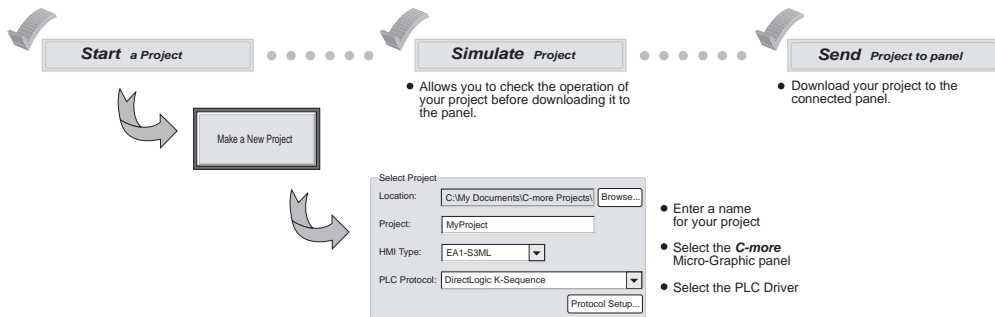

Step 6 – Connect *C-more* Micro-Graphic Panel to Computer

Use an EA-MG-PGM-CBL, USB to RS-232 Programming Cable Assembly, from an USB port type A on the project development PC, through the supplied converter, to the RJ12 RS-232 programming/PLC serial communications port on the *C-more* Micro-Graphic panel as shown below.

USB to RS-232 Programming Cable Assembly



Step 7 – Provide Power to the C-more Micro-Graphic Panel

- The *C-more* Micro-Graphic panel is powered during programming from the PC through the USB to RS-232 Programming Cable Assembly, EA-MG-PGM-CBL.
- During operation, the *C-more* Micro-Graphic panel can be powered from most AutomationDirect PLC's RJ12 serial communications port by using a DV-1000CBL communications cable, or a DV-1000CBL communications cable with a FA-15HD 15-pin HD DSub/RJ12 Adapter connected to a *Direct*LOGIC PLC's 15-pin HD communications port (DL06, D2-250-1 & D2-260) PLCs. See Chapter 6: PLC Communications for additional details.
- The panel can also be powered by installing either the EA-MG-P1 DC Power Adapter, or the EA-MG-SP1 Serial Port with DC Power Adapter to the back of the panel and supply the adapter from a 1 Amp @ 12-24 VDC class 2 power source.

Panel Powered from DirectLOGIC PLC via Communications Cable

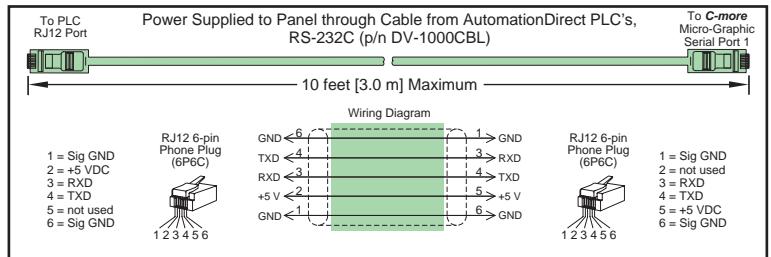

Panel Powered from a DC Power Adapter - Wiring Diagrams

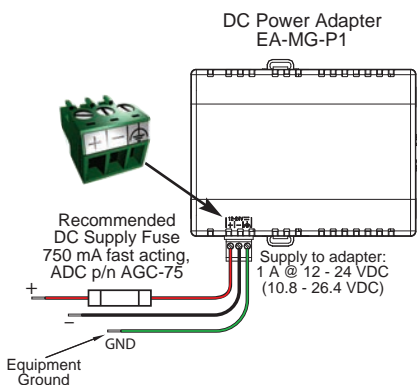

NOTE: If either DC power adapter is installed on the panel, the adapter must be powered.

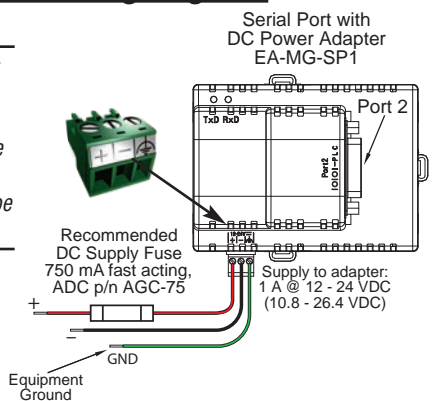

NOTE: Recommended DC power supply to power either DC Power Adapter, AutomationDirect Part No. PSC-24-015 or PSC-24-030.

Maximum communication cable length when powered from an optional DC Power Adapter

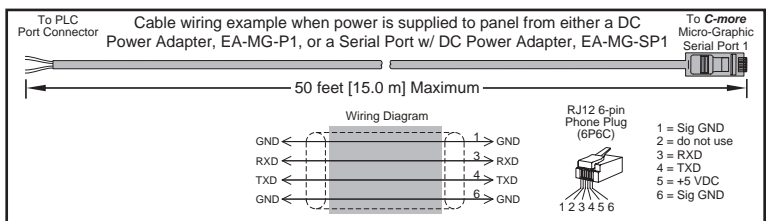

Step 8 – Accessing the C-more Micro-Graphic Panel Setup Screens

The panel needs to be in the Setup Menu mode whenever a project is uploaded or downloaded. To access the Setup Menu of the panel's setup screens, press the the F1 and F5 function keys simultaneously for three (3) seconds.



From the Setup Menu, information about the panel can be obtained, settings can be adjusted, and panel functions can be tested.



NOTE: See Chapter 5: System Setup Screens for details on using the setup screen settings and functions.

Examples

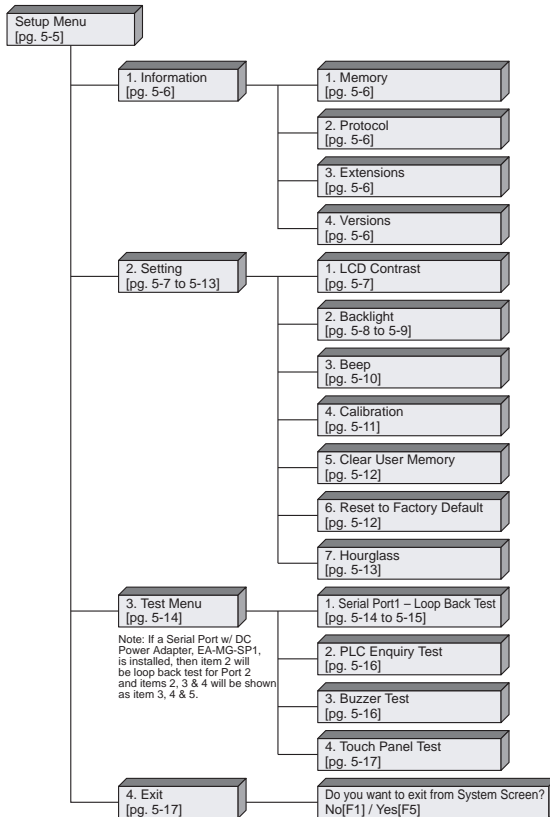
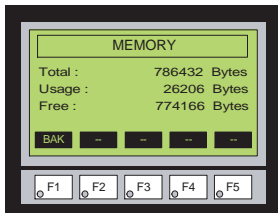
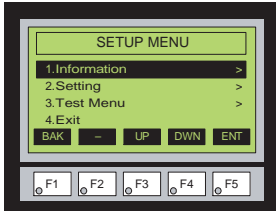

Step 9 – Choose *C-more* Micro-Graphic Panel to PLC Protocol & Cables**Available PLC
Protocols**

PLC Drivers	
<i>Serial - port1 or port2</i>	<i>Serial - port2 only</i>
AutomationDirect Productivity Series	Allen-Bradley DF1 Half Duplex
AutomationDirect Do-more	Allen-Bradley DF1 Full Duplex
AutomationDirect CLICK	Allen-Bradley PLC5 DF1
AutomationDirect K-sequence	Allen-Bradley DH485
AutomationDirect DirectNET	GE SNPX (90/30, 90/70, Micro 90, VersaMax Micro)
AutomationDirect Modbus	Mitsubishi FX
Modicon Modbus RTU	Mitsubishi Q & QnA
Entivity Modbus RTU	Omron Host Link (C200 Adapter, C500)
	Omron FINS Serial (CJ1, CS1)
	Siemens PPI (S7-200 CPU)
	AutomationDirect SOLO Temperature Controller
	AutomationDirect GS Drives

Available purchased cables

Cable Description	Cable Part No.
Cables used with serial Port1	
AutomationDirect Productivity Series, Do-more, CLICK, Direct LOGIC PLC RJ-12 port, DL05, DL06, DL105, DL205, D3-350, D4-450 & H2-WinPLC (RS-232C)	DV-1000CBL
Note: The PLC can provide 5 VDC through this cable. No external 12-24 VDC source is required, however, screen brightness is diminished and the alarm beep will not function.	
Direct LOGIC DL405 PLC 15-pin D-sub port, DL405 (RS-232C)	D4-1000CBL
Direct LOGIC (VGA Style) 15-pin port, DL06, D2-250 (250-1), D2-260 (RS-232C) Use with DV-1000CBL cable.	FA-15HD
Direct LOGIC PLC 15-pin D-sub port, DL405 (RS-232C).	FA-CABKIT
Direct LOGIC PLC RJ-11 port, D3-340 (RS-232C).	OP-3CBL-1

Cable Description	Cable Part No.
Cables used with serial Port2	
AutomationDirect Productivity Series, Do-more, CLICK, Direct LOGIC PLC RJ-12 port, DL05, DL06, DL105, DL205, D3-350, D4-450 & H2-WinPLC (RS-232C)	EA-2CBL
Direct LOGIC (VGA Style) 15-pin port, DL06, D2-250 (250-1), D2-260 (RS-232C).	EA-2CBL-1
Direct LOGIC PLC RJ-11 port, D3-340 (RS-232C).	EA-3CBL
Direct LOGIC DL405 PLC 15-pin D-sub port, DL405 (RS-232C).	EA-4CBL-1
Direct LOGIC PLC 25-pin D-sub port, DL405, D3-350, DL305 DCU and all DCM's (RS-232C).	EA-4CBL-2
Allen-Bradley MicroLogix 1000, 1100, 1200, 1400 & 1500 (RS-232C)	EA-MLOGIX-CBL
Allen-Bradley SLC 5-03/04/05, ControlLogix, CompactLogix, FlexLogix DF1 port (RS-232C)	EA-SLC-232-CBL
Allen-Bradley PLC-5 DF1 port (RS-232C)	EA-PLC5-232-CBL
Allen-Bradley MicroLogix, SLC 5-01/02/03, PLC5 DH485 port (RS-232C)	EA-DH485-CBL
GE 90/30, 90/70, Micro 90, Versamax Micro (Port2) 15-pin D-sub port (RS-422A)	EA-90-30-CBL
MITSUBISHI FX Series 25-pin port (RS-422A)	EA-MITSU-CBL
MITSUBISHI FX Series 8-pin mini-DIN (RS-422A)	EA-MITSU-CBL-1
OMRON Host Link (C200 Adapter, C500) (RS-232C)	EA-OMRON-CBL



NOTE: See Chapter 6: PLC Communications for a detailed chart of PLC compatibility & cable connections. Chapter 6 includes wiring diagrams for end user construction of certain cables.

Step 10 – Connect *C-more* Micro-Graphic Panel to PLC

Connect the serial communications cable between the *C-more* Micro-Graphic panel and the PLC. The panel can be connected to the PLC via the panel's built-in RJ12 serial communications port (RS-232) or by using the optional EA-MG-SP1 Serial Port with DC Power Adapter, the panel can be connected to the PLC from the adapter's 15-pin serial communications port with either RS-232, RS-422 or RS-485 communications.

Example of panel's Port 1 connected to a CLICK PLC

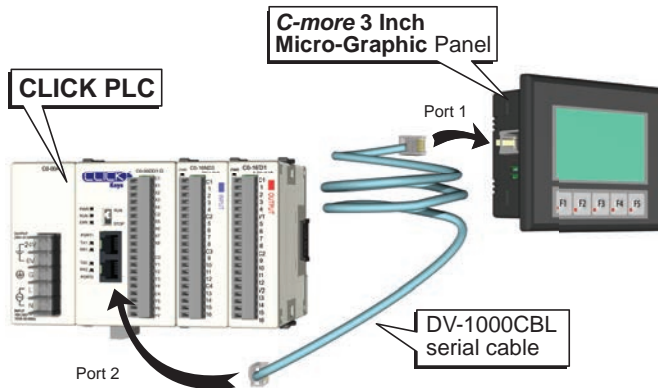

Example of panel's optional Port 2 connected to a DL06 PLC

