

CE EMC TEST REPORT

For

LED TUBE LIGHT

**MODEL:T8-12, T8-06, T8-09, T8-12, T8-15, T8-18, T5-06, T5-09, T5-12, T5-15,
T10-06, T10-09, T10-12, T10-15, T10-18**

Trade Mark: GLU

Test Report Number:TMC20130510EY01

Issued Date: May 10, 2013

Issued for:

Shenzhen GLU Lighting Co., Ltd.

**F2, Bldg A, NO.3 Yushan Industrial Area, Shiyan Town, Bao'an District, Shenzhen,
P.R. China 518108**

Issued By:

TMC Rheinland Testing Services Corp Limited

**1408, 14 /F, Block B, Chinto Technology Building, Minzhi Street, Longhua District,
Shenzhen, Guangdong, P.R. China**

Tel: 86-755- 86642861

Fax: 86-755-86642996

<http://www.tmc-lab.com>

Note: *This report shall not be reproduced except in full, without the written approval of TMC Rheinland Testing Services Corp Limited This document may be altered or revised by TMC Rheinland Testing Services Corp Limited personnel only, and shall be noted in the revision section of the document. The test results in the report only apply to the tested sample.*

Revision History Of Report

Rev.	Issue No.	Revisions	Effect Page	Revised By
00	TMC20130426EY01	Initial Issue	ALL	Lemon

TABLE OF CONTENTS

1 TEST CERTIFICATION	4
2 TEST RESULT SUMMARY	5
3 EUT DESCRIPTION	6
4 TEST METHODOLOGY	7
5 SETUP OF EQUIPMENT UNDER TEST.....	8
6 FACILITIES AND ACCREDITATIONS.....	9
6.1. FACILITIES.....	9
6.2. MEASUREMENT UNCERTAINTY	9
7 EMISSION TEST	10
7.1. CONDUCTED EMISSION MEASUREMENT	10
7.1.3. TEST PROCEDURES	11
7.1.4. TEST SETUP.....	12
7.2. RADIATED ELECTROMAGNETIC DISTURBANCE	15
7.2.3. TEST PROCEDURE.....	16
7.2.5 TEST RESULTS.....	17
7.3. RADIATED EMISSION MEASUREMENT	18
7.3.4. TEST SETUP.....	20
8 IMMUNITY TEST.....	23
8.1. GENERAL DESCRIPTION.....	23
8.2. GENERAL PERFORMANCE CRITERIA DESCRIPTION	24
8.3. ELECTROSTATIC DISCHARGE (ESD).....	25
8.3.3. TEST PROCEDURE.....	26
8.3.4. TEST SETUP.....	27
8.3.5. TEST RESULTS.....	28
8.4. RADIATED, RADIO-FREQUENCY, ELECTROMAGNETIC FIELD (RS)	29
8.4.3. TEST PROCEDURE.....	29
8.4.4. TEST SETUP.....	30
8.4.5. TEST RESULTS.....	31
8.5. ELECTRICAL FAST TRANSIENT (EFT)	32
8.5.4. TEST SETUP.....	33
8.5.5. TEST RESULTS.....	34
8.6. SURGE IMMUNITY TEST.....	35
8.6.3. TEST PROCEDURE.....	36
8.6.4. TEST SETUP.....	36
8.6.5. TEST RESULTS.....	37
8.7. CONDUCTED RADIO FREQUENCY DISTURBANCES (CS)	38
8.7.3. TEST PROCEDURE.....	39
8.7.4. TEST SETUP.....	39
8.7.5. TEST RESULTS.....	40
8.8. POWER FREQUENCY MAGNETIC FIELD.....	41
8.8.4. TEST SETUP.....	42
8.8.5. TEST RESULTS.....	42
8.9. VOLTAGE DIPS & VOLTAGE INTERRUPTIONS	43
8.9.4. TEST SETUP.....	44
8.9.5. TEST RESULTS.....	44
9 PHOTOGRAPHS OF EUT.....	45

1 TEST CERTIFICATION

Product:	LED TUBE LIGHT
Model:	T8-12, T8-06, T8-09, T8-12, T8-15, T8-18, T5-06, T5-09, T5-12, T5-15, T10-06, T10-09, T10-12, T10-15, T10-18
Trade Mark :	GLU
Applicant:	Shenzhen GLU Lighting Co., Ltd. F2, Bldg A, NO.3 Yushan Industrial Area, Shiyan Town, Bao'an District, Shenzhen, P.R. China 518108
Manufacturer:	Shenzhen GLU Lighting Co., Ltd. F2, Bldg A, NO.3 Yushan Industrial Area, Shiyan Town, Bao'an District, Shenzhen, P.R. China 518108
Tested:	May 10, 2013
Test Voltage:	AC 230V/50Hz
Applicable Standards:	EN 55015:2006+A1:2007+A2:2009 EN 61547:2009 EN 61000-3-2:2006+A1:2009 EN 61000-3-3:2008

Deviation from Applicable Standard
None

The above equipment has been tested by TMC Rheinland Testing Services Corp Limited and found compliance with the requirements set forth in the technical standards mentioned above. The results of testing in this report apply only to the product/system, which was tested. Other similar equipment will not necessarily produce the same results due to production tolerance and measurement uncertainties.

Tested By: Davis Zhou
 (Davis Zhou)

Date: May 10, 2013

Check By: Mike Zhao
 (Mike Zhao)

Date: May 10, 2013

Approved By: _____
 (Lemon)

Date: May 10, 2013

2 TEST RESULT SUMMARY

EMISSION			
Standard	Item	Result	Remarks
EN 55015:2006+A1:2007 +A2:2009	Conducted (Main Port)	PASS	Meet limit
	Radiated Electromagnetic Disturbance	PASS	Meet limit
	Radiated	PASS	Meet limit
EN 61000-3-2:2006+A1:2009	Harmonic current emissions	N/A	N/A
EN 61000-3-3:2008	Voltage fluctuations & flicker	N/A	N/A

IMMUNITY [EN 61547: 2009]			
Standard	Item	Result	Remarks
EN 61000-4-2:2009	ESD	PASS	Meets the requirements of Performance Criterion B
EN 61000-4-3:2006	RS	PASS	Meets the requirements of Performance Criterion A
EN 61000-4-4:2004+A1:2010	EFT	PASS	Meets the requirements of Performance Criterion B
EN 61000-4-5:2006	Surge	PASS	Meets the requirements of Performance Criterion B
EN 61000-4-6:2009	CS	PASS	Meets the requirements of Performance Criterion A
EN 61000-4-8: 2010	PFFM	PASS	Meets the requirements
EN 61000-4-11:2004	Voltage dips & voltage variations	PASS	Meets the requirements of Voltage dips and variations 1) 30% reduction performance Criterion C 2) 100% reduction performance Criterion B

- Note:**
1. The test result judgment is decided by the limit of test standard
 2. The information of measurement uncertainty is available upon the customer's request.

3 EUT DESCRIPTION

Product	LED TUBE LIGHT
Model	T8-12
Applicant	Shenzhen GLU Lighting Co., Ltd.
Housing material	Metal & Plastic
EUT Type	<input checked="" type="checkbox"/> Engineering Sample. <input type="checkbox"/> Product Sample, <input type="checkbox"/> Mass Product Sample.
Serial Number	N/A
EUT Power Rating	AC 220-240V
AC Line	N/A

I/O PORT

I/O PORT TYPES	Q'TY	TESTED WITH
N/A	N/A	N/A

Model list and Models difference

N/A

4 TEST METHODOLOGY

4.1. DECISION OF FINAL TEST MODE

The EUT was tested together with the thereafter additional components, and a configuration, which produced the worst emission levels, was selected and recorded in this report.

The following test mode(s) were scanned during the preliminary test:

Pre-Test Mode		
Emission	Conducted Emission	Mode: Lighting
	Radiated Electromagnetic Disturbance	Mode: Lighting
	Radiated Emission	Mode: Lighting
Immunity		Mode: Lighting

After the preliminary scan, the following test mode was found to produce the highest emission level.

The Worst Mode		
Emission	Conducted Emission	Mode: Lighting
	Radiated Electromagnetic Disturbance	Mode: Lighting
	Radiated Emission	Mode: Lighting
Immunity		Mode: Lighting

4.2. EUT SYSTEM OPERATION

1. Set up EUT with the support equipments.
2. Make sure the EUT work normally during the test.

5 SETUP OF EQUIPMENT UNDER TEST

5.1. DESCRIPTION OF SUPPORT UNITS

The EUT has been tested as an independent unit together with other necessary accessories or support units. The following support units or accessories were used to form a representative test configuration during the tests.

No.	Equipment	Model No.	Serial No.	FCC ID	Trade Name	Data Cable	Power Cord
1.	N/A	N/A	N/A	N/A	N/A	N/A	N/A

Note:

- 1) All the equipment/cables were placed in the worst-case configuration to maximize the emission during the test.
- 2) Grounding was established in accordance with the manufacturer's requirements and conditions for the intended use.

5.2. CONFIGURATION OF SYSTEM UNDER TEST

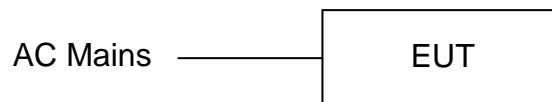

(EUT: LED TUBE LIGHT)

6 FACILITIES AND ACCREDITATIONS

6.1. FACILITIES

All measurement facilities used to collect the measurement data are located at

TMC Rheinland Testing Services Corp Limited

Room 1408, 14 Floor, B block, Chinto Technology Building, Minzhi Avenue, Minzhi Street, Longhua New District, Shenzhen, Guangdong, P.R. China

The sites are constructed in conformance with the requirements of ANSI C63.4 and CISPR Publication 15. All receiving equipment conforms to CISPR Publication 16-1, "Radio Interference Measuring Apparatus and Measurement Methods."

6.2. MEASUREMENT UNCERTAINTY

Where relevant, the following measurement uncertainty levels have been estimated for tests performed on the EUT as specified in CISPR 16-4-2:

Measurement	Frequency		Uncertainty
Conducted emissions	9kHz~30MHz		+/- 3.59dB
Radiated electromagnetic	9kHz~30MHz		+/- 4.77dB
Radiated emissions	Horizontal	30MHz ~ 230MHz	+/- 4.77dB
		230MHz ~300MHz	+/- 4.93dB
	Vertical	30MHz ~ 230MHz	+/- 5.04dB
		230MHz ~300MHz	+/- 4.93dB

This uncertainty represents an expanded uncertainty expressed at approximately the 95% confidence level using a coverage factor of k=2.

7 EMISSION TEST

7.1. CONDUCTED EMISSION MEASUREMENT

7.1.1. LIMITS

FREQUENCY (MHz)	LIMITS(dBuV)	
	Quasi-peak	Average
0.009-0.05	110	N/A
0.05-0.15	90 - 80	N/A
0.15 - 0.5	66 - 56	56 - 46
0.50 - 5.0	56	46
5.0 - 30.0	60	50

NOTE:

- (1) The lower limit shall apply at the transition frequencies.
- (2) The limit decreases in line with the logarithm of the frequency in the range of 0.15 to 0.50 MHz.
- (3) All emanations from EUT or system shall not exceed the level of field strengths specified above.

7.1.2. TEST INSTRUMENTS

Conducted Emission Shielding Room Test Site (843)				
Name of Equipment	Manufacturer	Model	Serial Number	Calibration Due
EMI Test Receiver	R&S	ESCI	100005	09/24/2013
LISN	AFJ	LS16	16010222119	09/29/2013
LISN(EUT)	Mestec	AN3016	04/10040	09/28/2013

NOTE:

- (1) The calibration interval of the above test instruments is 12 months and the calibrations are traceable to international system unit (SI).
- (2). N.C.R = No Calibration Request.

7.1.3. TEST PROCEDURES

Procedure of Preliminary Test

The EUT and Support equipment, if needed, was set up as per the test configuration to simulate typical usage per the user's manual. When the EUT is a tabletop system, a wooden table with a height of 0.8 meters is used and is placed on the ground plane. When the EUT is a floor standing equipment, it is placed on the ground plane, which has a 3-12 mm non-conductive covering to insulate the EUT from the ground plane.

The EUT test program was started. Emissions were measured on each current carrying line of the EUT using an EMI Test Receiver connected to the LISN powering the EUT.

The Receiver scanned from 9 kHz to 30MHz for emissions in each of the test modes.

During the above scans, the emissions were maximized by cable manipulation.

The test mode(s) described in Item 3.1 were scanned during the preliminary test.

After the preliminary scan, we found the test mode described in Item 3.1 producing the highest emission level.

The EUT configuration and cable configuration of the above highest emission levels were recorded for reference of the final test.

Procedure of Final Test

EUT and support equipment were set up on the test bench as per the configuration with highest emission level in the preliminary test.

A scan was taken on both power lines, Line 1 and Line 2, recording at least the six highest emissions. Emission frequency and amplitude were recorded into a computer in which correction factors were used to calculate the emission level and compare reading to the applicable limit.

The test data of the worst-case condition(s) was recorded.

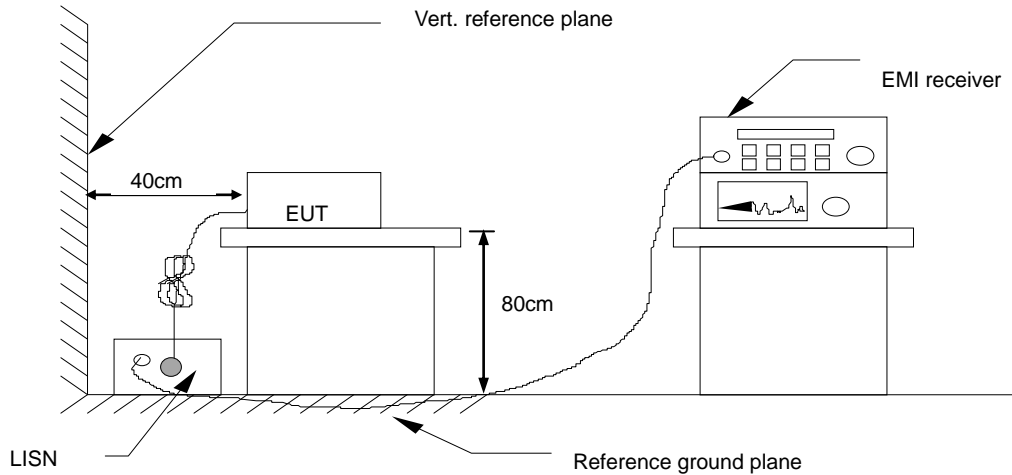

For the actual test configuration, please refer to the related item – Photographs of the Test Configuration.

7.1.5. TEST RESULTS

Model No.	T8-12	6dB Bandwidth	10 KHz
Environmental Conditions	26°C, 60% RH	Test Mode	Lighting
Detector Function	Peak / Quasi-peak/AV	Test Result	Pass
Test By	Davis Zhou		

NOTE:

L1 = Line One (Live Line) / L2 = Line Two (Neutral Line).

“---” denotes the emission level was or more than 2dB below the Average limit, so no re-check anymore.

Freq. = Emission frequency in MHz

Reading level(dBuV) = Receiver reading

Corr. Factor (dB) = attenuator + Cable loss

Level (dBuV) = Reading level(dBuV) + Corr. Factor (dB)

Limit (dBuV) = Limit stated in standard

Margin (dB) = Level (dBuV) – Limits (dBuV)

Q.P.=Quasi-Peak

Please refer to following diagram for individual

Conducted Emission Measurement

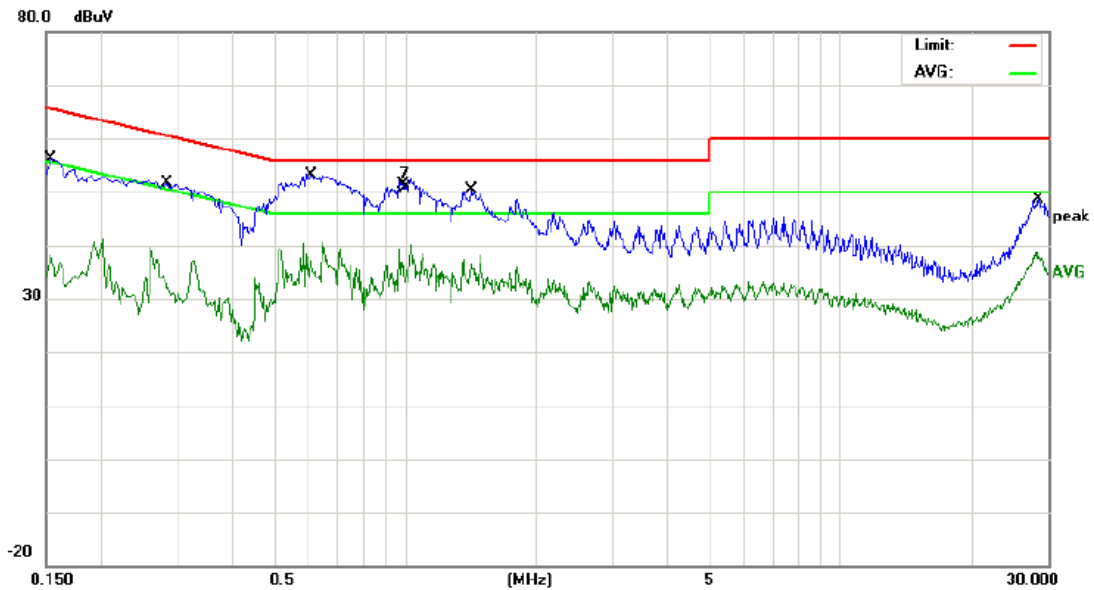

Site: 843 Shielded Room
 Limit: EN55015 Conduction(QP)
 EUT: LED tube
 M/N: P8-12
 Mode: Lighting
 Note:

Phase: **N**
 Power: AC 230V/50Hz
 Temperature: 26
 Humidity: 60 %

No.	Mk.	Freq.	Reading Level	Correct Factor	Measurement	Limit	Over	Detector	Comment
		MHz	dBuV	dB	dBuV	dBuV	dB		
1		0.1556	45.64	10.43	56.07	65.69	-9.62	QP	
2		0.1556	26.04	10.43	36.47	55.69	-19.22	AVG	
3		0.2860	41.01	10.60	51.61	60.64	-9.03	QP	
4		0.2860	21.62	10.60	32.22	50.64	-18.42	AVG	
5	*	0.6020	42.04	10.70	52.74	56.00	-3.26	QP	
6		0.6020	25.85	10.70	36.55	46.00	-9.45	AVG	
7		0.9980	39.98	10.75	50.73	56.00	-5.27	peak	
8		0.9980	24.68	10.75	35.43	46.00	-10.57	AVG	
9		1.4380	38.74	10.73	49.47	56.00	-6.53	QP	
10		1.4380	24.98	10.73	35.71	46.00	-10.29	AVG	
11		28.5620	38.10	10.59	48.69	60.00	-11.31	QP	
12		28.5620	27.03	10.59	37.62	50.00	-12.38	AVG	

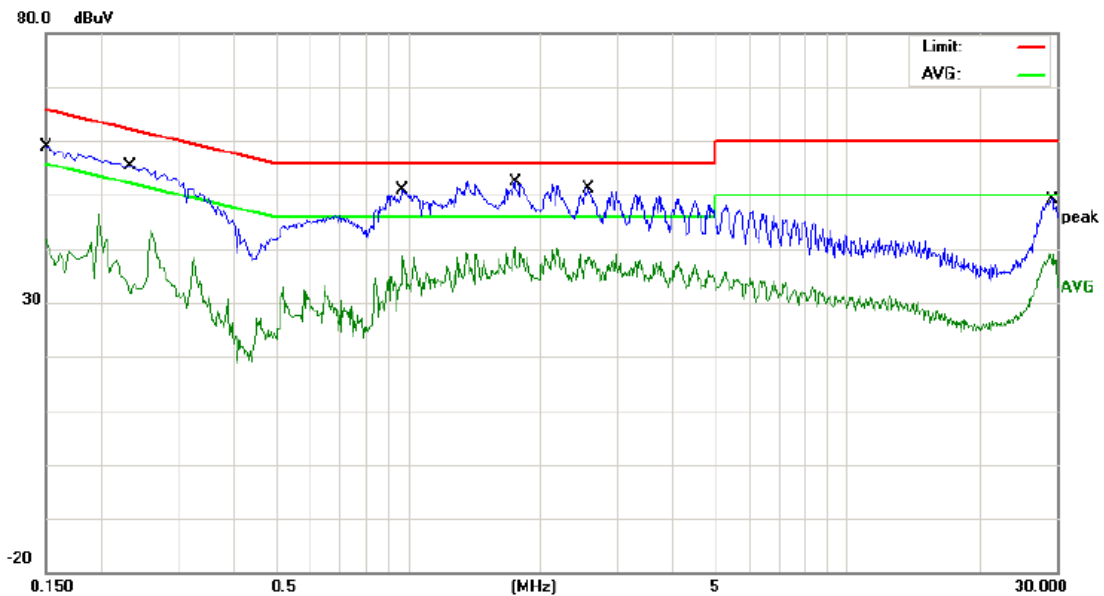
Conducted Emission Measurement

Site 843 Shielded Room Phase: **L1** Temperature: 26
 Limit: EN55015 Conduction(QP) Power: AC 230V/50Hz Humidity: 60 %
 EUT: LED tube
 M/N: P8-12
 Mode: Lighting
 Note:

No.	Mk.	Freq. MHz	Reading Level dBuV	Correct Factor dB	Measure- ment dBuV	Limit dBuV	Over dB	Detector	Comment
1		0.1500	48.39	10.45	58.84	65.99	-7.15	QP	
2		0.1500	31.24	10.45	41.69	55.99	-14.30	AVG	
3		0.2353	44.92	10.42	55.34	62.26	-6.92	QP	
4		0.2353	21.98	10.42	32.40	52.26	-19.86	AVG	
5		0.9820	40.13	10.79	50.92	56.00	-5.08	QP	
6		0.9820	26.87	10.79	37.66	46.00	-8.34	AVG	
7	*	1.7700	40.49	10.72	51.21	56.00	-4.79	QP	
8		1.7700	26.70	10.72	37.42	46.00	-8.58	AVG	
9		2.5900	40.39	10.69	51.08	56.00	-4.92	QP	
10		2.5900	27.06	10.69	37.75	46.00	-8.25	AVG	
11		29.3180	38.66	10.59	49.25	60.00	-10.75	QP	
12		29.3180	27.06	10.59	37.65	50.00	-12.35	AVG	

7.2. RADIATED ELECTROMAGNETIC DISTURBANCE

7.2.1. LIMITS

Frequency	Limits for loop diameter dB(μ A)*		
	2m	3m	4m
9KHz-70KHz	88	81	75
70KHz-150KHz	88-58**	81-51**	75-45**
150KHz-3.0MHz	58-22**	51-22**	45-16**
3.0MHz-30MHz	22	15-16***	9-12***

* At the transition frequency, the lower limit applies.

** Decreasing linearly with the logarithm of the frequency.

*** Increasing linearly with the logarithm of the frequency.

Note: In Japan, the limits for frequencies 9KHz to 150KHz do not apply.

7.2.2. TEST INSTRUMENTS

Radiated Electromagnetic Emission Test Site				
Name of Equipment	Manufacturer	Model	Serial Number	Calibration Due
EMI Test Receiver	R&S	ESCI	100005	09/24/2013
Triple-Loop Antenna	EVERFINE	LLA-2	N/A	07/15/2013

NOTE: (1). The calibration interval of the above test instruments is 12 months and the calibrations are traceable to international system unit (SI).

(2). N.C.R = No Calibration Request.

7.2.3. TEST PROCEDURE

In the frequency range 9KHz to 30MHz the interference capability of the magnetic field component of the radiation of Equipment Under Test (EUT) can be determined by using a special Loop Antenna System (LAS). In the LAS, this capability is measured in terms of the currents induced by the magnetic field in the loop antennas of the LAS. The LAS allows indoor measurement.

The LAS consists of three circular, mutually perpendicular Large-Loop Antennas (LLAs), having a diameter of 2 m, supported by a non-metallic base. A 50Ω coaxial cable between the current probe of an LLA and the coaxial switch, and between this switch and the measuring equipment, shall have surface transfer impedance smaller than 10mΩ/m at 100KHz and 1mΩ/m at 10MHz.

The distance between the outer diameter of the loop antenna system and nearby objects, such as floor and walls, shall be at least 0.5m as per CISPR 15/ EN55015.

The EUT is positioned in the center of the LAS (To avoid unwanted capacitive coupling between the EUT and the LAS, the maximum dimensions of the EUT are limited so that the distance between the EUT and an LLA is at least 0.2m). Cables should be routed together and leave the loop volume in the same octant of the cell, no closer than 0.4m to the LAS loops.

The induced current in the loop antenna is measured by means of a current probe(1V/A) and the CISPR measuring receiver(or equivalent). By means of a coaxial switch, the three field direction(X, Y, Z) can be measured in sequence, and recorded at least the six highest emission. Each value shall fulfill the requirement given.

The test data of the worst-case condition(s) was recorded.

7.2.4. TEST SETUP

For the actual test configuration, please refer to the related item – Photographs of the Test Configuration.

Model No.	T8-12	Test Mode	Lighting
Environmental Conditions	26°C,60% RH	6dB Bandwidth	10 KHz
Antenna Pole	X,Y,Z	Antenna Diameter	2m
Detector Function	Peak	Test Result	Pass
Test By	Davis Zhou		

7.2.5 TEST RESULTS

req. = Emission frequency in MHz
 Reading level (dBuA) = Receiver reading
 Corr. Factor (dB) = Antenna factor + Cable loss
 Measurement (dBuA) = Reading level (dBuA) + Corr. Factor (dB)
 Limit (dBuA) = Limit stated in standard
 Margin (dB) = Measurement (dBuA) – Limits (dBuA)

7.3. RADIATED EMISSION MEASUREMENT

7.3.1. LIMITS

FREQUENCY (MHz)	dBuV/m (At 3m)
30 ~ 230	40
230 ~ 300	47

NOTE: (1) The lower limit shall apply at the transition frequencies.
 (2) Emission level (dBuV/m) = 20 log Emission level (uV/m).

7.3.2. TEST INSTRUMENTS

Radiated Emission Test Site (966)				
Name of Equipment	Manufacturer	Model	Serial Number	Calibration Due
EMI Test Receiver	R&S	ESCI	100005	09/24/2013
Spectrum Analyzer	R&S	FSU	100114	07/14/2013
Pre Amplifier	H.P.	HP8447E	2945A02715	09/15/2013
Bilog Antenna	SUNOL Sciences	JB3	A021907	09/10/2013
Cable	TIME MICROWAVE	LMR-400	N-TYPE04	09/09/2013
System-Controller	CCS	N/A	N/A	N.C.R
Turn Table	CCS	N/A	N/A	N.C.R
Antenna Tower	CCS	N/A	N/A	N.C.R

NOTE: 1. The calibration interval of the above test instruments is 12 months and the calibrations are traceable to international system unit (SI).
 2. N.C.R = No Calibration Request.

7.3.3. TEST PROCEDURE

Procedure of Preliminary Test

The equipment was set up as per the test configuration to simulate typical usage per the user's manual. When the EUT is a tabletop system, a wooden turntable with a height of 0.8 meters is used which is placed on the ground plane. When the EUT is a floor standing equipment, it is placed on the ground plane which has a 3-12 mm non-conductive covering to insulate the EUT from the ground plane.

Support equipment, if needed, was placed as per EN 55015.

All I/O cables were positioned to simulate typical usage as per EN 55015.

Mains cables, telephone lines or other connections to auxiliary equipment located outside the test are shall drape to the floor, be fitted with ferrite clamps or ferrite tubes placed on the floor at the point where the cable reaches the floor and then routed to the place where they leave the turntable. No extension cords shall be used to mains receptacle.

The antenna was placed at 3 meter away from the EUT as stated in EN 55015. The antenna connected to the Spectrum Analyzer via a cable and at times a pre-amplifier would be used.

The Analyzer / Receiver quickly scanned from 30MHz to 300MHz. The EUT test program was started. Emissions were scanned and measured rotating the EUT to 360 degrees and positioning the antenna 1 to 4 meters above the ground plane, in both the vertical and the horizontal polarization, to maximize the emission reading level.

The test mode(s) described in Item 3.1 were scanned during the preliminary test:

After the preliminary scan, we found the test mode described in Item 3.1 producing the highest emission level. The EUT and cable configuration, antenna position, polarization and turntable position of the above highest emission level were recorded for the final test.

Procedure of Final Test

EUT and support equipment were set up on the turntable as per the configuration with highest emission level in the preliminary test.

The Analyzer / Receiver scanned from 30MHz to 300MHz. Emissions were scanned and measured rotating the EUT to 360 degrees, varying cable placement and positioning the antenna 1 to 4 meters above the ground plane, in both the vertical and the horizontal polarization, to maximize the emission reading level.

Recorded at least the six highest emissions. Emission frequency, amplitude, antenna position, polarization and turntable position were recorded into a computer in which correction factors were used to calculate the emission level and compare reading to the applicable limit and only Q.P. reading is presented.

The test data of the worst-case condition(s) was recorded.

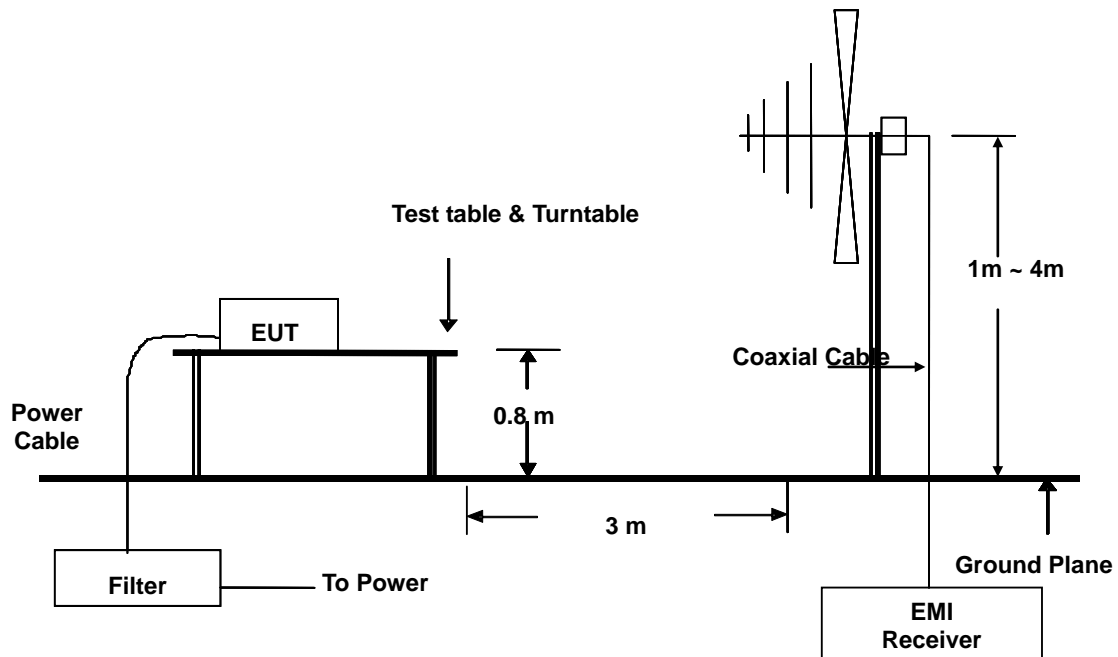

For the actual test configuration, please refer to the related item – Photographs of the Test Configuration.

Model No.	T8-12	Test Mode	Lighting
Environmental Conditions	26°C, 55% RH	6dB Bandwidth	120 KHz
Antenna Pole	Vertical / Horizontal	Antenna Distance	3m
Detector Function	Peak / Quasi-peak	Tested by	Davis Zhou

7.3.5 TEST RESULTS

Freq. = Emission frequency in MHz
 Reading level (dBuV) = Receiver reading
 Corr. Factor (dB) = Antenna factor + Cable loss
 Measurement (dBuV) = Reading level (dBuV) + Corr. Factor (dB)
 Limit (dBuV) = Limit stated in standard
 Margin (dB) = Measurement (dBuV) – Limits (dBuV)

Please refer to following diagram for individual

Radiated Emission Measurement

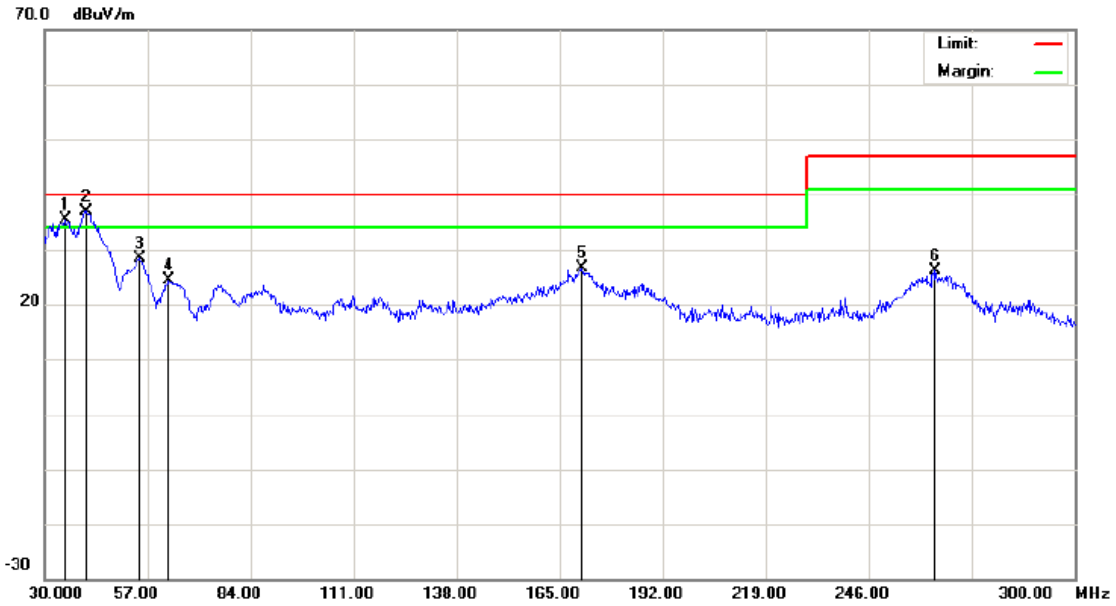

Site 966
Limit: EN55015_RE 3M
EUT: LED Tube Light
M/N: P8-12
Mode: Lighting
Note:

Polarization: **Vertical**
Power: AC 230V/50Hz
Distance: 3m

Temperature: 26
Humidity: 55 %

No.	Mk.	Freq. MHz	Reading Level dBuV	Correct Factor dB	Measurement dBuV/m	Limit dBuV/m	Over dB	Antenna Height cm	Table Degree degree	Detector	Comment
1	!	35.4000	39.31	-3.94	35.37	40.00	-4.63			peak	
2	*	40.8000	44.60	-7.69	36.91	40.00	-3.09			peak	
3		54.8400	38.58	-10.15	28.43	40.00	-11.57			peak	
4		62.6700	36.03	-11.54	24.49	40.00	-15.51			peak	
5		170.9400	30.32	-3.73	26.59	40.00	-13.41			peak	
6		263.2799	29.56	-3.45	26.11	47.00	-20.89			peak	

Radiated Emission Measurement

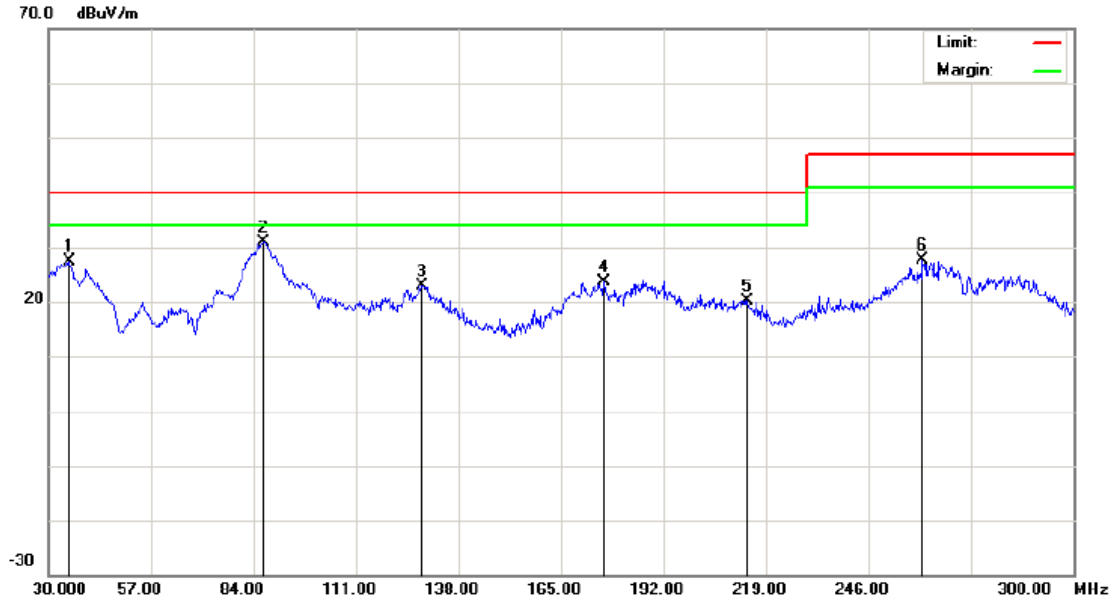

Site: 966
 Limit: EN55015_RE 3M
 EUT: LED Tube Light
 M/N: P8-12
 Mode: Lighting
 Note:

Polarization: *Horizontal*
 Power: AC 230V/50Hz
 Distance: 3m

Temperature: 26
 Humidity: 55 %

No.	Mk.	Freq. MHz	Reading Level dBuV	Correct Factor dB	Measure- ment dBuV/m	Limit dBuV/m	Over dB	Antenna Height cm	Table Degree	Comment
1		35.4000	32.65	-5.18	27.47	40.00	-12.53	QP		
2	*	86.7000	40.44	-9.63	30.81	40.00	-9.19	QP		
3		128.2800	28.64	-5.76	22.88	40.00	-17.12	QP		
4		176.3400	29.62	-5.94	23.68	40.00	-16.32	QP		
5		214.1400	26.74	-6.49	20.25	40.00	-19.75	QP		
6		260.3100	32.59	-5.01	27.58	47.00	-19.42	QP		

8 IMMUNITY TEST

8.1. GENERAL DESCRIPTION

Product Standard	EN 61547: 2009	
	Test Type	Minimum Requirement
Basic Standard, Specification, and Performance Criterion required	EN 61000-4-2	Electrostatic Discharge – ESD: 8kV air discharge, 4kV Contact discharge, Performance Criterion B
	EN 61000-4-3	Radio-Frequency Electromagnetic Field Susceptibility Test – RS: 80 ~1000 MHz, 3V/m, 80% AM(1kHz), Performance Criterion A
	EN 61000-4-4	Electrical Fast Transient/Burst - EFT, Power line: 1kV, Signal line: 0.5kV, Performance Criterion B
	EN 61000-4-5	Surge Immunity Test: 1.2/50 us Open Circuit Voltage, 8 /20 us Short Circuit Current, Power Port ~ Line to line: 0.5kV, Line to ground: 1kV (to self-ballasted lamps and semi-luminaires;luminaires and independent auxiliaries which are less than 25W) Power Port ~ Line to line: 1kV, Line to ground: 2kV (to luminaires and independent auxiliaries which are more than 25W) Signal Port : 0.5kV Performance Criterion B
	EN 61000-4-6	Conducted Radio Frequency Disturbances Test –CS: 0.15 ~ 80 MHz, 3Vrms, 80% AM, 1kHz, Performance Criterion A
	EN 61000-4-8	Power frequency magnetic field immunity test 50 Hz, 3A/m Performance Criterion A
	EN 61000-4-11	Voltage Dips and Interruptions: ii) 30% reduction for 10 period, Performance Criterion C 100% reduction for 0.5 period Performance Criterion B

8.2. GENERAL PERFORMANCE CRITERIA DESCRIPTION

Criteria A:	During the test no change of the luminous intensity shall be observed and the regulating control, if any, shall operate during the test as intended.
Criteria B:	During the test the luminous intensity may change to any value. After the test the luminous intensity shall be restored to its initial value within 1 min. Regulating controls need not function during the test, but after the test the mode of the control shall be the same as before the test provided that during the test no mode changing commands were given.
Criteria C:	During and after the test any change of the luminous intensity is allowed and the lamp(s) may be extinguished. After the test, within 30 min, all functions shall return to LIGHTING if necessary by temporary interruption of the mains supply and/or operating the regulating control. Additional requirement for lighting equipment incorporating a starting device: After the test the lighting equipment is switched off. After half an hour it is switched on again. The lighting equipment shall start and operate as intended.

8.3. ELECTROSTATIC DISCHARGE (ESD)

8.3.1. TEST SPECIFICATION

Basic Standard:	EN 61000-4-2
Discharge Impedance:	330ohm
Charging Capacity:	150pF
Discharge Voltage:	Air Discharge: 8 kV (Direct) Contact Discharge: 4 kV (Direct/Indirect)
Polarity:	Positive & Negative
Number of Discharge:	Minimum 10 times at each test point
Discharge Mode:	1 time/s
Performance Criterion:	B

8.3.2. TEST INSTRUMENT

IMMUNITY SHIELDED ROOM				
Name of Equipment	Manufacturer	Model	Serial Number	Calibration Due
ESD 2000	EMC PARTNER	ESD2000	182	07/11/2013

NOTE: The calibration interval of the above test instruments is 12 months and the calibrations are traceable to international system unit (SI).

8.3.3. TEST PROCEDURE

The discharges shall be applied in two ways:

a) Contact discharges to the conductive surfaces and coupling planes:

Twenty dischargers (10 with positive and 10 with negative polarity) shall be applied on each accessible metallic part of the enclosure, terminals are excluded. In case of a non-conductive enclosure, dischargers shall be applied on the horizontal or vertical coupling planes. Test shall be performed at a maximum repetition rate of one discharge per second.

b) Air discharges at slots and apertures and insulating surfaces:

On those parts of the EUT where it is not possible to perform contact discharge testing, the equipment should be investigated to identify user accessible points where breakdown may occur. Such points are tested using the air discharge method. This investigation should be restricted to those area normally handled by the user. A minimum of 10 single air discharges shall be applied to the selected test point for each such area.

The basic test procedure was in accordance with IEC 61000-4-2:

- a) The EUT was located 0.1 m minimum from all side of the **HCP** (dimensions 1.6m x 0.8m).
- b) The support units were located another table 30 cm away from the EUT, but direct support unit was/were located at same location as EUT on the HCP and keep at a distance of 10 cm with EUT.
- c) The time interval between two successive single discharges was at least 1 second.
- d) Contact discharges were applied to the non-insulating coating, with the pointed tip of the generator penetrating the coating and contacting the conducting substrate.
- e) Air discharges were applied with the round discharge tip of the discharge electrode approaching the EUT as fast as possible (without causing mechanical damage) to touch the EUT. After each discharge, the ESD generator was removed from the EUT and re-triggered for a new single discharge. The test was repeated until all discharges were complete.
- f) At least ten single discharges (in the most sensitive polarity) were applied at the front edge of each **HCP** opposite the center point of each unit of the EUT and 0.1 meters from the front of the EUT. The long axis of the discharge electrode was in the plane of the **HCP** and perpendicular to its front edge during the discharge.
- g) At least ten single discharges (in the most sensitive polarity) were applied to the center of one vertical edge of the **Vertical Coupling Plane (VCP)** in sufficiently different positions that the four faces of the EUT were completely illuminated. The **VCP** (dimensions 0.5m x 0.5m) was placed vertically to and 0.1 meters from the EUT.

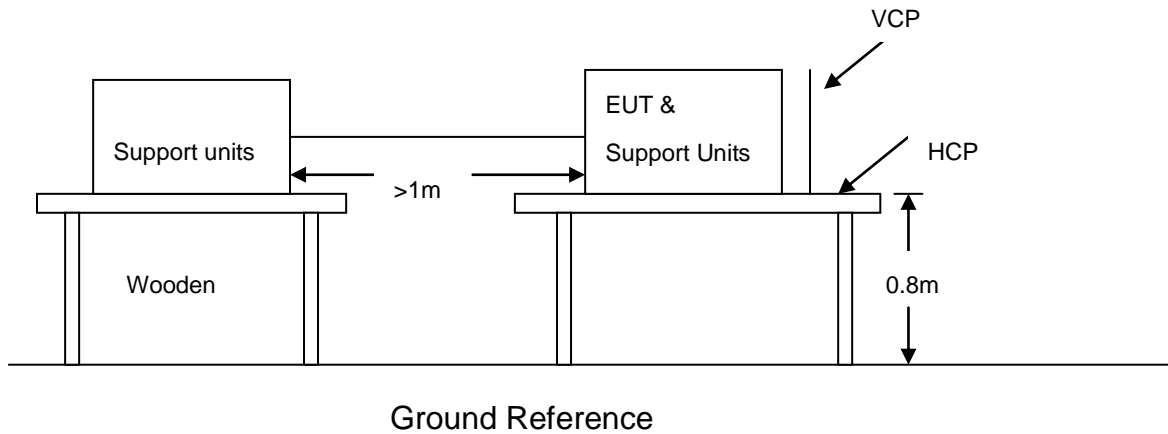

For the actual test configuration, please refer to the related item – Photographs of the Test Configuration.

NOTE:

TABLE-TOP EQUIPMENT

The configuration consisted of a wooden table 0.8 meters high standing on the **Ground Reference Plane**. The **GRP** consisted of a sheet of aluminum at least 0.25mm thick, and 2.5 meters square connected to the protective grounding system. A **Horizontal Coupling Plane** (1.6m x 0.8m) was placed on the table and attached to the **GRP** by means of a cable with 940k total impedance. The equipment under test, was installed in a representative system as described in section 7 of EN 61000-4-2, and its cables were placed on the **HCP** and isolated by an insulating support of 0.5mm thickness. A distance of 1-meter minimum was provided between the EUT and the walls of the laboratory and any other metallic structure.

FLOOR-STANDING EQUIPMENT

The equipment under test was installed in a representative system as described in section 7 of IEC 61000-4-2, and its cables were isolated from the Ground Reference Plane by an insulating support of 0.1-meter thickness. The GRP consisted of a sheet of aluminum that is at least 0.25mm thick, and 2.5 meters square connected to the protective grounding system and extended at least 0.5 meters from the EUT on all sides.

8.3.5. TEST RESULTS

Temperature:	26°C	Humidity	55% RH
Pressure	996mbar	Test result	Pass
Test mode	Lighting	Test By	Davis Zhou

Air Discharge					
Test Points	Test Levels	Results			
	± 8 kV	Pass	Fail	Performance Criterion	Observation
Surface 4Points	<input checked="" type="checkbox"/>	<input checked="" type="checkbox"/>	<input type="checkbox"/>	B	Note <input type="checkbox"/> 1 <input checked="" type="checkbox"/> 2

Contact Discharge					
Test Points	Test Levels	Results			
	± 4 kV	Pass	Fail	Performance Criterion	Observation
Metal 4Points	<input checked="" type="checkbox"/>	<input checked="" type="checkbox"/>	<input type="checkbox"/>	B	Note <input type="checkbox"/> 1 <input checked="" type="checkbox"/> 2
HCP 4Points	<input checked="" type="checkbox"/>	<input checked="" type="checkbox"/>	<input type="checkbox"/>	B	Note <input type="checkbox"/> 1 <input checked="" type="checkbox"/> 2
VCP 4Points	<input checked="" type="checkbox"/>	<input checked="" type="checkbox"/>	<input type="checkbox"/>	B	Note <input type="checkbox"/> 1 <input checked="" type="checkbox"/> 2

NOTE: 1. There was no change compared with initial operation during the test.
 2. The loss of function of the EUT during the test and it was recovered by itself operation after the test.

8.4. RADIATED, RADIO-FREQUENCY, ELECTROMAGNETIC FIELD (RS)

8.4.1. TEST SPECIFICATION

Basic Standard:	EN 61000-4-3
Frequency Range:	80 MHz ~1000 MHz,
Field Strength:	3 V/m
Modulation:	1kHz Sine Wave, 80%, AM Modulation
Frequency Step:	1 % of preceding frequency value
Polarity of Antenna:	Horizontal and Vertical
Test Distance:	3 m
Antenna Height:	1.5m
Performance Criterion:	A

8.4.2. TEST INSTRUMENT

743 RS Chamber				
Name of Equipment	Manufacturer	Model	Serial Number	Calibration Due
Signal Generator	Maconi	2022D	119246/003	09/09/2013
Power Amplifier	M2S	A00181-1000	9801-112	09/09/2013
Power Amplifier	M2S	AC8113/ 800-250A	9801-179	09/09/2013
Power Antenna	SCHAFFNER	CBL6140A	1204	09/09/2013

NOTE: 1. The calibration interval of the above test instruments is 12 months and the calibrations are traceable to international system unit (SI).
 2. N.C.R.= No Calibration required

8.4.3. TEST PROCEDURE

The test procedure was in accordance with EN 61000-4-3

- The testing was performed in a fully anechoic chamber. The transmit antenna was located at a distance of 3 meters from the EUT.
- The frequency range is swept from 80 MHz to 1000 MHz, with the signal 80% amplitude modulated with a 1 kHz sine-wave. The rate of sweep did not exceed 1.5×10^{-3} decade/s, where the frequency range is swept incrementally; the step size was 1% of preceding frequency value.
- The dwell time at each frequency shall be not less than the time necessary for the EUT to be able to respond.
- The test was performed with the EUT exposed to both vertically and horizontally polarized fields on each of the four sides.

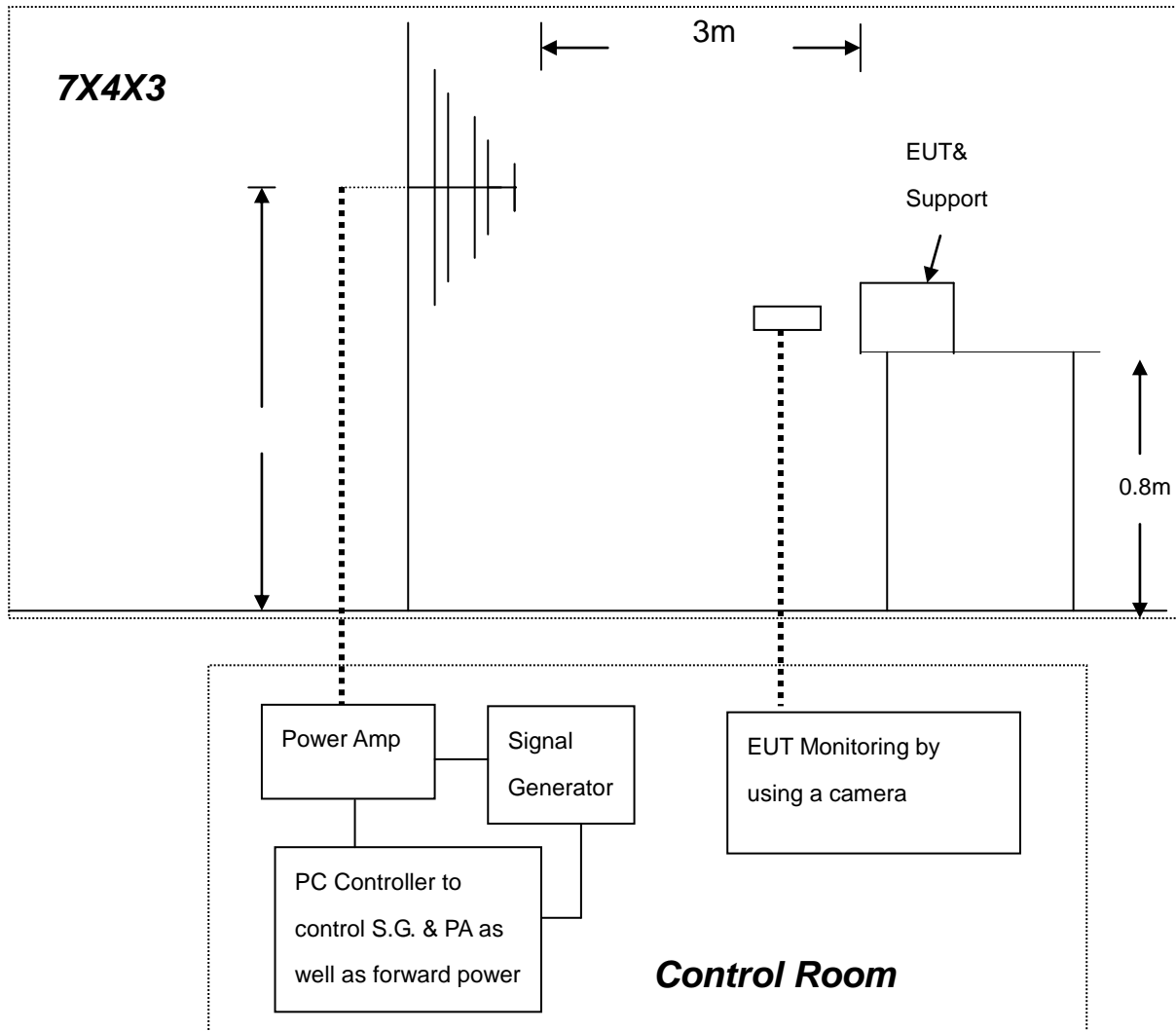

For the actual test configuration, please refer to the related item.

NOTE:

TABLETOP EQUIPMENT

The EUT installed in a representative system as described in section 7 of EN 61000-4-3 was placed on a non-conductive table 0.8 meters in height. The system under test was connected to the power and signal wire according to relevant installation instructions.

FLOOR STANDING EQUIPMENT

The EUT installed in a representative system as described in section 7 of IEC 61000-4-3 was placed on a non-conductive wood support 0.1 meters in height. The system under test was connected to the power and signal wire according to relevant installation instructions.

8.4.5. TEST RESULTS

Temperature:	26 °C	Humidity	55% RH
Pressure	996mbar	Test result	Pass
Test mode	Lighting	Test By	Davis Zhou

Frequency (MHz)	Polarity	Position	Field Strength (V/m)	Observation	Result
80 ~ 1000	V&H	Front	3	Note	PASS
80 ~ 1000	V&H	Rear	3	Note	PASS
80 ~ 1000	V&H	Left	3	Note	PASS
80 ~ 1000	V&H	Right	3	Note	PASS

NOTE: 1. There was no change compared with the initial operation during the test.

8.5. ELECTRICAL FAST TRANSIENT (EFT)

8.5.1. TEST SPECIFICATION

Basic Standard:	EN 61000-4-4
Test Voltage:	Power Line: 1 kV Signal/Control Line: 0.5 kV
Polarity:	Positive & Negative
Impulse Frequency:	5 kHz
Impulse Wave-shape:	5/50 ns
Burst Duration:	15 ms
Burst Period:	300ms
Test Duration:	Not less than 1 min.
Performance Criterion:	B

8.5.2. TEST INSTRUMENT

Immunity Shield Room				
Name of Equipment	Manufacturer	Model	Serial Number	Calibration Due
EMC PARTNER TRANSIENT 2000	EMC PARTNER	TRA2000	881	07/11/2013

NOTE: 1. The calibration interval of the above test instruments is 12 months and the calibrations are traceable to international system unit (SI).

2. N.C.R.= No Calibration required

8.5.3. TEST PROCEDURE

- Both positive and negative polarity discharges were applied.
- The length of the "hot wire" from the coaxial output of the EFT generator to the terminals on the EUT should not exceed 1 meter.
- The duration time of each test sequential was 1 minute.
- The transient/burst waveform was in accordance with EN 61000-4-4, 5/50ns.

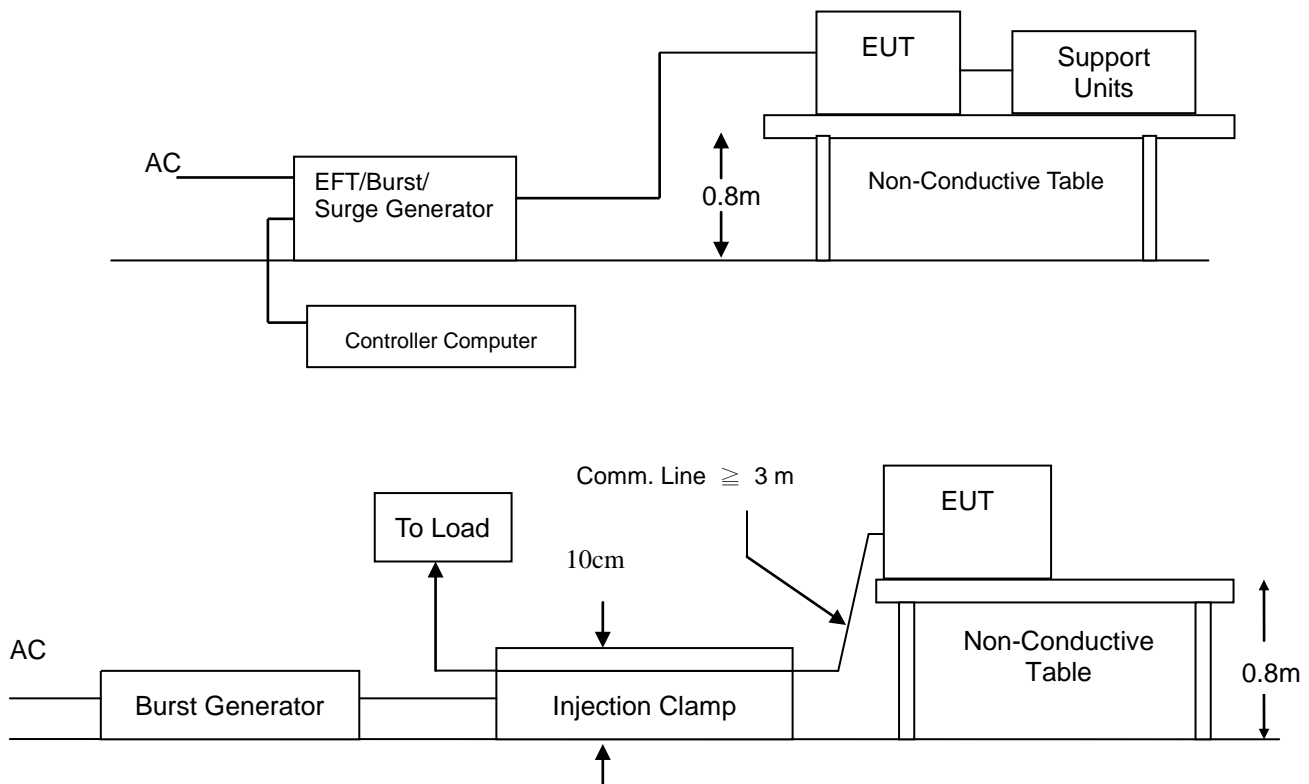

For the actual test configuration, please refer to the related item – Photographs of the Test Configuration.

NOTE:

TABLETOP EQUIPMENT

The configuration consisted of a wooden table (0.8m high) standing on the Ground Reference Plane. The GRP consisted of a sheet of aluminum (at least 0.25mm thick and 2.5m square) connected to the protective grounding system. A minimum distance of 0.5m was provided between the EUT and the walls of the laboratory or any other metallic structure.

FLOOR STANDING EQUIPMENT

The EUT installed in a representative system as described in section 7 of IEC 61000-4-4 and its cables, were isolated from the Ground Reference Plane by an insulating support that is 0.1-meter thick. The GRP consisted of a sheet of aluminum (at least 0.25mm thick and 2.5m square) connected to the protective grounding system.

8.5.5. TEST RESULTS

Temperature:	26°C	Humidity	55% RH
Pressure	996mbar	Test result	Pass
Test mode:	Lighting	Test By	Davis Zhou

Test Point	Polarity	Test Level (kV)	Performance Criterion	Observation	Result
L 1	+/-	1	B	Note <input type="checkbox"/> 1 <input checked="" type="checkbox"/> 2	PASS
L 2	+/-	1	B	Note <input type="checkbox"/> 1 <input checked="" type="checkbox"/> 2	PASS
L 1-L 2	+/-	1	B	Note <input type="checkbox"/> 1 <input checked="" type="checkbox"/> 2	PASS
PE	--	--	--	Note <input type="checkbox"/> 1 <input type="checkbox"/> 2	N/A
L – PE	--	--	--	Note <input type="checkbox"/> 1 <input type="checkbox"/> 2	N/A
N – PE	--	--	--	Note <input type="checkbox"/> 1 <input type="checkbox"/> 2	N/A
L – N – PE	--	--	--	Note <input type="checkbox"/> 1 <input type="checkbox"/> 2	N/A
RJ45 UTP cable	--	--	--	Note <input type="checkbox"/> 1 <input type="checkbox"/> 2	N/A

- NOTE:** 1. There was no change compared with initial operation during the test.
 2. The loss of function of the EUT during the test and it was recovered by itself operation after the test.

8.6. SURGE IMMUNITY TEST

8.6.1 TEST SPECIFICATION

Basic Standard:	EN 61000-4-5
Wave-Shape:	Combination Wave 1.2/50 us Open Circuit Voltage 8/20 us Short Circuit Current
Test Voltage:	Power line ~ line to line: 1 kV; line to ground: 2kV Telecommunication line: 1 kV;
Surge Input/Output:	Power Line: L1-L2 / L1-PE / L2-PE Telecommunication line: T-Ground / R-Ground
Generator Source Impedance:	2 ohm between networks 12 ohm between network and ground
Polarity:	Positive/Negative
Phase Angle:	0 /90 /180 /270
Pulse Repetition Rate:	1 time / min. (maximum)
Number of Tests:	5 positive and 5 negative at selected points
Performance Criterion:	B

8.6.2. TEST INSTRUMENT

Immunity Shield Room				
Name of Equipment	Manufacturer	Model	Serial Number	Calibration Due
EMC PARTNER TRANSIENT 2000	EMC PARTNER	TRA2000	881	07/11/2013

NOTE: 1. The calibration interval of the above test instruments is 12 months and the calibrations are traceable to international system unit (SI).
2. N.C.R.= No Calibration required

8.6.3. TEST PROCEDURE

a) For EUT power supply:

The surge is applied to the EUT power supply terminals via the capacitive coupling network. Decoupling networks are required in order to avoid possible adverse effects on equipment not under test that may be powered by the same lines, and to provide sufficient decoupling impedance to the surge wave. The power cord between the EUT and the coupling/decoupling networks was shorter than 2 meters in length.

b) For test applied to unshielded un-symmetrically operated interconnection lines of EUT:

The surge was applied to the lines via the capacitive coupling. The coupling / decoupling networks didn't influence the specified functional conditions of the EUT. The interconnection line between the EUT and the coupling/decoupling networks was shorter than 2 meters in length.

c) For test applied to unshielded symmetrically operated interconnection / telecommunication lines of EUT:

The surge was applied to the lines via gas arrestors coupling. Test levels below the ignition point of the coupling arrestor were not specified. The interconnection line between the EUT and the coupling/decoupling networks was shorter than 2 meters in length.

8.6.4. TEST SETUP

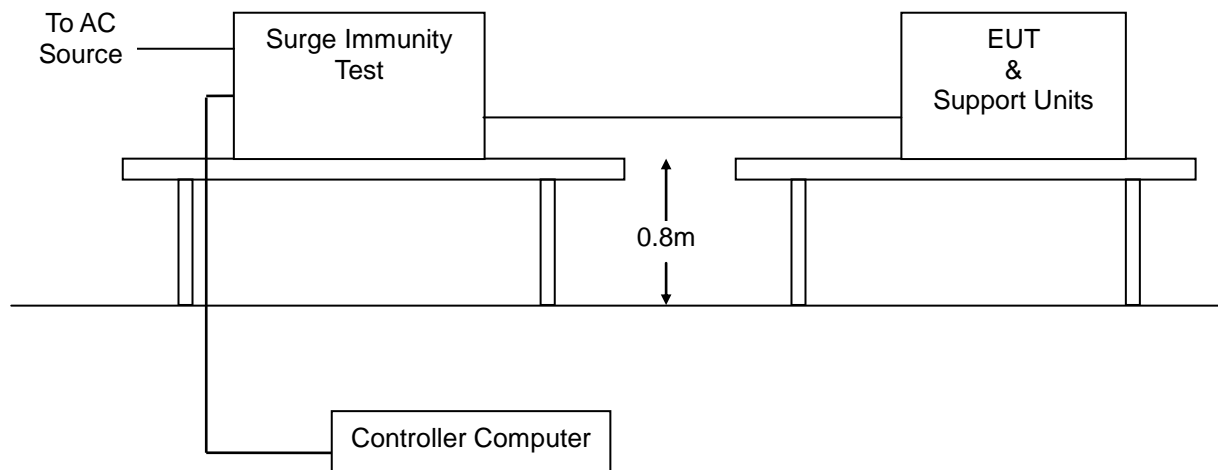

For the actual test configuration, please refer to the related item – Photographs of the Test Configuration.

8.6.5. TEST RESULTS

Temperature:	26°C	Humidity	55% RH
Pressure	996mbar	Test Result	Pass
Test mode	Lighting	Test By	Davis Zhou

Test Point	Polarity	Test Level (kV)	Performance Criterion	Observation	Result
L 1 - L 2	+/-	1	B	Note <input type="checkbox"/> 1 <input checked="" type="checkbox"/> 2	PASS
L1 - PE	--	--	--	Note <input type="checkbox"/> 1 <input type="checkbox"/> 2	N/A
L2 - PE	--	--	--	Note <input type="checkbox"/> 1 <input type="checkbox"/> 2	N/A
R - Ground	--	--	--	Note <input type="checkbox"/> 1 <input type="checkbox"/> 2	N/A
T - Ground	--	--	--	Note <input type="checkbox"/> 1 <input type="checkbox"/> 2	N/A

- NOTE:** 1. There was no change compared with initial operation during the test.
 2. The loss of function of the EUT during the test and it was recovered by itself operation after the test.

8.7. CONDUCTED RADIO FREQUENCY DISTURBANCES (CS)

8.7.1. TEST SPECIFICATION

Basic Standard:	EN 61000-4-6
Frequency Range:	0.15 MHz ~ 80 MHz
Field Strength:	3 V
Modulation:	1kHz Sine Wave, 80%, AM Modulation
Frequency Step:	1 % of preceding frequency value
Coupled cable:	Power Mains, Shielded
Coupling device:	CDN-M3/2 (3 wires)
Performance Criterion:	A

8.7.2. TEST INSTRUMENT

CS Test				
Name of Equipment	Manufacturer	Model	Serial Number	Calibration Due
Signal Generator	Maconi	2022D	119246/003	09/09/2013
Power Amplifier	M2S	A00181-1000	9801-112	09/09/2013
CDN	MEB	M3-8016	003683	09/09/2013

NOTE: 1. The calibration interval of the above test instruments is 12 months and the calibrations are traceable to international system unit (SI).
 2. N.C.R.= No Calibration required

8.7.3. TEST PROCEDURE

The EUT shall be tested within its intended operating and climatic conditions.

The test shall be performed with the test generator connected to each of the coupling and decoupling devices in turn, while the other non-excited RF input ports of the coupling devices are terminated by a 50-ohm load resistor.

The frequency range was swept from 150 kHz to 80 MHz, using the signal level established during the setting process and with a disturbance signal of 80 % amplitude. The signal was modulated with a 1 kHz sine wave, pausing to adjust the RF signal level or the switch coupling devices as necessary. The sweep rate was 1.5×10^{-3} decades/s. Where the frequency range is swept incrementally, the step size was 1 % of preceding frequency value from 150 kHz to 80 MHz.

The dwell time at each frequency was less than the time necessary for the EUT to be exercised, and able to respond. Sensitive frequencies such as clock frequency(ies) and harmonics or frequencies of dominant interest, was analyzed separately.

Attempts were made to fully exercise the EUT during testing, and to fully interrogate all exercise modes selected for susceptibility.

8.7.4. TEST SETUP

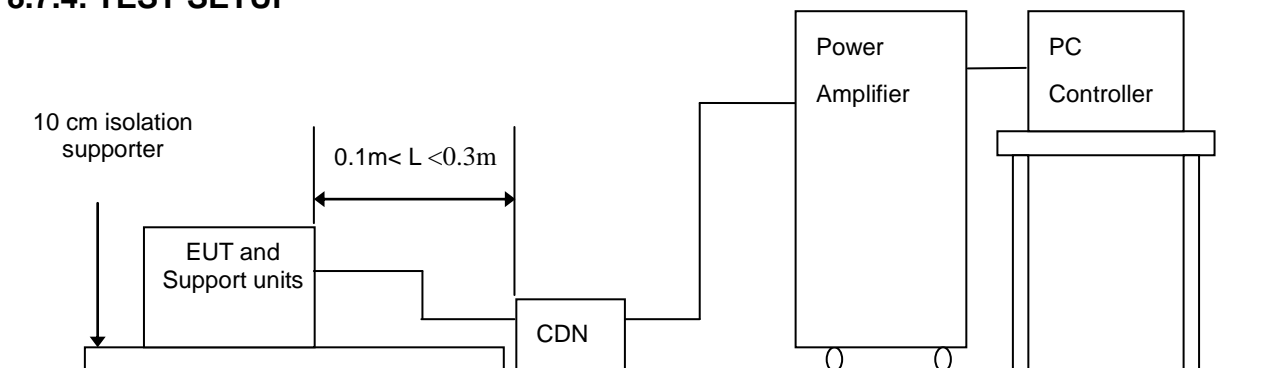

- Note:**
1. The EUT is setup 0.1m above Ground Reference Plane
 2. The CDNs and / or EM clamp used for real test depends on ports and cables configuration of EUT.

For the actual test configuration, please refer to the related item.

NOTE:

TABLE-TOP AND FLOOR-STANDING EQUIPMENT

The equipment to be tested is placed on an insulating support of 0.1 meters height above a ground reference plane. All relevant cables shall be provided with the appropriate coupling and decoupling devices at a distance between 0.1 meters and 0.3 meters from the projected geometry of the EUT on the ground reference plane.

8.7.5. TEST RESULTS

Temperature:	26°C	Humidity	55% RH
Pressure	996mbar	Test Result	Pass
Test mode	Lighting	Test By	Davis Zhou

Frequency Band (MHz)	Field Strength (Vrms)	Injected Position	Injection Method	Performance Criterion	Observation	Result
0.15 ~ 80	3	AC Mains	CDN-M3	A	Note <input checked="" type="checkbox"/> 1 <input type="checkbox"/> 2	3
0.15 ~ 80	3	N/A			Note <input type="checkbox"/> 1 <input type="checkbox"/> 2	N/A

- NOTE:** 1. There was no change compared with initial operation during the test.
 2. The loss of function of the EUT during the test and it was recovered by itself operation after the test.

8.8. POWER FREQUENCY MAGNETIC FIELD

8.8.1. TEST SPECIFICATION

Basic Standard:	EN 61000-4-8
Frequency Range:	50Hz,
Field Strength:	3A/m
Observation Time:	5 minutes
Inductance Coil:	Rectangular type, 1mx1m
Performance Criterion:	A

8.8.2. TEST INSTRUMENT

Immunity Shield Room				
Name of Equipment	Manufacturer	Model	Serial Number	Calibration Due
Power-frequency Magnetic field	SCHAFFNER	CCN 1000-1	72046	11/07/2013
Induction Coil Interface	SCHAFFNER	INA2141	6003	10/15/2013

NOTE: 1. The calibration interval of the above test instruments is 12 months and the calibrations are traceable to international system unit (SI).

2. N.C.R.= No Calibration required

8.8.3. TEST PROCEDURE

- The equipment is configured and connected to satisfy its functional requirements. It shall be placed on the GRP with the interposition of a 0.1m-thick insulating support.
- The equipment cabinets shall be connected to the safety earth directly on the GRP via the earth terminal of the EUT.
- The power supply, input and output circuits shall be connected to the sources of power supply, control and signal.
- The cables supplied or recommended by the equipment manufacturer shall be used. 1 meter of all cables used shall be exposed to the magnetic field.

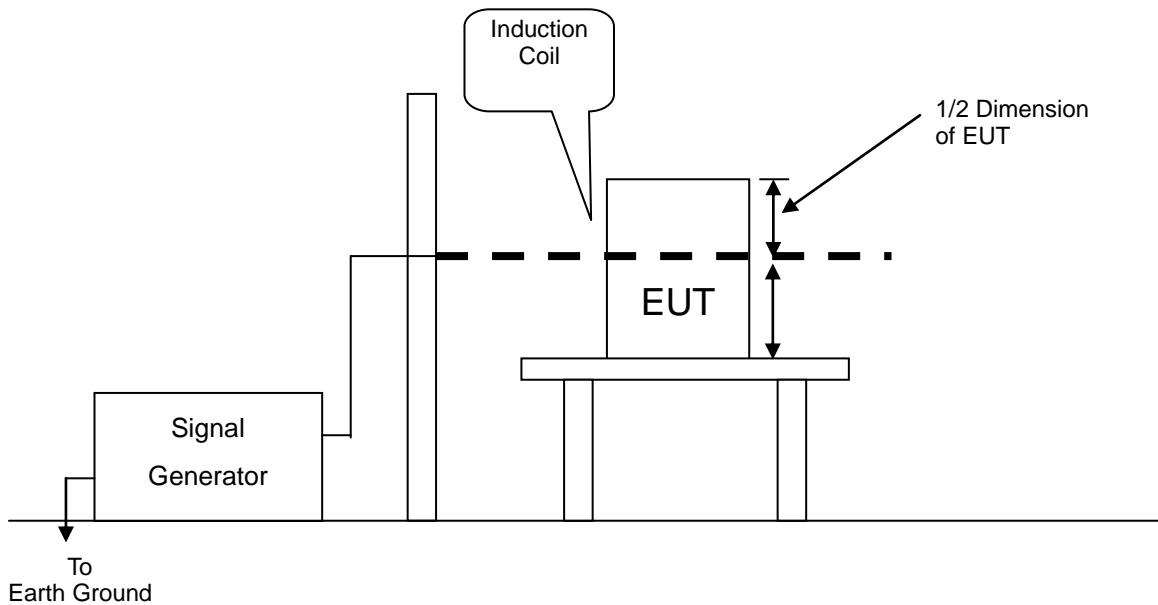

For the actual test configuration, please refer to the related item.

NOTE:

TABLETOP EQUIPMENT

The equipment shall be subjected to the test magnetic field by using the induction coil of standard dimension (1 m x 1 m). The induction coil shall then be rotated by 90 degrees in order to expose the EUT to the test field with different orientations.

FLOOR-STANDING EQUIPMENT

The equipment shall be subjected to the test magnetic field by using induction coils of suitable dimensions. The test shall be repeated by moving and shifting the induction coils, in order to test the whole volume of the EUT for each orthogonal direction. The test shall be repeated with the coil shifted to different positions along the side of the EUT, in steps corresponding to 50 % of the shortest side of the coil. The induction coil shall then be rotated by 90 degrees in order to expose the EUT to the test field with different orientations.

8.8.5. TEST RESULTS

Temperature:	26°C	Humidity	55% RH
Pressure	996mbar	Test Result	Pass
Test mode	Lighting	Test By	Davis Zhou

DIRECTION	Field Strength (A/m)	Performance Criterion	OBSERVATION	RESULTS
X	3	A	Note <input checked="" type="checkbox"/> 1 <input type="checkbox"/> 2	PASS
Y	3	A	Note <input checked="" type="checkbox"/> 1 <input type="checkbox"/> 2	PASS
Z	3	A	Note <input checked="" type="checkbox"/> 1 <input type="checkbox"/> 2	PASS

NOTE: 1. There was no change compared with initial operation during the test.
2. The loss of function of the EUT during the test and it was recovered by itself operation after the test.

8.9. VOLTAGE DIPS & VOLTAGE INTERRUPTIONS

8.9.1. TEST SPECIFICATION

Basic Standard:	EN 61000-4-11
Test Duration Time:	Minimum three test events in sequence
Interval Between Event:	Minimum 10 seconds
Phase Angle:	0 / 45 / 90 / 135 / 180 / 225 / 270 / 315 / 360
Test Cycle:	3 times
Performance Criterion:	B,C

8.9.2. TEST INSTRUMENT

Immunity shielded room				
Name of Equipment	Manufacturer	Model	Serial Number	Calibration Due
EMC PARTNER TRANSIENT 2000	EMC PARTNER	TRA2000	881	07/11/2013

NOTE: 1. The calibration interval of the above test instruments is 12 months and the calibrations are traceable to international system unit (SI).
2. N.C.R.= No Calibration required

8.9.3. TEST PROCEDURE

1. The EUT and support units were located on a wooden table, 0.8 m away from ground floor.
2. Setting the parameter of tests and then perform the test software of test simulator.
3. Conditions changes to occur at 0 degree crossover point of the voltage waveform.
4. Recording the test result in test record form.

For the actual test configuration, please refer to the related item – Photographs of the Test Configuration.

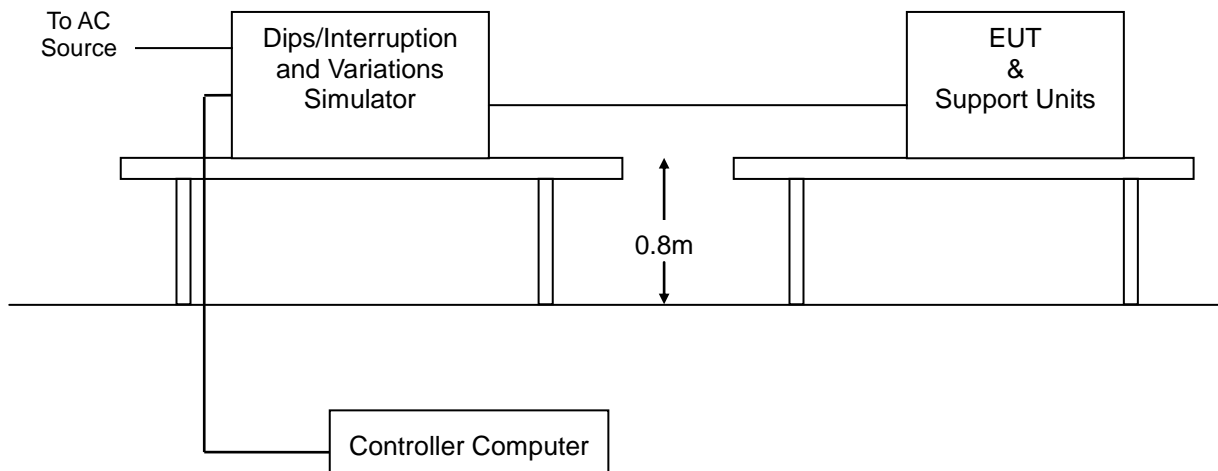
8.9.5. TEST RESULTS

Temperature:	26°C	Humidity	55% RH
Pressure	996mbar	Test Result	Pass
Test mode	Lighting	Test By	Davis Zhou

Test Power: 230Vac, 50Hz				
Voltage (% Reduction)	Duration (Period)	Performance Criterion	Observation	Test Result
0	0.5	<input type="checkbox"/> A <input checked="" type="checkbox"/> B <input type="checkbox"/> C	Note <input type="checkbox"/> 1 <input checked="" type="checkbox"/> 2 <input type="checkbox"/> 3	PASS
70	10	<input type="checkbox"/> A <input type="checkbox"/> B <input checked="" type="checkbox"/> C	Note <input type="checkbox"/> 1 <input type="checkbox"/> 2 <input checked="" type="checkbox"/> 3	PASS

NOTE: 1. There was no change compared with initial operation during and after the test.
 No unintentional response was found during the test.
 2. The function stopped during the test, but can be recoverable by itself operation after the test.
 3. The function stopped during the test, but can be recoverable manually after the test.

9 PHOTOGRAPHS OF EUT

Appearance photograph of EUT





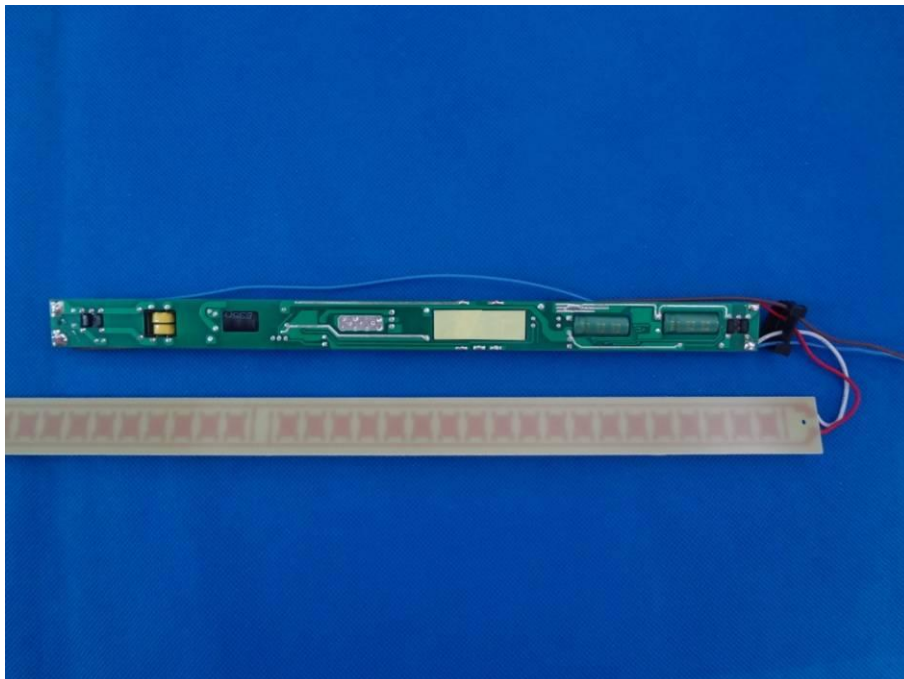
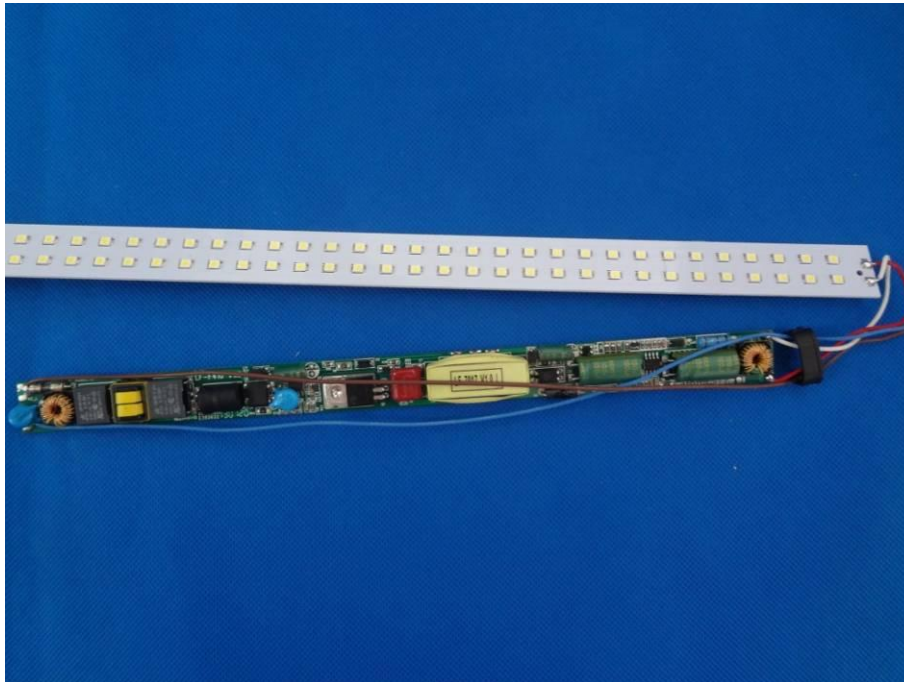

10 Photo of test scene





*****END OF REPORT*****