



Vintage

PATIO COMFORT

OUTDOOR PATIO HEATER

Vintage Series Model PC-02 CAB

ASSEMBLY INSTRUCTIONS CARE, USE, AND SAFETY MANUAL

FOR YOUR SAFETY!

Do not store or use gasoline or other flammable vapors or liquids in the vicinity of this or any other open flame appliance.

WARNING: For Outdoor Use Only

IMPORTANT!

Please read these assembly instructions carefully before attempting to assemble, use, or service this product. Please keep this manual for your future reference. If you have any questions, please feel free to call us at 949-474-3070 Monday through Friday 7AM to 4PM Pacific Time.

General Hazard Warning:

Improper installation, adjustment, alteration, service or maintenance of this product can cause injury or property damage. Please read the installation, operating, and maintenance instructions thoroughly before installing or servicing this appliance.

Please read all operating instructions before using and operating this appliance.

Always follow the correct lighting and usage procedures. Please handle metal parts with care to avoid injury. Please follow all steps as outlined. Never allow children to use this product!



Please Note:

This product is for outdoor use only!
This product meets or exceeds CSA Requirement for Gas Fired Infrared Patio Heaters No. 5.90 – 2000. Canada 1-2.23 M82. Please use a Type 1 QCC ACME Tank Only with Overfill Protection Device (OPD). Maximum inlet pressure 11"

Manual Revised 10/12/2007

Caution: Hot while in operation. Do not touch. Keep children, clothing, furniture, gasoline, and other liquids having flammable vapors away.



Please pay particular attention to section with this symbol, it notes a very important safety issue:

1. The installation of this appliance must conform with local codes or, in the absence of local codes, with the National Fuel Gas Code ANSI Z223.1-1988.
2. There must be adequate clearance around all air openings into the combustion chamber, clearances from combustible materials, and accessibility and for combustion and ventilating air supply. See page 9 for specific clearances from combustibles.
3. The minimum inlet gas supply pressure must not exceed 11" W.C. Use only the hose, regulator, and tank adapter that is supplied with the product.
4. The maximum inlet supply pressure is 11.0 "W.C.
5. Test all fittings and connections with a soapy solution prior to use. Never use an open flame or open flame device to test for leaks.
6. Certain items or materials when stored under the heater or too close to the heater head will be subject to radiant heat and these items could be damaged.
7. Please review carefully and follow all assembly instructions as shown from pages 3-8. If you do not understand any of these instructions please call your selling dealer or call us directly at 949-474-3070.
8. Please carefully inspect the rubber hose included with the unit before each use. Be sure there are no visible cracks, damage, abrasion, or other signs of visible wear. If the hose appears to have any problem whatsoever it should be replaced with a genuine Patio Comfort replacement part.
9. In the event your unit uses an approved 12 foot hose please be sure that it is placed in a manner when it cannot be damaged or positioned in a way that someone might trip over it.
10. Please follow the lighting and shutdown instructions on page 9. to insure safe use.



Please note the following very important safety precautions:

Children and adults should be alerted to the hazards of high surface temperatures of the main burner and reflector and should stay away from these areas.

Children should be carefully supervised when near the heater. This heater is not a toy and children should not be allowed to push, climb on, or swing on the heater. This could cause serious injury, property damage, or death.

Clothing or other flammable materials should not be hung from the heater or placed near the heater while in operation.



The heater should be visually inspected before each use and at least annually by a qualified service person. Certain weather conditions such as being near the ocean, dusty areas, areas with high humidity, areas with high wind conditions, and heavy use, may require more frequent cleaning or maintenance. When in doubt call a qualified service person. It is imperative that the control compartment, burner system, and circulating air passages of the heater be kept clean.

Any heater part or component removed for cleaning or maintenance must be properly re-installed before using the heater.

Some basic maintenance instructions:

Be sure to keep the area where the appliance is being used free from combustible materials, gasoline, and other flammable materials.

Please be sure there are no obstructions near the heater head.

Please be sure there is no debris or other obstructions near the cylindrical propane cylinder enclosure.

The appliance is operating properly when there is a nice cherry red glow (seen better at night) coming from the emitter grid starting two to three inches from the bottom of the emitter grid. Wind gusts will affect the glow and flame pattern. The heater should not be operated in windy conditions. If you can protect the heater from wind gusts it will operate far more efficiently. Operating the unit in severe wind or dusty conditions will affect the burning characteristics, may create soot on the emitter grid and burner, and possibly clog the pilot or main burner orifices.

The heater support and base may be cleaned with basic soap and water and mild household cleaning products, car wax, or commercially available stainless steel cleaners.

Never attempt to clear the emitter grid radiant with any cleaning solutions. Never spray this area with water or other liquids as it will damage the radiant, burner, valve, and ignition system. These parts are constructed of commercial quality stainless steel and brass and require no maintenance.

Occasionally, you can gently brush the emitter grid with a small brush to remove excess soot that may have accumulated on the emitter. If the emitter grid shows sooting you may have to remove the emitter grid and clean the burner head as well.

See page 12 of the manual for added information. Some basic information on propane (LP) Gas (More complete Guide is on Page 16 and is worth your time to review©

1. Your Patio Comfort heater has been carefully designed to provide many years of service. Only use an ACME Type 1 equipped Five Gallon Propane Cylinder with approved overfill protection device or "OPD." Please do not try to modify or convert your heater to accept another fuel type accept any other type size cylinder, hose, or regulator.
2. Only cylinders that are constructed to meet the U.S. Department of Transportation (DOT) requirements should be used with the heater.
3. It is absolutely imperative that this heater only be used OUTDOORS and in a well-ventilated space and shall not be used in a building, garage, motor vehicle, boat, tent, manufactured structure or other enclosed areas. This is an unvented heating product and creates by products of combustion that can cause injury and possibly death.
4. The propane cylinder should be connected and disconnected with the main fuel valve in the off position. This can be achieved by turning the triangular handle on top of the cylinder in a clock-wise direction. The hand wheel must be tightened securely for the gas to flow from the cylinder. You do not need any tools to make the proper connection from the LP adapter to the tank. Do not over-tighten the hand wheel or you may damage it. For complete instructions in this are a please refer to manual pages 8-9.
5. The cylinder should be disconnected from the heater at the tank when not in use. Propane cylinders can only be stored outdoors. For complete storage instructions refer to page 11 of this manual. Never store a cylinder in any enclosed area.
6. Only the hose, regulator, and LP Adapter designed for an OPD cylinder supplied with appliance can be used. If you require a replacement these can be easily obtained from your Authorized Patio Comfort dealer. An improper hose and regulator may compromise the performance and safety of your heater.

The preceding pages attempt to highlight only the most important safety aspects and guidelines for using your Patio Comfort heater. We have made every effort to thoroughly address all safety, assembly, lighting, propane storage, and use issues for this product in the manual to follow. We strongly encourage that you read and understand the materials contained in the manual before using your heater. If you have any questions whatsoever regarding the safe assembly or use of your heater please call your Patio Comfort Dealer or Authorized Distributor or call us directly at 949-474-3070

Thank you very much for purchasing a *Patio Comfort* Patio heater. This manual contains very important information detailing the proper assembly, operation, and maintenance of this product. This product has been designed with the latest in safety technology but it is important to remember that this is a heating appliance and some of the surfaces are extremely hot to the touch and can cause bodily injury. Important safety information is presented throughout this manual for your safety and that of your family. We have designed this product to provide you with many years of outdoor comfort when operated and maintained properly.

Table of Contents

- Basic Safety and Operational Data..... 1-4**
- Table Of Contents6**
- Technical Data, Function of Heater, Assembly Tips7**
- Parts Diagram and Part Descriptions (Heater Head)8**
- Parts Diagram (Base and Support)9**
- Tools Required, Fastener Identification & Assembly Instructions 10-11**
- Preparation for Use and Cylinder Information..... 12-13**
- Placement of the Heater & Clearances Required 13**
- Proper Lighting Instructions 14**
- Relighting and Shut Down Instructions 15**
- Storing Your Heater & Insect Warning 15**
- Cleaning and Maintenance 16**
- Trouble Shooting Guide 17**
- Detailed Warning and Safety Points..... 18-19**
- Some Important Safety Tips on Propane and the safe use of propane20**
- Warranty & Service Information 20-22**
- Warranty Registration Form.....23**

Technical Data

Fuel: LPG (Propane) Only

Heating: Each *Patio Comfort* heater will cast a 10-12 foot circle of sun like radiant heat. Heat output will vary based on "wind chill" factor, outside air temperatures, altitude, prevailing wind conditions, and location of heater.

Gas Cylinder: A Type 1 "ACME" QCC with Overfill Protection Device (OPD) Cylinder is required but not included. All new cylinders are empty and should be filled by an authorized fueling station or cylinder exchange facility.

Pressure: The unit is equipped with an LPG Regulator Preset to 11.0 Inches Water Column. This specially designed regulator must be used with this appliance. Maximum supply inlet pressure 100 psi. Minimum inlet supply pressure 5 psi.

Fuel Consumption: 40,000 BTU Input /Hour Cylinder will operate unit for approximately 9 - 10 hours on "ON" setting. Longer burn times can be achieved by reducing fuel input at heater valve control knob.

Orifice Size: 1.90 mm

Weight: 95 pounds or 43 Kilograms not including cylinder and fuel. Tank plus fuel weighs 40 lbs.

Overall Height: 95 inches 233 cm

Reflector Diameter: 34 inches or 86 cm

Ignition System: Push Button Piezo with Pilot Flame

Fasteners: 304 Series Commercial Grade Stainless Steel

Materials: Reflector: Anodized Aluminum – Major Components: Series 304 & 403 Stainless Steel.

Cast aluminum base and post. Heavy-Duty Cast iron base. Paint is mechanically bonded

Polyurethane powder coating. Emitter 304 SS

Other features: 100% Safety Shut Off Valve

No Electrical Connections Required

Constant Pilot

Completely Self- Contained

Safety Latch on French doors.

Function of Heater

Infrared heaters utilize virtually 100% of the fuel/energy they consume to produce clean draft-free warmth. Infrared heaters do not waste precious energy by trying to heat the air. Infrared heat works like the radiant rays of the sun and will directly heat objects near them such as people, tables, chairs who in turn will absorb the heat and reflect it. The push button Piezo ignition system is

used to light the pilot flame first. After the thermocouple device allows gas to flow to the main burner head you may then safely engage the main burner system by turning valve control knob to "ON" Setting.

After the main burner is lit the burner will radiate heat in a 360-degree circle. The circle of warmth will vary dependent on outdoor temperatures, wind chill factor, area protection, and other variables. The average heating area is approximately a 10-foot ring of warmth. The reflector will return upwardly radiated heat downwards. On the initial lighting please allow heater to burn a few minutes to burn off machining oils used in the production of the heater.

Please note: *Upon first using the heater, not using the heater for an extended period, or after attaching a newly filled cylinder it might be necessary to depress the control knob at the "PILOT" setting up to two to three minutes to purge the air in the fuel lines before the PILOT flame will ignite. Please be patient, this is all part of the safety system that has been designed for your protection.*

Assembly Tips

For your convenience and safety the *Patio Comfort* outdoor patio heater has been almost completely assembled. The burner head and valve assembly have been fire tested for added safety.

Assemble all nuts and bolts loosely at first. Tighten all connections after the completion of the assembly process. This eases your work and increases the overall stability of the appliance. Before using the heater be sure to check all connections with a solution of soap and water. More on this later in the instructions. **Never use a flame to check for leaks!**

When starting the assembly process please take all of the parts out of the box and check if anything is missing. Please check parts with the following parts breakdown. Even though we exercise extreme quality control procedures occasionally we will have a missing part or a part may have been damaged in transit. **If anything is missing, please contact your *Patio Comfort* dealer or call us directly at 949-474-3070. We will immediately help you.** The same holds true on any questions you might have on assembly or operation. When in doubt please ask, we're at your service.

Patio Comfort VINTAGE Outdoor Patio Heater Model PC-02 CAB

Parts Diagram and Repair Parts

KEY	PART #	Description	Qty
1#	1001 03	M8 Wing nut	3
1	1001	M8 Hex nut	3
2	1002	8mm Flat Washer SS	6
3	1003	Reflector	1
4	1004	8mm Lock washer SS	3
5#	1005#	M8x20mm Hex Bolt	3
5	1005	M8x20mm Hex Bolt in Bronze	4
6	1006	Emitter Grid	1
7	1007	Main Burner Assembly	1
8	1008	M4x8mm ST shield screw	2
9	1009	M4x6mm screw SS	2
10	1010 07	Base Fitting for Burner	1
11	1011	M5x10mm ST screw SS	4
12	1012	Pan Assembly SS	1
13	1013	Perforated Body	1
14	1014	Pilot Shield	1
15	1015	Electrode	1
16	1016	Pilot Assembly	1
17	1017	Wire Insulation	1
18	1018	Thermocouple	1
19	1019	Pilot Assembly	1
20	1020-07	Orifice for Main Burner	1
21	1021	Pilot Orifice	1
22	1022	Tubing for Main Burner	1
23	1023	Thermoelectric Valve	1
24	1024	Extension fitting at valve base	1
25	1025	Bracket for valve mounting	1
26	1026	Bracket for Extension fitting	1
27	75027	Base Assy. for Heater Head	1
28#	1028#	# 6mm Flat Washer SS	12
28	1028	6mm Flat Washer in Bronze	4
29	75029	Hinge for door panels	4
30	1030	Faceplate with Lighting Instructions	1
31	1031	Knob	1
32	1032	Specific Nuts for Thermocouple	2
33	1033	Piezo Igniter	1
34	1034	M6x12mm PH Screw in Bronze	12
35#	1035#	M5x8mm PH Screw SS	9
35	1035	M5x8mm PH Screw in Bronze	6
36	75036	Post Bronze	1
37	75037	Latch Assembly Bronze	1
38	75038	Socket Assembly Bronze	1
39	75039	Dec Cover Top Bronze	1
40	75040	Stationary Dec Panel Bronze	2

Patio Comfort VINTAGE Outdoor Patio Heater Model PC-02 CAB

Parts Diagram and Repair Parts

KEY	PART NUMBER	DESCRIPTION	QTY.
41	75041	Right Front Door Panel Bronze	1
42	75042	Left Front Door Panel Bronze	1
43	75043	L Bracket Bronze	3
44	1044	M6x12mm Hex Bolt	12
45	75046	Fuel Tube Feedline	1
46	1114/1115	LP Hose and Regulator Assembly	1
47	75048	Base Bronze	1
48	75049	Rubber Molding for Base	1

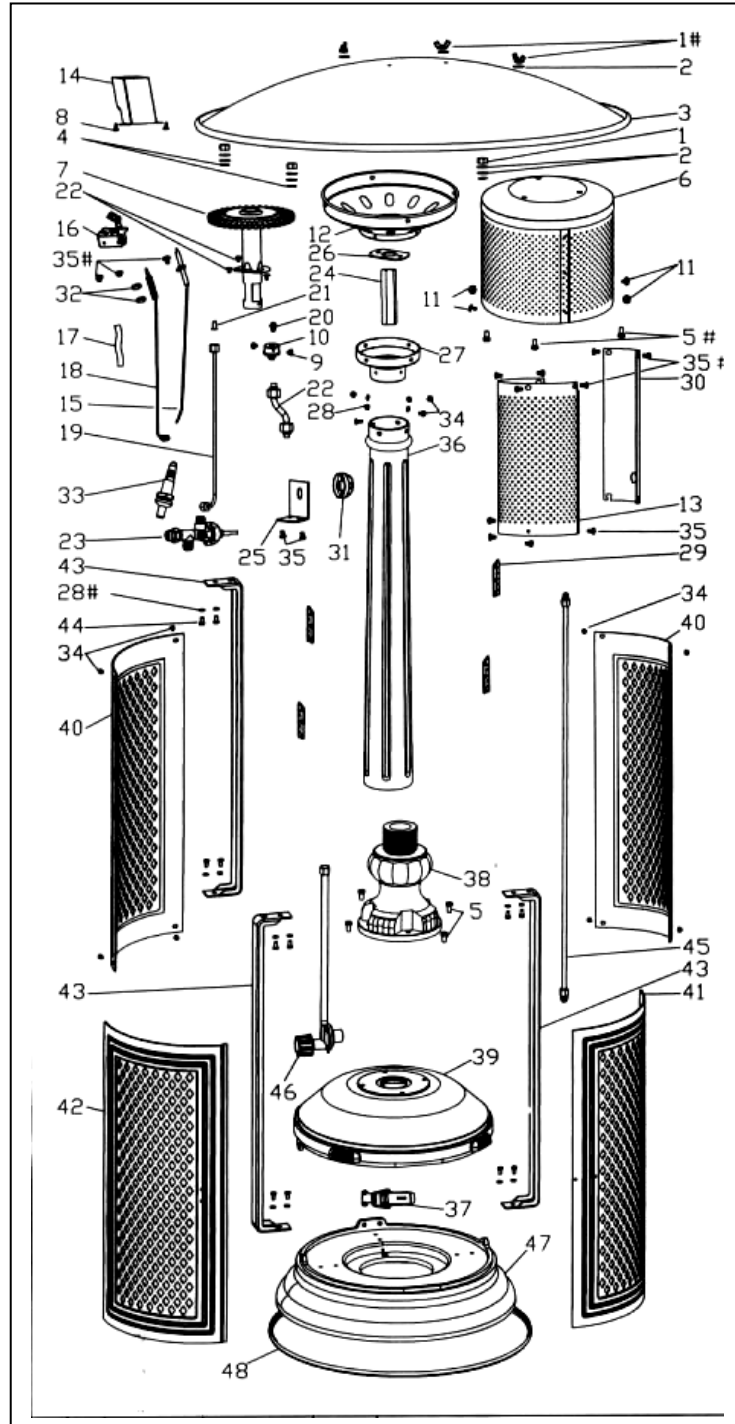

You will need the following tools to assemble the heater:

14MM or 9/16 Socket or open-end wrench
Standard Phillips Head Screw Driver #2 x 4

Adjustable Open End Wrenches-Minimum 1 ½”
Adjustable Crescent Wrench or Socket Driver
Soapy Water Solution for leak testing

Do Not Use any Teflon tape or other sealants when connecting heater head to feed line or hose to feed line. These are “brass to brass” connections and will seal without the need for Teflon tape or pipe dope.

Fastener Identification

Heater

3 - Wing Nuts for reflector

4 14 MM Lock Washers (Socket to base)

4 – Flat Washers 6 mm dia. (Post to head)

4 14 MM Bolts (Socket to Base)

4 8 MM SS Philips Screws (Post to Head)

PLEASE NOTE: The proper assembly of this heater requires basic mechanical skills. Proper assembly is the responsibility of the installer. A qualified gas appliance technician should do any and all repairs or service. If you have any questions please feel free to contact us.

Assembly Instructions



HEAD PACKED IN BASE ASSEMBLY

Step 1 The majority of your *Patio Comfort*

Vintage Outdoor Patio Heater product is already assembled, tested, and pre-fired for your safety and convenience. We have shipped the heater head enclosed into the pre-assembled lower base to protect the heater head in shipment and to simplify assembly.

Step 2 Packed in the top of the heater box is a large black rubber gasket that is intended to be a barrier between the cast iron base and your patio. It is most easily attached with two people by simply having one person tip the base while the other pushes it over the bottom ledge. **IT IS IMPERATIVE THAT THIS GASKET IS ATTACHED AS A BARRIER TO PROTECT YOUR PATIO**



Step 3 Carefully insert the 4 of the 14 mm bolts and lock-washers through the socket assembly and into the four

holes provided at the top of the cast cylinder enclosure. Please carefully start and insert all four hex head bolts by hand and be careful not to cross-thread. After the bolts have been aligned and started smoothly evenly tighten all bolts with a 14mm open-ended wrench or socket. Do not over-tighten.



SOCKET ATTACHED TO TOP OF TANK ENCLOSURE



ALUMINUM POST TO SOCKET

Step 4 Carefully thread the cast aluminum post assembly onto the socket assembly that you have just attached to the cylinder enclosure, Start the threading process carefully and be sure not to cross-thread. Tighten securely until the post touches the top of the tank enclosure. If you have

purchased the optional utility table it needs to be placed on top of the threaded socket before securing the post.



FEEDLINE TO HEAD

Look through feed line to be certain that there are no pieces of packaging, paper, or other obstructions in the feed line. Remove any obstructions.

Either end of the feed line can be screwed into the heater head. Now insert the feed line with 3/8" flared fitting into the base of the heater head. Do not use any Teflon tape or other sealant on this or any other brass-to-brass connection. Brass to brass will self-seal. Securely tighten the connection using two wrenches in a clock-wise direction. Do not over-tighten.



HEAD WITH FEED LINE TO POST

Step 6 Tip heater at an angle and carefully insert the feed line down through the post until it goes through a access hole in the top of the tank enclosure. Do not secure head to the post at this time. We will need to do a simple leak test first.

The 3/8" feed line flared fitting will be visible inside the top of the cylinder enclosure. Now attach the hose and regulator to the feed line and securely tighten fittings with a wrench in a clockwise direction. No sealant is required.

Step 5 Remove the plastic protective caps from the ends of the 3/8" flare fittings at each end of the solid feed line tube. Any other post or feed line packaging material must also be removed.



LP HOSE/REG TO FEEDLINE

Step 7



Now we will do a very important safety check: **This check should be done outdoors and not near an open flame.**

To properly perform the safety check be sure the heater head control is in the "OFF" position. Insert your **filled propane cylinder** into the enclosure, attach the hose and regulator assembly to the tank and turn on the flow of fuel from the tank to the heater.

Now lift the heater head slightly from the post, and spray a soapy solution at the feed line fitting that is going into the base of the heater head. If you see bubbles the connection at the feed line to the heater head it is not adequately gas tight. Immediately turn off the flow of fuel at the tank. Retighten. Also spray the soapy solution where the rubber hose connects to the bottom of the feed line. If you see bubbles you must re-tighten. Re-check connection after tightening. Please turn off the valve, disconnect and remove tank for the balance of assembly and then re-install the tank for use.

PROCEED TO SECURE HEATER HEAD TO POST ONLY AFTER CERTAIN OF NO GAS LEAKS



PHILIPS HEAD SCREWS SECURING HEAD TO ALUMINUM POST

Step 8 Carefully and loosely insert all four Phillips head screws and flat washers into the holes in the top of the post and then aligning them so they go into the heater head base. Check for proper alignment before tightening. Tighten all four screws securely applying equal force to all four screws as you tighten them. **Do not over-tighten.**

Step 9 Attach rubber protective ring to bottom of base.



WING NUTS TO SECURE REFLECTOR

Step 10- We're almost finished! Tip the heater slightly (this may require the help of another person) and place the reflector onto the top of the heater head aligning the three holes in the reflector with the three bolts extending from the top of the heater head. Place a 8 mm flat washer on each bolt and secure reflector by putting on the three wing nuts. Tighten securely but do not over tighten. It's just that easy! Re-install the propane cylinder. Your heater is now ready to be test fired. Please read our manual thoroughly and when comfortable with the product and its features go to the "Lighting Instructions Section" and safely light your heater. We know you'll enjoy this top quality outdoor heater for many years to come!

FINAL STEP Be certain that all screws and all connections are fully tightened.

PLEASE NOTE: If you have a new style propane cylinder that senses a leak in the fuel delivery system it may automatically reduce the flow of fuel to the burner head at the tank. You may hear a slight "click" this is the sound of the safety device activating. Your tank is doing exactly what it's designed to do and that's to reduce the flow of gas if it senses a leak in the system. This is done for

your protection. Again, check for leaks with a soapy solution if this occurs. **If your tank safety system activates turn cylinder valve off and wait five minutes for the safety system to reset.**

NOTE: If you do not properly tighten and engage the hand wheel and connection device at the regulator assembly it will NOT allow gas to flow from the tank to the appliance. Be sure your have a 100% safety connection. Do Not use tools to tighten regulator hand wheel to tank valve.

Preparation for use

You will need to purchase a 20-pound TYPE I OCC/ACME propane cylinder equipped with an Overfill Protection Device. Your *Patio Comfort* dealer or distributor can provide you with this safety cylinder. We highly recommend you purchase a new 20 lb. OPD cylinder manufactured by either Worthington Cylinder or Manchester Tank Company. Both are U.S. producers of highly quality propane cylinders.

Please do not try to use any other propane cylinders with this appliance. Please do not attempt to modify our hose assembly, regulator, valve, ignition system or other components. These high quality components have been integrated in your heater to provide you with maximum safety, performance, and reliability.

Installation of Cylinder

After purchasing a filled propane cylinder you will be ready to install it into your Patio Comfort heating appliance.

a. Position the propane cylinder next to your appliance keeping in mind that the cylinder must be kept away from any heat or open flame and must be stored outside. Never lay a cylinder on its side for use or storage.

b. When you are ready to use your heater attach the regulator to the cylinder valve.

c.

Note: Before lighting your heater please review thoroughly all of our safety warnings and lighting instructions. Always check the rubber hose to be

sure there are no cracks in the hose, cuts, or other abrasions, which might cause a fuel leak.

If the hose or regulator assembly is found to be faulty in any way DO NOT USE the appliance. Call your authorized **Patio Comfort** dealer and only use genuine **Patio Comfort** replacement parts. Using improper parts may damage the product or cause physical or property damage.

Changing Your Cylinder

These OPD Cylinders are equipped with a safety feature that will not allow the flow of fuel unless the proper gastight connection has been made.

Placement of the Heater

Your **Patio Comfort** outdoor patio heater is designed for use as temporary comfort heating for your outdoor patio, outdoor decks, outdoor spa areas, pool areas, and other outdoor areas with plenty of fresh air.

The heater is NOT designed, approved, or intended for indoor use or enclosed area use such as a garage, commercial building, tents, ice fishing tents, prefabricated buildings or enclosures or other enclosed areas.

The heater is also not designed for use on moving objects or vehicles such as houseboats, yachts, travel trailers, boats, or other moving devices or vehicles. **DO NOT MOVE HEATER WITH CYLINDER INSTALLED.**

The minimum clearances from combustibles must be maintained at all times. We recommend the heater be no closer than 24 inches from any combustible vertical or horizontal wall or have any combustible material within 24 inches of the top of the reflector. **We strongly recommend the heater shall have a clear opening from the top of the reflector.**



To change the cylinder, open the safety latch securing the access doors. Open the French doors in the base then turn off the gas supply at the top of the tank in a clock-wise direction and unscrew the large black knob attached to the propane regulator. When transporting your cylinder be sure that it is always in an upright position. Please read all safety tips on propane on page 16. Your OPD cylinder will also have helpful hints on the transportation and storage of propane. Propane is an extremely safe and tested fuel but it must be handled with care and respect.

These minimum clearances from combustible materials must be maintained anytime the heater is in operation.



The heater must always be used on firm, level, and stable ground. Never move the heater while it is in operation. **WARNING:** Never operate heater in an explosive atmosphere and be sure to keep unit away from where gasoline or other flammable liquids or vapors are stored or used.

Lighting Instructions

For your own safety, please be sure to read and thoroughly understand pages 2, 3 and 4 regarding the proper handling of propane and other safety precautions and warnings.

Before turning on the fuel supply at the tank visually inspect the hose assembly for evidence of excessive abrasion, cuts, cracking, or unusual wear and tear. If the hose leaks it must be replaced prior to using the heater. Only use replacement hoses and other parts as specified by ***Patio Comfort***.

Before Lighting

If attempting to relight a hot heater always wait at least five minutes. The main heater components such as the emitter grid, gas hook up, and pilot assembly should be checked at least every two years by a qualified service technician or if you feel the appliance is not working properly.

To Light Heater

- 1) Open the access doors and be sure that the LP regulator is properly engaged into the propane tank.
- 2) Be sure the control knob on the heater head is in the "OFF" position.
- 3) Turn the tank valve in a counter-clockwise direction to open. If the regulator assembly is not properly engaged into the tank the flow of gas will be interrupted by the safety shut off device. No gas will go to the heater.
- 4) Gently depress the control knob on the control panel and rotate it counter clockwise to the "PILOT" position.
- 5) *This is very important!* Gently depress the control knob and hold the control knob to begin the flow of gas to the burner pilot assembly. Depress the control knob in the "PILOT" position for up to **2 minutes on new installations or newly filled tanks.** This is how long it might take for the air to be purged from the fuel delivery system. It will take less than 10 seconds for regular relighting. Do NOT continually press on the igniter while you are purging the line. This will only cause premature wear and tear on the ignition. Occasionally depress the igniter you will hear when the pilot light goes on. You can also see the pilot light through the pilot access port that has a small rectangular cover at the base of the heater head. This is essentially the same safety system that you have on your water heater.
- 6) Once the pilot is lit, continue to depress the control valve for about 20 seconds or until the pilot flame remains lit after the control knob is released.
- 7) The burner may now be turned on to the full "ON" position for maximum heat output. The heater is designed to operate in the full "ON" position for maximum heat and clean burning performance. Or it may be turned back slightly to reduce heat output and fuel consumption. If you turn the control knob all the way back to the "PILOT" position the main burner will go off and the pilot flame will remain lit, you can then re-ignite the main burner directly from the "PILOT" position. A little smoke is to be expected on the first lighting. This is machining oils being burned off.

If you turn the heater off and then have to re-light

- 1) Turn control knob to the "OFF" position.
- 2) Wait at least FIVE minutes before attempting to relight heater. The safety system built into the heater will not allow you to immediately re-light the heater directly from the "OFF" position. Please do not try to defeat this safety system.
- 3) Repeat starting with STEP #6. You should not have to wait more than few seconds to re-light the "PILOT" light and then ignite the main burner.

To Turn Off or Shut Down Heater

- 1) Turn the control knob in a clock-wise direction to the "OFF" position. You may hear a slight popping sound when the main burner shuts down. This is normal.
- 2) Lift the decorative cover up the post and turn the valve on the top of the propane tank in a clock-wise direction to turn it off.

When your heater is not in use DO NOT store your propane cylinder indoors.

Storing your Heater and Insect Warning

Be sure control knob is in the "OFF" position and the cylinder valve is CLOSED.

When storing the heater please disconnect the tank from the heater at the regulator and LP cylinder. The tank should be stored outdoors in a well-ventilated area to be in compliance with ANSI Standard and NFPA National Fuel Protection Agency Code 58-1986. Store your heater in an upright position in an area sheltered from inclement weather such as rain, snow, sleet, hail, dust storms, and other blowing debris.

Patio Comfort makes a cover available to protect the burner head. We strongly recommend using our cover when your heater is in storage or not in use. The Item number for the cover is "PCC-1" This cover is available from your **Patio Comfort** retailer or distributor. The cover will help protect the heater head from moisture as well as insects. **CAUTION: Be sure heater is cool to the touch before using the cover.**

Spider and Insect Warning

Spiders and other insects are attracted to the smell of natural gas and propane. This is the case for outdoor heaters, gas grills, gaslights and torches, pool heaters, and other outdoor gas burning products. The webs and obstructions created by these insects can causes conditions that may damage the appliance or render it unsafe for proper use. You should inspect the burner at least once a year or immediately if any of the following conditions are present when operating the heater:

1. The odor of gas in conjunction with extreme yellow tipping of the burner flame.
2. The emitter grid does not glow evenly or reach proper operating temperatures.
3. The burner makes a popping or roaring noise.

If you feel uncomfortable working on the heater please contact your servicing dealer or distributor for the name and number of a qualified service technician.

Cleaning & Maintenance

Your heater has been produced from highly weather resistant materials and only requires minimum cleaning and maintenance. Cleaning must be performed when the heater is cold. Your patio heater will last longer if it is cleaned and maintained properly. It is very important that the air required for the combustion process is not blocked going to the burner. Orifices, burner venturis, vents, and other openings must be kept free of dirt and spider webs.

Stainless steel does not "rust," however varying atmospheric conditions; areas with acid rain, beach and ocean areas with heavy misty conditions may leave brown deposits on the heater. This is to be expected of any stainless steel product used outdoors. We recommend washing the outer stainless steel components such as the post and decorative cover and perforated material around the lighting instructions with a mild detergent solution and immediately wiping it clean with a dry soft cloth. The stainless steel can be expected to darken and discolor around the heater head and pan as it sustains extreme temperatures. This is normal and to be expected with any outdoor gas heating or cooking appliance.

Never use a cleaning agent that is flammable or corrosive. There are several excellent stainless steel cleaners available through your local dealer for our stainless steel models. If you do not find a suitable local source call us directly and we can provide you with an excellent cleaner. **Never spray any cleaning product on the emitter grid or burner area.**

If you purchased a powder-coated model, treat it just like you would any other piece of fine outdoor patio furniture. Wash all painted parts of the heater with a soapy solution and protect it with a coat of automobile car wax a couple of times per year or as required dependent upon your local weather and climate conditions.

If you need to touch up a painted heater only paint the post and base portions. Never paint the emitter grid, lighting instructions, valve or control knob area, or the LP cylinder. The burner ports must also be kept clear so that the burner burns evenly and the flow of gas is not restricted. If the heater is not performing adequately it will be necessary to check the burner and burner venturi.

In a salt air or ocean environment, corrosion and rust occurs at a far greater rate than in non-ocean areas. You will need to more frequently check for corrosion and replace parts as required. The best protection for the critical heater head is a **Patio Comfort** cover that has been specifically designed for your heater. The cover can be purchased at your **Patio Comfort** dealer. A stainless steel protective cleaner such as PGS Stainless Steel Cleaner will help protect the finish of all stainless steel components.

TROUBLE SHOOTING GUIDE

If you are having this problem:	If this condition exists:	You will need to do the following:
The pilot light won't light	Cylinder valve is closed Air in gas lines Reg. not fully engaged into tank Low gas pressure with cylinder valve open Igniter is not sparking	Open valve at cylinder. Turn cylinder valve in counter-clockwise direction Purge air by holding control knob at "PILOT" position for at least two minutes until you smell gas. Hand tighten firmly. Check regulator and ACME1 adapter for leaks or damage Check fuel level. Replace or refill cylinder Use match to light pilot through access hole at base of heater head. Seek service or check igniter wire connections. Replace igniter if required.
The pilot after initial lighting will not stay lit	There may be a leak in the system that has been detected by the safety system in the regulator. Dirt build up around pilot orifice Thermocouple is not operating properly High wind condition blowing out pilot flame	Check connections at hose to feed line and feed line to heater head. Be sure regulator hand wheel is fully tightened going into tank. Clean pilot orifice Depress Knob in Pilot position for full 30 seconds. Replace Thermocouple Put heater in more protected location. Do not use heater in winds in excess of 10 MPH. Do not use heater in high wind conditions, rain, or at temperatures below 40 degrees F.
Main burner will not light	Gas Pressure is low Blockage in main burner orifice Safety System has detected a leak Control knob is not in "ON" position	Turn cylinder off and replace Clear Spider web or other blockage Turn tank off. Wait 5 minutes. Check both fuel line connections. Reinsert regulator tighten firmly and retry Turn knob to "ON" Position
Burner Flame Is Low or Emitter grid does not glow evenly. Please note: Bottom 1" of emitter grid normally does not glow.	Gas Pressure is low Control knob not set to "ON" Position Outdoor temperature is below 40 degrees Fahrenheit and tank is less than 20% full. Heater is not on a level surface	Turn cylinder off and refill cylinder Turn knob to "ON" Refill tank and use full cylinder better yet go inside! Reposition heater onto hard and level surface.
Carbon build up on emitter grid or thick black smoke coming from head	Dirt or film on reflector or emitter grid. Blockage in burner	Gently clean reflector or emitter Clear spider webs or debris Remove burner and remove blockage and check burner ports for blockage

Important Warnings and Safety Points!!!



For Your Safety: If you smell gas:
1. Shut off gas to appliance
2. Extinguish any open flame near the appliance. If odor continues call gas supplier.



For Your Safety:
Do not store or use gasoline or other Flammable vapor and liquids in the vicinity of this or any other appliance.



Warning!!!
Improper installation, adjustment, alteration, service, or maintenance can cause physical injury or property damage. Read the instructions thoroughly before installing, operating, or attempting to service this appliance.



Danger! *Some Important Heater Safety and Use Precautions:*
Failure to comply with the precautions and instructions provided with this heater can result in death, serious bodily injury, and property loss or damage from hazards of fire, explosion, burn, asphyxiation, and or carbon monoxide poisoning. Please be sure you understand all operating instructions before attempting to operate or service this or any appliance.

This appliance is designed and approved for outdoor use only (outside of any enclosure). Always be sure there is plenty of fresh air when the heater is in use.

- Always use extreme caution while heater is in operation. Alert both children and adults to the fact that the emitter grid will generate extremely high surface temperatures (1600 degrees plus) and will cause burns if touched. Wait at least thirty minutes before touching any hot portions of heater.
- Always maintain at least a 24" inch clearance in all directions from any combustible material.
- Please be sure heater is on a hard level surface. Be sure ballast weight is assembled into base to prevent possible tipping. **Never move the heater while it is in operation.**
- The LP (Propane) cylinder should always be turned off when the heater is not being used.
- All leak tests should be done with a soapy solution and **NEVER with a match or open flame device.**
- Do not attempt to use the heater if wind conditions exceed 10 miles per hour. It is possible that the high wind will blow the burner flame out. Position the heater so that it is not directly exposed to water spray, rain, and or dripping water or winds.
- Do not use heater if outdoor temperature is below 40 degrees F.
- Do not attempt to paint reflector, emitter grid, or any portion of the heater control assembly.
- Do not attempt to modify or alter the propane regulator that is included with your heater. It is preset at the factory for 11.0 inches water column. This is required for proper operation and safety.

- The heater is equipped specifically for use with propane gas. Do not attempt to use any other fuel unless you properly convert your heater with a factory produced gas conversion kit.
- Please keep water and sprinklers away from heater especially while in use.
- Do not use in a combustible atmosphere. Keep the heater away from areas that have flammable liquids, gasoline, vapors, or explosives stored or used. Do not use the heater inside your garage or other indoor work areas.
- Do not hang clothing or any other combustible materials on or near heater when it is in operation.
- Young children and pets should be closely supervised when the heater is in operation.
- Never hook up the heater to an unregulated propane gas supply line.
- Do not touch the emitter grid or reflector unless the heater has been turned off and cooled for at least 40 minutes.
- To avoid the possible risk of burns or possibly catching clothing or other combustible materials on fire do not touch the heater anywhere close the emitter grid or burner assembly while the heater is in operation
- Please do not attempt to clean your heater with combustible or corrosive materials.
- Minimum inlet pressure cannot exceed 100 lbs. PSI from the cylinder.
- If certain items are stored under the heater they will be subjected to the radiant heat and may be damaged.
- Do not attempt to alter the heater in any manner whatsoever. The unit has been designed to provide you with many years of trouble free service if maintained per our recommendations.
- Inspect heater before each use. If you find a damaged part, please replace the part with a genuine ***Patio Comfort*** part before using the appliance.
- Do not attempt to use your heater without the proper factory supplied hose and regulator. Use of unauthorized replacement parts may result in damage to the unit, cause improper operation, and performance, and may cause property damage or bodily injury.
- The purchaser assumes all risk in the assembly and operation of this appliance. Failure to follow this guides warnings and instructions can result in severe personal injury, property damage, or death.
- **Do NOT attempt to move heater while it is in operation.**
- Use this appliance in accordance with local codes and safety ordinances. In the absence of local codes refer to ANSI standard Z223.1
- If you have any questions whatsoever about the assembly or operation of this product please contact your authorized ***Patio Comfort*** retailer or call us directly at 949-474-3070 or E-mail aeicorp@sbcglobal.net. This product has been designed and constructed to provide you and your family with many years of safe, convenient, outdoor comfort.

Some tips on propane and the safe use of propane fuel

- Propane (LP GAS) is a very safe fuel if used properly. Propane or liquefied petroleum gas is highly flammable, explosive under pressure, clean burning, heavier than air, and settles or puddles in low areas.
- In its natural form propane gas is odorless. For your safety and for ease of detection an odorant has been added to the propane that smells like rotten cabbage. If you ever believe that you have a propane gas leak in any appliance shut off the appliance immediately and find and correct the leak.
- Direct contact with propane gas can cause freeze burns to the skin.
- Your heater is shipped from the factory to be used with propane fuel only. Do not attempt to alter your heater in any way.
- Use only a "DOT" (Department of Transportation) approved 20-pound cylinder (when it's empty) with an "ACME"TYPE 1" connection with "QCC" (Quick Connect Coupler). Use only cylinders equipped with an approved OPD "Overfill Protection Device." This device prevents accidental over-filling and possible escape of fuel when the cylinder is heated. These OPD equipped cylinders can be easily identified by their triangular handle at the top of the tank and inside and outside threads where the regulator attaches to the cylinder valve. Do NOT attempt to alter or modify any parts of this safety system!
- Never attempt to use a cylinder that has a rusted or damaged main body, a damaged collar or valve, or a damaged foot ring. Take your cylinder to an authorized propane retailer if you have any questions whatsoever about the safety or suitability of your cylinder...they're experts!
- Whenever you're not using the heater be sure to turn the tank off at the valve and the heater off at its main valve.
- **New tanks with OPD valves also contain a device that senses leaks in your heaters fuel system. If you find that the pilot light lights and ignites the burner only to find that it shuts down within a minute or two this indicates that the safety system has detected a leak in either the hose or at the various connections of the heater head. Check all fittings with a soapy solution and then attempt to re-light.**
- On all new OPD cylinders the regulator assembly and hand wheel must be completely and correctly engaged and tightened into the cylinder valve or it will not allow the gas to flow to the heater. Be sure this connection is tight but do not over-tighten. You do not need to use any tools to make this connection. You can also double-check this connection at the cylinder with a soap and water solution...never with an open flame!
- Never store a propane cylinder indoors. If you are not using the heater disconnect the cylinder from the heater and store it outdoors in an area where it is not accessible to children.
- Never paint a propane cylinder any other color than what is provided by the cylinder manufacturer.
- We recommend that you use 20 lb. OPD equipped propane cylinders made in the U.S. by either Worthington Cylinder or Manchester Tank. These are high quality propane cylinders that are constructed to the highest in manufacturing standards, safety standards, and quality standards.
- We recommend using only authorized propane filling stations or nationally recognized cylinder exchange companies. If you are unsure about the quality of the cylinder, mechanical integrity, or if the safety systems are operating properly do NOT use the cylinder and return it promptly to a qualified propane re-filler.

- If this heater is being used in a commercial or rental installation or application it is the responsibility of the purchaser to check with the local codes and ordinance officials, local fire officials, or safety officials to be sure that heaters equipped for use with propane gas are acceptable. Be sure to find out if there are specific restrictions or regulations that relate to the storage of multiple propane cylinders in a commercial installation.
- We make no claims as to the suitability of this product for any commercial or residential application.

WARNING: Chemicals known to the State of California to cause cancer, birth defects, or other reproductive harm are created by the combustion of propane and other fossil fuels.

Service & Warranty Information

To learn how to service and acquire replacement parts first contact your selling dealer/distributor or call us directly at 949-474-3070 or e-mail us at aeicorp@sbcglobal.net for assistance. Please provide us with the model number and serial ID number for best possible service and support. Please be sure to fill-out your Patio Comfort Warranty card so that we can have you on file. We will not use this information for any marketing activities.

Our company has been in the quality leisure gas appliance business since 1966 and we want to be sure that you are happy with our products and support services.

Be sure to use only genuine *Patio Comfort* replacement parts for your heater. Use of unauthorized parts or modification of our parts will void the heater warranty and could create personal injury or property damage.

Always be sure that your heater is cool to the touch before attempting any service or maintenance procedures.

Warranty

***Patio Comfort* will cover:**

***Patio Comfort* heaters are warranted against any defects in parts for a period of 1 year from the date of purchase with original purchase receipt. We will warranty against structural defects all external stainless steel components (posts, bases, & decorative covers) for 5 Years from date of purchase.**

This ONE-YEAR Consumer warranty is only applicable for consumer or residential applications. We offer a 120-day warranty protection for heaters that are used in a commercial or rental application. Commercial warranty does NOT cover emitters, ignition, or burners) or component failure caused by abuse, transportation, or misuse.

This warranty is valid from the original date of purchase and is transferable. Please keep your original sales receipt or invoice. Proof of purchase is required to obtain warranty replacement. *Patio Comfort* retail dealers or distributors do NOT have the authority to modify, alter, or in any way change the product or the terms and conditions of this warranty.

We will NOT cover the following:

- Freight charges to our facility in Irvine, California (We will pay all return freight costs)
- Assembly or installation costs
- Improper assembly or improper hook-up
- Damage or repairs that result from spiders or other insect nesting
- Damage due to weather conditions or lack of proper maintenance and cleaning
- Normal maintenance or burner adjustments
- Cleaning or period general maintenance
- Shipping or freight damage
- Service provided by an unauthorized agency or service person

- Overtime, weekends, and holidays
- Service visits to correct improper assembly or installation.
- Damages caused by abuse, accident, acts of nature, vandalism, transportation, or alteration
- We will not repair rented heaters that have been repurchased for residential use
- *We will not cover normal wear and tear such as discoloration to the finish, scratches, chips, abrasion, or fading from exposure to sunlight or other atmospheric conditions.*

Your Legal Rights

- **CONSEQUENTIAL DAMAGES, INCIDENTAL DAMAGES, OR EXPENSES INCLUDING DAMAGES TO PROPERTY. SOME STATES/PROVINCES DO NOT ALLOW THE EXCLUSION OR LIMITATION OF INCIDENTAL OR CONSEQUENTIAL DAMAGES, SO THE ABOVE LIMITATION OR EXCLUSION MAY NOT APPLY TO YOU. WE WILL NOT BE RESPONSIBLE FOR ANY COSTS RELATING TO LOST REVENUE, BUSINESS INTERRUPTION, OR ANY LEGAL THEORY UPON WHICH ANY CLAIM MAY BE BASED.**
- **PURCHASER ASSUMES ALL RISK IN THE ASSEMBLY AND OPERATION OF THIS APPLIANCE. FAILURE TO FOLLOW THIS MANUAL'S WARNINGS AND INSTRUCTIONS CAN RESULT IN SEVERE PERSONAL INJURY, DEATH, OR PROPERTY DAMAGE**

This warranty is for all *Patio Comfort* heaters purchased and used in the 50 US states, The District of Columbia and Canada. This warranty applies even if you should move during the warranty period. Should you sell the product during the warranty period the warranty protects the new owner as well. This warranty provides you with specific legal rights. You may also have other rights that vary from state to state.

How to obtain service:

For most product or assembly related problems your selling dealer can provide you with help. The product has been designed to be as trouble-free and maintenance free as possible and requires minimal assembly. Should you have a problem with missing parts please contact your selling dealer or contact us directly at 949-474- 3070. We exercise extreme care in the assembly and manufacturing process but we know errors can be made and we want to take care of them as quickly and painlessly as possible.

Since product improvement is an ongoing process we reserve the right to change this products materials, specifications, or design without notice. We know that you and your family will enjoy your *Patio Comfort* heating product for many years to come and that it will be a welcome addition and important ingredient to your outdoor entertainment and activities.

AEI Corporation
PO Box 16097
Irvine, California 92623-6097
Phone 949-474-3070 email aeicorp@sbcglobal.net
Official Website: www.patiocomfortheaters.com

Phone 949 474-3070
Fax 949 474-0559

Patio Comfort Vintage Heater Warranty Registration Form

Please return this warranty registration card within 10 days

Congratulations on purchasing a *Patio Comfort* Model PC-02 **Vintage Series** Outdoor Heater. To ensure that you'll get all of the warranty protection that comes with the purchase of this fine product please fill out the Warranty Registration Form and send it back to us **within 10 days of purchase**.

Rest assured that your registration information is for our information and tracking only and will NOT be used by any other company or organization. Appliance manufacturers are required to keep detailed design, component, production, testing, and manufacturing information in the event there is ever a defective part or we need to quickly contact our customers regarding any added safety information regarding our products. Your cooperation in this tracking system is extremely important. Please fill out the information below as completely as possible.

Last Name _____ First Name _____ Middle Initial _____

Date Of Purchase _____

Model Of Heater _____ Fuel Type _____

Serial Number of Heaters Purchased:

Name Of Selling Dealer _____

Address Of Selling Dealer _____

Your Home Address _____ State _____ Zip _____

E-mail address (optional) _____

Thanks again for your purchase please mail this today so that we can activate your warranty information.

Please mail to:

AEI Corporation
C/O Warranty Registration Department-Patio Comfort
PO Box 16097
Irvine, California 92623-6097
Phone 949-474-3070 email aeicorp@sbcglobal.net
Official Website: www.patiocomfortheaters.com