

56852

Evaluation Module User Manual

56F850
16-bit Digital Signal Controllers

DSP56852EVMUM
Rev. 3
07/2005

freescale.com



TABLE OF CONTENTS

Preface vii

Chapter 1 Introduction

1.1	56852EVM Architecture	1-1
1.2	56852EVM Configuration Jumpers	1-2
1.3	56852EVM Connections	1-4

Chapter 2 Technical Summary

2.1	56852	2-2
2.2	Program and Data Memory	2-3
2.2.1	SRAM Bank 0	2-3
2.2.2	SRAM Bank 1	2-3
2.3	SPI Serial EEPROM/Data FLASH Memory	2-5
2.4	RS-232 Serial Communications	2-6
2.5	Clock Source	2-7
2.6	Operating Mode	2-8
2.7	Debug LEDs	2-8
2.8	Debug Support	2-9
2.8.1	JTAG Connector	2-10
2.8.2	Parallel JTAG Interface Connector	2-11
2.9	External Interrupts	2-13
2.10	Reset	2-14
2.11	Power Supply	2-15
2.12	Stereo Codec	2-16
2.12.1	Analog Input/Output	2-17
2.12.2	Digital Interface	2-17
2.13	Daughter Card Connectors	2-19
2.13.1	Memory Daughter Card Expansion Connector	2-19
2.13.2	Peripheral Daughter Card Expansion Connector	2-21
2.14	Test Points	2-22



Appendix A
DSP56852EVM Schematics

Appendix B
DSP56852EVM Bill of Material

LIST OF FIGURES

1-1	Block Diagram of the 56852EVM.	1-2
1-2	56F801EVM Jumper Reference	1-3
1-3	Connecting the 56852EVM Cables	1-4
2-1	Schematic Diagram of the External CS0 Memory Interface.	2-3
2-2	Schematic Diagram of the External CS1/CS2 Memory Interface.	2-4
2-3	SPI EEPROM Memory Block Diagram	2-5
2-4	Schematic Diagram of the RS-232 Interface.	2-6
2-5	Schematic Diagram of the Clock Interface	2-7
2-6	Schematic Diagram of the Debug LED Interface	2-9
2-7	Block Diagram of the Parallel JTAG Interface	2-11
2-8	Schematic Diagram of the User Interrupt Interface.	2-13
2-9	Schematic Diagram of the RESET Interface.	2-14
2-10	Schematic Diagram of the Power Supply	2-15
2-11	Codec Analog Connections	2-17
2-12	CS4218 Stereo Audio Codec.	2-18



LIST OF TABLES

1-1	56F801EVM Default Jumper Options	1-3
2-1	SPI Port Connector Description	2-5
2-2	RS-232 Serial Connector Description	2-6
2-3	Operating Mode Selection	2-8
2-4	LED Control	2-8
2-5	JTAG Connector Description	2-10
2-6	Parallel JTAG Interface Disable Jumper Selection	2-10
2-7	Parallel JTAG Interface Connector Description	2-12
2-8	Codec Sample Rate Selector	2-16
2-9	SSI Port Connector Description	2-18
2-10	GPIO Port Connector Description	2-19
2-11	Memory Daughter Card Connector Description	2-19
2-12	Peripheral Daughter Card Connector Description	2-21



Preface

This reference manual describes in detail the hardware on the 56852 Evaluation Module.

Audience

This document is intended for application developers who are creating software for devices using the Freescale 56852 part.

Organization

This manual is organized into two chapters and two appendixes.

- **Chapter 1, Introduction** - provides an overview of the EVM and its features.
- **Chapter 2, Technical Summary** - describes in detail the 56852 hardware.
- **Appendix A, DSP56852EVM Schematics** - contains the schematics of the 56852EVM.
- **Appendix B, DSP56852EVM Bill of Material** - provides a list of the materials used on the 56852EVM board.

Suggested Reading

More documentation on the 56852 and the 56852EVM kit may be found at URL:

www.freescale.com

Conventions

This manual uses the following notational conventions:

Term or Value	Symbol	Examples	Exceptions
Active High Signals (Logic One)	No special symbol attached to the signal name	A0 CLKO	
Active Low Signals (Logic Zero)	Noted with an overbar in text and in most figures	\overline{WE} OE	In schematic drawings, Active Low Signals may be noted by a backslash: /WE
Hexadecimal Values	Begin with a "\$" symbol	\$0FF0 \$80	
Decimal Values	No special symbol attached to the number	10 34	
Binary Values	Begin with the letter "b" attached to the number	b1010 b0011	
Numbers	Considered positive unless specifically noted as a negative value	5 -10	Voltage is often shown as positive: +3.3V
Blue Text	Linkable on-line	...refer to Chapter 7, License	
Bold	Reference sources, paths, emphasis	...see: www.freescale.com	

Definitions, Acronyms, and Abbreviations

Definitions, acronyms and abbreviations for terms used in this document are defined below for reference.

Codec	COder/DECoder; a part used to convert analog signals to digital (coder) and digital signals to analog (decoder)
DSP	Digital Signal Processor or Digital Signal Processing
EEPROM	Electrically Erasable Programmable Read-Only Memory
EOnCE	Enhanced On-Chip Emulation; a debug bus and port created by Freescale to enable a designer to create a low-cost hardware interface for a professional-quality debug environment
EVM	Evaluation Module; a hardware platform which allows a customer to evaluate the silicon and develop his application
GPIO	General Purpose Input and Output port on Freescale's family of controllers; does not share pin functionality with any other peripheral on the chip and can only be set as an input, output or level-sensitive interrupt input
IC	Integrated Circuit
ISSI	Improved Synchronous Serial Interface port on Freescale's family of controllers
JTAG	Joint Test Action Group; a bus protocol/interface used for test and debug
LED	Light Emitting Diode
MBGA	MAP Ball Grid Array package
MPIO	Multi Purpose Input and Output port on Freescale's family of controllers; shares package pins with other peripherals on the chip and can function as a GPIO
PCB	Printed Circuit Board
PLL	Phase Locked Loop
RAM	Random Access Memory
ROM	Read Only Memory
SCI	Serial Communications Interface port on Freescale's family of controllers



SPI	Serial Peripheral Interface port on Freescale's family of controllers
SRAM	Static Random Access Memory
SSI	Synchronous Serial Interface port on Freescale's family of controllers
WS	Wait State

References

The following sources were referenced to produce this manual:

- [1] *DSP56800E Reference Manual*, Freescale Semiconductor
- [2] *DSP56852 Digital Signal Processor User's Manual*, Freescale Semiconductor
- [3] *DSP56852 Digital Signal Processor Technical Data*, Freescale Semiconductor

Chapter 1

Introduction

The 56852EVM is used to demonstrate the abilities of the 56852 and to provide a hardware tool allowing the development of applications that use the 56852.

The 56852EVM is an evaluation module board that includes a 56852 part, 16-bit stereo codec, external memory and a daughter card expansion interface. The daughter card expansion connectors are for signal monitoring and user feature expandability.

The 56852EVM is designed for the following purposes:

- Allowing new users to become familiar with the features of the 56800E architecture. The tools and examples provided with the 56852EVM facilitate evaluation of the feature set and the benefits of the family.
- Serving as a platform for real-time software development. The tool suite enables the user to develop and simulate routines, download the software to on-chip or on-board RAM, run it, and debug it using a debugger via the JTAG/Enhanced OnCE (EOnCE) port. The breakpoint features of the EOnCE port enable the user to easily specify complex break conditions and to execute user-developed software at full speed until the break conditions are satisfied. The ability to examine and modify all user-accessible registers, memory and peripherals through the EOnCE port greatly facilitates the task of the developer.
- Serving as a platform for hardware development. The hardware platform enables the user to connect external hardware peripherals. The on-board peripherals can be disabled, providing the user with the ability to reassign any and all of the controller's peripherals. The EOnCE port's unobtrusive design means that all memory on the board and on the chip is available to the user.

1.1 56852EVM Architecture

The 56852EVM facilitates the evaluation of various features present in the 56852 part. The 56852EVM can be used to develop real-time software and hardware products based on the 56852. The 56852EVM provides the features necessary for a user to write and debug software,

demonstrate the functionality of that software and interface with the customer's application-specific device(s). The 56852EVM is flexible enough to allow a user to fully exploit the 56852's features to optimize the performance of their product, as shown in **Figure 1-1**.

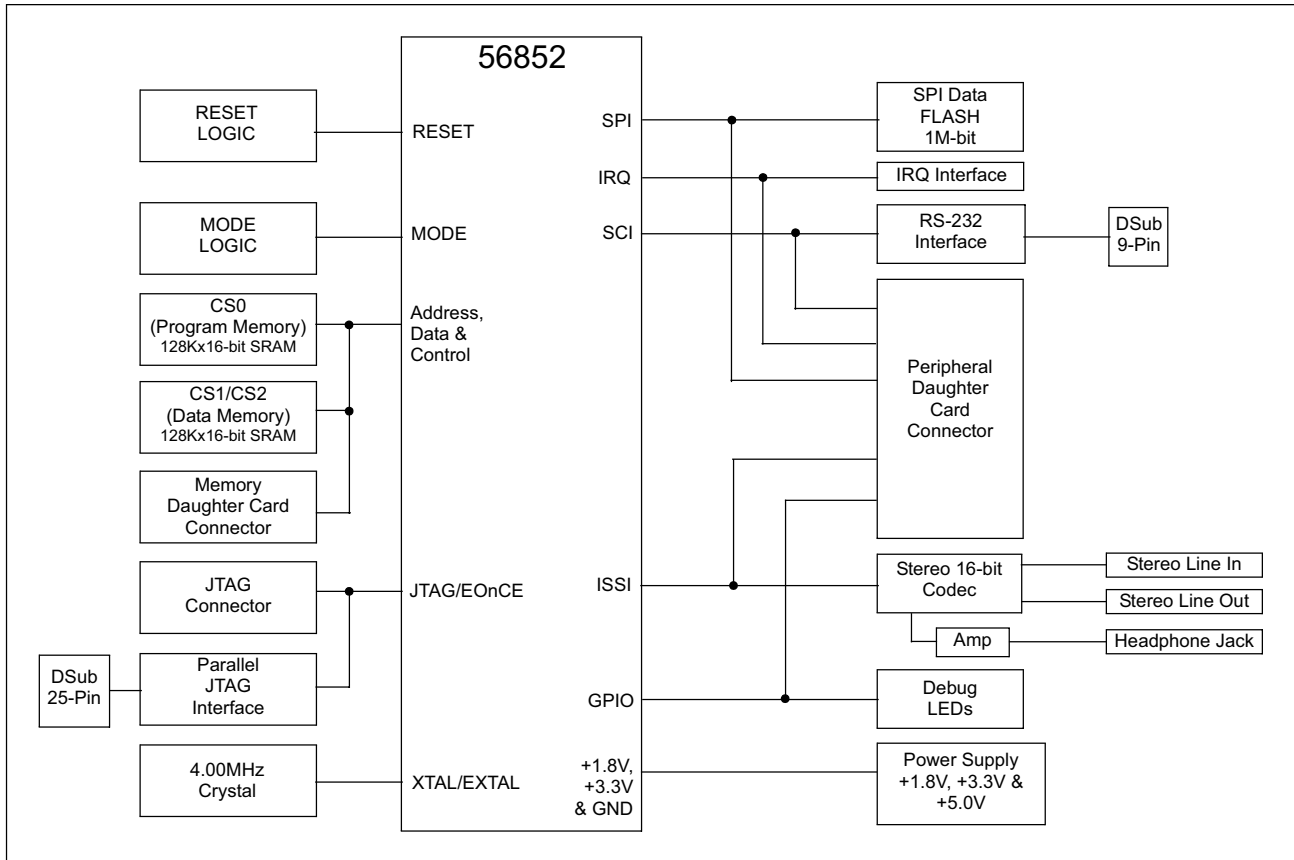

Figure 1-1. Block Diagram of the 56852EVM

1.2 56852EVM Configuration Jumpers

Ten jumper groups, (JG1-JG10), shown in **Figure 1-2**, are used to configure various features on the 56852EVM board. **Table 1-1** describes the default jumper group settings.

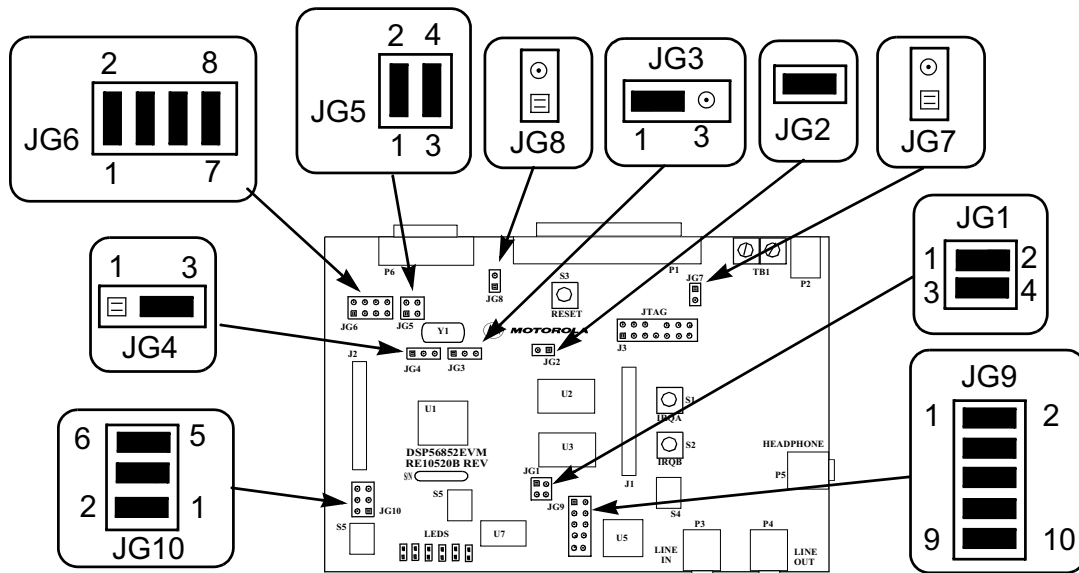

Figure 1-2. 56F801EVM Jumper Reference

Table 1-1. 56F801EVM Default Jumper Options

Jumper Group	Comment	Jumpers Connections
JG1	Enable on-board Byte selectable SRAM via CS1/CS2 (U3)	1-2, 3-4
JG2	Enable on-board Word selectable SRAM via CS0 (U2)	1-2
JG3	Use on-board XTAL crystal input for oscillator	1-2
JG4	Use on-board EXTAL crystal input for oscillator	2-3
JG5	Enable SCI Port to RS-232 transceiver	1-2, 3-4
JG6	Enable SPI Port to Serial EEPROM/Data FLASH	1-2, 3-4, 5-6 & 7-8
JG7	Enable on-board Parallel JTAG Host/Target Interface	NC
JG8	Enable RS-232 output	NC
JG9	Enable SSI Port for CODEC data.	1-2, 3-4, 5-6, 7-8, 9-10
JG10	Enable GPIO for CODEC control.	1-2, 3-4, 5-6

1.3 56852EVM Connections

An interconnection diagram is shown in **Figure 1-3** for connecting the PC and the external +12.0V DC/AC power supply or external +5.0V DC lab power supply to the 56852EVM board.

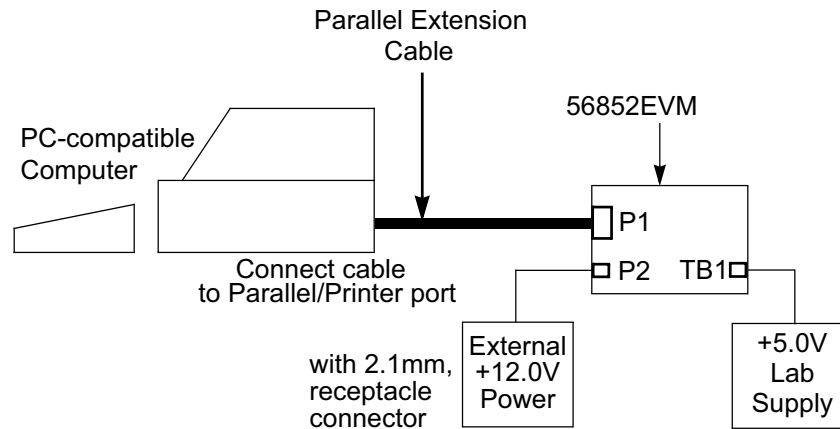

Figure 1-3. Connecting the 56852EVM Cables

Perform the following steps to connect the 56852EVM cables:

1. Connect the parallel extension cable to the Parallel port of the host computer.
2. Connect the other end of the parallel extension cable to P1, shown in **Figure 1-3**, on the 56F801EVM board. This provides the connection which allows the host computer to control the board.
3. Make sure that the external +12.0V DC 1.2A switching power supply or the external +5.0V DC 1A lab power supply is not plugged into a +120V AC power source.
4. Connect the 2.1mm output power plug from the external switching power supply into P2, shown in **Figure 1-3**, on the 56852EVM board. Optionally, attach an external +5.0V DC lab power supply via the 2-pin terminal block, TB1.
5. Apply power to the external power supply. The green Power-On LED, LED7, will illuminate when power is correctly applied.

Chapter 2

Technical Summary

The 56852EVM is designed as a versatile controller development card for developing real-time software and hardware products to support a new generation of applications in digital and wireless messaging, digital answering machines, feature phones, modems, and digital cameras. The power of the 16-bit 56852, combined with the on-board 128K × 16-bit external program/data static RAM (SRAM), 128K × 16-bit external data/program SRAM, RS-232 interface, stereo 16-bit codec interface, Daughter Card Expansion interface and parallel JTAG interface, makes the 56852EVM ideal for developing and implementing many audio and voice algorithms, as well as for learning the architecture and instruction set of the 56852 processor.

The main features of the 56852EVM, with board and schematic reference designators include:

- 56852 16-bit +1.8V/+3.3V Digital Signal Processor operating at 120MHz [U1]
- External fast static RAM (FSRAM) memory, configured as:
 - 128K×16-bit of memory [U2] with 1 wait state at 120MHz via CS0
 - 128K×16-bit of memory [U3] with 1 wait state at 120MHz via CS1/CS2
- 1M-bit Serial EEPROM/Data FLASH [U4]
- 4.00MHz crystal oscillator for controller frequency generation [Y1]
- Optional external oscillator frequency input connectors [JG3 and JG4]
- Joint Test Action Group (JTAG) port interface connector for an external debug Host Target Interface [J3]
- On-board Parallel JTAG Host Target Interface, with a connector for a PC printer port cable [P1]
- RS-232 interface for easy connection to a host processor [U6 and P6]
- 16-bit stereo codec interface [U5, JG9, JG10, P3 and P4]
- Stereo headphone interface [U12 and P5]

- Codec sample rate selector [S4]
- Peripheral Daughter Card Expansion Connector, to allow the user to connect his own SCI, ISSI, SPI or GPIO-compatible peripheral to the controller [J2]
- Memory Daughter Card Expansion Connector, to allow the user to connect his own memory or memory device to the controller [J1]
- On-board power regulation from an external +12V DC-supplied power input [P2]
- On-board power regulation from an optional +5V DC-supplied power input [TB1]
- Light Emitting Diode (LED) power indicator [LED7]
- Six on-board real-time user debugging LEDs [LED1-6]
- Boot MODE selector [S5]
- Manual RESET push-button [S3]
- Manual interrupt push-button for $\overline{\text{IRQA}}$ [S1]
- Manual interrupt push-button for $\overline{\text{IRQB}}$ [S2]

2.1 56852

The 56852EVM uses a Freescale DSP56852VF120 part, designated as U1 on the board and in the schematics. This part will operate at a maximum speed of 120MHz. A full description of the 56852, including functionality and user information, is provided in these documents:

- *DSP56852 Technical Data*, (DSP56852): Provides features list and specifications, including signal descriptions, DC power requirements, AC timing requirements and available packaging
- *DSP56852 User's Manual*, (DSP56852UM): Provides an overview description of the controller and detailed information about the on-chip components, including the memory and I/O maps, peripheral functionality, and control/status register descriptions for each subsystem
- *DSP56800E Reference Manual*, (DSP56800ERM): Provides a detailed description of the core processor, including internal status and control registers and a detailed description of the family instruction set

Refer to these documents for detailed information about chip functionality and operation. They can be found on this URL:

www.freescale.com

2.2 Program and Data Memory

The 56852EVM contains two 128Kx16-bit Fast Static RAM banks. SRAM bank 0 is controlled by CS0 and SRAM bank 1 is controlled by CS1 and CS2.

2.2.1 SRAM Bank 0

SRAM bank 0, which is controlled by CS0, uses a 128Kx16-bit Fast Static RAM (GSI GS72116, labeled U2) for external memory expansion; see the FSRAM schematic diagram in [Figure 2-1](#). CS0 can be configured to use this memory bank as 16-bit program memory, data memory, or both. Additionally, CS0 can be configured to assign this memory's size and starting address to any modulo address space.

This memory bank will operate with one wait state access while the 56852 is running at 120MHz and can be disabled by removing the jumper at JG2.

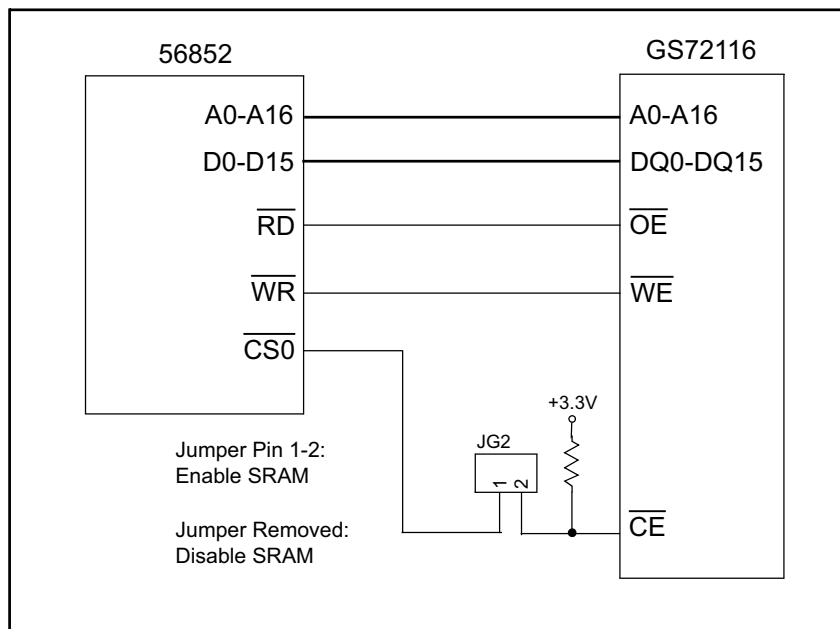

Figure 2-1. Schematic Diagram of the External CS0 Memory Interface

2.2.2 SRAM Bank 1

SRAM bank 1, which is controlled by CS1 and CS2, uses a 128Kx16-bit Fast Static RAM (GSI GS72116, labelled U3) for external memory expansion; see the FSRAM schematic diagram in [Figure 2-2](#). Using CS1 and CS2, this memory bank can be configured as byte (8-bit) or word (16-bit) accessible program memory, data memory, or both. Additionally, CS1 and CS2 can be configured to assign this memory's size and starting address to any modulo address space.

This memory bank will operate with one wait state access while the 56852 is running at 120MHz and can be disabled by removing the jumpers at JG1.

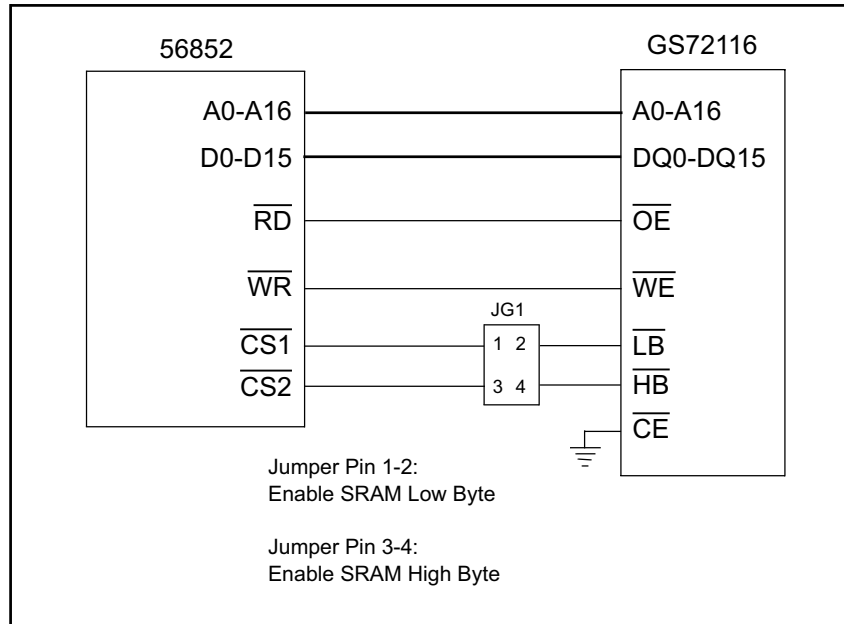

Figure 2-2. Schematic Diagram of the External CS1/CS2 Memory Interface

2.3 SPI Serial EEPROM/Data FLASH Memory

A 1M-bit +3.3V SPI serial EEPROM/Data FLASH Memory, Atmel AT45DB011B-SC, is provided on the 56852EVM, reference [Figure 2-3](#). This memory connects directly to the SPI Port through a header on the 56852. It can be used to load program code and data into the 56852's internal or external memory spaces. Jumper block JG6 is provided to allow the user to disconnect the on-board SPI EEPROM/Data FLASH from the SPI port and allow him to connect his own SPI port peripheral. Since the SPI port and ISSI port are multiplexed on the 56852, the SPI port jumpers need to be removed to use the ISSI port. The header details are shown in [Table 2-1](#).

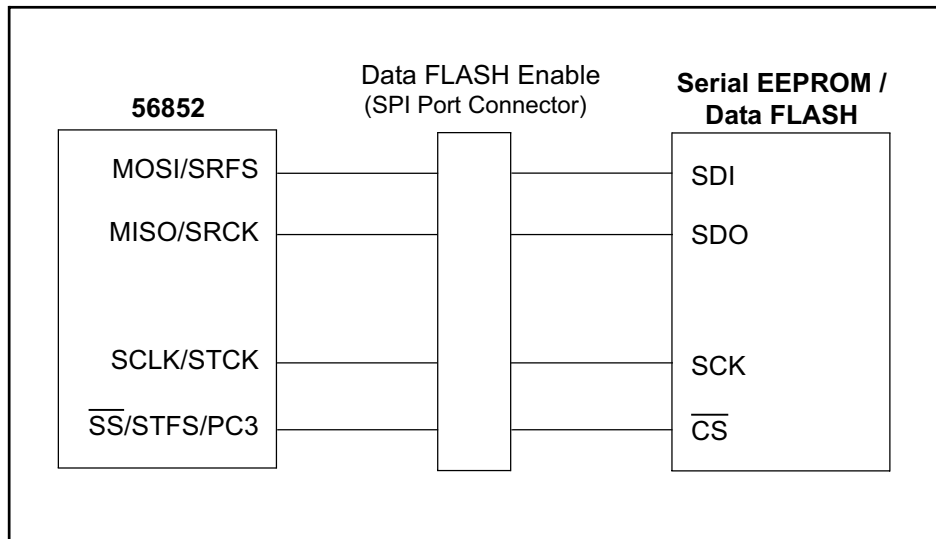

Figure 2-3. SPI EEPROM Memory Block Diagram

Table 2-1. SPI Port Connector Description

JG6			
Pin #	Signal	Pin #	Signal
1	$\overline{\text{SS}}/\text{STFS}/\text{PC3}$	2	$\overline{\text{CS}}$
3	MISO/SRCK	4	SDO
5	MOSI/SRFS	6	SDI
7	SCLK/STCK	8	SCK

2.4 RS-232 Serial Communications

The 56852EVM provides an RS-232 interface by the use of an RS-232 level converter, (Maxim MAX3245EEAI, designated as U6). Refer to the RS-232 schematic diagram in **Figure 2-4**. The RS-232 level converter transitions the SCI UART's +3.3V signal levels to RS-232-compatible signal levels and connects to the host's serial port via connector P6. Flow control is not provided, but could be implemented using uncommitted GPIO signals. The pinout of connector P6 is listed in **Table 2-2**. The RS-232 level converter/transceiver can be disabled by placing a jumper at JG8.

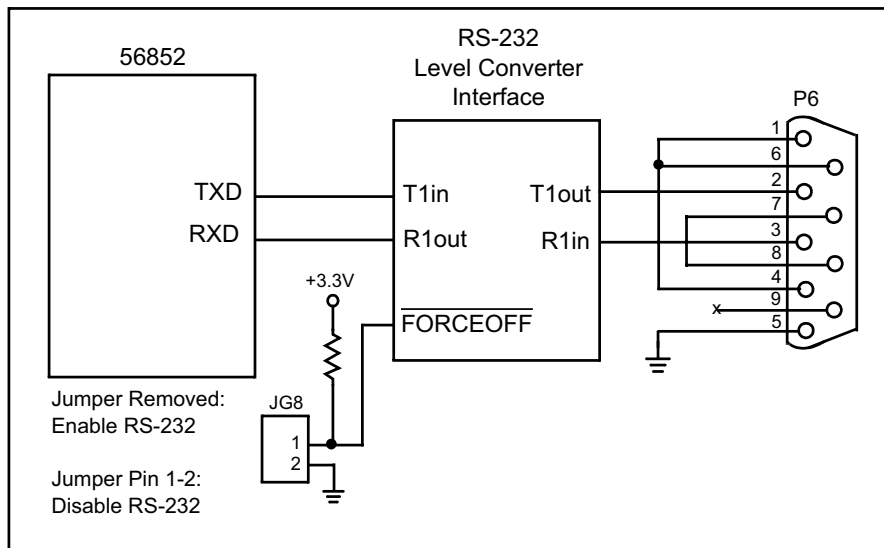

Figure 2-4. Schematic Diagram of the RS-232 Interface

Table 2-2. RS-232 Serial Connector Description

P6			
Pin #	Signal	Pin #	Signal
1	Jumper to 6 & 4	6	Jumper to 1 & 4
2	TXD	7	Jumper to 8
3	RXD	8	Jumper to 7
4	Jumper to 1 & 6	9	N/C
5	GND		

2.5 Clock Source

The 56852EVM uses a 4.00MHz crystal, Y1, connected to its External Crystal Inputs, EXTAL and XTAL. To achieve its 120MHz maximum operating frequency, the 56852 uses its internal PLL to multiply the input frequency by 30. An external oscillator source can be connected to the controller by using the oscillator bypass connectors, JG3 and JG4; see **Figure 2-5**. If the input frequency is above 4MHz, then the EXTAL input should be jumpered to ground by adding a jumper between JG4 pins 1 and 2. The input frequency would then be injected on JG3's pin 2. If the controller needs to be synchronized to the codec's sample frequency, then the controller's input frequency should be jumpered using the 12.2280MHz codec frequency. If the input frequency is below 4MHz, then the input frequency can be injected on JG4's pin 2.

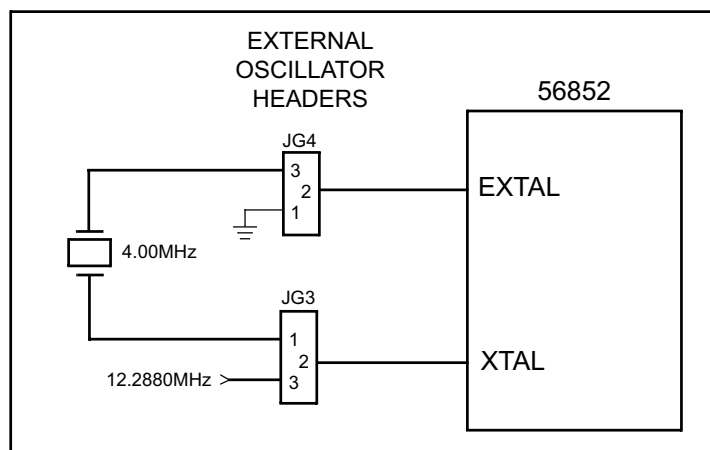

Figure 2-5. Schematic Diagram of the Clock Interface

2.6 Operating Mode

The 56852EVM provides a boot-up MODE selection switch, S5. This switch is used to select the operating mode of the controller as it exits RESET. Refer to the DSP56852 User's Manual for a complete description of the chip's operating modes. [Table 2-3](#) shows the two operation modes available on the 56852.

Table 2-3. Operating Mode Selection

Operating Mode	S5 (ON)	Comment
0	1-2, 3-4 & 5-6	Bootstrap from External byte-wide memory
1	3-4 & 5-6	Bootstrap from SPI
2	1-2 & 5-6	Normal Expanded mode
3	5-6	Development Expanded mode

2.7 Debug LEDs

Six on-board Light-Emitting Diodes, (LEDs), are provided to allow real-time debugging for user programs. These LEDs will allow the programmer to monitor program execution without having to stop the program during debugging; refer to [Figure 2-6](#). [Table 2-4](#) describes the control of each LED.

Table 2-4. LED Control

User LED	Controlled by	
	Port	Signal
LED1	Port A	PA2
LED2	Port C	PC4
LED3	Port C	PC5
LED4	Port C	PC3
LED5	Port E	PE1
LED6	Port E	PE0

Setting PA2, PC4, PC5, PC3, PE1 or PE0 to a Logic One value will turn on the associated LED.

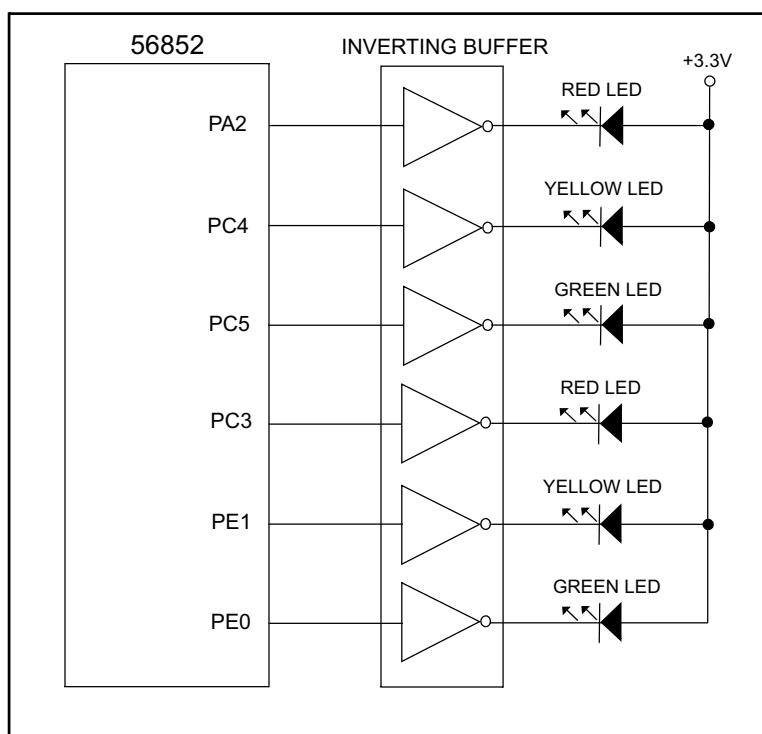

Figure 2-6. Schematic Diagram of the Debug LED Interface

2.8 Debug Support

The 56852EVM provides an on-board Parallel JTAG Host Target Interface and a JTAG interface connector for external Target Interface support. Two interface connectors are provided to support each of these debugging approaches. These two connectors are designated the JTAG connector and the Host Parallel Interface Connector.

2.8.1 JTAG Connector

The JTAG connector on the 56852EVM allows the connection of an external Host Target Interface for downloading programs and working with the 56852's registers. This connector is used to communicate with an external Host Target Interface which passes information and data back and forth with a host processor running a debugger program. [Table 2-5](#) shows the pin-out for this connector.

Table 2-5. JTAG Connector Description

J3			
Pin #	Signal	Pin #	Signal
1	TDI	2	GND
3	TDO	4	GND
5	TCK	6	GND
7	NC	8	KEY
9	$\overline{\text{RESET}}$	10	TMS
11	+3.3V	12	NC
13	$\overline{\text{DE}}$	14	$\overline{\text{TRST}}$

When this connector is used with an external Host Target Interface, the parallel JTAG interface should be disabled by placing a jumper in jumper block JG7. Reference [Table 2-6](#) for this jumper's selection options.

Table 2-6. Parallel JTAG Interface Disable Jumper Selection

JG7	Comment
No jumpers	On-board Parallel JTAG Interface Enabled
1-2	Disable on-board Parallel JTAG Interface

2.8.2 Parallel JTAG Interface Connector

The Parallel JTAG Interface Connector, P1, allows the 56852 to communicate with a Parallel Printer Port on a Windows PC; reference [Figure 2-7](#). Using this connector, the user can download programs and work with the 56852's registers. [Table 2-7](#) shows the pin-out for this connector. When using the parallel JTAG interface, the jumper at JG7 should be removed, as shown in [Table 2-6](#).

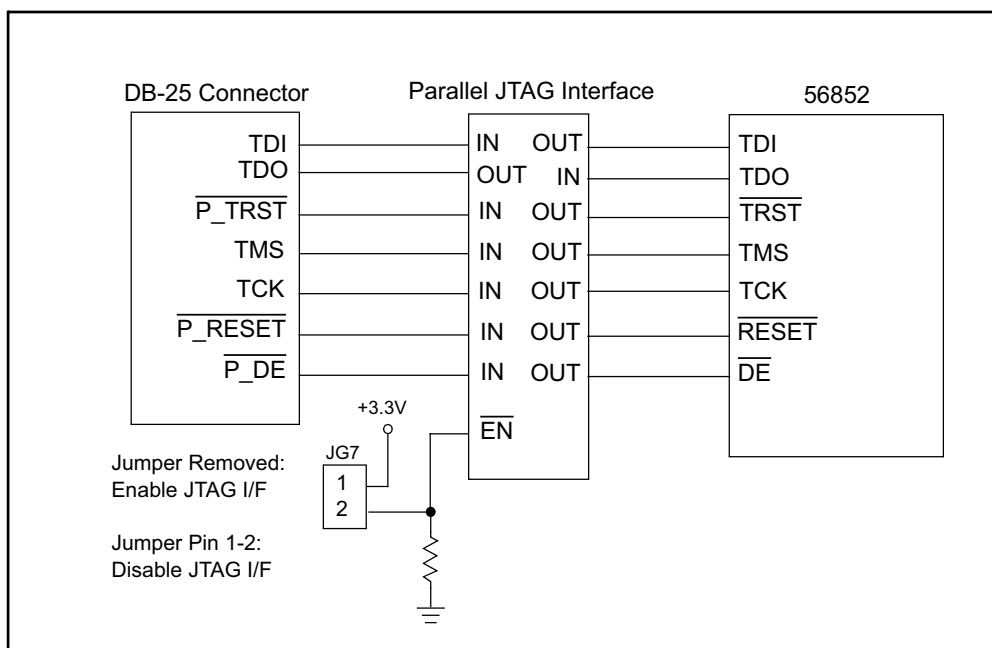

Figure 2-7. Block Diagram of the Parallel JTAG Interface

Table 2-7. Parallel JTAG Interface Connector Description

P1			
Pin #	Signal	Pin #	Signal
1	NC	14	NC
2	PORT_RESET	15	PORT_IDENT
3	PORT_TMS	16	NC
4	PORT_TCK	17	NC
5	PORT_TDI	18	GND
6	$\overline{\text{PORT_TRST}}$	19	GND
7	$\overline{\text{PORT_DE}}$	20	GND
8	PORT_IDENT	21	GND
9	PORT_VCC	22	GND
10	NC	23	GND
11	PORT_TDO	24	GND
12	NC	25	GND
13	PORT_CONNECT		

2.9 External Interrupts

Two on-board push-button switches are provided for external interrupt generation, as shown in **Figure 2-8**. S1 allows the user to generate a hardware interrupt for signal line $\overline{\text{IRQA}}$. S2 allows the user to generate a hardware interrupt for signal line $\overline{\text{IRQB}}$. These two switches allow the user to generate interrupts for his user-specific programs.

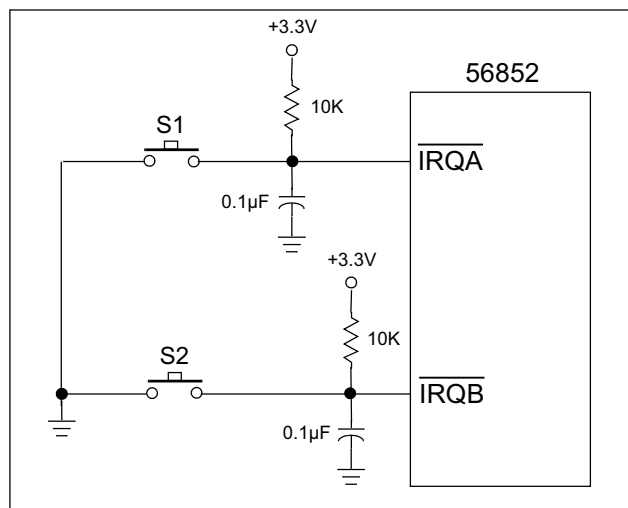

Figure 2-8. Schematic Diagram of the User Interrupt Interface

2.10 Reset

Logic is provided on the 56852 to generate an internal Power-On RESET. Additional, reset logic is provided to support the RESET signals from the JTAG connector, the Parallel JTAG Interface and the user RESET push-button; refer to [Figure 2-9](#).

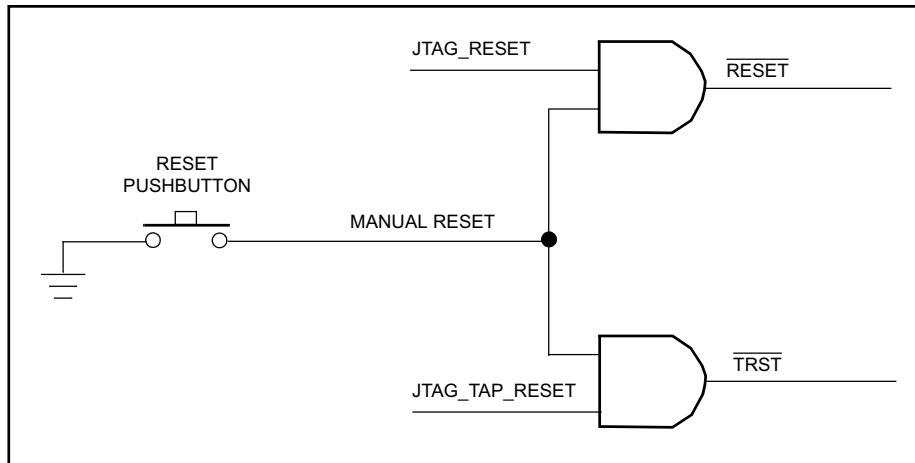

Figure 2-9. Schematic Diagram of the RESET Interface

2.11 Power Supply

The main power input, +12.0V DC/AC, to the 56852EVM is through a 2.1mm coax power jack. An optional +5.0V DC power supply input is available through a 2-pin terminal block, TB1. A +12.0V DC 1.2A power supply is provided with the 56852EVM; however, less than 500mA is required by the EVM. The remaining current is available for user daughter card applications when connected to the daughter card interface. The power regulation on the 56852EVM provides +5.0V DC voltage regulation for the codec's analog circuits and to the additional voltage regulation logic on the EVM. The additional voltage regulation logic provides +1.8V DC voltage regulation for the controller's core and +3.3V DC voltage regulation for the controller's I/O, memory, parallel JTAG interface and supporting logic; refer to [Figure 2-10](#). Power applied to the 56852EVM is indicated with a Power-On LED, referenced as LED7.

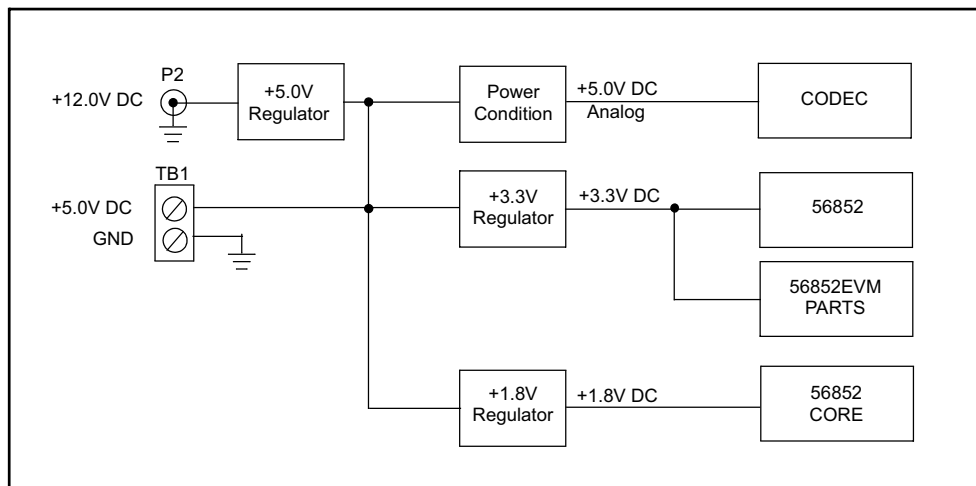

Figure 2-10. Schematic Diagram of the Power Supply

2.12 Stereo Codec

A 16-bit audio quality stereo codec, Crystal Semiconductor CS4218, is connected to the 56852's ISSI port to support audio, voice and signal analysis applications. The codec is clocked with a 12.288MHz oscillator. This allows the codec to operate between a sample frequency of 8KHz and 48KHz. The sample rate can be manually set by setting the appropriate switch positions on DIP switch S4. The sample rate selections possible using this three-position DIP switch are detailed in [Table 2-8](#). The codec supports +3.3V digital levels, eliminating the need for voltage level translation circuitry. Additionally, a set of zero ohm resistors are provided on the EVM to allow a user to disconnect the on-board codec from the ISSI port and allow him to connect his own codec to the ISSI port; see [Figure 2-12](#). The on-board codec has analog signal conditioning logic, allowing direct connection to its line level input and line level output signals through two 1/8" stereo jacks; reference [Figure 2-11](#).

Table 2-8. Codec Sample Rate Selector

SW 4 Position 3 (MF6)	SW 4 Position 2 (MF7)	SW 4 Position 3 (MF8)	Sample Rate
ON	ON	ON	48.00KHz
ON	ON	OFF	32.00KHz
ON	OFF	ON	24.00KHz
ON	OFF	OFF	19.20KHz
OFF	ON	ON	16.00KHz
OFF	ON	OFF	12.00KHz
OFF	OFF	ON	9.60KHz
OFF	OFF	OFF	8.00KHz

2.12.1 Analog Input/Output

The 56852EVM uses jacks for line-level stereo input, line-level stereo output and stereo headphone output. A National Semiconductor LM4880 provides the drive required for the use of headphones. This device offers a THD, which is superior by a factor of two to the CS4218's on-chip headphone drive circuitry. The basic Analog codec connections are shown in [Figure 2-11](#).

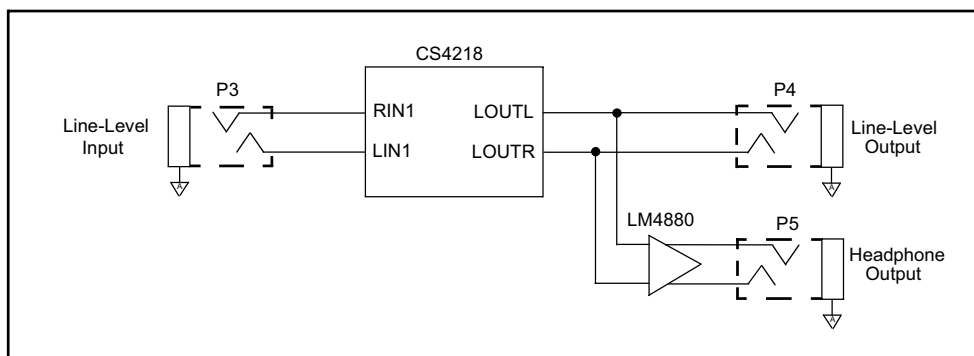

Figure 2-11. Codec Analog Connections

2.12.2 Digital Interface

The serial interface of the codec transfers digital audio data and control data into and out of the device. The ISSI port, which is multiplexed with the SPI port, consists of independent transmitter and receiver sections and is used for serial communication with the codec.

On the controller side, the Serial Transmit Data pin, STXD, is an output when data is being transmitted to the codec. The Serial Receive Data pin, SRXD, is an input when data is being received from the codec. These two pins are connected to the codec's Serial Data Input, SDIN, and Serial Data Output, SDOUT, pins.

The controller's Transmit Serial Clock pin, STCK, provides the serial bit rate clock for the ISSI interface. It is connected to the CODEC's Serial Port Clock pin, SCLK. Data is transmitted on the rising edge of SCLK and is received on the falling edge of SCLK.

The controller's GPIO PORT C Bit 4 pin, PC4, is programmed to control the codec's Active Low Reset signal, RESET.

The Serial Transmit Frame Sync pin, STFS, is programmed to control the codec's Frame Sync signal, FSYNC. This signal is sampled by SCLK, with a rising edge indicating a new frame is about to start. The FSYNC frequency is always the system's sample rate. It may be an input to the codec, or it may be an output from the codec in data mode.

The basic codec digital connections are shown in **Figure 2-12**, **Table 2-9** and **Table 2-10**.

The codec's MODE is set by the three MODE selection resistors, R66-R68. In the factory default setting of MODE 4, the codec is set to be the Master of the ISSI bus with its data word set at 32 bits per frame; i.e., 16 bits Left channel and 16 bits Right channel. The sample rate is selected on the Sample Rate Selector switch S4; see **Table 2-8** for selection options. Codec control information is sent over a separate serial port using: PC5 as the Control Chip Select signal, CCS; PE0 as the Control Data Input signal, CDIN; and PE1 as the Control Clock signal, CCLK.

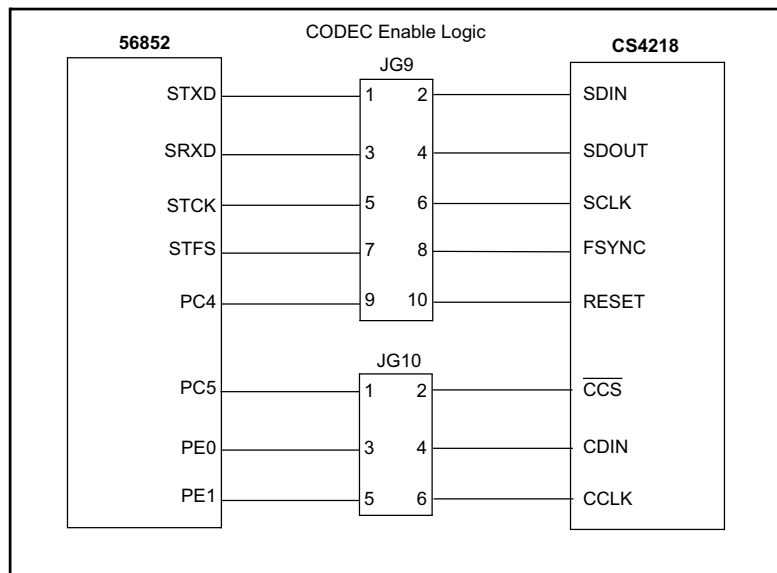

Figure 2-12. CS4218 Stereo Audio Codec

Table 2-9. SSI Port Connector Description

JG9			
Pin #	Controller Signal	Pin #	Codec Signal
1	STXD	2	SDIN
3	SRXD	4	SDOUT
5	STCK	6	SCLK
7	STFS	8	FSYNC
9	PC4	10	RESET

Table 2-10. GPIO Port Connector Description

JG10			
Pin #	Controller Signal	Pin #	Codec Signal
1	PC5	2	$\overline{\text{CCS}}$
3	PE0	4	CDIN
5	PE1	6	CCLK

2.13 Daughter Card Connectors

The EVM board contains two daughter card expansion connectors. One connector, J1, contains the controller's external memory bus signals. The other connector, J2, contains the controller's peripheral port signals.

2.13.1 Memory Daughter Card Expansion Connector

The controller's external memory bus signals are connected to the Memory Daughter Card Expansion connector, J1. [Table 2-11](#) shows the port signal-to-pin assignments.

Table 2-11. Memory Daughter Card Connector Description

J1			
Pin #	Signal	Pin #	Signal
1	A10	2	A11
3	A9	4	$\overline{\text{CS1}}$
5	A8	6	A15
7	A7	8	A14
9	A20	10	A19
11	$\overline{\text{WR}}$	12	A13
13	D0	14	A12
15	D1	16	D8
17	D2	18	D9

Table 2-11. Memory Daughter Card Connector Description (Continued)

J1			
Pin #	Signal	Pin #	Signal
19	GND	20	GND
21	D3	22	D10
23	D4	24	D11
25	D5	26	D12
27	D6	28	D13
29	A18	30	A17
31	D7	32	D14
33	$\overline{CS0}$	34	D15
35	A0	36	\overline{RD}
37	A1	38	A6
39	A16	40	GND
41	A2	42	A5
43	A3	44	A4
45	A19/ $\overline{CS3}$	46	$\overline{CS2}$
47	+3.3V	48	+3.3V
49	GND	50	GND
51	+5.0V		

2.13.2 Peripheral Daughter Card Expansion Connector

The controller's peripheral port signals are connected to the Peripheral Daughter Card Expansion connector, J2. [Table 2-12](#) shows the port signal-to-pin assignments.

Table 2-12. Peripheral Daughter Card Connector Description

J2			
Pin #	Signal	Pin #	Signal
1	$\overline{\text{CS0/PA0}}$	2	$\overline{\text{CS1/PA1}}$
3	A20/CLKO	4	$\overline{\text{CS2/PA2}}$
5	A17/TIO0	6	A18/TIO1
7	GND	8	GND
9	GND	10	GND
11	GND	12	GND
13	GND	14	GND
15	SRXD	16	$\overline{\text{CS0/PA0}}$
17	MOSI/SRFS	18	$\overline{\text{CS1/PA1}}$
19	SCK/SCLK	20	$\overline{\text{CS2/PA2}}$
21	GND	22	GND
23	MOSI	24	GND
25	MISO	26	GND
27	GND	28	GND
29	$\overline{\text{SS}}$	30	GND
31	MISO/SRCK	32	GND
33	$\overline{\text{SS/STFS}}$	34	GND
35	$\overline{\text{RESET}}$	36	GND
37	GND	38	GND
39	STXD	40	GND
41	SCK/STCK	42	GND

Table 2-12. Peripheral Daughter Card Connector Description (Continued)

J2			
Pin #	Signal	Pin #	Signal
43	$\overline{\text{IRQB}}$	44	RXD
45	$\overline{\text{IRQA}}$	46	TXD
47	+3.3V	48	+3.3V
49	GND	50	GND
51	+5.0V		

2.14 Test Points

The 56852EVM board has a total of seven test points. Three digital GND test points are located in corners of the board. The +5.0VA and AGND test points are located in the analog corner of the board. The +1.8V and +3.3V test points are located in the power supply section of the board.

Appendix A

DSP56852EVM Schematics

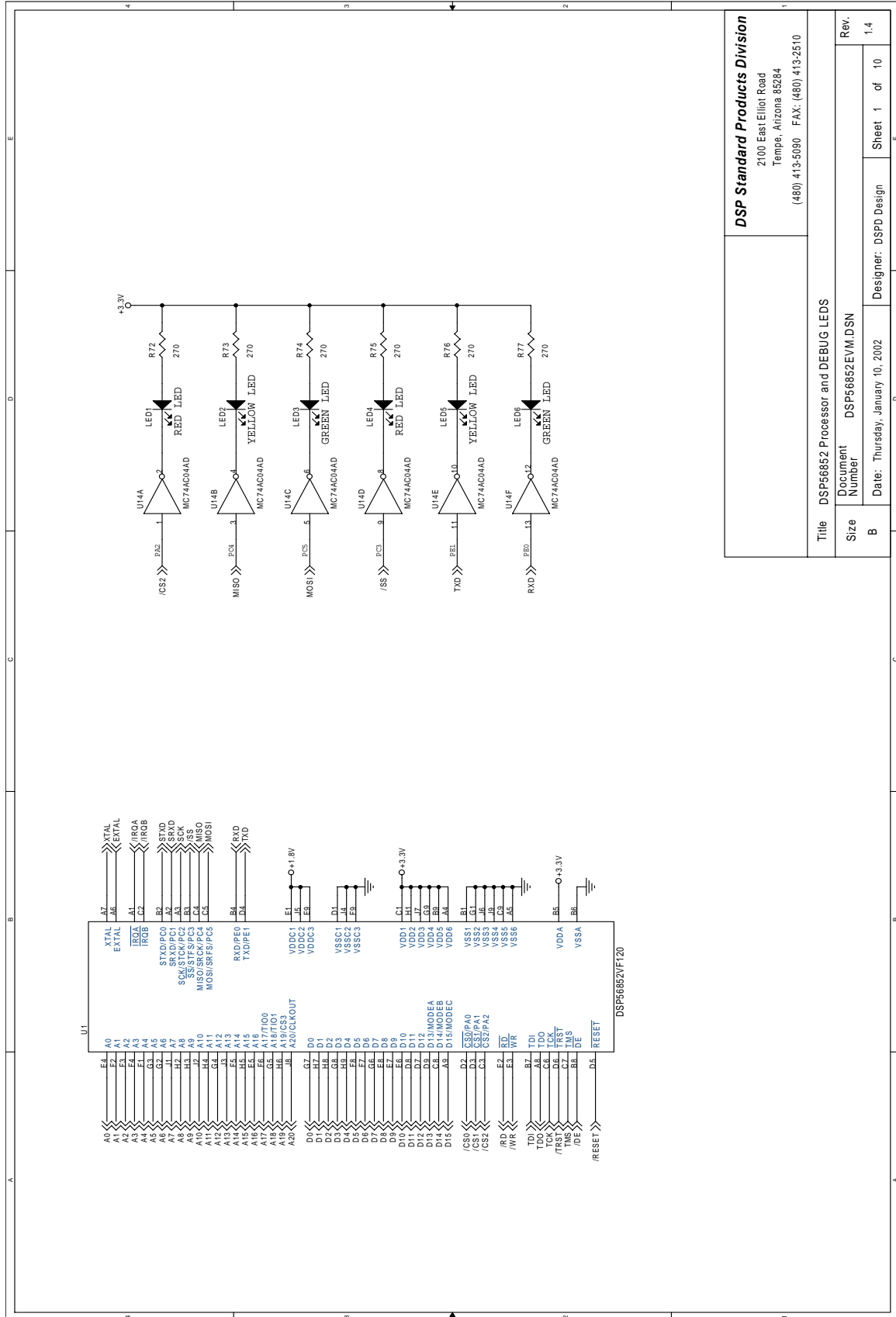

DSP Standard Products Division 2100 East Elliot Road Tempe, Arizona 85284 (480) 413-5090 FAX: (480) 413-2510	
Title DSP56852 Processor and DEBUG LEDs	
Document Number DSP56852EVM.DSN	Rev. 1.4
Date: Thursday, January 10, 2002	Designer: DSPD Design Sheet 1 of 10

Figure A-1. 56852 Processor and Debug LEDs

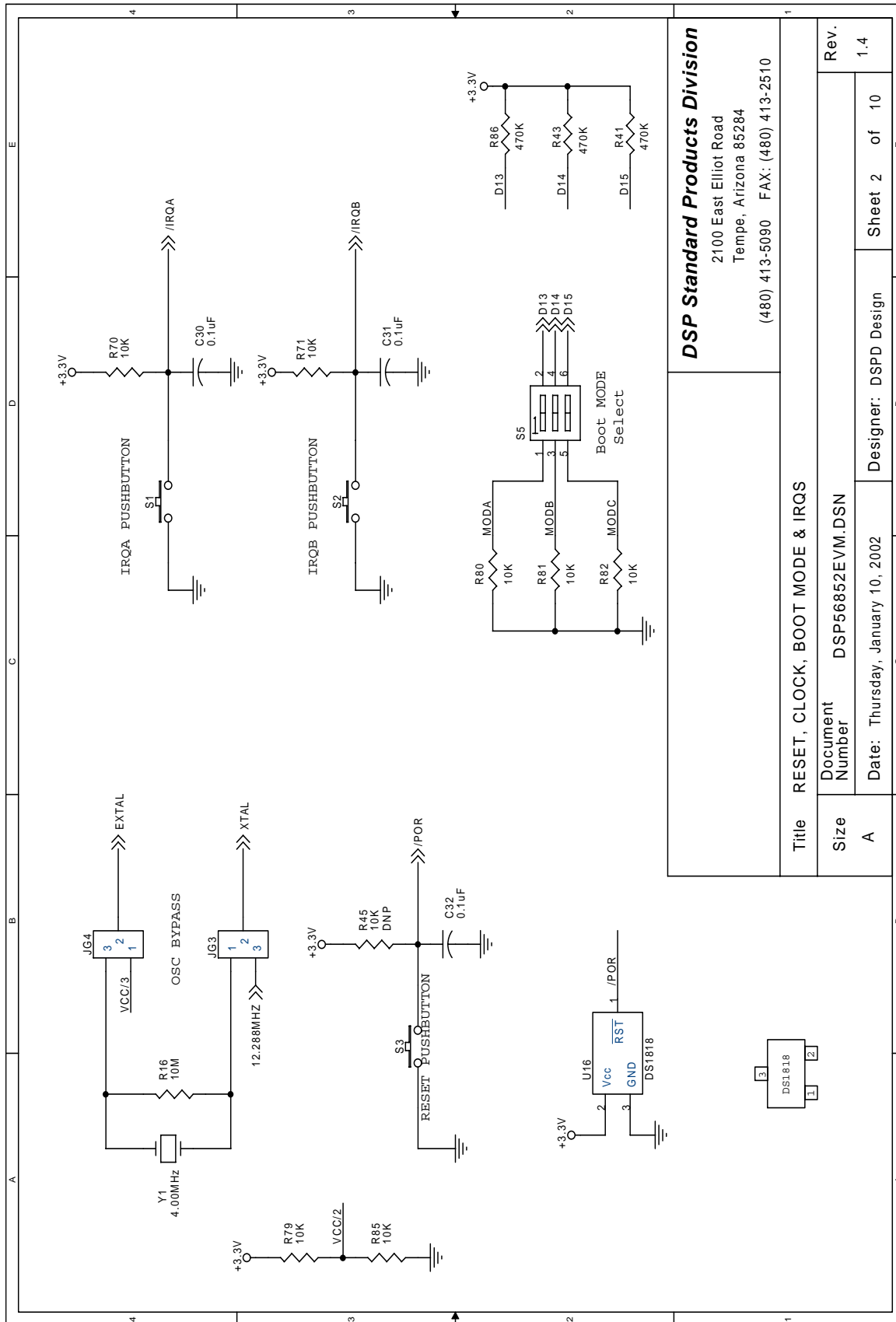

DSP56852EVM Schematics, Rev. 3

DSP Standard Products Division 2100 East Elliot Road Tempe, Arizona 85284 (480) 413-5090 FAX: (480) 413-2510		Title RESET, CLOCK, BOOT MODE & IRQS	
		Size A	Document Number DSP56852EVM.DSN
Date: Thursday, January 10, 2002		Designer: DSPD Design	Sheet 2 of 10
Rev. 1.4			

Figure A-2. Reset, Clock, Boot Mode & IRQs

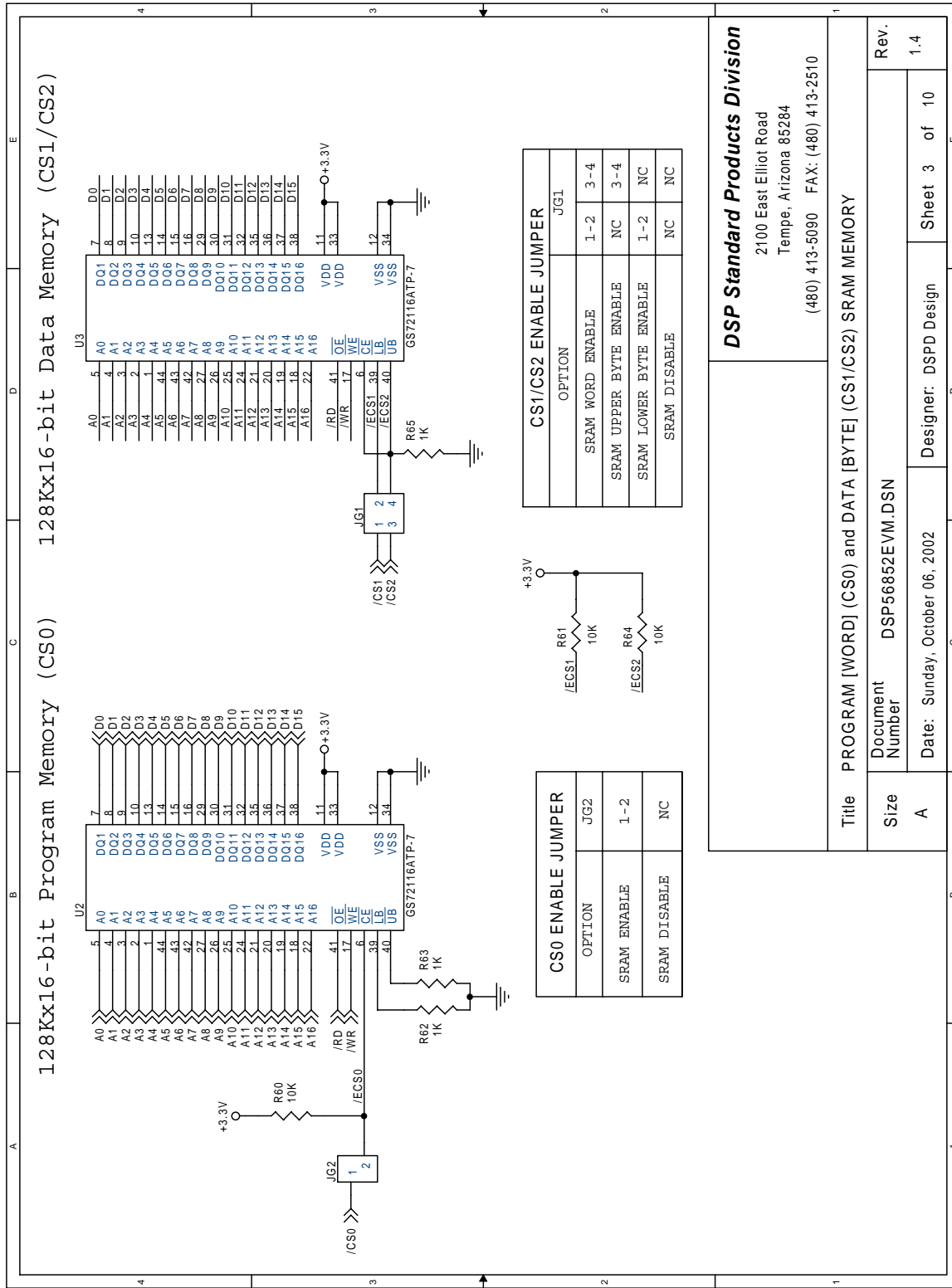
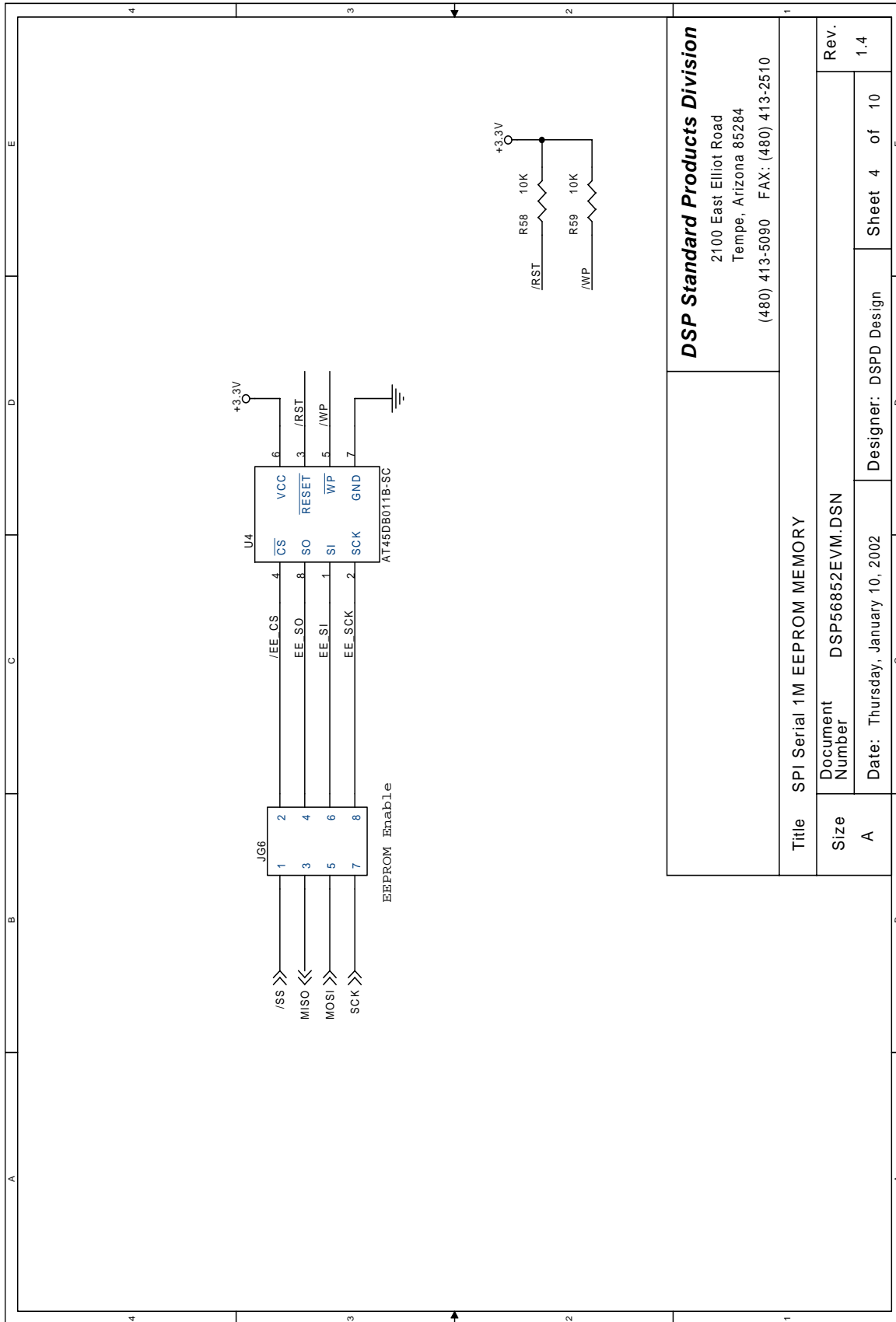
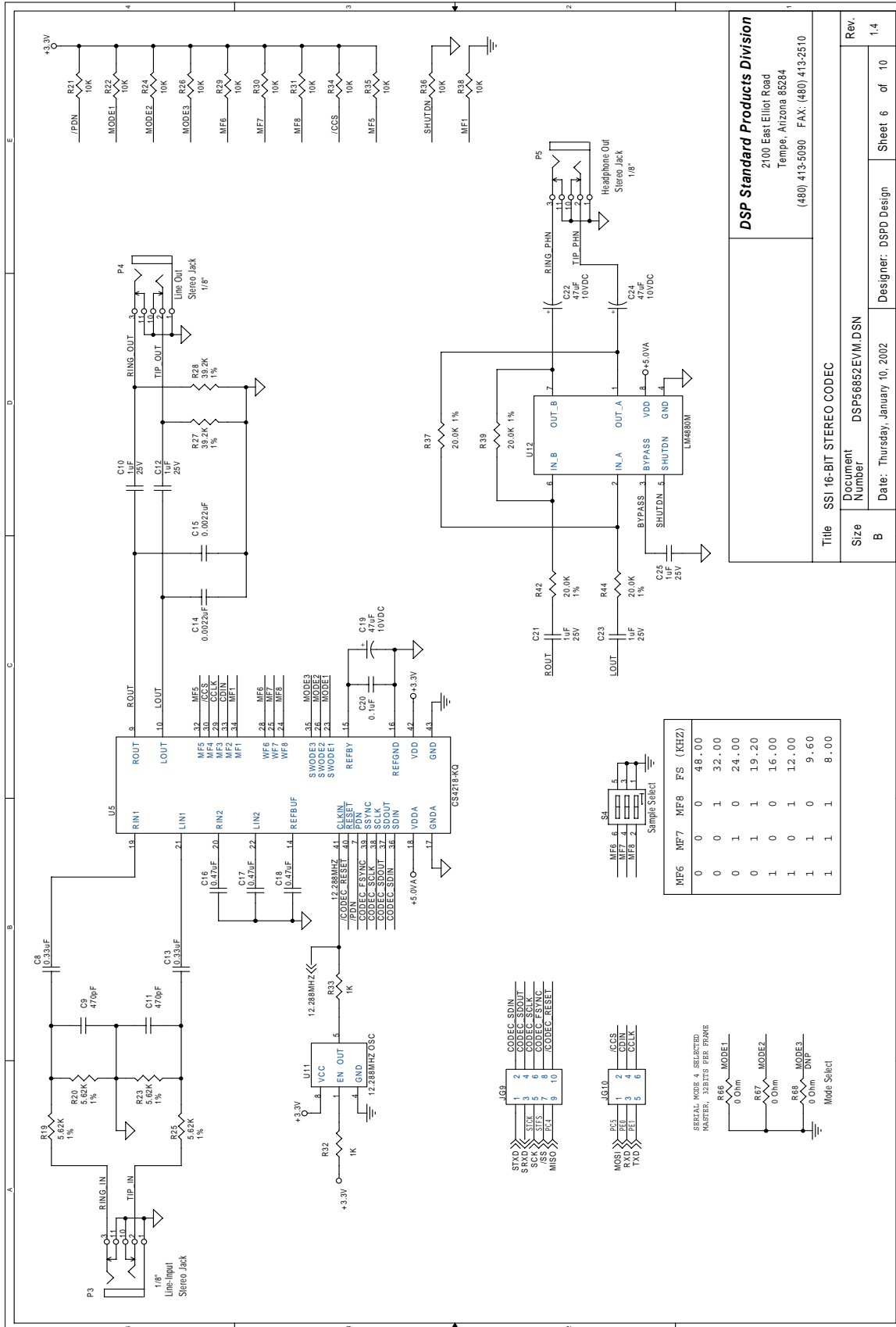

Figure A-3. Program [Word] (CS0) & Data [Byte] (CS1/CS2) SRAM Memory



DSP Standard Products Division 2100 East Elliot Road Tempe, Arizona 85284 (480) 413-5090 FAX: (480) 413-2510	
Title SPI Serial 1M EEPROM MEMORY	
Size	Document Number DSP56852EVM.DSN
A	Date: Thursday, January 10, 2002
Designer: DSPD Design	
Sheet 4 of 10	Rev. 1.4

Figure A-4. SPI Serial 1M-bit Serial EEPROM Memory



DSP Standard Products Division
 2100 East Elliot Road
 Tempe, Arizona 85284
 (480) 413-5090 FAX: (480) 413-2510

Title		SSI 16-BIT STEREO CODEC	
Document Number	DSP56852EVM.DSN		
Size	B		
Date:	Thursday, January 10, 2002	Designer:	DSPD Design
Sheet	6	of	10
Rev.	1.4		

MF6	MF7	MF8	FS	(KHZ)
0	0	0	0	48.00
0	0	1	0	32.00
0	1	0	0	24.00
0	1	1	0	19.20
1	0	0	0	16.00
1	0	1	0	12.00
1	1	0	0	9.60
1	1	1	0	8.00

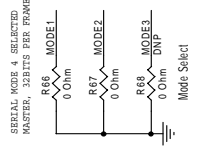
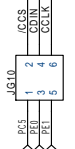
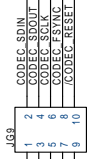
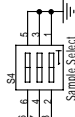

DSP56852EVM Schematics, Rev. 3

Parallel JTAG Interface

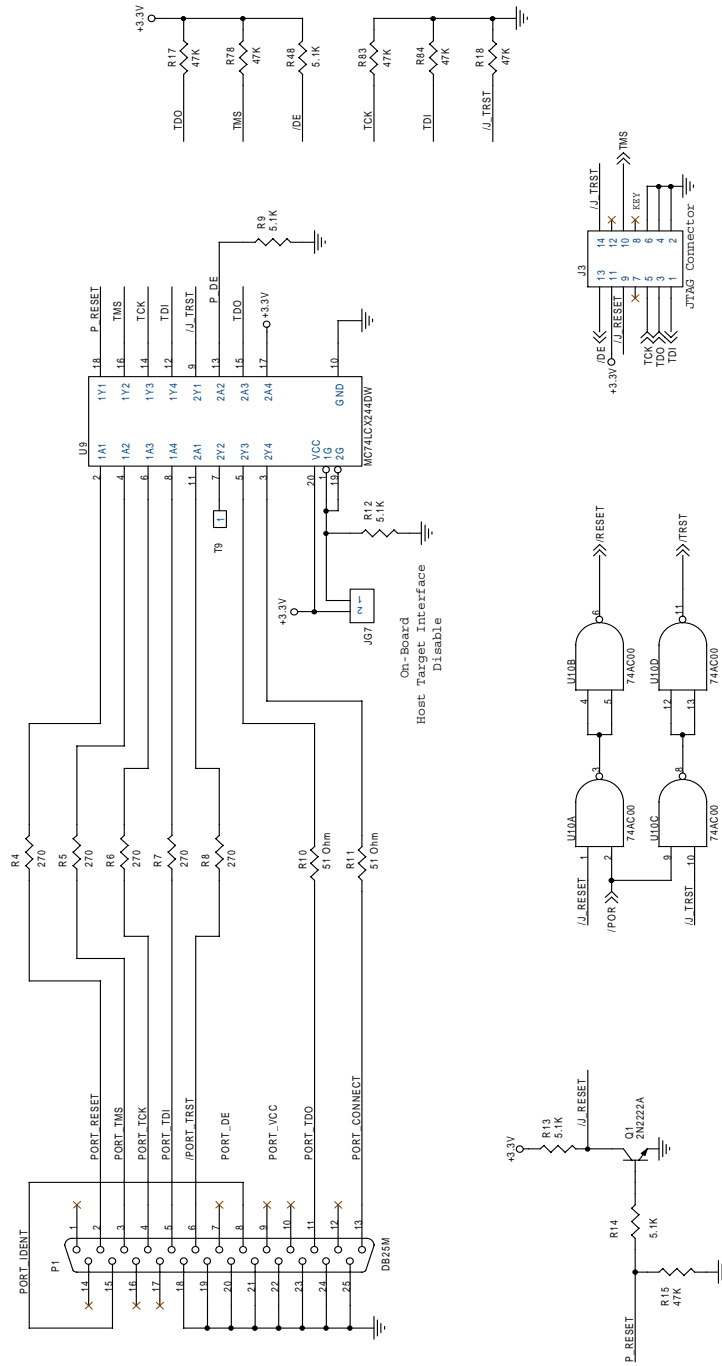

DSP Standard Products Division 2100 East Elliot Road Tempe, Arizona 85284 (480) 413-5090 FAX: (480) 413-2510	
Title: PARALLEL JTAG HOST TARGET INTERFACE AND JTAG CONNECTOR	
Document Number: DSP56852EVM.DSN	Rev. 1.4
Date: Thursday, January 10, 2002	Designer: DSPD Design
Sheet 7 of 10	Sheet 7 of 10

Figure A-7. Parallel JTAG Host Target Interface and JTAG Connector

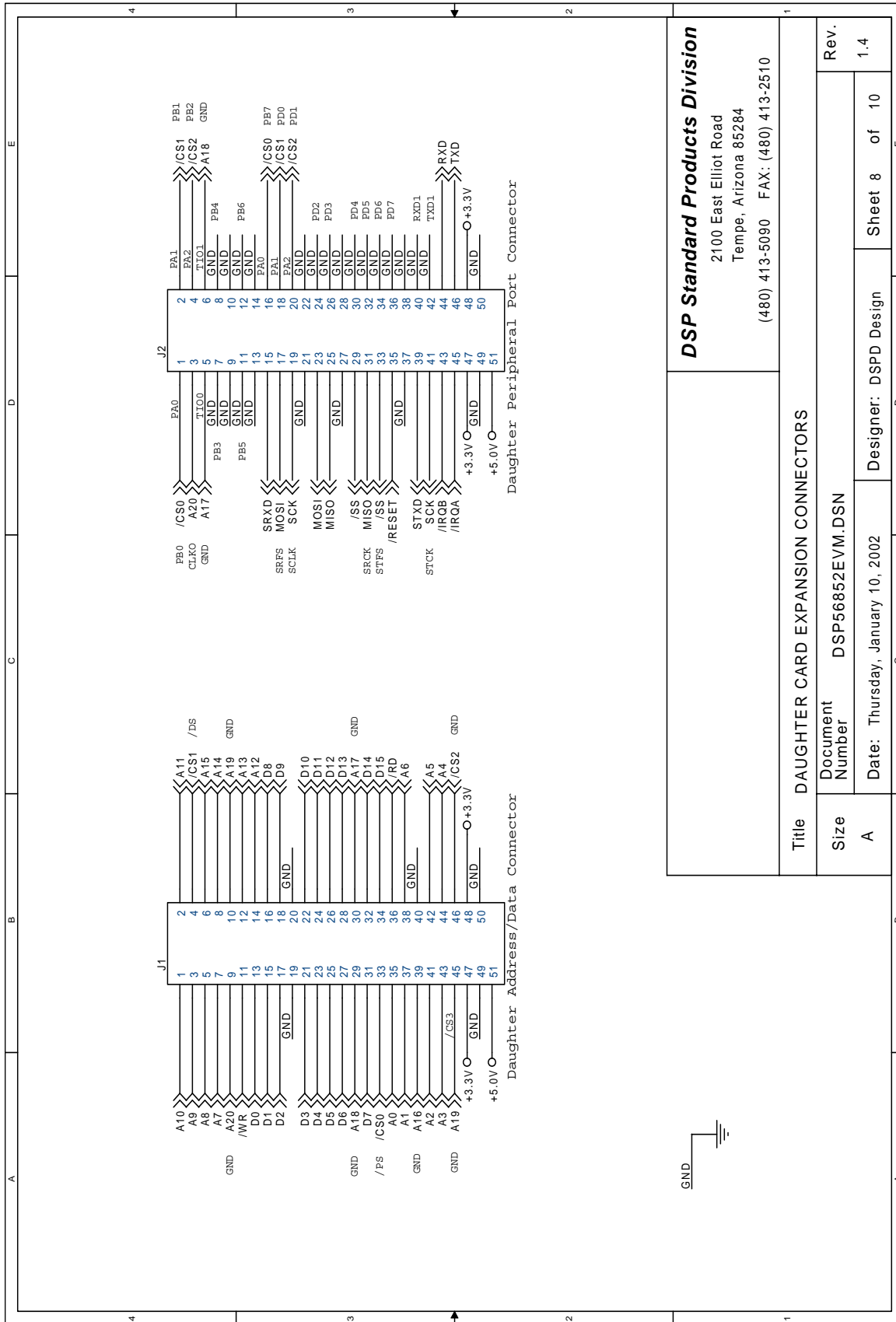

DSP56852EVM Schematics, Rev. 3

Figure A-8. Daughter Card Expansion Connectors



Appendix B

DSP56852EVM Bill of Material

Qty	Description	Ref. Designators	Vendor Part #s
Integrated Circuits			
1	DSP56852	U1	Freescale, DSP56852VF120
2	GS72116	U2, U3	GSI, GS72116ATP-7
1	AT45DB011	U4	Atmel, AT45DB011B-SC
1	CS4218	U5	Crystal Semiconductor, CS4218-KQ
1	MAX3245	U6	Maxim, MAX3245EEAI
1	+3.3V Voltage Regulator	U7	ON Semiconductor, MC33269DT-3.3
1	+1.8V Voltage Regulator	U8	ON Semiconductor, MC33269DT-ADJ
1	74LCX244	U9	ON Semiconductor, MC74LCX244ADW
1	74AC00	U10	Fairchild, 74AC00SC
1	12.288MHz OSC	U11	Epson, SG-531P-12.288MC
1	LM4880	U12	National Semiconductor, LM4880M
1	+5.0V Voltage Regulator	U13	ON Semiconductor, MC33269DT-5
1	74AC04	U14	ON Semiconductor, MC74AC04AD
1	DS1818	U16	Dallas Semiconductor, DS1818
Resistors			
1	243 Ω , 1%	R1	SMEC, RC73L243OHMFT
1	107 Ω , 1%	R2	SMEC, RC73L107OHMFT
12	270 Ω	R3 - R8, R72 - R77	SMEC, RC73L2A270OHMJT
2	51 Ω	R10, R11	SMEC, RC73L2A51OHMJT

Qty	Description	Ref. Designators	Vendor Part #s
Resistors (Continued)			
5	5.1K Ω	R9, R12 - R14, R48	SMEC, RC73L2A5.1KOHMJT
6	47K Ω	R15, R17, R18, R78, R83, R84	SMEC, RC73L2A47KOHMJT
1	10M Ω	R16	SMEC, RC73L2A10MOHMJT
4	5.62K Ω , 1%	R19, R20, R23, R25	SMEC, RC73L2A5.62KOHMFT
23	10K Ω	R21, R22, R24, R26, R29 - R31, R34-R36, R38, R58-R61, R64, R70, R71, R79 - R82, R85	SMEC, RC73L2A10KOHMJT
2	39.2K Ω , 1%	R27, R28	SMEC, RC73L2A39.2KOHMFT
13	1K Ω	R32, R33, R50-R57, R62, R63, R65	SMEC, RC73L2A1KOHMJT
4	20.0K Ω , 1%	R37, R39, R42, R44	SMEC, RC73L20.0KOHMFT
3	470K Ω	R41, R43, R86	SMEC, RC73L2A470KOHMJT
0	10K Ω	R45	SMEC, RC73L2A10KOHMJT
2	0 Ω	R66, R67	SMEC, RC73JP2A
0	0 Ω	R68	SMEC, RC73JP2A
Inductors			
4	1.0mH FERRITE BEAD	L1 - L4	Panasonic, EXC-ELSA35V
LEDs			
2	Red LED	LED1, LED4	Hewlett-Packard, HSMS-C650
2	Yellow LED	LED2, LED5	Hewlett-Packard, HSMY-C650
3	Green LED	LED3, LED6, LED7	Hewlett-Packard, HSMG-C650
Diode			
1	S2B-FM401	D1	Vishay, DL4001DICT
1	+50V 1A BRIDGE RECT	D2	DIODES, DF02S

Qty	Description	Ref. Designators	Vendor Part #s
Capacitors			
1	470 μ F, +16V DC	C1	ELMA, RV-16V471MH10R
21	0.1 μ F	C2, C4, C6, C20, C30 - C32, C34, C36, C38, C40, C42, C44, C46, C48, C50, C51, C53, C54, C56, C58	SMEC, MCCE104K2NR-T1
6	47 μ F, +16V DC	C3, C5, C7, C19, C22, C24	ELMA, RV2-16V470M-R
2	0.33 μ F	C8, C13	SMEC, MCCE334K3NR-T1
2	470pF	C9, C11	SMEC, MCCE471J2NO-T1
9	1.0 μ F, +25V DC	C10, C12, C21, C23, C25 - C29	SMEC, MCCE105K3NR-T1
2	0.0022 μ F	C14, C15	SMEC, MCCE222K2NR-T1
3	0.47 μ F	C16 - C18	SMEC, MCCE474K3NR-T1
12	0.01 μ F	C33, C35, C37, C39, C41, C43, C45, C47, C49, C52, C55, C57	SMEC, MCCE103K2NR-T1
Jumpers			
3	1 \times 2, 2mm Header	JG2, JG7, JG8	SAMTEC, TMM-102-02-S-S
2	3 \times 1, 2mm Header	JG3, JG4	SAMTEC, TMM-103-02-S-S
1	4 \times 2, 2mm Header	JG6	SAMTEC, TMM-104-02-S-D
2	2 \times 2, 2mm Header	JG1, JG5	SAMTEC, TMM-102-02-S-D
1	5 \times 2, 2mm Header	JG9	SAMTEC, TMM-105-02-S-D
1	3 \times 2, 2mm Header	JG10	SAMTEC, TMM-103-02-S-D
Test Points			
4	Black Test Point	TP1, TP3, TP6, TP7	Keystone, 5001
1	Red Test Point	TP2	Keystone, 5000
1	White Test Point	TP4	Keystone, 5002
1	Yellow Test Point	TP5	Keystone, 5004
Crystals			
1	4.00MHz Crystal	Y1	CTS, ATS04ASM-T

Qty	Description	Ref. Designators	Vendor Part #s
Connectors			
1	DB25M Connector	P1	AMPHENOL, 617-C025P-AJ121
1	2.1mm coax Power Connector	P2	Switchcraft, RAPC-722
3	1/8" Stereo Jack	P3 - P5	Switchcraft, 35RAPC4BHN2
1	DE9S Connector	P6	AMPHENOL, 617-C009S-AJ120
2	51-Pin HD Connector	J1, J2	BERG, 91930-21151
1	7 x 2 Bergstick	J3	SAMTEC, TSW-107-07-S-D
1	2-Pin Terminal Block	TB1	On-Shore Technology, ED500/2DS
Switches			
3	SPST Pushbutton	S1 - S3	Panasonic, EVQ-PAD05R
2	3-Position DIP SW	S4, S5	CTS, 209-3LPST
Transistors			
1	2N2222A	Q1	ZETEX, FMMT2222ACT
Miscellaneous			
19	2mm Shunt	SH1 - SH19	Samtec, 2SN-BK-G
4	Rubber Feet	RF1 - RF4	3M, SJ5018BLKC

INDEX

C

Clock Source [2-7](#)
Codec [Preface-ix](#)
Codec sample rate selector [2-2](#)
Connecting the DSP56852EVM Cables [1-4](#)
Connectors
 Memory Daughter Card Expansion [2-19](#)

D

Daughter Card Connectors [2-19](#)
Daughter Card Expansion interface [2-1](#)
Debugging [2-8](#)
DSP [Preface-ix](#)
DSP56852EVM
 1 M-bit Serial EEPROM/Data FLASH [2-1](#)
 12.0V DC power supply [2-15](#)
 128Kx16-bit of data memory (U3) [2-1](#)
 128Kx16-bit of memory (U2) [2-1](#)
 16-bit 1.8V/3.3V Digital Signal Processor [2-1](#)
 16-bit stereo codec interface [2-1](#)
 4.00MHz crystal oscillator [2-1](#)
 external oscillator frequency input [2-1](#)
 FSRAM [2-1](#)
 ISSI compatible peripheral [2-2](#)
 JTAG port interface [2-1](#)
 On-board power regulation [2-2](#)
 Parallel JTAG Host Target Interface [2-1](#)
 real-time debugging [2-8](#)
 RS-232 interface [2-1](#)
 SCI compatible peripheral [2-2](#)
 test points [2-22](#)

E

EEPROM [Preface-ix](#)
EOnCE [Preface-ix](#)
EVM [Preface-ix](#)

F

FSRAM [2-3](#)

G

GPIO [Preface-ix, 2-2](#)

H

Host Parallel Interface Connector [2-9](#)
Host Target Interface [2-9](#)

I

IC [Preface-ix](#)
ISSI [Preface-ix](#)

J

JTAG [Preface-ix, 1-1, 2-1](#)
 connector [2-10](#)
Jumper Group [1-3](#)
 JG1 [1-3](#)
 JG10 [1-3](#)
 JG2 [1-3](#)
 JG3 [1-3](#)
 JG4 [1-3](#)
 JG5 [1-3](#)
 JG6 [1-3](#)
 JG7 [1-3](#)
 JG8 [1-3](#)
 JG9 [1-3](#)

L

LED [Preface-ix](#)

M

MBGA [Preface-ix](#)
MPIO [Preface-ix](#)

O

Operating Mode [2-8](#)

P

PCB [Preface-ix](#)
PLL [Preface-ix](#)

R

RAM [Preface-ix](#)

ROM [Preface-ix](#)

RS-232

interface [2-1](#), [2-6](#)

level converter [2-6](#)

schematic diagram [2-6](#)

RS-232 Serial Communications [2-6](#)

S

SCI [Preface-ix](#)

SPI [Preface-x](#), [2-2](#)

SRAM [Preface-x](#)

external data [2-1](#)

external program [2-1](#)

SSI [Preface-x](#)

stereo 16-bit codec interface [2-1](#)

Stereo headphone interface [2-1](#)

W

WS [Preface-x](#)

How to Reach Us:

Home Page:

www.freescale.com

E-mail:

support@freescale.com

USA/Europe or Locations Not Listed:

Freescale Semiconductor
Technical Information Center, CH370
1300 N. Alma School Road
Chandler, Arizona 85224
+1-800-521-6274 or +1-480-768-2130
support@freescale.com

Europe, Middle East, and Africa:

Freescale Halbleiter Deutschland GmbH
Technical Information Center
Schatzbogen 7
81829 Muenchen, Germany
+44 1296 380 456 (English)
+46 8 52200080 (English)
+49 89 92103 559 (German)
+33 1 69 35 48 48 (French)
support@freescale.com

Japan:

Freescale Semiconductor Japan Ltd.
Headquarters
ARCO Tower 15F
1-8-1, Shimo-Meguro, Meguro-ku,
Tokyo 153-0064, Japan
0120 191014 or +81 3 5437 9125
support.japan@freescale.com

Asia/Pacific:

Freescale Semiconductor Hong Kong Ltd.
Technical Information Center
2 Dai King Street
Tai Po Industrial Estate
Tai Po, N.T., Hong Kong
+800 2666 8080
support.asia@freescale.com

For Literature Requests Only:

Freescale Semiconductor Literature Distribution Center
P.O. Box 5405
Denver, Colorado 80217
1-800-441-2447 or 303-675-2140
Fax: 303-675-2150
LDCForFreescaleSemiconductor@hibbertgroup.com

Information in this document is provided solely to enable system and software implementers to use Freescale Semiconductor products. There are no express or implied copyright licenses granted hereunder to design or fabricate any integrated circuits or integrated circuits based on the information in this document.

Freescale Semiconductor reserves the right to make changes without further notice to any products herein. Freescale Semiconductor makes no warranty, representation or guarantee regarding the suitability of its products for any particular purpose, nor does Freescale Semiconductor assume any liability arising out of the application or use of any product or circuit, and specifically disclaims any and all liability, including without limitation consequential or incidental damages. "Typical" parameters that may be provided in Freescale Semiconductor data sheets and/or specifications can and do vary in different applications and actual performance may vary over time. All operating parameters, including "Typicals", must be validated for each customer application by customer's technical experts. Freescale Semiconductor does not convey any license under its patent rights nor the rights of others. Freescale Semiconductor products are not designed, intended, or authorized for use as components in systems intended for surgical implant into the body, or other applications intended to support or sustain life, or for any other application in which the failure of the Freescale Semiconductor product could create a situation where personal injury or death may occur. Should Buyer purchase or use Freescale Semiconductor products for any such unintended or unauthorized application, Buyer shall indemnify and hold Freescale Semiconductor and its officers, employees, subsidiaries, affiliates, and distributors harmless against all claims, costs, damages, and expenses, and reasonable attorney fees arising out of, directly or indirectly, any claim of personal injury or death associated with such unintended or unauthorized use, even if such claim alleges that Freescale Semiconductor was negligent regarding the design or manufacture of the part.



Freescale™ and the Freescale logo are trademarks of Freescale Semiconductor, Inc. All other product or service names are the property of their respective owners. This product incorporates SuperFlash® technology licensed from SST.

© Freescale Semiconductor, Inc. 2005. All rights reserved.

DSP56827EVMUM
Rev. 3
07/2005