

Focus

User Manual



Copyright

Code: 51774-IMG rev 8 Date: 21 November 2008
Document code: 51774-IMG1TPH-1 rev 8

Copyright © 11/2008 by PaloDEx Group Oy.
All rights reserved.

Documentation, trademark and the software are copyrighted with all rights reserved. Under the copyright laws the documentation may not be copied, photocopied, reproduced, translated, or reduced to any electronic medium or machine readable form in whole or part, without the prior written permission of Instrumentarium Dental.

The original language of this manual is English.

Instrumentarium Dental reserves the right to make changes in specification and features shown herein, or discontinue the product described at any time without notice or obligation. Contact your Instrumentarium Dental representative for the most current information.

**Manufactured by**

Instrumentarium Dental
Nahkelantie 160 (P.O. Box 20)
FI-04300 Tuusula
FINLAND
Tel. +358 45 7882 2000
Fax. +358 9 851 4048

For service, contact your local distributor.

Table of Contents

1	Introduction	1
1.1	General	1
1.2	Markings and graphics symbols	2
1.3	Type and version	3
1.4	Labels on FOCUS	4
1.5	Configurations	5
1.6	Radiation protection guidelines	7
1.7	Manufacturer's liability	8
1.8	Disposal	9
2	Equipment controls	11
2.1	Main parts	11
2.2	Symbols on remote control	12
2.3	Focus with SmartBox option	13
2.4	Unit mount model Focus	14
3	Preparations for the exposure	17
3.1	Precautionary actions for safe use	17
3.2	Switching the power on	17
3.3	Selecting the cone	17
3.4	Selecting the exposure parameters	18
3.5	Positioning the patient	19
3.6	AEC Automatic Exposure Control	20
3.7	Focus with SmartBox	21
3.8	Making an exposure	21
3.9	Monitoring of dose levels	21
4	Program mode	23
4.1	Programmable anatomical time settings	24
5	Error messages	25
6	Maintenance	27
6.1	Cleaning	27
6.2	Disinfecting	27
6.3	Periodic maintenance	28
7	Technical data	29
7.1	Technical specifications	29
8	User's statement	33
9	Recommended digital/film exposure times	39



1 Introduction

1.1 General

FOCUS is a microprocessor controlled intraoral x-ray unit with a HF DC generator. FOCUS produces high quality dental images with film or digital sensors.

The well-balanced support arm is easy to move and very stable, keeping the unit motionless during the exposure. FOCUS' proprietary design has the VHF DC generator built into the horizontal part of the units support arm enabling greater reliability and ease of installation and service.

The VHF DC generator keeps the patient dose to the absolute minimum. The user friendly remote control features pre-programmed anatomical time settings making the exposure selection quick and effortless. These settings can be reprogrammed if needed.

Other selections include 60 or 70 kV, exposure times between 0.02 and 3.2 seconds, pediatric or adult modes, and film and digital modes. Exposures can be made directly from the remote control panel or with the optional remote exposure button. With a choice of arm lengths and ability to mechanically mount the unit in different configurations, the FOCUS is a fully customizable x-ray system.

As the manufacturer we strongly recommend that you read this manual before placing the unit into service.

NOTE! *FOCUS must be installed according to the FOCUS Installation manual by a qualified technician. Only trained personnel should be allowed to operate FOCUS.*

1.2 Markings and graphics symbols

The following symbols are used in FOCUS



Focal spot

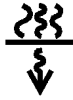

Total filtration



Radiographic control



Protective earth (ground)



Type B equipment



Dangerous voltage



ON (Power)



OFF (Power)



Attention, consult accompanying documents



CE-marked according to the Medical Device Directive 93/42/EEC.



X-ray source assembly: emitting



Radiation warning



This symbol indicates that the waste of electrical and electronic equipment must not be disposed as unsorted municipal waste and must be collected separately. Please contact an authorized representative of the manufacturer for information concerning the decommissioning of your equipment.

1.3 Type and version

The type and version of FOCUS is defined in the main label of the unit located on the under side of the horizontal arm and in the tube / HV generator housing assembly label on the tube head. The unit is class I, type B and with IP-20 protection.

The focal length is defined in the cone label in addition to type and version.

The software version is momentarily displayed on remote control display after switching the unit on.

1.4 Labels on FOCUS

Type Focus
 Ser No:
 Made in: Finland

Type Focus
 Ser No:
 Made in: Finland

Type Focus
 Ser No:
 Made in: Finland

Type Focus
 Ser No:
 Made in: Finland

Type Focus
 Ser No:
 Made in: Finland

Made by
 Instrumentarium Imaging
 P.O. Box 20, FIN-04301 TUUSULA, Finland

Made by
 Instrumentarium Imaging
 P.O. Box 20, FIN-04301 TUUSULA, Finland

Made by
 Instrumentarium Imaging
 P.O. Box 20, FIN-04301 TUUSULA, Finland

This model complies with IEC 60601-1
 2 (3rd Edition) and applicable parts of IEC 60601-1-2
 Edition 03-06 (revised 2007) (3rd Edition)

The product complies with IEC 60601-1
 2 (3rd Edition) and applicable parts of IEC 60601-1-2
 Edition 03-06 (revised 2007) (3rd Edition)

The product complies with IEC 60601-1
 2 (3rd Edition) and applicable parts of IEC 60601-1-2
 Edition 03-06 (revised 2007) (3rd Edition)

The product complies with IEC 60601-1
 2 (3rd Edition) and applicable parts of IEC 60601-1-2
 Edition 03-06 (revised 2007) (3rd Edition)

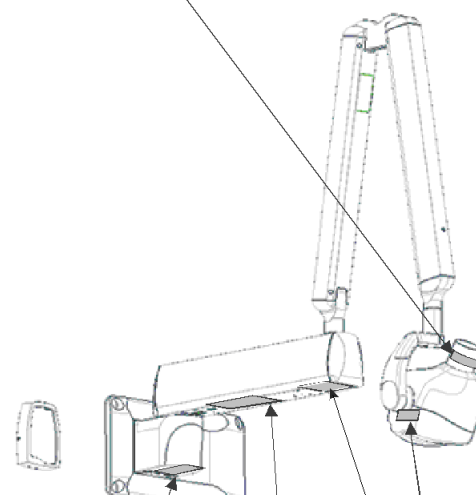

FUSES/FUSIBLES
 230V~6.25 AT
 115V~6.25 AT

WARNING:
 For continued protection against risk of fire,
 replace only with the same type and rating of fuses.

ATTENTION:
 Pour assurer une protection continue contre
 le risque d'incendie, utilisez uniquement un
 fusible de rechange de même type et de
 même caractéristique nominale.

WARNING: ⚡ ⚠
 Voltages inside this cover can be deadly.
 Peak voltage level normally exceeds 300V.

ATTENTION:
 Les tensions à l'intérieur peuvent être mortelles.
 Tensions supérieures à 300V.

TUBEMAY GENERATOR HOUSING ASSEMBLY
 TYPE: Focus
 Ser No:
 Tube type: D-0711 8B
 Tube No:
 Date of manuf.:
 0.7 mm
 (IEC336:1993)
 70 W
 maximum 940 mAsh
 Total Filtration $\frac{2}{3}$
 2.0 mm Al 70kV

This product complies with IEC 60601-1
 2 (3rd Edition) and applicable parts of IEC 60601-1-2
 Edition 03-06 (revised 2007) (3rd Edition)

Manufactured in Finland
 by Instrumentarium Corp.
 Imaging division
 P.O. Box 20, FIN-04301
 TUUSULA

TYPE: Focus
 Date of manufacture:
 3.55 A 230 V~ 2000 Hz 816 YA
 7.63 A 115 V~ 2000 Hz 877 YA

IEC 60601-1 ⚡ ⚠ IP-20

X-ray equipment with radiation protection
 in accordance with IEC 60601-1-3:1994

This product complies with IEC 60601-1-3:1994
 Edition 03-06 (revised 2007) (3rd Edition)

Made by
 Instrumentarium Imaging
 P.O. Box 20, FIN-04301 TUUSULA, Finland

CE 0537

1.5 Configurations

WARNING! USE LIMITATION : *External components: The use of accessories, transducers, and cables other than those specified may result in degraded ELECTROMAGNETIC COMPATIBILITY of the EQUIPMENT and/or SYSTEM.*

WARNING! *If you suspect any electro-magnetical interference affecting or caused by the unit, call service. Portable and mobile RF communications equipment can interfere with operation of the medical electrical equipment.*

Focus is delivered with one of the following configuration:

FOCUS BASIC SYSTEMS:
FOCUS x-ray machine with short reach 176 cm/69.2", 115 V,
FOCUS x-ray machine with long reach 191 cm/75.1", 115 V
FOCUS x-ray machine with extra long reach 216 cm/84.9", 115 V
FOCUS x-ray machine with short reach 176 cm/69.2", 230 V
FOCUS x-ray machine with long reach 191 cm/75.1", 230 V
FOCUS x-ray machine with extra long reach 216 cm/84.9", 230 V

Each Focus basic system is equipped with remote control with 32.8 feet (10m) 8 wire cable with RJ-45 plugs.

One chosen item from each module below is delivered with the basic unit:

TO BE CHOSEN FOR BASIC SYSTEM:
Cones
Short cone round
Short cone rectangular
Long cone round
Long cone rectangular
Short full metal rectangular cone
Long full metal rectangular cone
Short cone rectangular for Germany

Wall mount plates
Wall mount plate for single stud
Wall mount plate for 16" center studs
Manual language
English
Italian
German
French

Following accessories are approved items, and they can be ordered separately.

ACCESSORIES
Short cone round
Short cone rectangular
Long cone round
Long cone rectangular
Long full metal rectangular cone
Short full metal rectangular cone
Short cone rectangular for Germany
Short horizontal arm 500 mm / 19.7 in
Long horizontal arm 650 mm / 25.6 in
Extra long horizontal arm 900 mm / 35.4 in
Additional remote control (one Focus unit can be installed with two)
Remote exposure button (one Focus unit can be installed with two)
Wall mount plate for single stud.
Wall mount plate for 16" center studs.

NOTE! *To maintain safe and correct operation of FOCUS, only the approved accessories should be used. All the standard and optional items and approved accessories are suitable for use within the patient environment.*

1.6 Radiation protection guidelines

The device emits X-ray radiation for medical purposes. The unit may cause an injury if used improperly. The instructions contained in this manual must be read and followed when operating the FOCUS. All government and local regulations pertaining to radiation safety must be observed.

NOTE! *for USA:*

Many provisions of these regulations are based on recommendations of the National Council on Radiation Protection and Measurements. Recommendations for dental x-ray protection are published in NCRP Report #35 available from NCRP Publications, 7910 Woodmont Avenue, Suite 1016, Bethesda, MD 20814.

Personal radiation monitoring and protective devices are available and recommended for staff members. It is also recommended to provide the patient with a protective apron. Consult the physician before taking images of pregnant patients.

WARNING! *FOCUS must not be used in rooms where explosive hazards exist.*

Use FOCUS with radiation protection in accordance with IEC 601-1-3:1994 (and/or local requirements).

PROTECTION BY DISTANCE

In all examinations the user of the x-ray equipment should wear protective clothing. The operator does not need to be close to the patient during normal use. The protection against scatter radiation can be achieved by using the remote control or the remote exposure button not less than 7 feet (2 meters) from the focal spot and the x-ray beam. The cable length of the optional remote exposure button is approximately 32 feet (10 meters). The operator should maintain visible contact with the patient and technique factors. This allows immediate termination of radiation by the release of the exposure button in the event of a malfunction or disturbance.

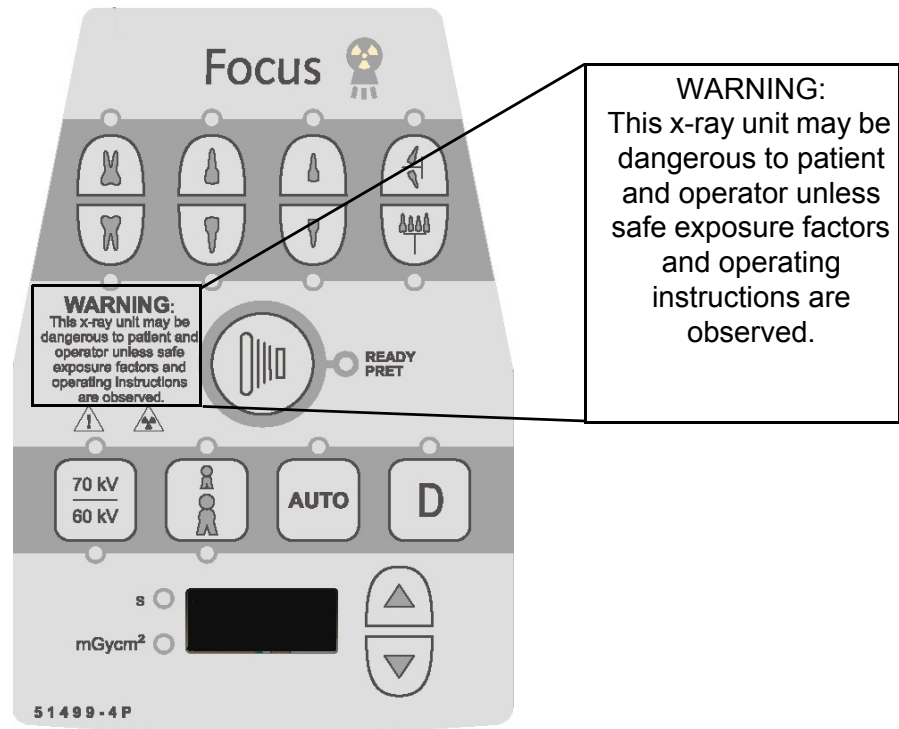

Table 1.1 Caution information on remote control

1.7 Manufacturer's liability

As a manufacturer we can only assume liability of safe and reliable operation of this unit when

- FOCUS installation was performed according to the FOCUS Installation Manual
- FOCUS is used according to the FOCUS User's Manual
- Maintenance and repairs are performed by a qualified FOCUS dealer
- Original or authorized spare parts are used

If service on the unit is performed, a work order describing the type and extent of repair must be provided by the service technician. This must contain information of changes of nominal data or work range performed. The work order must furthermore indicate the date of repair, the name of the company concerned and a valid signature. User should keep this work order for future references.

1.8 Disposal

When the unit does no longer meet the manufacturer's intended operational specifications, despite proper maintenance and repair, then the unit is no longer serviceable and should be replaced. Follow all regulations on disposal of waste parts. FOCUS has at least the following parts that should be regarded as non-environmentally friendly waste products:

















- X-ray source assembly
- All electronic circuits



2 Equipment controls

2.1 Main parts

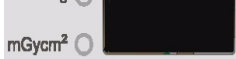

2.2 Symbols on remote control

	Maxillary molar
	Maxillary premolar/canine
	Maxillary incisors
	Bitewing
	Mandibular molar
	Mandibular incisor/bicuspid
	Mandibular cuspid
	Occlusal
	Exposure button
	X-ray source assembly: emitting
	Ready for exposure
	Patient Size Selection
	Digital mode selection
	Voltage selection, 60 or 70 kV
	Attention, consult accompanying documents
	Radiation warning
	Exposure time & DAP display

	Exposure time control
	AUTO (AEC: Automatic Exposure Control) Selection

2.3 Focus with SmartBox option



- 1. SmartBox
- 2. Sensor selection button, both sides
- 3. Sensor selection indicator (LED) lights
- 4. Sensor connector module
- 5. Sigma-sensor
- 6. Sensor holder

	Sensor selection
---	------------------

2.4 Unit mount model Focus

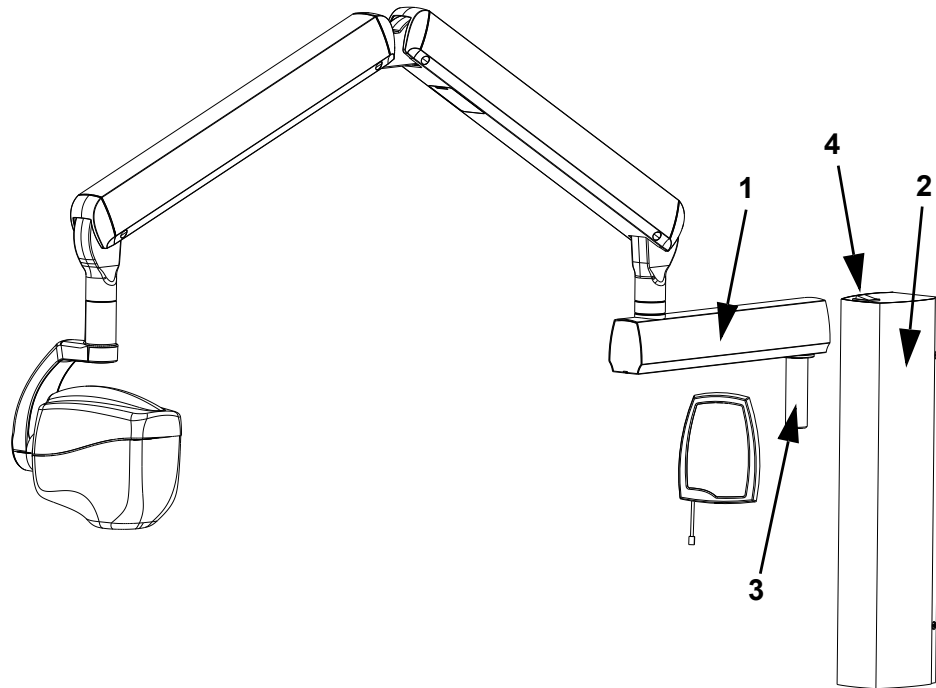

1. Horizontal arm
2. Generator module
3. Shaft of the horizontal arm
4. Main switch

Switch on the unit

The power switch is located on the end of the generator module. Turn the switch to the ON position.



Changing the fuses

The fuses are located in the generator module. To change the fuses open the generator module cover by opening the four screws on the side of the cover.

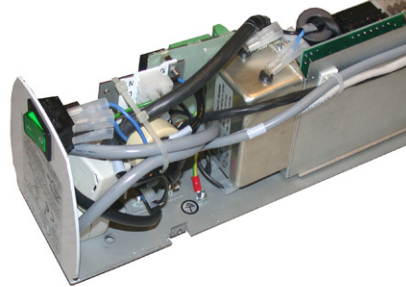

3 Preparations for the exposure

3.1 Precautionary actions for safe use

Check that the site of the unit allows FOCUS to be set in all positions without making contact with any objects.

WARNING! *Proper grounding cannot be ensured unless FOCUS is connected to properly wired hospital grade outlet.*

3.2 Switching the power on

The power switch is located on the bottom of the access block. Turn the switch to the ON position. The green light indicator will illuminate. The system will reset and run a self-test.

The remote display will light up and read the previously used exposure time. Also, light indicators will illuminate representing the previously used values for the digital, Auto and kV selection.

The green READY light will illuminate when an exposure can be made.

WARNING! *Shut down the unit in case of erroneous or unexpected operation.*

3.3 Selecting the cone

Cone selection includes round or rectangular short or long cones.

If a cone with different length from that set in the factory is needed, go to programming mode and select the desired cone length as described in the “*Program Mode*” section of this manual. Remove the cone by rotating it and pulling it out. Then push and rotate the new cone in. RINN, or other types of film/sensor holders can be used with these cones.

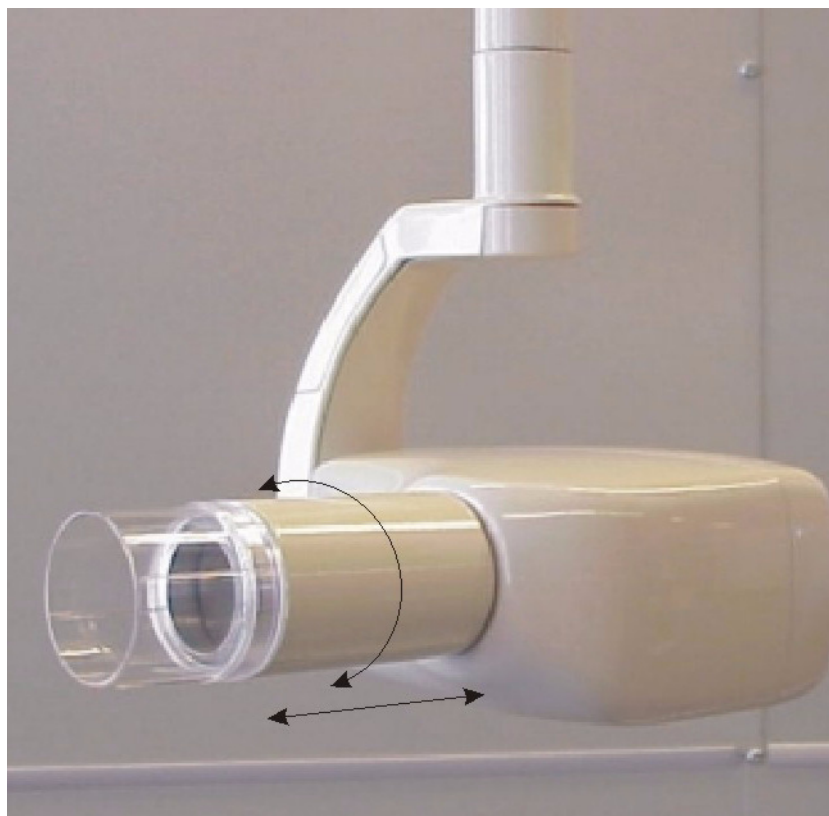

NOTE! Make sure that the values set in the programming mode correspond to the cone length and shape.

3.4 Selecting the exposure parameters

1. Press the kV button to toggle between the two choices, 60 kV or 70 kV. The LED will indicate the selection.
2. Press the patient size button to toggle between the two choices, Adult and Pediatric. The adjacent light will indicate the selection.
3. Press the D button to select between Film and Digital mode. The light is ON in Digital mode.

CAUTION! Assure that the right image capture device mode (Film/Digital) is on.

Use of the AEC is recommended when FocusLink is connected. Then select only the kV. See Chapter 3.6.

4. Press one of the buttons representing the eight anatomical time settings (tooth buttons). The adjacent light indicator will illuminate corresponding to the selection. All other tooth button light indicators will be off.

5. The exposure time may be adjusted manually with the UP and DOWN buttons. The exposure time is based on the tooth type, patient size, exposure mode (film or digital), value of kV, film speed and cone length. The exposure time is shown on the display to two decimal places. Whenever one of the determining parameters is changed, the value for the exposure time is recalculated and the display is updated.
6. Close the door if a door switch is installed.

3.5 Positioning the patient

1. Set the patient's head into correct position according to selected imaging modality.
2. Place the film packet /sensor into the patient's mouth. Bring the tube head close to the patient's skin and aim the beam towards the film/sensor observing the correct angle of the beam. The horizontal angle of the cone is indicated on the scale located around the vertical joint of the tube head.



Maxillary anterior Maxillary molar Mandibular

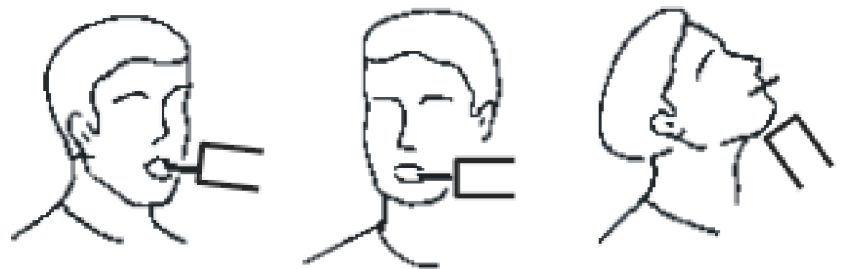

Mandibular canine Mandibular molar Mandibular



Maxillary occlusal Bite-wing

3. Use the focal length as long as possible to keep the absorbed dose as low as reasonably achievable.
4. Instruct the patient to avoid any movement during the exposures.

WARNING! *Take care not to hit the patient with the unit during the positioning of the patient.*

3.6 AEC Automatic Exposure Control

AEC function is for controlling the exposure time automatically. This feature is possible only with Sigma intraoral digital sensor system from Instrumentarium Dental. AEC function is achieved by data exchange over FocusLink digital communication line between Sigma and Focus. Communication makes also possible that exposure times, kV and mA are transferred automatically from Focus to user application software in both manual and automatic exposure modes. FocusLink is a separate item of Sigma accessory list, see Sigma manual.



AEC is controlled from Focus control panel. Operation of Sigma or user application software is not changed. AEC functions only after Sigma has been connected to Focus and Focus is operational. When AEC is selected from Focus, Sigma changes its internal operation to support the AEC function.

AEC can be turned on and off with the AUTO button, which always turns on the digital mode unless the digital mode is on already. Deselection of digital mode always deselects AEC mode too. When AUTO is selected, the display of remote controls is inactive. After an exposure the exposure time is displayed, however.

3.7 Focus with SmartBox

For operating and installation instructions, see Sigma user & installation manual.

3.8 Making an exposure

1. READY light will illuminate on the remote control when the unit is ready for exposure.
2. Use either the handheld/wall external exposure switch or the exposure button on the remote control.
3. Press and hold the exposure button through the entire exposure cycle until the audible signal terminates.

NOTE! *In the AUTO (AEC) mode the time of pressing is a little longer than in the manual mode.*

During the exposure, the yellow warning light will illuminate and the beeper will be activated. These two actions will stop when the exposure is completed or if the exposure button is released prematurely. The exposure time display will go blank during the exposure and will reflect the elapsed time of the actual exposure afterwards.

NOTE! *When using the system in an extremely high electromagnetic environment interferences may change image quality. If interference appears, contact your FOCUS dealer.*

3.9 Monitoring of dose levels



The calculated dose is displayed as the product of dose and beam area as measured by a dose area product (DAP) mGycm² and can be observed from the remote control panel.



To see the DAP value (mGycm²) after an exposure, press the “digital mode” and “down” button simultaneously.

The DAP value is shown approx. 5 seconds while the mGycm² LED light is illuminated.

NOTE! *The DAP value is depended on the selected cone. Before reading the DAP value, be sure that the right cone type is selected from program mode (see chapter 4).*

4 Program mode

Enter or exit the program by pressing and holding the kV button for two seconds or more. The beeper will sound three times. No exposures may be taken while in the program mode. The READY light will be off.

The menu selections are scrolled with the UP and DOWN buttons. Enter or exit the selection by pressing the kV button. Data is edited with the UP button.

The program mode will exit automatically after it remains idle for 30 seconds. When control returns to the operating mode, the display will show the updated exposure time.

Menu Selections	Display Contents
Film Speed	Pr1
<i>fast film (Speed F)</i>	<i>SF</i>
<i>fast film (Ekta speed, E)</i>	<i>SE</i>
<i>slow film (Ultra speed, D)</i>	<i>Sd</i>
Cone selection	Pr2
<i>short round</i>	<i>1</i>
<i>short rectangular</i>	<i>2</i>
<i>long round</i>	<i>3</i>
<i>long rectangular</i>	<i>4</i>
<i>short rectangular for sensor size 1</i>	<i>5</i>
<i>short rectangular for sensor size 2</i>	<i>6</i>
Exposure Counter	Pr3
<i>First (0 - 999)</i>	<i>2 digits displayed</i>
<i>Second (1000 - 99000)</i>	<i>3 digits displayed</i>
Automatic AEC selection*	Pr4
<i>Automatic AEC selection ON</i>	<i>AEC</i>
<i>Automatic AEC selection OFF</i>	<i>---</i>
Set Factory Defaults, two beeps	Pr5
Speaker adjustment	Pr6
<i>speaker volume (1 = min. 8 = max.)</i>	<i>1-8</i>
DAP Cumulative Dose Area Product	Pr7
<i>to reset cumulative counter, press D</i>	
Sensor type selection**	Pr8
<i>generic</i>	<i>GEN</i>
<i>Sigma</i>	<i>SIG</i>
<i>Phosphor Plate</i>	<i>PHO</i>
Preheat boost adjustment ***	Pr9

Menu Selections	Display Contents
Film Speed (On, if generator revision 1.x) (Disabled, if generator revision 2.x)	Pr1 <i>On</i> <i>DIS</i>

* If FocusLink is connected, the “D” is always switched on, when the image capturing is started in CliniView. If AEC is selected in Pr4, the AEC is switched on also.

** Different exposure times can be programmed for each sensor type (similar way as described in 4.1 Programmable anatomical time settings)

*** This program applies only if the Focus firmware is 3.12 or greater. The parameter has been set properly in the factory. If the firmware need to be upgraded in field, set this parameter correctly according to the generator revision.

4.1 Programmable anatomical time settings

The anatomical time settings (tooth buttons) have been preprogrammed by the factory but can be changed if necessary by the user. This is done similarly to programming the preset buttons on a car radio. First increase or decrease the exposure time with UP and DOWN buttons. Then press and hold the corresponding tooth button for two seconds or more. The beeper will beep two times. The new time setting is now saved into the memory.

5 Error messages

The error messages are grouped into two categories. User errors (H) and system fault errors (E). User errors must either be acknowledged or it will be removed once the error is corrected. When system faults occur, a service technician should be contacted.

Display Contents	Error or Failure	Action
E1	KV failure	Contact the service
E2	MA failure	Contact the service
E3	PREH failure	Contact the service
E4	Tube head too hot or too cold	Wait for valid tube head temperature
E5	Line voltage low	Contact the service
E6	Sigma link error or sensor not ready	Contact the service
E7	EEPROM failure	Contact the service
H1(necessary waiting time)	Duty cycle	Wait for tube to cool
H2(flashes alternately with elapsed exposure time)	Premature button release	Acknowledge with UP or DOWN button
H3	Door switch open (connected to Adjustment part)	Check that door is closed
H4	Door switch open (connected to Remote) Control Panel	Check that door is closed
H5	System in Service mode	Go to the user mode

Display Contents	Error or Failure	Action
H6	Current Sigma clocking mode and resolution selection do not support AEC.	Change resolution mode to minimum dose in CliniView. This error message may appear only with CliniView 3.0 or earlier
H7	Exposure out of range, exposure cancelled (in AEC mode)	Too much attenuation between the sensor and the tube. Check that the tubehead and the sensor are correctly aligned.

6 Maintenance

6.1 Cleaning

The cone should be cleaned after every patient usage. Items and surfaces that are not given special instructions for cleaning, disinfecting and sterilizing, can be cleaned with a soft cloth moistened with disinfectant after each usage.

WARNING! *Always disconnect focus from the power supply or switch off the power prior to cleaning or disinfecting the unit. Do not allow any liquid to enter the unit interior.*

CAUTION! *Do not allow water or other cleaning liquids to enter the unit interior since these may cause damage.*

CAUTION! *See Smart Box sensor module cleaning instructions on the Sigma User and Installation Manual.*

Use a cloth moistened in cool-to-lukewarm, soapy water to clean the unit, and prevent coagulation and thus facilitate the removal of protein substances. Then wipe with a cloth moistened in clear water. Mild detergent solution can be used. Never use solvents of any kind. If you are uncertain of the nature of cleaning agent, do not use it.

For example, the following cleaning agents are allowed (and not allowed) to clean the unit panels:

Allowed:

Soap, Butylalcohol, Ethanol (ethyl alcohol) 96%, Methanol (methyl alcohol).

Not allowed:

Benzene, all chlorine solutions, Phenol, Acetone, Acetic ether

6.2 Disinfecting

Use Ethanol 96% for disinfecting of equipment. Wipe manually with clean cloth moisturized in disinfectant solution. Never use corrosive or solvent disinfectants. All items and surfaces should be dried before next usage.

NOTE! *Wear gloves and other protective gear during disinfecting process.*

WARNING! *Do not use any disinfecting sprays since the vapor could ignite causing injury.*

Disinfecting techniques for both the unit and the room must comply with all laws and regulations that have jurisdiction within which the unit is located.

6.3 Periodic maintenance

This unit is designed to provide reliable performance and many years of customer satisfaction. In order to assure safe performance, the unit must be checked by a qualified service technician. It is the owner's responsibility to supply or arrange for this service. Consult your Focus dealer for such service. In addition to periodic maintenance any deviation from normal performance should be immediately reported to your dealer.

WARNING! *Only trained and qualified personnel should be permitted to access the internal parts of the focus unit.*

CAUTION! *After the operation in the service mode the unit must be switched off.*

The user should perform the following inspections on a monthly basis:

- Visually check that all visible labels are intact and legible
- Visually check that the exposure indicator light illuminates for the duration of exposure
- Confirm that the audible indicator beeps for the duration of the exposure
- Check that exposure button must be kept pressed continuously during the exposure cycle
- Check that exposure terminates when the exposure button is prematurely released
- Check all the functions of the remote control.

Test for exposure time limiter in AEC mode:

Focus prevents the exposure, if the sensor in patient's mouth is not connected to the unit. The function of this security feature can be tested as follows:

Aim the beam away from the sensor. Expose with both kVs. Focus should stop the exposure and display H7 error.

7 Technical data

7.1 Technical specifications

MANUFACTURER:	Instrumentarium Dental Nahkelantie 160 (P.O. Box 20) FIN-04300 Tuusula, FINLAND
MANUFACTURER'S QUALITY SYSTEM:	In accordance with ISO13485 and ISO9001 standard
ENVIRONMENTAL MANAGEMENT SYSTEM:	In accordance with ISO 14001 standard
ELECTRICAL & MECHANICAL SAFETY:	According to IEC 60601-1, CE models marked according to the Medical Device Directive 93/42/ EEC

PRODUCT NAME	FOCUS
TYPE	Intraoral x-ray unit

UNIT DATA	
Class	I
Type	B
Protection	IP-20
Operation	Continuous operation with intermittent loading
Software version	3.0 or higher

X-RAY GENERATOR	
Generator type	Constant potential
Nominal power	490 W
High voltage	DC
Supply frequency	100-200 kHz
Number of phases	1
Reference current time product	7 mAs (70 kV, 7 mA, 1 s)
Lowest current time product	0.14 mAs (70 kV, 7 mA, 0.02 s)

DENTAL CARE UNIT MOUNT MODEL FOCUS	
Horizontal arm length	330 mm (from axl to axl), 418 mm (total length)
Generator module length	500 mm
Horizontal arm shaft diameter	32 mm

Main cable length	5230 mm (measured from generator module to the scissors arm)
-------------------	---

TUBE HEAD ASSEMBLY	
Tube head assembly type	THA-I
Tube type	Toshiba D-0711SB or D-0711S
Max. tube voltage	60 or 70 kV
Max. tube current	7 mA
Max. electric output	490 W (70kV; 7mA; 0.1s)
Reference axis	Runs axially with the cone
Target angle	16 degrees
Focal spot	0.7 mm (IEC 60336)
Nominal anode input power	940 W
Max. symmetrical radiation field	∅60 mm at a 200 mm focal length
Total filtration	2 mm Al (70 kV)
Inherent filtration	2 mm Al (70 kV)
Additional filtration	0 mm Al (70 kV)
Max. anode heat content	7 kJ
Maximum X-ray tube assembly heat content	140 kJ
Maximum continuous heat dissipation of the X-ray tube head assembly	19 W

ELECTRICAL CONNECTIONS	
Nominal mains voltage	115 VAC +/- 10% 230 VAC +/- 10%
Input power frequency	60 Hz 50 Hz
Nominal current	7.63A 3.55A
Mains fuse, slow blow	6.25AT
Apparent resistance of supply mains	0.68Ω
Power consumption	816 VA / 230 VAC 877 VA / 115 VAC
US/Canada mains connector type	115 V / NEMA 6-15P or similar type
Power supply cords type	H05VV5-F / AWG 14 (UL 2587)

WARNING! *Proper grounding cannot be ensured unless FOCUS is connected to properly wired hospital grade outlet.*

NOMINAL SHORTEST IRRADIATION TIME	0.02 s
EXPOSURE TIME RANGE	0.02 - 3.2 s
EXPOSURE TIME RANGE IN AEC MODE	0.02- 1.6 s

BEAM LIMITING DEVICE	
Cone dimensions	Round: \varnothing 60 mm
	Rectangular: 35 x 45 mm

PHYSICAL MEASURES AND AMBIENT TEMPERATURES:	
Focal length (Standard/Long)	229 mm (9 inches) / 305 mm (12 inches)
Installation	Standard wall mount Optional base for free standing unit
Height x Width x Depth (mm)	Unit: 1059 mm x 279 mm x 946/ 1096/1346 mm Tube head assembly: 112 mm x 260 mm x 201 mm
Weight	Unit: approximately 30 kg (66 pounds) Tube head assembly: approximately 4.5 kg (10 pounds)
Type and length of the cable of the remote exposure switch	Length approximately 10 m (32.5 feet), RJ-45 plug at both ends (8 wires)
Transportation and Storage	-40°...+70°C (-40F...+158F) RH 10...100%
Operation Temperature	+10°...+40°C (+50F...+104F) RH max. 70%

DOSE AREA PRODUCT (DAP)								
kVp corrected DAP								
	Short round cone (9")		Long round cone (12")		Short rectangular cone (9")		Long rectangular cone (12")	
	60kV	70kV	60kV	70kV	60kV	70kV	60kV	70kV
set exposure time (s)	DAP mGycm ²	DAP mGycm ²	DAP mGycm ²	DAP mGycm ²	DAP mGycm ²	DAP mGycm ²	DAP mGycm ²	DAP mGycm ²
0,020	2,9	3,8	1,8	2,2	1,6	2,1	1,0	1,2
0,025	3,7	5,0	2,3	2,8	2,1	2,8	1,3	1,6
0,032	4,9	6,6	2,9	3,7	2,7	3,7	1,6	2,1
0,040	6,2	8,3	3,6	4,7	3,5	4,6	2,0	2,6
0,050	7,8	10,4	4,6	6,3	4,4	5,8	2,6	3,5
0,063	9,9	13,2	5,8	7,5	5,5	7,4	3,2	4,2
0,080	12,7	16,9	7,4	9,5	7,1	9,4	4,1	5,3
0,100	15,9	21,3	9,2	12,1	8,9	11,9	5,1	6,7
0,125	20,0	26,8	11,5	15,1	11,1	14,9	6,4	8,4
0,160	25,8	34,5	14,7	19,9	14,4	19,2	8,2	11,1
0,200	32,4	43,2	18,4	24,8	18,0	24,1	10,2	13,8
DOSE AREA PRODUCT (DAP).								
kVp corrected DAP								
	Short round cone (9")		Long round cone (12")		Short rectangular cone (9")		Long rectangular cone (12")	
	60kV	70kV	60kV	70kV	60kV	70kV	60kV	70kV
set exposure time (s)	DAP mGycm ²	DAP mGycm ²	DAP mGycm ²	DAP mGycm ²	DAP mGycm ²	DAP mGycm ²	DAP mGycm ²	DAP mGycm ²
0,250	40,5	54,4	23,0	30,5	22,6	30,3	12,8	17,0
0,320	52,1	69,7	29,4	38,9	29,0	38,9	16,4	21,7
0,400	65,2	87,4	36,7	48,9	36,3	48,7	20,5	27,2
0,500	81,7	109,7	45,9	61,1	45,5	61,1	25,6	34,1
0,630	103,0	138,1	57,8	77,1	57,4	76,9	32,2	42,9
0,800	130,7	175,5	73,2	97,7	72,8	97,8	40,8	54,4
1,000	163,2	219,4	91,5	122,1	90,9	122,2	51,0	68,0
1,250	204,0	274,2	114,5	152,8	113,6	152,8	63,8	85,1
1,600	260,7	350,5	146,5	196,2	145,3	195,3	81,6	109,3
2,000	325,5	437,3	182,7	246,3	181,3	243,7	101,8	137,2
2,500	405,7	546,7	228,1	308,1	226,0	304,6	127,1	171,7
3,200	518,5	697,1	291,2	393,2	288,9	388,4	162,3	219,1

8 User's statement

Instructions for the use of the FOCUS and precautionary statements are part of the FOCUS *User's Manual*.

RADIATION LEAKAGE TECHNIQUE FACTORS

The maximum-rated peak tube potential is 70 kVp with the maximum rated continuous tube current of 1.5 mA.

BEAM LIMITING DEVICE / TUBE HOUSING ASSEMBLY COMPATIBILITY

The tube housing assembly THA-I is compatible with the beam limiting device.

Part number	Cones
50540	Short cone round
50550	Short cone rectangular
50410	Long cone round
50420	Long cone rectangular
50750	Short full metal rectangular cone
50720	Long full metal rectangular cone
50551	Short cone rectangular for Germany

EQUIPMENT STATEMENT FOR TUBE HOUSING ASSEMBLY

Maximum operating voltage is 70 kVp. Nominal focal spot is 0.7 mm.

X-ray tube: Toshiba D-0711SB or D-0711S. For additional information please refer to the tube specification sheets.

MAXIMUM DEVIATION FROM INDICATED VALUES

PARAMETER	INDICATED VALUE	DEVIATION
Tube voltage	60 - 70 kVp	± 4%
Tube current	7 mA	± 10%
Exposure time	0.02 - 3.2 s	(± 10% + 1ms)

POWER SUPPLY REQUIREMENTS

Rated nominal voltage 115 / 230 VAC, 60 / 50 Hz single phase. Line voltage range is $115 \pm 10\%$ and $230 \pm 10\%$ VAC. Automatic regulation for all voltages within the line voltage range.

MAXIMUM LINE CURRENT

With 115 VAC power supply systems the maximum line current during the exposure is 8 A, at stand by maximum 0.2 A. The system line fuses are 6.25 A slow blow type.

With 230 VAC power supply systems the maximum line current during the exposure is 5 A, at stand by maximum 0.1 A. The system line fuses are 6.25 A slow blow type.

TUBE RATINGS, TUBE HEAD COOLING CURVE

MAXIMUM RATING CHARTS (ABSOLUTE MAXIMUM RATING CHARTS)

DC

FOCAL SPOT : 0.7 mm

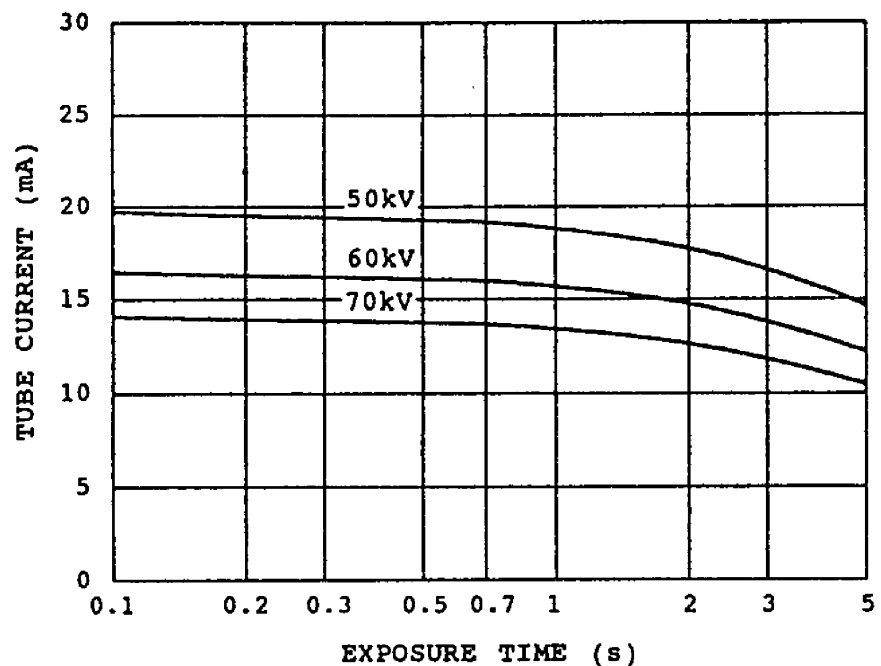

Fig 8.1. Maximum Rating Chart (D-0711SB or D-0711S)

ANODE THERMAL CHARACTERISTICS

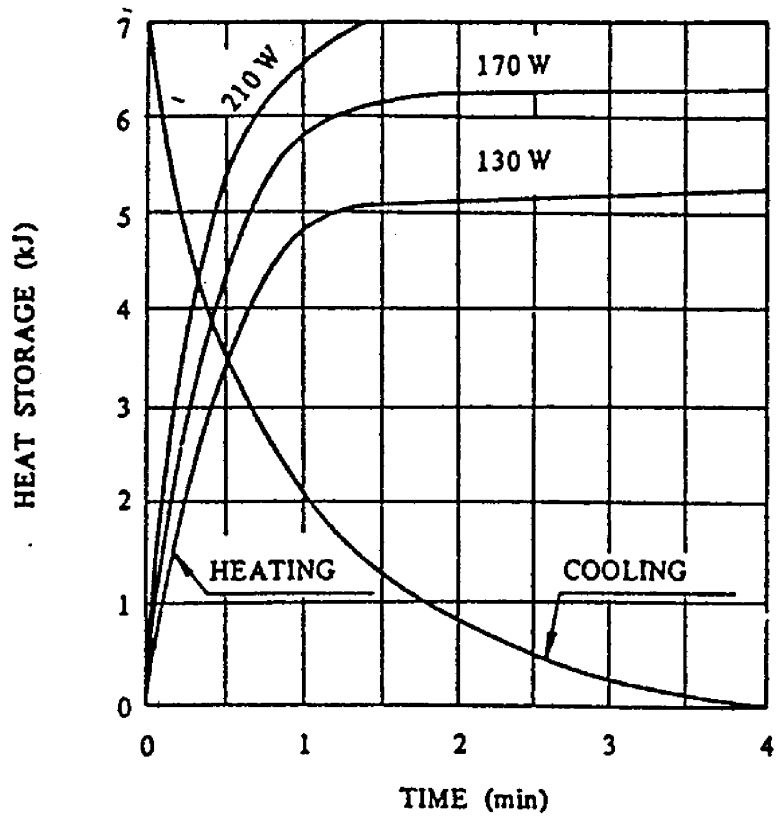

Fig 8.2. Tube anode thermal characteristics (D-0711SB or D-0711S)

TUBE HEAD THERMAL CHARACTERISTICS

TUBEHEAD THERMAL CHARACTERISTICS

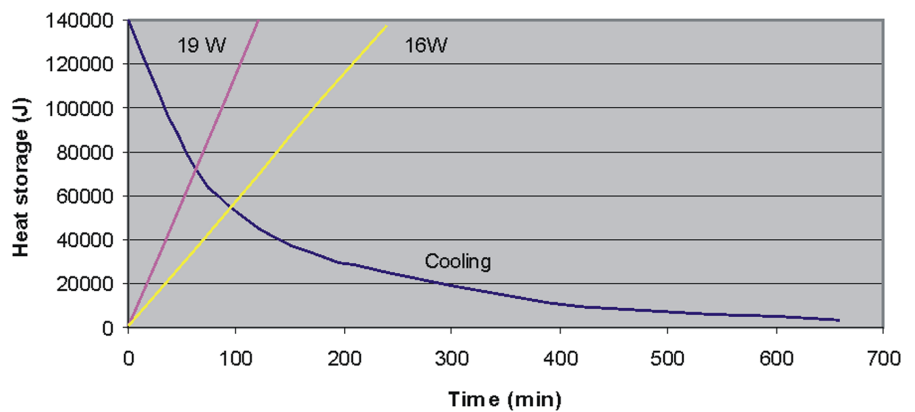

Fig 8.3. Tube head assembly cooling curve

WAIT TIMES BETWEEN EXPOSURES

Below are the wait times for different exposures.

Exp. time	Wait time	Exp. time	Wait time
0.02s	10s	0.32s	10s
0.03s	10s	0.40s	10s
0.04s	10s	0.50s	10s
0.05s	10s	0.63s	19s
0.06s	10s	0.80s	24s
0.08s	10s	1.00s	30s
0.10s	10s	1.25s	50s
0.12s	10s	1.60s	64s
0.16s	10s	2.00s	80s
0.20s	10s	2.50s	100s
0.25s	10s	3.20s	128s

DIMENSIONAL OUTLINE OF THE TUBEHEAD

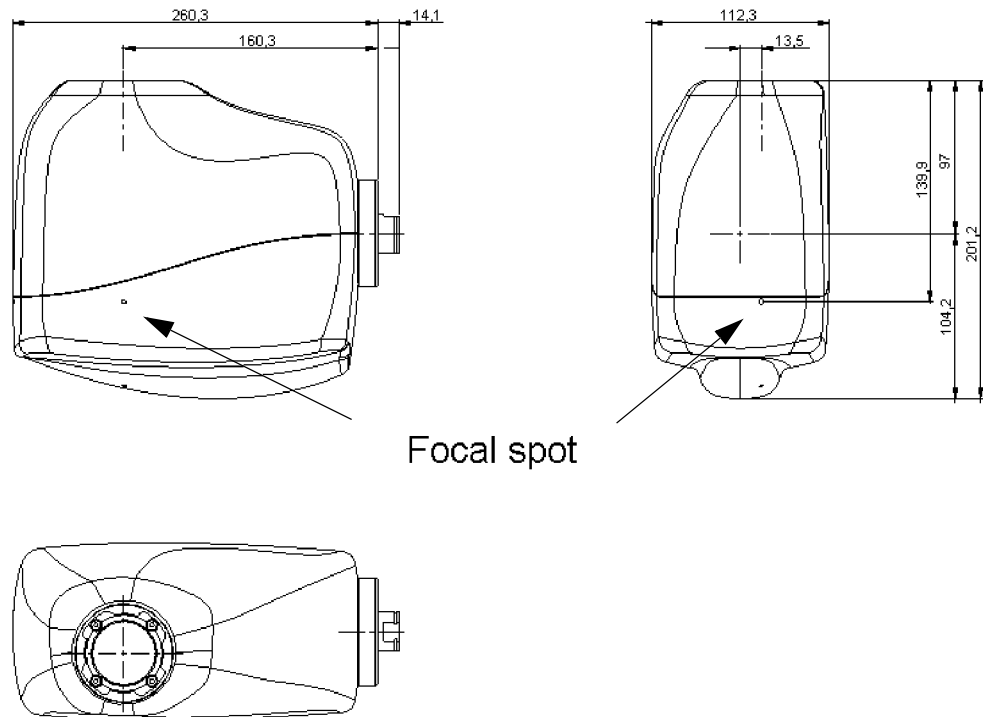

Fig 8.4. Tubehead dimensions and the location of the focal spot

NOTE! *Wiring diagrams, schematics, and other documents which are needed for repairing the unit, will be supplied by Instrumentarium Dental on request.*

MEASUREMENT CRITERIA FOR LOADING FACTOR CONDITIONS

Exposure time

Exposure time consists of beginning and ending points as measured by a calibrated x-ray monitor at 70% of the peak radiation waveform

kVp

The high voltage peak value measured over the high voltage feedback resistor with a calibrated voltage device

mA

The tube current mean value calculated by dividing the voltage over the feedback resistor value. The voltage is measured with a calibrated voltage device.

The nominal x-ray voltage 70kV is obtained at highest tube current 7mA.

The nominal tube current 7mA is obtained at the highest tube voltage 70kV.

The max. electric output is obtained at 70 kV tube voltage and 7 mA tube current.

The nominal power/exposure: 490 W

Instrumentarium Dental reserves the right to make technical changes at any time.

9 Recommended digital/film exposure times

	60kV, 7mA				70kV, 7mA			
	9" cone		12" cone		9" cone		12" cone	
	Adult	Child	Adult	Child	Adult	Child	Adult	Child
Bitewing	0,250	0,160	0,500	0,300	0,125	0,080	0,250	0,160
Maxillary incisor	0,200	0,125	0,400	0,250	0,100	0,063	0,200	0,125
Maxillary cuspid	0,200	0,125	0,400	0,250	0,100	0,063	0,200	0,125
Maxillary molar	0,300	0,200	0,600	0,400	0,160	0,100	0,300	0,200
Occlusal	0,250	0,160	0,500	0,300	0,125	0,080	0,250	0,160
Mandibular incisor	0,200	0,125	0,400	0,250	0,100	0,063	0,200	0,125
Mandibular cuspid	0,250	0,160	0,500	0,300	0,125	0,080	0,250	0,160
Mandibular molar	0,250	0,160	0,500	0,300	0,125	0,080	0,250	0,160

Dig. = Digital sensors

SD = Speed D

SE = Speed E

SF = Speed F

Instrumentarium Dental reserves the right to make changes in specification and features shown herein, or discontinue the product described at any time without notice or obligation. Contact your Instrumentarium Dental representative for the most current information.

Copyright © 11/2008 by PaloDEX Group Oy. All rights reserved.

Instrumentarium Dental
Nahkelantie 160, FI-04300 Tuusula, Finland
Tel. +358 45 7882 2000
Fax +358 9 851 4048

Americas:
Instrumentarium Dental Inc.
Milwaukee, Wisconsin, U.S.A.
Tel. 800 558 6120
Fax 414 481 8665



INSTRUMENTARIUM

Focus

User Manual, English

51774-IMG rev 8 Printed in Finland 11/2008