

This publication, photographs, illustrations and software are under the protection of international copyright laws and all rights reserved. It does not allow any reproduction of this manual, content and any materials contained herein without the written consent of the authentic manufacturer.

The information in this manual is subject to change without notice. The manufacturer does neither represent nor warrant the contents hereof; and specifically disclaims any implied warranties of merchantability or fitness for any particular purpose. Furthermore, the manufacturer reserves the right to revise and change this publication from time to time, without the obligation of notifying any person of such revision or changes.

## Trademarks

IBM, VGA, and PS/2 are registered trademarks of International Business Machines.

AMD and Duron are registered trademarks of Advanced Micro Devices Inc.

Microsoft, MS-DOS and Windows 98/ME/NT/2000/XP are registered trademarks of Microsoft Corporation.

PC-cillin is a trademark of Trend Micro Inc.

AMI is a trademark of Award Software Inc.

A3D is a registered trademark of Aureal Inc.

MediaRing Talk is a registered trademark of MediaRing Inc.

3Deep is a registered trademark of E-Color Inc.

SiS is a trademark of Silicon Integrated System Corporation.

Other names used in this publication may be trademarks and are acknowledged.

**Copyright © 2003  
All Rights Reserved  
KOB 740 FDMx Series  
V7.5A  
S740/May 2003**

## Notice:

Owing to Microsoft's certifying schedule is various to every supplier, we might have some drivers not certified yet by Microsoft. Therefore, it might happen under Windows XP that a dialogue box (shown as below) pop out warning you this software has not passed Windows Logo testing to verify its compatibility with Windows XP. Please rest assured that our RD department has already tested and verified these drivers. Just click the "Continue Anyway" button and go ahead the installation.



## Table of Contents

Trademarks .....	I
Chapter 1: Introduction.....	1
Key Features.....	2
Package Contents.....	6
Static Electricity Precautions.....	7
Pre-Installation Inspection.....	7
Chapter 2: Mainboard Installation.....	8
Mainboard Components .....	9
I/O Ports.....	9
Installing the Processor.....	10
Installing Memory Modules .....	11
Jumper Settings .....	12
Install the Mainboard.....	13
Connecting Optional Devices.....	14
Install Other Devices .....	16
Expansion Slots .....	18
Chapter 3: BIOS Setup Utility.....	19
Introduction .....	19
Running the Setup Utility.....	20
Standard CMOS Setup Page.....	21
Advanced Setup Page.....	22
Power Management Setup Page .....	24
PCI / Plug and Play Setup Page.....	25
Load Optimal Settings.....	26
Load Best Performance Settings.....	26
Features Setup Page.....	27
CPU PnP Setup Page .....	29
Hardware Monitor Page.....	30
Change Password.....	30
Exit .....	31
Chapter 4: Software & Applications .....	32
Introduction .....	32
Installing Support Software.....	33
Bundled Software Installation .....	35



## Chapter 1

### Introduction

---

This mainboard has a **Socket-A** support for the **AMD K7** processors. The Socket-A processor's front-side bus speed is **266MHz**.

This mainboard integrates the **SiS740 Northbridge** and **SiS962L Southbridge** chipsets that support **DDR 266MHz**, **Ultra DMA 33/66/100/133** function and remarkably high system performance under all types of system operations.

The mainboard supports the built-in **AC97 Codec**, two 32-bit PCI slots, one **CNR** (Communications and Networking Riser) slot, and a built-in **10BaseT/100BaseTX Network Interface** (optional).

This mainboard has the **embedded 256-bit 3D AGP Graphics Accelerator** with 64MB frame buffer, supporting **AGP 4X 266MHz** mode up to 1GB/s bandwidth, which provides a direct connection between the graphics sub-system and memory so that the graphics do not have to compete for processor time with other devices on the PCI bus. The mainboard supports built-in **USB 2.0** providing higher bandwidth, implements **Universal Serial Bus Specification Revision 2.0** and is compliant with **UHCI 1.1** and **EHCI 0.95**.

There is a full set of I/O ports including two PS/2 ports for mouse and keyboard, one serial port, one parallel port, one VGA port and maximum six USB2.0 ports— four back-panel ports and onboard USB header USB2 providing two extra ports by connecting the Extended USB Module to the mainboard.

The board is **Micro ATX size** and has power connectors for an **ATX** power supply.

## Key Features

The key features of this mainboard include:

### Socket-A Processor Support

- ◆ Supports AMD **Athlon XP/Athlon/Duron** processors
- ◆ Supports **266 MHz** Front-Side Bus

### Chipset

There are **SiS740** Northbridge and **SiS962L** Southbridge in this chipset in accordance with an innovative and scalable architecture with proven reliability and performance. A few of the chipset's advanced features are:

- ◆ Integrate a high performance and high quality 3D/2D Graphical Accelerator, Video Accelerator and Motion Compensation MPEG1/MPRII Video Decoder
- ◆ Integrate a high performance 2.1GB/s DDR266 Memory controller to sustain the bandwidth demand from the integrated GUI, host processor, as well as the multi I/O masters
- ◆ Integrate one Universal Serial Bus 2.0 Host Controllers, the Audio Controller with AC97 Interface, the Ethernet MAC Controller w/ standard MII interface, three Universal Serial Bus 1.1 Host Controllers, the IDE Master/Slave controllers, and SiS MuTIOL technology

### Memory Support

- ◆ Two 184-pin DIMM sockets for DDR memory modules
- ◆ Support DDR 266MHz memory bus
- ◆ Maximum installed memory is 1GB

### VGA

- ◆ Embedded 256-bit 3D AGP Graphics Accelerator with 64MB frame buffer
- ◆ Supports AGP 4X 266 MHz mode up to 1GB/s bandwidth
- ◆ Supports 333MHz true-colorm RAMDAC, resolution up to 2048 x 1536 x 16 bpp NI
- ◆ Supports AGP Rev. 2.0 Spec. Compliant

### **Expansion Slots**

- ◆ One CNR (Communications and Networking Riser) slot
- ◆ Two 32-bit PCI slots for PCI 2.2-compliant bus interface

### **Onboard IDE channels**

- ◆ Primary and Secondary PCI IDE channels
- ◆ Support for PIO (programmable input/output) modes
- ◆ Support for Multiword DMA modes
- ◆ Support for Bus Mastering and Ultra DMA ATA 33/66/100/133 modes

### **Power Supply and Power Management**

- ◆ ATX power supply connector
- ◆ Meets ACPI 1.0b and APM 1.2 requirements, keyboard power on/off

### **AC97 Audio Codec**

- ◆ Compliant with AC'97 2.2 specification
- ◆ Full-duplex Codec with independent and variable sampling rate
- ◆ Earphone Buffer Built-In, SNR up to 90db
- ◆ 4Ch DAC, support 4-channel speak-out
- ◆ Advanced power management support

### **Onboard I/O Ports**

The mainboard has a full set of I/O ports and connectors:

- ◆ Two PS/2 ports for mouse and keyboard
- ◆ One serial port
- ◆ One VGA port
- ◆ One parallel port
- ◆ Six USB2.0 ports (four back-panel ports, onboard USB header providing two extra ports)
- ◆ Audio jacks for microphone, line-in and line-out

### **Built-in Ethernet LAN (optional)**

- ◆ **10Base-T/100Base-TX Physical Layer Solution**
- ◆ Dual Speed – 100/10 Mbps

- ◆ MII Interface to Ethernet Controller/Configuration & Status
- ◆ Auto Negotiation: 10/100, Full/Half Duplex
- ◆ Meet All Applicable IEEE802.3, 10Base-T and 100Base-TX Standards

### **USB 2.0**

- ◆ Compliant with Universal Serial Bus Specification Revision 2.0
- ◆ Compliant with Intel's Enhanced Host Controller Interface Specification Revision 0.95
- ◆ Compliant with Universal Host Controller Interface Specification Revision 1.1
- ◆ PCI multi-function device consists of two **UHCI Host Controller** cores for full-/low-speed signaling and one **EHCI Host Controller** core for high-speed signaling
- ◆ Root hub consists 4 downstream facing ports with integrated physical layer transceivers shared by **UHCI** and **EHCI** Host Controller
- ◆ Support PCI-Bus Power Management Interface Specification release 1.1
- ◆ Legacy support for all downstream facing ports

### **BIOS Firmware**

This mainboard uses AMI BIOS that enables users to configure many system features including the following:

- ◆ Hard drives, diskette drives, and peripherals
- ◆ Power management
- ◆ CPU parameters and memory timing
- ◆ Hardware monitoring parameters

The firmware can also be used to set parameters for different processor clock speeds.

### **Bundled Software**

- ◆ **PC-Cillin2002** provides automatic virus protection under Windows 98/ME/NT/2000/XP
- ◆ **MediaRing Talk** provides PC to PC or PC to Phone internet phone communication



- ◆ **3Deep** delivers the precise imagery and displays accurate color in your monitor
- ◆ **PC DJ** is a dual-MP3 player that enables users to actually mix music right on their own personal computers.
- ◆ **Adobe Acrobat Reader V5.0** is the software to help users read .PDF files.

### **Dimensions**

- ◆ Micro ATX form factor (24.4cm x 19cm)

---

***Note: Hardware specifications and software items are subject to change without notification.***

---

## Package Contents

Your mainboard package ships with the following items:

- The mainboard
- The User's Manual
- One diskette drive ribbon cable and bracket (optional)
- One IDE drive ribbon cable and bracket
- Software support CD

### **Optional Accessories**

You can purchase the following optional accessories for this mainboard.

- Extended USB module
- CNR v.90 56K Fax/Modem card
- Card Reader (You can buy your own Card Reader from the third party, but please contact your local Card Reader vendor on any issues of the specification and compatibility.)

## Static Electricity Precautions

Static electricity could damage components on this mainboard. Take the following precautions while unpacking this mainboard and installing it in a system.

1. Don't take this mainboard and components out of their original static-proof package until you are ready to install them.
2. While installing, please wear a grounded wrist strap if possible. If you don't have a wrist strap, discharge static electricity by touching the bare metal of the system chassis.
3. Carefully hold this mainboard by its edges. Do not touch those components unless it is absolutely necessary. Put this mainboard on the top of static-protection package with component side facing up while installing.

## Pre-Installation Inspection

1. Inspect this mainboard whether there are any damages to components and connectors on the board.
2. If you suspect this mainboard has been damaged, do not connect power to the system. Contact your mainboard vendor about those damages.

## Chapter 2

### **Mainboard Installation**

---

To install this mainboard in a system, please follow the instructions in this chapter:

- ❑ Identify the mainboard components
- ❑ Install a CPU
- ❑ Install one or more system memory modules
- ❑ Verify that all jumpers or switches are set correctly
- ❑ Install the mainboard in a system chassis (case)
- ❑ Connect any extension brackets or cables to connecting headers on the mainboard
- ❑ Install other devices and make the appropriate connections to the mainboard connecting headers.

**Note:**

1. Before installing this mainboard, make sure jumper JP1 is under Normal setting. See this chapter for information about locating JP1 and the setting options.
2. Never connect power to the system during installation; otherwise, it may damage the mainboard.

## Mainboard Components

Use the diagram below to identify the major components on the mainboard.

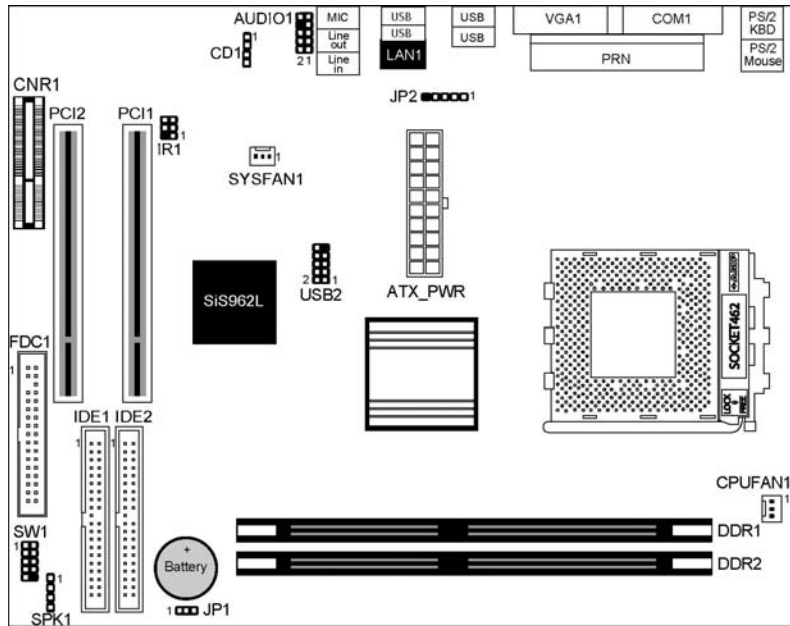

**Note:** Any jumpers on your mainboard that do not appear in the illustration above are for testing only.

## I/O Ports

The illustration below shows a side view of the built-in I/O ports on the mainboard.

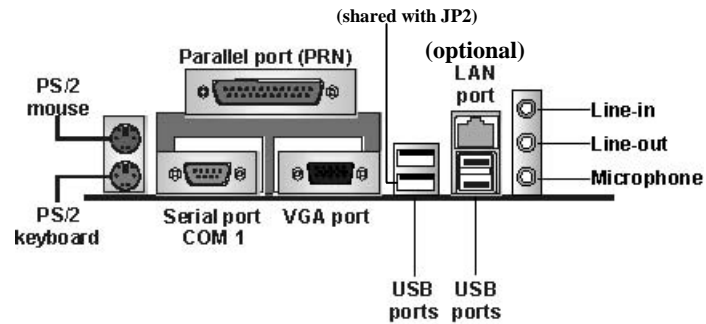

<b>PS/2 Mouse</b>	Use the upper PS/2 port to connect a PS/2 pointing device.
<b>PS/2 Keyboard</b>	Use the lower PS/2 port to connect a PS/2 keyboard.
<b>Parallel port (PRN)</b>	Use the PRN to connect printers or other parallel communications devices.
<b>COM1</b>	Use the COM port to connect serial devices such as mice or fax/modems. COM1 is identified by the system as COM1.
<b>VGA</b>	Use the VGA port to connect VGA devices.
<b>LAN Port (optional)</b>	Connect an RJ-45 jack to the LAN port to connect your computer to the Network.
<b>USB Ports</b>	Use the USB ports to connect USB devices. <i>Note: The lower USB port located beside the VGA port is shared with the JP2 connector</i>
<b>Audio Ports</b>	Use the three audio ports to connect audio devices. The first jack is for stereo Line-In signal. The second jack is for stereo Line-Out signal. The third jack is for Microphone.

## Installing the Processor

This mainboard has a Socket 462 processor socket. When choosing a processor, consider the performance requirements of the system. Performance is based on the processor design, the clock speed and system bus frequency of the processor, and the quantity of internal cache memory and external cache memory.

### CPU Installation Procedure

Follow these instructions to install the CPU:

1. Unhook the CPU socket's locking lever by pulling it away from socket and raising it to the upright position.
2. Match the pin 1 corner of CPU socket to the one of processor, and insert the processor into the socket. Do not use force.
3. Push the locking lever down and hook it under the latch on the edge of socket.
4. Apply thermal grease to the top of the CPU.

5. Lower the CPU fan/heatsink unit onto the CPU and CPU socket, and then use the retention module clamps to snap the fan/heatsink into place.
6. Plug the CPU fan power cable into the CPU cooling fan power supply (CPUFAN1) on the mainboard.

## Installing Memory Modules

This mainboard accommodates two 184-pin 2.5V unbuffered Double Data Rate SDRAM (DDR SDRAM) Dual Inline Memory Module (DIMM) sockets, and supports up to 1.0 GB of 266 MHz DDR SDRAM.

DDR SDRAM is a type of SDRAM that supports data transfers on both edges of each clock cycle (the rising and falling edges), effectively doubling the memory chip's data throughput. DDR DIMMs can synchronously work with 100 MHz or 133 MHz memory bus.

DDR SDRAM provides 1.6 GB/s or 2.1 GB/s data transfer rate depending on whether the bus is 100 MHz or 133 MHz. DDR SDRAM uses additional power and ground lines and requires 184-pin 2.5V unbuffered DIMM module.

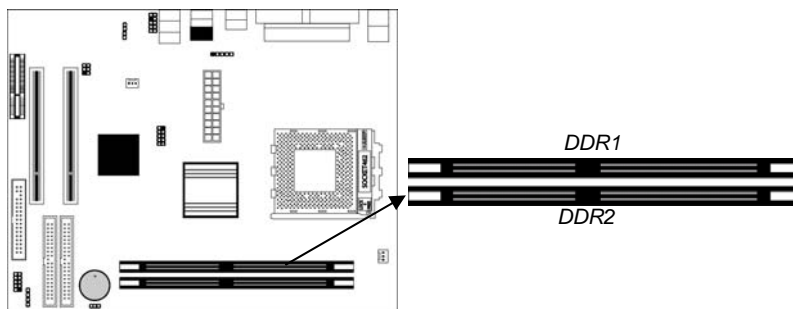

## Installation Procedure

These modules can be installed with up to 1 GB system memory. Refer to the following to install the memory modules.

1. Push the latches on each side of the DIMM socket down.
2. Align the memory module with the socket. The DIMM sockets are keyed with notches and the DIMMs are keyed with cutouts so that they can only be installed correctly.
3. Check that the cutouts on the DIMM module edge connector match the notches in the DIMM socket.
4. Install the DIMM module into the socket and press it firmly down until it is seated correctly. The socket latches are levered upwards and latch on to the edges of the DIMM.
5. Install any remaining DIMM modules.

## Jumper Settings

Jumpers are sets of pins connected together with jumper caps. The jumper caps change the mainboard's operation by changing the electronic circuits on the mainboard. If we connect two pins with a jumper cap, these pins are **SHORT**; if remove a jumper cap from these pins, they are **OPEN**.

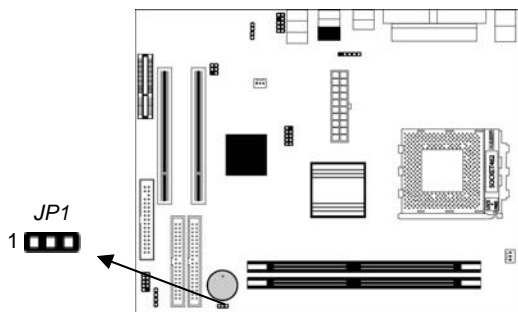



### Jumper JP1: Clear CMOS Memory

This jumper can clear the CMOS memory. You may need to clear the CMOS memory if the settings in the Setup Utility are incorrect that your mainboard can't operate. To clear the CMOS memory, disconnect all the power cables, and then move the jumper cap into the CLEAR setting for a few seconds.

Function	Jumper Setting
Clear CMOS Memory	Short Pins 1-2
Normal Operation	Short Pins 2-3

### Install the Mainboard

Install the mainboard in a system chassis (case). The board is a Micro ATX size mainboard. You can install this mainboard in an ATX case. Ensure your case has an I/O cover plate that matches the ports on this mainboard.

Install the mainboard in a case. Follow the instructions provided by the case manufacturer using the hardware and internal mounting points on the chassis.

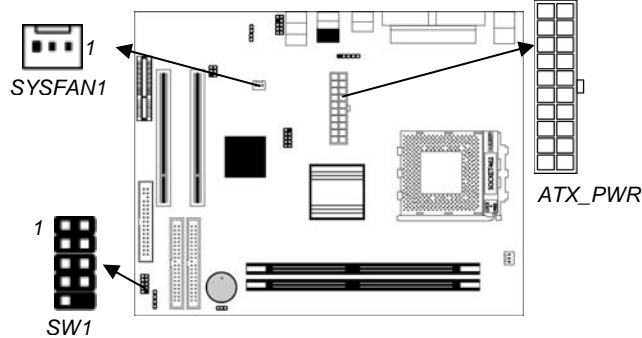

Connect the power connector from the power supply to the **ATX\_PWR** connector on the mainboard.  
 If there is a cooling fan installed in the system chassis, connect the cable from the cooling fan to the **SYSFAN1** fan power connector on the mainboard.  
 Connect the case switches and indicator LEDs to the **SW1** header.

Pin	Signal	Pin	Signal
1	HD_LED_P	2	FP PWR/SLP
3	HD_LED_N	4	FP PWR/SLP
5	RESET_SW_N	6	POWER_SW_P
7	RESET_SW_P	8	POWER_SW_N
9	RSVD_DNU	10	KEY

## Connecting Optional Devices

Refer to the following for information on connecting the mainboard's optional devices:

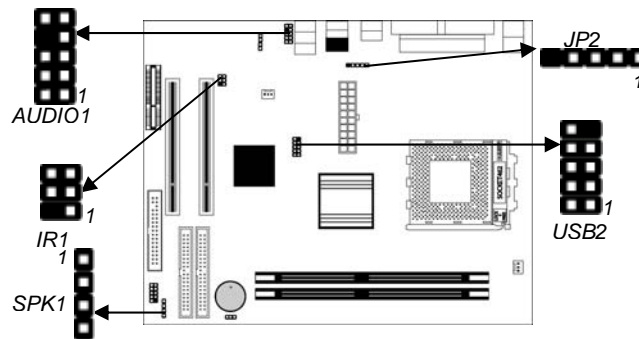

### SPK1: Speaker Connector

Connect the cable from the PC speaker to the **SPK1** header on the mainboard.

Pin	Signal	Pin	Signal
1	+5V	2	NC
3	GND	4	SPKR

### AUDIO1: Front Panel Audio Header

This header allows the user to install auxiliary front-oriented microphone and line-out ports for easier access.

Pin	Signal	Pin	Signal
1	AUD_MIC	2	AUD_GND
3	AUD_MIC_BIAS	4	AUD_VCC
5	AUD_FPOUT_R	6	AUD_RET_R
7	HP_ON	8	KEY
9	AUD_FPOUT_L	10	AUD_RET_L

### USB2: Front panel USB Connector

The mainboard has USB ports installed on the rear edge I/O port array. Additionally, some computer cases have USB ports at the front of the case. If you have this kind of case, use auxiliary USB connector USB2 to connect the front-mounted ports to the mainboard.

Pin	Signal	Pin	Signal
1	VERG_FP_USBPWR0	2	VERG_FP_USBPWR0
3	USB_FP_P0-	4	USB_FP_P1-
5	USB_FP_P0+	6	USB_FP_P1+
7	GROUND	8	GROUND
9	KEY	10	NC

1. Locate the USB2 header on the mainboard.
2. Plug the bracket cable onto the USB2 header.
3. Remove a slot cover from one of the expansion slots on the system chassis. Install an extension bracket in the opening. Secure the extension bracket to the chassis with a screw.

### JP2: USB Card Reader Connector (optional)

This connector is for connecting internal USB card reader. You can use a card reader to read or transfer files and digital images to your computer.

Pin	Signal	Pin	Signal
1	VCC	2	USB-
3	USB+	4	GND
5	KEY		

---

**!** The JP2 is shared with one of the USB ports of the I/O back panel. The USB port is located beside the serial port connectors. See "I/O Ports" for more information.

---

---

**!** Please check the pin assignment of the cable and the USB header on the mainboard. Make sure the pin assignment will match before plugging in. Any incorrect usage may cause unexpected damage to the system. The vendor won't be responsible for any incidental or consequential damage arising from the usage or misuse of the purchased product.

---

### IR1: Infrared Port

The infrared port allows the wireless exchange of information between your computer and similarly equipped devices such as printers, laptops, Personal Digital Assistants (PDAs), and other computers.

Pin	Signal	Pin	Signal
1	NC	2	KEY
3	+5V	4	GND
5	IRTX	6	IRRX

1. Locate the infrared port **IR1** header on the mainboard.
2. If you are adding an infrared port, connect the ribbon cable from the port to the IR1 header and then secure the port to an appropriate place in your system chassis.

### Install Other Devices

Install and connect any other devices in the system following the steps below.

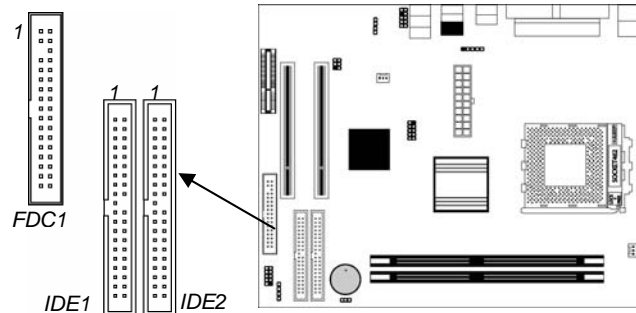

### Floppy Disk Drive

The mainboard ships with a floppy disk drive cable that can support one or two drives. Drives can be 3.5" or 5.25" wide, with capacities of 360K, 720K, 1.2MB, 1.44MB, or 2.88MB.

Install your drives and connect power from the system power supply. Use the cable provided to connect the drives to the floppy disk drive connector **FDC1**.

### IDE Devices

IDE devices include hard disk drives, high-density diskette drives, and CD-ROM or DVD-ROM drives, among others. The mainboard ships with an IDE cable supporting one or two IDE devices. If you connect two devices to a single cable, you must configure one of the drives as Master and one of the drives as Slave. The IDE device's documentation tells you how to configure a Master or a Slave device. The Master device connects to the end of the cable. Install the device(s) and connect power from the system power supply. Use the cable provided to connect the device(s) to the Primary IDE channel connector **IDE1** on the mainboard. If you want to install more IDE devices, you can purchase a second IDE cable and connect one or two devices to the Secondary IDE channel connector **IDE2** on the mainboard. If you have two devices on the cable, one must be Master and one must be Slave.

### Internal Sound Connections

If you have installed a CD-ROM drive or DVD-ROM drive, you can connect the drive audio cable to the onboard sound system.

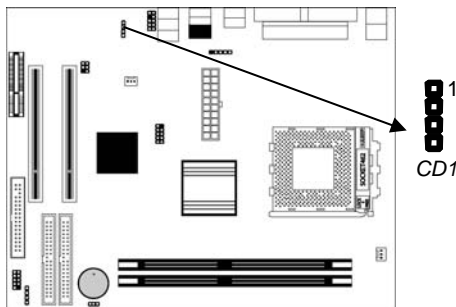

When you first start up your system, the BIOS should automatically detect your CD-ROM/DVD drive. If it doesn't, enter the Setup Utility and configure the CD-ROM/DVD drive that you have installed. On the mainboard, locate the 4-pin connectors **CD1**.

Pin	Signal
1	CD IN L
2	GND
3	GND
4	CD IN R

## Expansion Slots

This mainboard has one CNR and two 32-bit PCI slots.

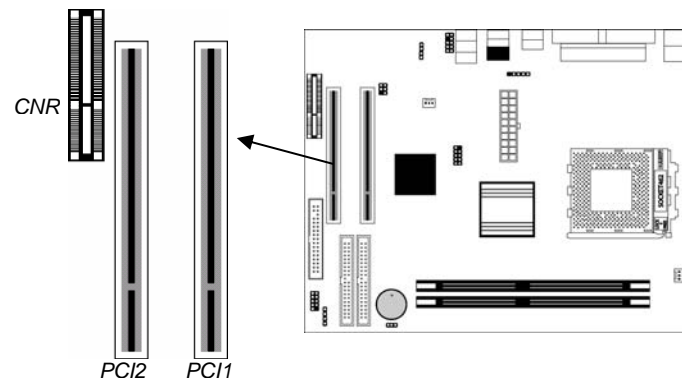

Follow the steps below to install a CNR/PCI expansion card.

1. Locate the CNR or PCI slots on the mainboard.
2. Remove the blanking plate of the slot from the system chassis.
3. Install the edge connector of the expansion card into the slot.  
Ensure the edge connector is correctly seated in the slot.
4. Secure the metal bracket of the card to the system chassis with a screw.

## Chapter 3

# BIOS Setup Utility

---

### Introduction

The BIOS Setup Utility records settings and information of your computer, such as date and time, the type of hardware installed, and various configuration settings. Your computer applies the information to initialize all the components when booting up and basic functions of coordination between system components.

If the Setup Utility configuration is incorrect, it may cause the system to malfunction. It can even stop your computer booting properly. If it happens, you can use the clear CMOS jumper to clear the CMOS memory which has stored the configuration information; or you can hold down the **Page Up** key while rebooting your computer. Holding down the **Page Up** key also clears the setup information.

You can run the setup utility and manually change the configuration. You might need to do this to configure some hardware installed in or connected to the mainboard, such as the CPU, system memory, disk drives, etc.

## Running the Setup Utility

Every time you start your computer, a message appears on the screen before the operating system loading that prompts you to “Hit <DEL> if you want to run SETUP”. Whenever you see this message, press the **Delete** key, and the Main menu page of the Setup Utility appears on your monitor.

AMIBIOS SIMPLE SETUP UTILITY – VERSION 1.21.12  
(C) 2000 American Megatrends, Inc. All Rights Reserved

Standard CMOS Setup	Features Setup
Advanced Setup	CPU PnP Setup
Power Management Setup	Hardware Monitor
PCI / Plug and Play Setup	Change Password
Load Optimal Settings	Exit
Load Best Performance Settings	
Esc : Quit    ↑ ↓ ← →: Select Item (Shift)F2 : Change Color    F5 : Old Values F6 : Optimal values                      F7 : Best performance values    F10 : Save&Exit	
Standards CMOS setup for changing time, date, hard disk type, etc.	

You can use the cursor arrow keys to highlight any of the options on the main menu page. Press **Enter** to select the highlighted option. To leave the setup utility, press the **Escape** key. To cycle through the Setup Utility’s optional color schemes hold down the **Shift** key and press **F2**.

Some of the options on the main menu page lead to tables of items with installed values. In these pages, use the cursor arrow keys to highlight the items, and then use the **PgUp** and **PgDn** keys to cycle through the alternate values for each of the items. Other options on the main menu page lead to dialog boxes requiring you to answer Yes or No by hitting the **Y** or **N** keys.

If you have already made changes to the setup utility, press **F10** to save those changes and exit the utility. Press **F5** to reset the changes to the original values. Press **F6** to install the setup utility with a set of default values. Press **F7** to install the setup utility with a set of high-performance values.



## Standard CMOS Setup Page

Use this page to set basic information such as the date, the time, the IDE devices, and the diskette drives. If you press the F3 key, the system will automatically detect and configure the hard disks on the IDE channels.

AMIBIOS SETUP - STANDARD CMOS SETUP										
(C) 2000 American Megatrends, Inc. All Rights Reserved										
Date (mm/dd/yy) : Thu Apr 10, 2003										
Time (hh/mm/ss) : 18:06:57										
	Type	Size	Cyln	Head	WPcom	Sec	LBA Mode	Blk Mode	PIO Mode	32Bit Mode
Pri Master	: Auto									On
Pri Slave	: Auto									On
Sec Master	: Auto									On
Sec Slave	: Auto									On
Floppy Drive A : 1.44 MB 31/2										
Floppy Drive B : Not Installed										
Month : Jan - Dec					ESC : Exit					
Day : 01 - 31					↑↓ : Select Item					
Year : 1901 - 2099					PU/PD/+/- : Modify					
					(Shift)F2 : Color					
					F3 : Detect All HDD					

Date & Time	Use these items to set the system date and time
Pri Master Pri Slave Sec Master Sec Slave	Use these items to configure devices connected to the Primary and Secondary IDE channels. To configure an IDE hard disk drive, choose <i>Auto</i> . If the <i>Auto</i> setting fails to find a hard disk drive, set it to <i>User</i> , and then fill in the hard disk characteristics (Size, Cyls, etc.) manually. If you have a CD-ROM drive, select the setting <i>CDROM</i> . If you have an ATAPI device with removable media (e.g. a ZIP drive or an LS-120) select <i>Floptical</i> .
Floppy Drive A Floppy Drive B	Use these items to set the size and capacity of the floppy diskette drive(s) installed in the system.

## Advanced Setup Page

Use this page to set more advanced information about your system. Take some care with this page. Making changes can affect the operation of your computer.

AMIBIOS SETUP – ADVANCED SETUP		
(C) 2000 American Megatrends, Inc. All Rights Reserved		
Shared Memory Size	32 MB	
Quick Boot	Enabled	
1 <sup>st</sup> Boot Device	IDE-0	
2 <sup>nd</sup> Boot Device	Floppy	
3 <sup>rd</sup> Boot Device	CDROM	
Try Other Boot Devices	Yes	
S.M.A.R.T. for Hard Disks	Disabled	
BootUp Num-Lock	On	ESC : Quit      ↑↓←→ : Select Item
Floppy Drive Swap	Disabled	F1 : Help      PU/PD/+/- : Modify
Floppy Drive Seek	Disabled	F5 : Old Values (Shift)F2 : Color
Password Check	Setup	F6 : Load BIOS Defaults
Boot To OS/2 > 64MB	No	F7 : Load Setup Defaults
L2 Cache	WriteBack	
System BIOS Cacheable	Enabled	
Graphic Win Size	64MB	
DRAM CAS# Latency	3T	
Timing Setting Mode	Normal	
Auto Detect DIMM/PCI Clk	Enabled	
Spread Spectrum	Disabled	

<b>Share Memory Size</b>	This item lets you allocate a portion of the main memory for the onboard VGA display application with 16/32/64MB options.
<b>Quick Boot</b>	If you enable this item, the system starts up more quickly by elimination some of the power on test routines.
<b>1<sup>st</sup> Boot Device</b> <b>2<sup>nd</sup> Boot Device</b> <b>3<sup>rd</sup> Boot Device</b>	Use these items to determine the device order the computer uses to look for an operating system to load at start-up time.
<b>Try Other Boot Devices</b>	If you enable this item, the system will also search for other boot devices if it fails to find an operating system from the first two locations.

S.M.A.R.T. for Hard Disks	Enable this item if any IDE hard disks support the S.M.A.R.T. (Self-Monitoring, Analysis and Reporting Technology) feature.
BootUp Num-Lock	This item determines if the Num Lock key is active or inactive at system start-up time.
Floppy Drive Swap	If you have two diskette drives installed and you enable this item, drive A becomes drive B and drive B becomes drive A.
Floppy Drive Seek	If you enable this item, your system will check all floppy disk drives at start up. Disable this item unless you are using an old 360KB drive.
Password Check	If you have entered a password for the system, use this item to determine if the password is required to enter the Setup Utility ( <i>Setup</i> ) or required both at start-up and to enter the Setup Utility ( <i>Always</i> ).
Boot to OS/2 > 64MB	Enable this item if you are booting the OS/2 operating system and you have more than 64MB of system memory installed.
L2 Cache	Leave these items enabled since all the processors that can be installed on this board have internal L2 cache memory.
System BIOS Cacheable	If you enable this item, a segment of the system BIOS will be cached to main memory for faster execution.
Graphic Win Size	This item defines the size of aperture if you use a graphic adapter.
DRAM CAS# Latency	This item determines the operation of the DRAM memory CAS (column address strobe). We recommend that you leave this item at the default value. The 2T setting requires faster memory that specifically supports this mode.
Timing Setting Mode	This item determines the timing setting mode of the memory. We recommend you leave this item at the default value.

Auto Detect DIMM/PCI Clk	Use this item to enable the DIMMs or PCI slots to detect automatically device then generating clock.
Spread Spectrum	If you enable spread spectrum, it can significantly reduce the EMI(Electro-Magnetic Interference) generated by the system.

## Power Management Setup Page

This page sets some of the parameters for system power management operation.

AMIBIOS SETUP – POWER MANAGEMENT SETUP (C) 2000 American Megatrends, Inc. All Rights Reserved		
ACPI Aware O/S	Yes	ESC : Quit      ↑↓←→ : Select Item F1 : Help        PU/PD/+/- : Modify F5 : Old Values (Shift)F2 : Color F6 : Load BIOS Defaults F7 : Load Setup Defaults
Power Management	Enabled	
Suspend Time Out	Disabled	
Hard Disk Time Out	Disabled	
Resume On RTC Alarm	Disabled	
RTC Alarm Date	15	
RTC Alarm Hour	12	
RTC Alarm Minute	30	
RTC Alarm Second	00	
LAN/Ring Power On	Disabled	
Keyboard Power On	Disabled	

ACPI Aware O/S	Enable this item if you are using an O/S that supports ACPI function such as Windows 98/ME /2000.
Power Management	Use this item to select a power management scheme. Both APM and ACPI are supported.
Suspend Time Out	This sets the timeout for Suspend mode in minutes. If the time selected passes without any system activity, the computer will enter power-saving Suspend mode.
Hard Disk Time Out	This sets the timeout to power down the hard disk drive, if the time selected passes without any hard disk activity.

Resume On RTC Alarm / Date / Hour / Minute / Second	The system can be turned off with a software command. If you enable this item, the system can automatically resume at a fixed time based on the system's RTC (realtime clock). Use the items below this one to set the date and time of the wake-up alarm. You must use an ATX power supply in order to use this feature.
LAN/Ring Power On	Your system can enter a software power down. If you enable this item, the system can automatically resume if there is traffic on the network adapter.
Keyboard Power On	If you enable this item, you can turn the system on and off by pressing hot keys on the keyboard. You must enable the Keyboard Power On jumper and use an ATX power supply in order to use this feature.

## PCI / Plug and Play Setup Page

This page sets some of the parameters for devices installed on the PCI bus and devices that use the system plug and play capability.

AMIBIOS SETUP – PCI / PLUG AND PLAY SETUP (C) 2000 American Megatrends, Inc. All Rights Reserved	
Plug and Play Aware O/S	Yes
Primary Graphics Adapter	PCI
Allocate IRQ to PCI VGA	Yes
PCI IDE BusMaster	Disabled
ESC : Quit      ↑↓←→ : Select Item F1 : Help      PU/PD/+/- : Modify F5 : Old Values (Shift)F2 : Color F6 : Load BIOS Defaults F7 : Load Setup Defaults	

Plug and Play Aware O/S	Enable this item if you are using an O/S that supports Plug and Play such as Windows 95/98/ME.
-------------------------	--

Primary Graphics Adapter	This item indicates if the primary graphics adapter uses the PCI or the AGP bus. The default PCI setting still lets the onboard display work and allows the use of a second display card installed in a PCI slot.
Allocate IRQ to PCI VGA	If this item is enabled, an IRQ will be assigned to the PCI VGA graphics system. You set this value to No to free up an IRQ.
PCI IDE BusMaster	This item enables or disables the DMA under DOS mode. We recommend you to leave this item at the default value.

### Load Optimal Settings

If you select this item and press **Enter** a dialog box appears. If you press **Y**, and then **Enter**, the Setup Utility loads a set of fail-safe default values. These default values are not very demanding and they should allow your system to function with most kinds of hardware and memory chips.

**Note: It is highly recommended that users enter this option to load optimal values for accessing the best performance.**

### Load Best Performance Settings

If you select this item and press **Enter** a dialog box appears. If you press **Y**, and then **Enter**, the Setup Utility loads a set of best-performance default values. These default values are quite demanding and your system might not function properly if you are using slower memory chips or other low-performance components.

## Features Setup Page

This page sets some of the parameters for peripheral devices connected to the system.

AMBIOS SETUP – FEATURES SETUP		
(C) 2000 American Megatrends, Inc. All Rights Reserved		
OnBoard FDC	Enabled	
OnBoard Serial PortA	3F8h/COM1	
OnBoard IR Port	Disabled	
OnBoard Parallel Port	378h	
Parallel Port Mode	ECP	
Parallel Port IRQ	7	
Parallel Port DMA	3	
OnBoard PCI IDE	Both	ESC : Quit      ↑↓←→ : Select Item
Audio Device	Enabled	F1 : Help      PU/PD/+/- : Modify
Modem Device	Enabled	F5 : Old Values (Shift)F2 : Color
Ethernet Device	Enabled	F6 : Load BIOS Defaults
USB Function Support	Enabled	F7 : Load Setup Defaults
USB Function for DOS	Disabled	
ThumbDrive for DOS	Disabled	

OnBoard FDC	Use this item to enable or disable the onboard floppy disk drive interface.
OnBoard Serial PortA	Use these items to enable or disable the onboard COM1/2 serial port, and to assign a port address.
OnBoard Ir Port	Use this item to define the protocol for an infrared port if you have installed an optional IR port. The options are IrDA and ASKIR.
Onboard Parallel Port	Use this item to enable or disable the onboard LPT1 parallel port, and to assign a port address. The Auto setting will detect and available address.
Parallel Port Mode	Use this item to set the parallel port mode. You can select SPP (Standard Parallel Port), ECP (Extended Capabilities Port), EPP (Enhanced Parallel Port), or ECP + EPP.
Parallel Port IRQ	Use this item to assign either IRQ 5 or 7 to the parallel port.

Parallel Port DMA	Use this item to assign a DMA channel to the parallel port. The options are 0, 1 and 3.
Onboard PCI IDE	Use this item to enable or disable either or both of the onboard Primary and Secondary IDE channels.
Audio Device	This item enables or disables the onboard AC'97 audio chip.
Modem Device	This item enables or disables the onboard AC'97 modem chip.
Ethernet Device	This item enables or disables the LAN chip.
USB Function Support	Enable this item if you plan to use the USB ports on this mainboard.
USB Function for DOS	Enable this item if you plan to use the USB ports on this mainboard in a DOS environment.
ThumbDrive for DOS	Enable this item to make a small portion of memory storage device for the USB ports.



## CPU PnP Setup Page

This page lets you manually configure the mainboard for the CPU. The system will automatically detect the kind of CPU that you have installed and make the appropriate adjustments to the items on this page.

AMIBIOS SETUP – CPU PnP SETUP		
©2000 American Megatrends, Inc. All Rights Reserved		
CPU Speed	100/100 MHz	
CPU Frequency	100 MHz	
DRAM Frequency	100 MHz	
		ESC : Quit      ↑↓←→ : Select Item F1 : Help        PU/PD/+- : Modify F5 : Old Values (Shift)F2 : Color F6 : Load Optimal values F7 : Load Best performance values

---

CPU Speed	Use this item to set the CPU speed that has installed in your system.
CPU/DRAM Frequency	Use this item to set the frequency of CPU/DRAM that has installed in your system.

---

**Note:** If you manually set the wrong speed and the system won't run properly, press the **Page Up** key while the system is booting and a default setting will replace the incorrect CPU setting.

## Hardware Monitor Page

This page sets some of the parameters for the hardware monitoring function of this mainboard.

AMIBIOS SETUP – HARDWARE MONITOR		
(C) 2000 American Megatrends, Inc. All Rights Reserved		
*** System Hardware ***		
Vcore	1.616V	ESC : Quit      ↑↓←→ : Select Item F1 : Help        PU/PD/+/- : Modify F5 : Old Values (Shift)F2 : Color F6 : Load BIOS Defaults F7 : Load Setup Defaults
Vcc 2.5V	2.496V	
Vcc 3.3V	3.392V	
Vcc	4.945V	
+12V	12.032V	
SB3V	3.472V	
SB5V	5.026V	
VBAT	3.472V	
SYSTEM Fan Speed	0 RPM	
CPU Fan Speed	1308 RPM	
SYSTEM Temperature	31°C/87°F	
CPU Temperature	39°C/102°F	

Voltage Measurements & FAN Speeds	These items indicate cooling fan speeds in RPM and the various system voltage measurements.
System / CPU Temperature	These items display CPU and system temperature measurement.

## Change Password

If you highlight this item and press **Enter**, a dialog box appears which lets you enter a Supervisor password. You can enter no more than six letters or numbers. Press **Enter** after you have typed in the password. A second dialog box asks you to retype the password for confirmation. Press **Enter** after you have retyped it correctly. The password is then required to access the Setup Utility or for that and at start-up, depending on the setting of the Password Check item in Advanced Setup.

### **Change or Remove the Password**

Highlight this item, press **Enter** and type in the current password. At the next dialog box, type in the new password, or just press **Enter** to disable password protection.

### **Exit**

Highlight this item and press **Enter** to save the changes that you have made in the Setup Utility configuration and exit the program. When the Save and Exit dialog box appears, press **Y** to save and exit, or press **N** to exit without saving.

## Chapter 4

# Software & Applications

---

### Introduction

This chapter describes the contents of the support CD-ROM that comes with the mainboard package.

The support CD-ROM contains all useful software, necessary drivers and utility programs to properly run our products. More program information is available in a README file, located in the same directory as the software.

To run the support CD, simply insert the CD into your CD-ROM drive. An Auto Setup screen automatically pops out, and then you can go on the auto-installing or manual installation depending on your operating system.

If your operating system is Windows 98/ME/2000/XP, it will automatically install all the drivers and utilities for your mainboard; if Windows NT or manual installation, please follow the instructions described as the Installing under Windows NT or Manual Installation section.

## Installing Support Software

1. Insert the support CD-ROM disc in the CD-ROM drive.
2. When you insert the CD-ROM disc in the system CD-ROM drive, the CD automatically displays an Auto Setup screen.
3. The screen displays three buttons of **Setup**, **Browse CD** and **Exit** on the right side, and three others **Setup**, **Application** and **ReadMe** at the bottom. Please see the following illustration.



The **Setup** button runs the software auto-installing program as explained in next section.

The **Browse CD** button is a standard Windows command that you can check the contents of the disc with the Windows 98 file browsing interface.

The **Exit** button closes the Auto Setup window. To run the program again, reinsert the CD-ROM disc in the drive; or click the CD-ROM driver from the Windows Explorer, and click the Setup icon.

The **Application** button brings up a software menu. It shows the bundled software that this mainboard supports.

The **ReadMe** brings you to the Install Path where you can find out path names of software driver.

## Auto-Installing under Windows 98/ME/2000/XP

If you are under Windows 98/ME/2000/XP, please click the **Setup** button to run the software auto-installing program while the Auto Setup screen pops out after inserting the support CD-ROM:

1. The installation program loads and displays the following screen. Click the **Next** button.



2. Select the items that you want to setup by clicking on it (the default options are recommended). Click the **Next** button to proceed.

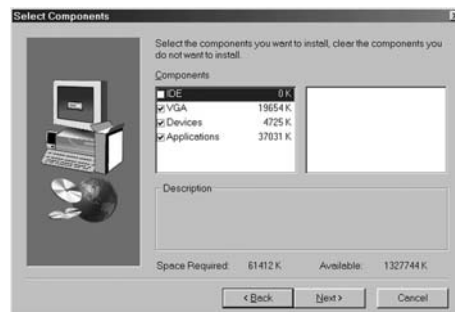

3. The support software will automatically install.

Once any of the installation procedures start, software is automatically installed in sequence. You need to follow the onscreen instructions, confirm commands and allow the computer to restart as few times as needed to complete installing whatever software you selected. When the process is finished, all the support software will be installed and start working.

### **Installing under Windows NT or Manual Installation**

If you are under Windows NT, the auto-installing program doesn't work out; or you have to do the manual installation, please follow this procedure while the Auto Setup screen pops out after inserting the support CD-ROM:

1. Click the **ReadMe** to bring up a screen, and then click the **Install Path** at the bottom of the screen.
2. Find out your mainboard model name and click on it to obtain its correct driver directory.
3. Install each software in accordance with the corresponding driver path.

### **Bundled Software Installation**

All bundled software available on the CD-ROM is for users' convenience. You can install bundled software as follows:

1. Click the **Application** button while the Auto Setup screen pops out after inserting the support CD-ROM.
2. A software menu appears. Click the software you want to install.
3. Follow onscreen instructions to install the software program step by step until finished.