

# molbloc™ / molbox™

## Gas Flow Standards



Calibration Solutions  
for Pressure and Flow™

# molbloc™ / molbox™

## Flow Calibration System

### INTRODUCTION...

#### TABLE OF CONTENTS

• INTRODUCTION	1
• GENERAL FEATURES	3
• PUTTING TOGETHER A molbloc/molbox FLOW CALIBRATION SYSTEM	8
• molbox FLOW TERMINALS	10
• molbloc LAMINAR FLOW ELEMENTS	13
• SPECIFICATIONS	17

In the early 1990s, **DHI** recognized the growing need for a new calibration tool for low gas flows. To support increasing requirements for lower measurement uncertainties and documented traceability of flow measurements at the process level, a transfer standard combining high performance with portability and ease of use was needed. **DHI** developed the **molbloc/molbox** flow calibration system in response to this need. Based on a new, patented, laminar flow element design, and applying today's modern measuring, mathematical modeling, data processing and manufacturing techniques, **molbloc/molbox** introduced a new level of performance and convenience in low flow standards. **molbloc/molbox** has rapidly gained wide acceptance in a variety of fields --- semiconductors, fiber optics, pharmaceuticals, environmental monitoring, energy production, reference gas blending, research and standards laboratories --- as the reference of choice in assuring the integrity of low flow measurements.

**molbloc/molbox** covers the flow range from less than 1 sccm to more than 100 slm with accuracy to  $\pm 0.2\%$  of reading in a variety of gases. A 1 second update rate makes real time measurement and test instrument adjustment with a true flow standard possible for the first time. Compact and readily transportable, **molbloc/molbox** can be operated locally from the full feature front panel or remotely over its RS232 and IEEE-488 interfaces.

**molbloc/molbox** configurations and accessories support a wide variety of flow testing and measurement applications. **molbloc/molbox** can be integrated into systems for on-line checking of process instruments, easily transported for use as an on-site audit or check standard and combined with accessories to set up a complete, automated flow calibration bench. **molbloc/molbox** systems test and calibrate a wide variety of flow devices including thermal MFCs, rotameters, turbine meters, bubble meters and others.



The pages that follow describe **molbloc/molbox**:

**GENERAL FEATURES:** Pages 3 to 7 describe **molbloc/molbox** technology and summarize some of the important features that make **molbloc/molbox** a unique flow calibration tool.

**PUTTING TOGETHER A molbloc/molbox SYSTEM:** Pages 8 and 9 illustrate some typical **molbloc/molbox** configurations and provide instructions for putting together a **molbloc/molbox** system to fit your specific needs.

**molbox FLOW TERMINALS:** Pages 10 to 12 detail the two molbox flow terminal models available.

**molbloc LAMINAR FLOW ELEMENTS:** Pages 13 to 16 cover the molbloc flow elements and calibration options

available to cover different flow ranges with different gases and pressure requirements.

**SPECIFICATIONS:** Pages 17 and 18 list complete **molbloc/molbox** technical specifications.

Though you'll find this catalog goes well beyond traditional commercial literature in its efforts to inform you... everything about **molbloc/molbox** and how it can benefit your flow measurements cannot be included here. For additional **molbloc/molbox** assistance, or information on **DHI's other flow and pressure calibration products** and services, please contact **DHI** or your local representative. You can count on our commitment to objectively analyze your needs and recommend the best solutions to meet them.

## molbloc™ Laminar Flow Element

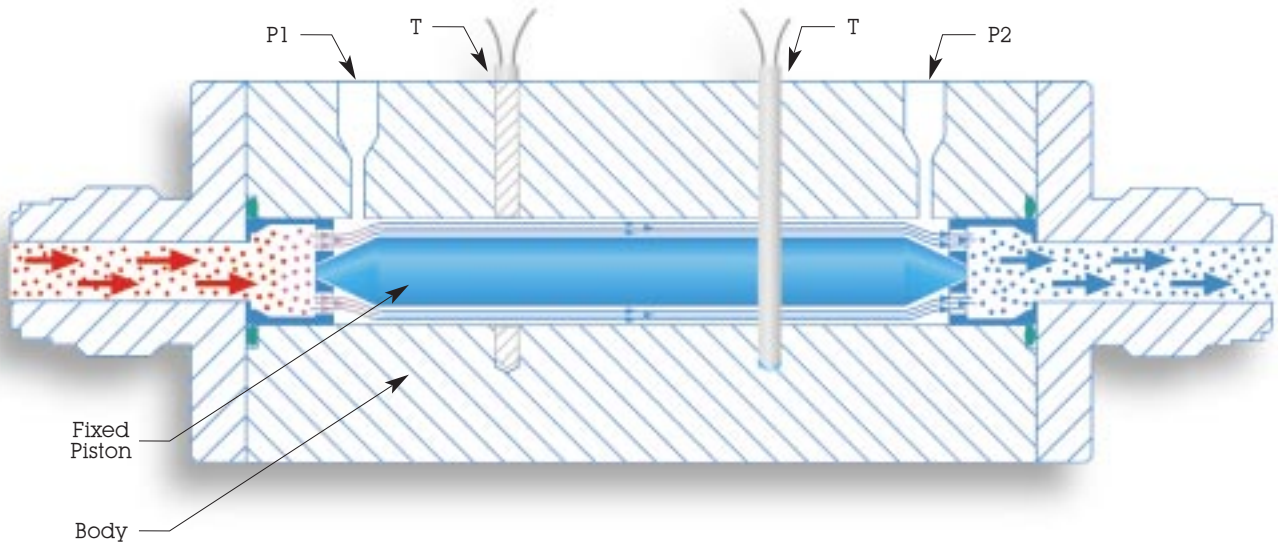

$$qm = \frac{(P_1 - P_2) \rho_{(P,T)}}{\eta_{(P,T)}} \cdot C_{G(Re)}$$

where:

$$\rho_{(P,T)} = \frac{P \cdot M}{Z_{(P,T)} \cdot R \cdot T}$$

$$Re = \frac{qm}{\pi r \cdot \eta_{(P,T)}}$$

Determined by  
Measurement

$P_1$   
 $P_2$   
 $T$

Known from  
Gas Properties

$M$   
 $Z_{(P,T)}$   
 $\eta_{(P,T)}$

Determined from  
Gravimetric Calibration

$C_G$

See p. 16 for  
List of Symbols.

# molbloc™ / molbox™

## General Features...

### FOUNDED ON PROVEN LAWS OF GAS BEHAVIOR

The molbloc/molbox flow measurement principle follows established laminar flow theory. In accordance with well known laws of gas behavior, the flow of a known gas in the laminar flow regime can be calculated from the flow path geometry and the gas pressure and temperature (see molbloc flow equation on previous page).

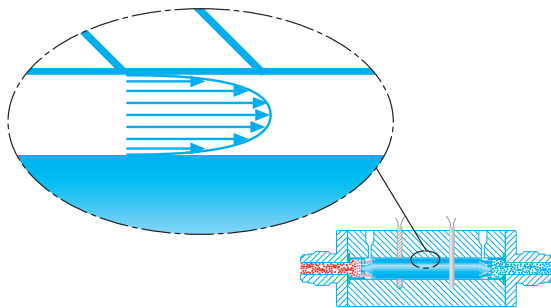

Parabolic Gas Velocity Distribution in Laminar Flow

molbloc/molbox achieves unprecedented levels of stability and precision from the laminar flow principle by applying today's modern sensor, mathematical modeling and data processing technologies to a flow element design so novel it has been granted US and international patent protection. This combination improves knowledge of gas pressure and temperature, provides a better definition of flow path and allows comprehensive, real time flow calculation using the thermodynamic properties of the gas under actual flowing conditions.

### ADVANCED PRESSURE AND TEMPERATURE MEASUREMENT TECHNOLOGY

The uncertainty in flow measurements based on the laminar flow principle is very highly dependent on differential pressure, gas density and viscosity, and therefore the uncertainty in the pressure and temperature of the flowing gas. molbloc/molbox breaks new ground in gas pressure and temperature measurement.

3

The pressure of the gas upstream ( $P_1$ ) and downstream ( $P_2$ ) of the molbloc flow element is picked off from pressure stabilization chambers and measured by two absolute pressure transducers

located in the molbox flow terminal. In molbox1, the transducers employ state of the art, crystal oscillator technology providing 1 ppm resolution and  $\pm 0.01\%$  per year stability. The upstream and downstream transducer readings are averaged to determine the absolute gas pressure. The difference between the two pressure readings provides the

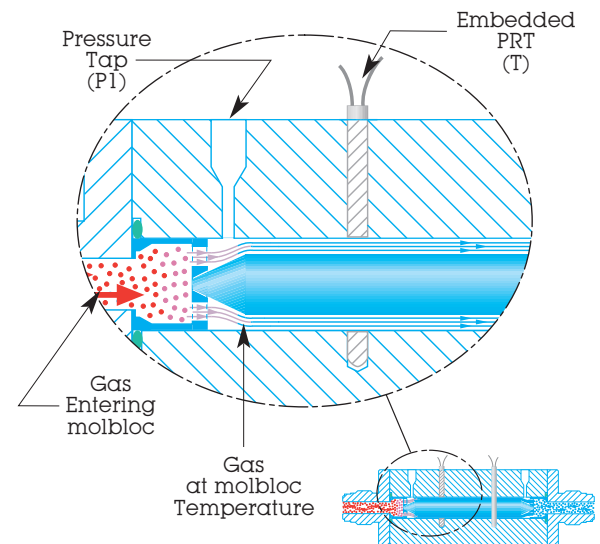

molbloc Gas Pressure and Temperature Measurement

differential pressure across the molbloc. Internal molbox valving and an automated "tare" function allow the two transducers' differential measurement to be autozeroed at any time, independently of current flow conditions.

A patented design greatly improves the determination of the temperature of the gas flowing through the molbloc flow element. Rather than attempting to measure the temperature of the gas entering or exiting the flow element with a probe, the gas is forced to the temperature of the molbloc body and the molbloc body temperature is measured. The large thermal mass of the molbloc body and the very large metal-to-gas contact surface created by molbloc's annular flow path cause the gas to take on the molbloc's temperature. An isothermal gas expansion occurs as gas flows through the molbloc. The temperature of the isotherm is determined by measuring the molbloc body temperature. The molbloc body temperature is measured very precisely using two platinum resistance thermometers (PRT) embedded symmetrically in the molbloc body. The PRTs are read by an ohmic measurement system in the molbox



that self-calibrates with on-board reference resistors. This combination allows the temperature of the gas flowing through the molbloc to be known within better than  $\pm 0.1$  °C.

## SUPERIOR STABILITY OVER TIME

The role of a transfer standard is to reliably transfer reference values from primary standards to other devices. In filling this role, the transfer standard's single most important characteristic is stability over time. The stability over time of a molbloc/molbox system is dependent on three parameters: a) the molbloc's laminar **flow path geometry**; b) the gas **pressure measurement**; and c) the gas **temperature measurement**. The stability specification for a molbox1 based molbloc/molbox system is  $\pm 0.1$  % of reading per year. This is made possible, with a considerable safety margin, by the fundamental mechanical stability of the molbloc flow path and pressure and temperature measurements that exceed the specification.

The molbloc's laminar flow path is the space between the molbloc body's central bore and the molbloc piston. The path is defined using just two solid, stainless steel parts. In high range molblobs, the piston is held rigidly in the cylinder by a patented holding system based on symmetrical elastic deformation of the centering holders. In lower range molblobs, in which the gap is quite small and even very small movement of the piston could alter the flow path significantly, the piston is held by interference fit with the cylinder. The flow path geometry is designed so that the gas passes straight through a simple shape minimizing opportunities for contaminants to collect. All wetted surfaces are electropolished to a  $0.15 \mu$  Ra finish to avoid particle collection from the flowing gas.

Every molbox has identical upstream and downstream pressure transducers. In molbox1, these provide stability of  $\pm 0.01$  % per year. Each time the pressure transducers are zeroed differentially, they are also compared one to the other and the user is alerted to disagreements that may indicate excessive drift.

The platinum resistance thermometers (PRTs) that measure molbloc temperature are read by the molbox's ohmic measurement system. At each molbox power up, an automated routine calibrates the ohmic

measurement system against on-board, reference resistors with three year stability of  $\pm 0.005$  %. This combination provides temperature reading stability of better than  $\pm 0.01$  % per year. As a precaution against damage or malfunction, the temperature readings of the two PRTs are also regularly compared to each other to identify excessive disagreements.

## OUTSTANDING RANGEABILITY

molbloc/molbox's very high rangeability makes it particularly effective when configuring a system to cover a wide range of devices to be calibrated. molbloc/molbox's flow measurement uncertainty is **relative to the flow reading, not the molbloc full scale**. Since the typical device to be calibrated has measurement uncertainty that is **relative to its full scale**, one range of molbloc can be used to calibrate a wide range of devices. For example, a 5 slm molbloc used with molbox1 to calibrate  $\pm 1$  % FS devices has a 5:1, or better, measurement accuracy ratio with any device whose range is between 500 sccm and 5 slm. With molbox RFM,  $\pm 0.5$  % **of reading** measurement uncertainty from 1 sccm to 10 slm can be achieved using only two molblobs.

molbloc/molbox's rangeability reduces system complexity and original cost as well as on-going recalibration costs.

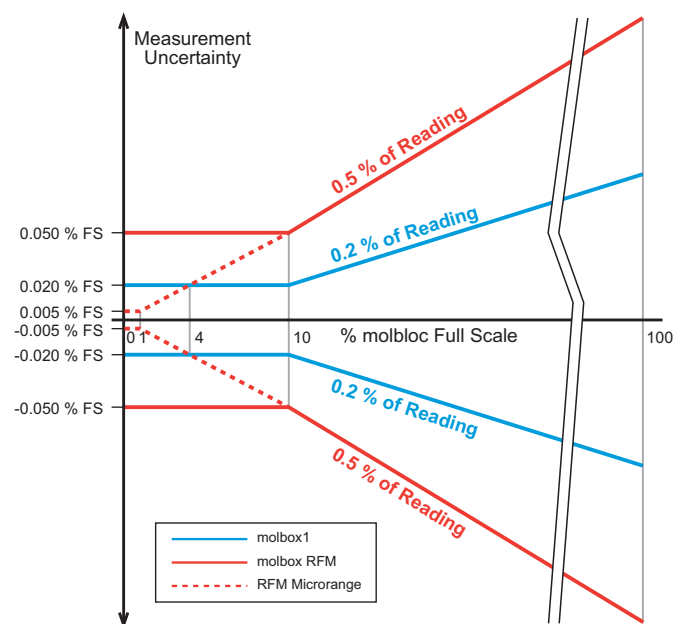

molbloc Flow Measurement Uncertainty

## CONTINUOUS, REAL TIME READING

The mass flow through a laminar flow element at any moment in time is directly proportional to the pressure drop across the element. Unlike systems based on rate of volume or rate of pressure change, the measurement of flow through a laminar element is not time based. This allows molbloc/molbox to deliver flow readings as frequently as once per second with the system's full precision and minimum uncertainty.

Real time reading makes it possible to collect test or calibration data without having to wait for measurement cycles to complete or reset. Real time reading provides instantaneous feedback on the effect of adjustments made to a device under test. Real time reading also allows molbloc/molbox to be used in active measurement applications such as blending reference gas mixes.

The laminar flow element's continuous, uninterrupted reading capability makes it the ideal standard for checking or calibrating flow totalizing devices. molbloc/molbox can measure total flow, without interruption, over any time period.

## MULTIPLE GAS SUPPORT

molbloc/molbox can measure the flow of a wide variety of gases. These include the common inert gases as well as a variety of industrial process and calibration surrogate gases.

The complete thermodynamic properties unique to each gas are stored in molbox non-volatile memory. These are recalled and applied when the gas is selected. The gas selection can be made directly, at any time, from the molbox front panel or by remote command. An automated purge function clears the old gas from the molbox pneumatic circuit when using a new gas.

## ADVANCED ON BOARD FUNCTIONS

To complement its basic flow measuring capability and maximize the system's utility, molbox supports a wide range of functions and special features. These include operational features such as:

- Measure and display in 28 different units of mass and volume flow including user define units
- Select from more than 18 different gases

- Real time molbloc pressure and temperature displays
- Adjustable display resolution
- Full time, stability dependent, ready/not ready indication
- Automated purge routine for changing gases
- Intelligent internal and external leak detection routines
- Overpressure monitoring and self defense system

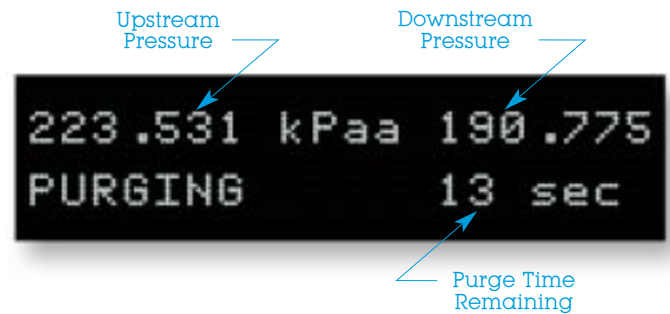

molbox Purging Function Display

Also included are advanced functions such as:

- Averaging over time with adjustable time period and standard deviation calculation
- Hi/Lo monitoring
- Flow totalizing with adjustable time period
- Simultaneous display in two different flow units of measure
- MFC control and measurement with flow and % FS conversions (molbox1 option only)
- Password protected data security

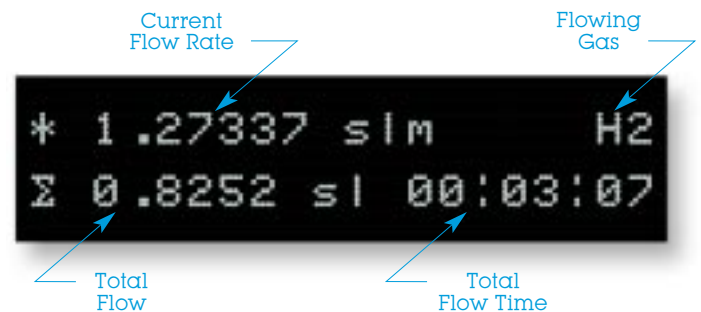

Flow Totalizer Function Display

As molbox's embedded software is stored in FLASH memory, keeping molbox current with all the latest features is easy and cost free. Periodic software improvements and upgrades are placed on **DHI's** world wide web site ([www.dhainstruments.com](http://www.dhainstruments.com)) and can be downloaded and installed by the user at no charge.

## STANDARD COMMUNICATIONS INTERFACES

Every molbox includes RS232 and IEEE-488 interfaces for communication with a host computer. A second RS232 port (COM2) is included for pass through communication with another RS232 device.

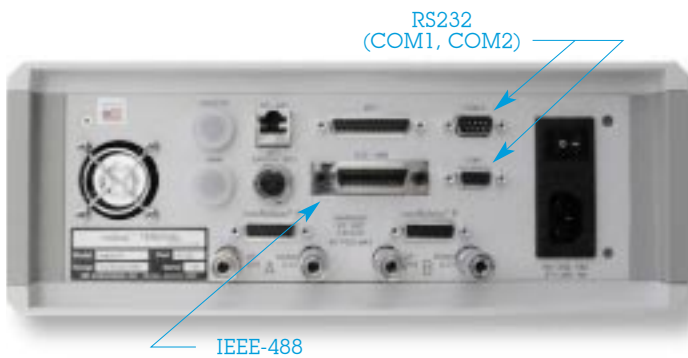

Rear Panel Interface Connections

The interfaces are supported by a complete set of ASCII command strings allowing all molbox measurements and functions to be accessed remotely. All aspects of interfacing protocol and commands are thoroughly documented in the molbox Operation and Maintenance Manual.

LabVIEW® drivers are available at no charge as program building blocks for National Instruments LabVIEW users.

## TRACEABLE ACCURACY SUPPORTED BY PRIMARY GRAVIMETRIC STANDARDS

molbloc/molbox has the precision and stability over time required to be an excellent transfer standard. To meet its full potential as a calibration tool, it must be calibrated with primary standards traceable to national and international standards.

molbloc/molbox's continuous reading capability and very high stability over time, allow it to be calibrated using the only method that derives mass flow directly from the base units of mass and time. In this method, called gravimetric, the amount of gas flowed over a period of time is weighed so its mass is known directly with no dependence on the imperfect knowledge of the gas's thermodynamic properties. With the gravimetric method, in exact agreement with the definition of a primary standard, the uncertainty on mass flow is dependent only on the

direct measurement of the base units of mass and time from which mass flow is derived.

**DHI** has developed a complete gravimetric calibration facility dedicated to molbloc/molbox calibration. The calibration system is maintained by the **DHI** metrology service and documented in a formal quality assurance program with a detailed uncertainty analysis. To further increase confidence and guarantee homogeneity of measurements, flow intercomparisons are regularly performed with a variety of primary methods in other mass flow metrology laboratories. The **DHI** calibration system is used to calibrate every molbloc and each one is delivered with a complete calibration report documenting traceability to the United States National Institute of Standards and Technology (NIST) and including specific measurement results.



Gravimetric Calibration

## RECALIBRATION OPTIONS

The recommended recalibration interval for a molbloc/molbox system is one year. The one year interval is not a reflection of the intrinsic stability of the system which, without incident, should hold its specifications much longer. One year is recommended as a precaution considering variations in conditions of use from application to application and the central role that molbloc/molbox usually plays in the user's flow measurement system. After the first two annual recalibrations, an analysis of the results may justify extending recalibration interval.

There are two aspects to recalibrating a molbloc/molbox system. One is the calibration of the pressure transducers in the molbox, the other is the verification of the stability of the laminar flow path of the molbloc. These can be conducted independently one from the other.

Calibration of the molbox pressure transducers is a routine procedure for any facility with high accuracy pressure calibration capability in the range of atmosphere to 550 kPa absolute (80 psia). Transducer readings can be adjusted to agree with a calibration standard by setting simple calibration coefficients in the molbox. *Note: The molbox RFM microrange option pressure transducer requires a 0 to 10 kPa (1.5 psi gauge) calibration.*

Calibration of the molblocs requires a flow standard with lower measurement uncertainty than that of the molbloc/molbox system. In the original factory calibration, proprietary calibration coefficients which characterize the molbloc flow path are determined. Since molblocs are static mechanical elements in which there is no inherent drift, the original factory coefficients do not change unless the molbloc is damaged or contaminated. For this reason, molblocs that are found out of tolerance in recalibration are generally considered to need repair and are returned to **DHI** for service. Special calibration software is available for facilities that require the capability to adjust molbloc readings to agree with their standards.

### COMPASS® FOR molbox CALIBRATION ASSISTANCE SOFTWARE

COMPASS for molbox calibration assistance software takes molbloc/molbox to the next step in automating calibrations. COMPASS for molbox and a personal computer work with molbloc/molbox to create a modern, full function, turnkey system for calibrating and testing flow devices.

COMPASS sets up device under test (DUT) records, defines and associates test procedures with DUTs, runs tests, acquires reference and test data, produces



COMPASS® for molbox Main Run Screen

standard and custom calibration reports. All reference, DUT and test data are collected and stored in standard delimited files that can be easily downloaded to other applications.

COMPASS is much more than a simple data acquisition and test sequencing tool. It also includes specialized capabilities for data reduction in support of pressure and temperature dependent flow devices such as rotameters, turbine meters and volume meters.

### FROM A SIMPLE REFERENCE FLOW METER TO A COMPLETE CALIBRATION SYSTEM

With a choice of two molbox models and a wide variety of accessories, the exceptional flow measurement capabilities offered by molbloc/molbox can be configured to fit a very wide variety of applications from a simple reference flow meter to a turnkey automated calibration system. molbox RFM and a single molbloc configure a simple, relatively low cost, reference flow meter with measurement uncertainty of  $\pm 0.5\%$  of reading from 1 to 100 % of full scale. molbox1, with the MFC option, molstics and COMPASS software make up a turnkey, fully automated, mass flow calibration bench.

### COMPACT, RUGGED AND TRANSPORTABLE

molbloc/molbox makes a very high performance mass flow standard easily transportable for the first time. A molbox and one or several molblocs can safely be packaged and shipped, or even hand carried, from one location to another. molbloc/molbox can be used as an audit or check standard and as a field standard for on-sight calibration or troubleshooting. Its very high precision and stability also make it an ideal transfer standard for comparing primary standards at different locations.



molbox1 and molblocs Ready for Shipment



## Typical System Configurations...

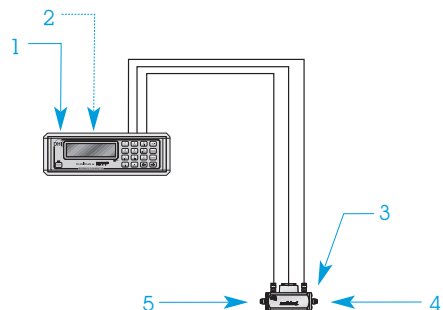

**On-Line Verification of Process Flow Measurement / Control**

1. molbox1 or RFM, mobile or permanently installed
2. Host communications (optional)
3. molbloc, mobile or permanently installed, upstream or downstream of device under test
4. Connection to atmosphere, gas collector or device under test
5. Connection to device under test or gas supply

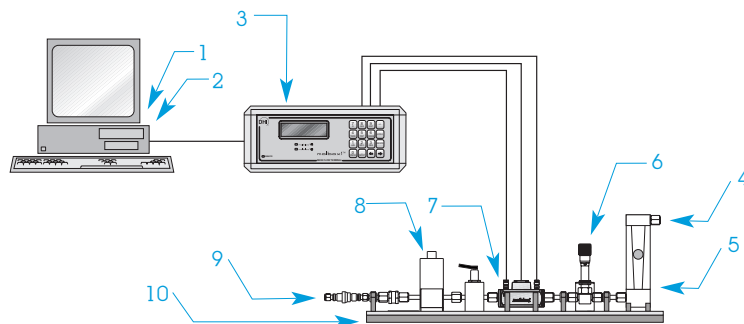

**Test / Calibration of Rotameters or Turbine Flowmeters**

1. Host computer with RS-232 (COM) or IEEE-488 interface
2. COMPASS for molbox, calibration software
3. molbox1 or RFM
4. Atmosphere
5. Device under test, e.g. rotameter or turbine meter
6. Flow adjusting valve
7. molbloc(s)
8. Regulator (molstic)
9. Gas supply
10. molstic, molbloc mounting system

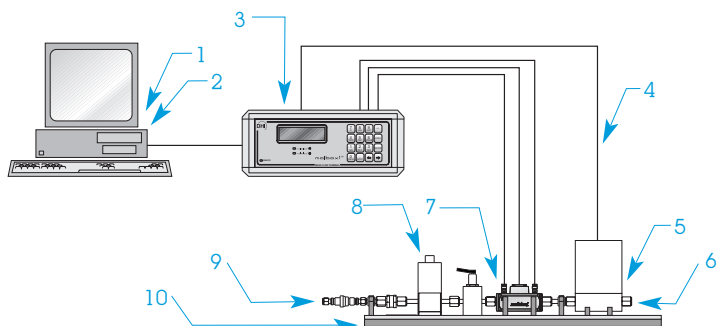

**Test / Calibration of Thermal Mass Flow Controllers (MFCs)**

1. Host computer with RS-232 (COM) or IEEE-488 interface
2. COMPASS for molbox, calibration software
3. molbox1
4. molbox1 MFC control option cable
5. Device under test, MFC
6. Atmosphere or vacuum
7. molbloc(s)
8. Regulator (molstic)
9. Gas supply
10. molstic, molbloc mounting system

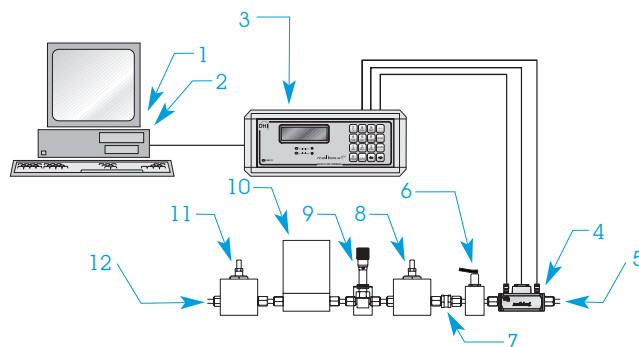

**Test / Calibration of High Pressure Mass Flow Meters (MFM) or MFCs**

1. Host computer with RS-232 (COM) or IEEE-488 interface
2. COMPASS for molbox, calibration software
3. molbox1 or RFM
4. molbloc(s) with downstream calibration
5. Atmosphere
6. Shut-off valve
7. Filter
8. Regulator to protect molbox1 from overpressure
9. Flow adjusting valve (if DUT does not control flow)
10. Device under test, MFM or MFC
11. Pressure regulator to set device under test upstream pressure
12. Gas supply

## Putting Together a System...

The heart of a molbloc/molbox system is the **molbox1™ mass flow terminal**. The molbox performs the data acquisition and processing functions necessary to determine the flow through a molbloc flow element that is connected to it. molbloc™ flow elements of varying flow path size

are available to cover different flow ranges. **molstic™ mounting systems** are offered as an off-the-shelf solution to put the molblobs into service and connect to a device to be tested. **COMPASS® application software** is available to complete a fully automated test system.

To configure a **molbloc/molbox** for your specific requirements, follow the steps below:

### 1. Select molbox or molbox RFM (see pp. 10 to 12)

Choose **molbox1** to:

- **Minimize measurement uncertainty**  
molbox1 uses premium pressure transducers to provide the lowest measurement uncertainty and best stability over time.
- **Set and read analog mass flow controllers (MFCs) with the molbox**  
molbox1 offers an integrated analog MFC control option which sets and reads 0 to 5 V and 4 to 20 mA MFCs.
- **Support two molbloc channels**

Choose **molbox RFM** to:

- **Reduce system cost**
- **Minimize molbox size**
- **Minimize the number of molblobs needed to cover your range (with the microrange™ option)**
- **If you do not need the molbox to set and read analog MFCs**

### 2. Select the molbloc Mass Flow Elements (see pp. 13 to 16)

This includes selecting the molbloc pressure dependent calibration type(s), sizes and special gas calibrations if needed.

#### a) Select one of the three pressure dependent calibration types (see p. 14)

Determine the pressure at which the molbloc must be operated depending on whether it will be upstream or downstream of the device under test

(DUT) and considering the molbloc and DUT differential pressure requirements.

#### b) Select the molbloc size(s) (see tables on pp. 15 and 16)

A molbloc's flow range varies with the molbloc's size, pressure dependent calibration type and the gas flowed. Note that all molblobs measure flow from zero to full scale and their measurement uncertainty is a percent of reading above 10 % full scale (1 % for molbox RFM with the microrange option).

#### c) Select the molbloc special gas calibrations

All molblobs are calibrated with nitrogen (N<sub>2</sub>) but can measure the flow of any molbox supported gas. With non-N<sub>2</sub> gases, for lowest measurement uncertainty and documented traceability, a calibration with the gas must be specified.

### 3. Select One or Several molstic molbloc Mounting Systems (see molstic brochure) If Needed

molstics provide an engineered solution to the practical issues of connecting the molbloc to a regulated gas supply, mounting the molbloc and mounting and connecting to a device under test.

### 4. Select molbloc/molbox Applications Software If Needed

- **COMPASS for molbox** (see COMPASS brochure)  
COMPASS for molbox software works with molbloc/molbox to create a turnkey, full function, automated system for calibrating and testing a wide variety of flow measuring and controlling devices.
- **CalTool for molbloc** (see CalTool brochure)  
CalTool for molbloc software supports "single P" type (see p. 14) user recalibration of molblobs. The molbloc can be adjusted to agree with another flow standard at a specific pressure.

## Flow Terminals...

The molbox is the center of a molbloc/molbox flow calibration system. The molbox performs the functions listed below.

For maximum versatility, two different molbox models are available: **molbox1** and **molbox RFM**. Both use the

same molblobs but provide different measurement uncertainties, size and cost. Generally, molbox1 is oriented towards applications in which minimizing measurement uncertainty and stability over time are the most important requirements. molbox RFM has slightly lower performance but is also lower in cost and more compact.

- **molbloc Pressure and Temperature Measurement**

The molbloc pressure ports are connected by flexible lines with quick connectors to the molbox's pressure transducers. A data cable connects the molbloc platinum resistance thermometers to the molbox's ohmic measurement system and allows the molbox to read the molbloc EEPROM.

- **Pressure Valving System**

Miniature valves inside the molbox support routines to zero the molbox pressure transducers, run automated leak checks and purge when changing gases.

- **Calculation of the Mass Flow Through the molbloc**

The molbox reads molbloc specific calibration coefficients off the molbloc's EEPROM. The complete thermodynamic characteristics of the molbox supported gases are stored in molbox's non-volatile memory. Embedded software uses current pressure and temperature measurements, the characteristics of the flowing gas and molbloc calibration coefficients to

execute the molbloc mass flow equation and provide real time mass flow measurements.

- **Local Operator Interface**

A 4 x 4 keypad and 2 x 20 display provide local user control over molbox operation allowing a wide variety of functions to be performed.

- **Remote Interfaces**

RS232 and IEEE-488 interfaces support host computer communications using simple ASCII string commands. A second RS232 interface (COM2) is available for pass through communications to another device.

- **Advanced Measurement Functions**

molboxes support advanced measurement functions such as averaging, flow totalizing, hi/lo and others.

- **Analog MFC Support (molbox1 only)**

An optional board with rear panel connector sets and reads both voltage and current in support of analog mass flow controller (MFC) testing.

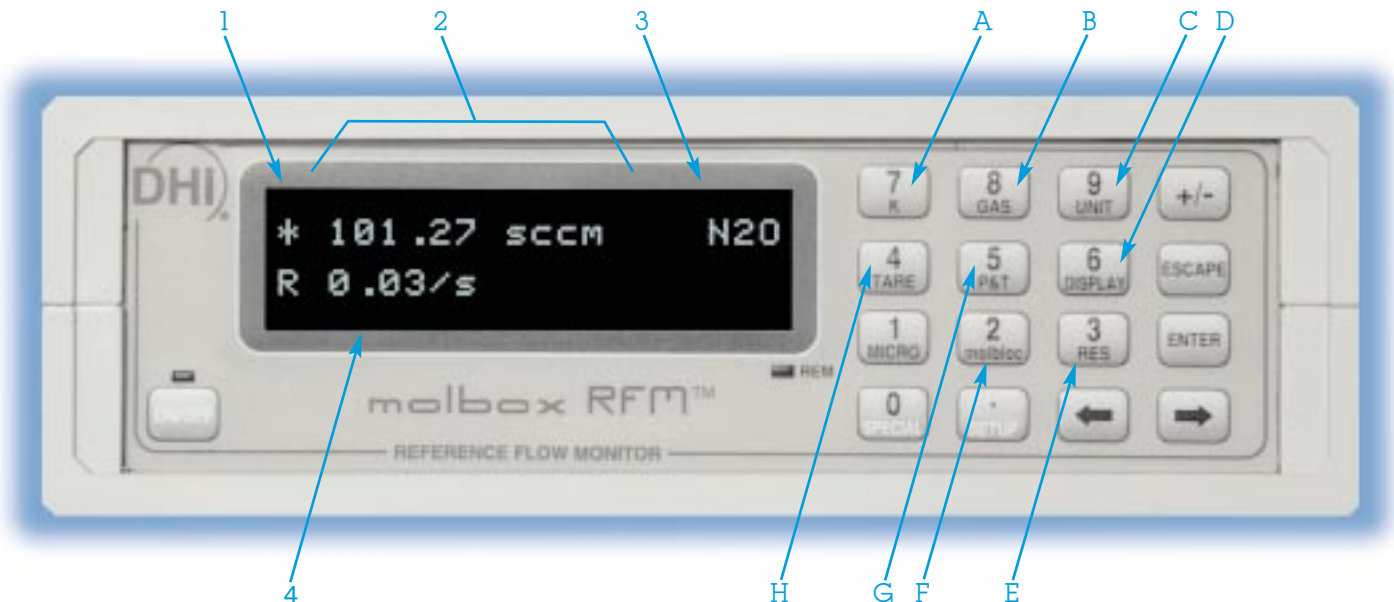

1. Ready/Not Ready indication based on user defined stability test
2. Current rate of flow through the molbloc and unit of measure
3. Gas currently flowing
4. Special functions display line (select, Average, Rate, Hi/Lo, Totalize, Second Flow Unit, Deviation, Freeze or Clean)

- A. **K Function** - Set the device under test (DUT) gas conversion factor (if applicable).
- B. **GAS Function** - Select the gas being flowed (more than 18 gases supported).
- C. **UNIT Function** - Select the mass flow unit of measure with adjustable reference temperature for volumetrically based mass flow units and adjustable pressure and temperature for volume flow units.
- D. **Displays Function** - Select special advanced function displays including Average, Rate, Hi/Lo, Totalize, Second Flow Unit, Deviation, Freeze, Clean.

- E. **Resolution Function** - Adjust the resolution of the measured flow display.
- F. **molbloc Function** - View current molbloc identification, initialize a newly connected molbloc.
- G. **Pressure & Temperature Function** - Display real time molbloc pressure and temperature measurements and the Reynolds number of the current flow.
- H. **Valving Functions** - Access automated pressure tare, leak checking and gas purging functions.



# molbox1™

## molbox1 features include:

- Flow measurement uncertainty of  $\pm 0.2\%$  of reading.
- Very high performance, quartz crystal oscillator based, pressure transducers.
- Two molbloc channels allowing two molblocs to be connected simultaneously and measurements to be switched between them using the A\_B function. Also supports A+B and A/B measurement.
- Integrated analog MFC measurement and control option with switchbox for multiple channels.
- Valve driver option (8 switchable 12V outputs).

## ORDERING INFORMATION

**Description:** molbox1

**Part Number:** FAM0004

## STANDARD DELIVERY

Each molbox1 is delivered complete with:

- Power cord
- Tilt-up front feet
- molbloc to molbox pressure line with quick connectors (4 ea.)
- molbloc to molbox electrical connection cable (2 ea.)
- Rubber feet caps (4 ea.)
- Utility software disc
- User's manual
- Calibration report documenting traceability to the United States National Institute of Standards and Technology (NIST)

## OPTIONS

**Description:** molbox1 Option 009, MFC control option

**Part Number:** 03

**Purpose:** Set and read analog voltage and current MFCs. Optional board is built-in to molbox1 and connector is on rear panel. Delivered with MFC cable and connection kit

**Description:** molbox1 Option 012, drivers option

**Part Number:** 04

**Purpose:** Provide (8) on/off 12 VDC signals to drive external valves or other accessories. Rear panel connector supplied.

## OPTIONAL ACCESSORIES

- **Rack mount kit, molbox1, P/N 401154**  
Standard 19 in. rack mount kit for molbox1. Panel is 5.25 in. (3U) high.
- **MFC Switchbox**  
Supply power to 5 MFCs simultaneously and switch molbox1 MFC control option between five channels. See MFC Switchbox brochure.
- **molstics**  
Gas handling hardware and mounting system for molblocs. See molstic brochure.
- **COMPASS® for molbox**  
PC based calibration software to automate calibrations with molbloc/molbox. See COMPASS for molbox brochure.
- **CalTool for molbloc**  
PC based software for calibration support of molblocs. Allows molbloc calibrations to be adjusted by linear fit to agree with another flow standard with a given gas at a given operating pressure.
- **Training**  
A three day training course for molbloc/molbox operation is conducted regularly at the **DH Instruments, Inc.** Arizona facility. On-site training can also be arranged.



# molbox RFM™



## molbox RFM features include:

- Flow measurement uncertainty of  $\pm 0.5\%$  of reading.
- Microrange option to reduce measurement uncertainty under 10 % of molbloc full scale.
- Micromachined silicon, piezoresistive pressure transducers.
- Very compact presentation.
- Lower cost than molbox1.

## ORDERING INFORMATION

**Description:** molbox RFM

**Part Number:** FAM0005

## STANDARD DELIVERY

Each molbox RFM is delivered complete with:

- Power cord
- Tilt-up front feet
- molbloc to molbox pressure line with quick connectors (2 ea.)
- molbloc to molbox electrical connection cable (1 ea.)
- Utility software disc
- User's manual
- Calibration report documenting traceability to the United States National Institute of Standards and Technology (NIST)

## OPTIONS

**Description:** Microrange option

**Part Number:** 02

**Purpose:** Add 10 kPa (2 psi) differential pressure transducer to improve resolution and lower uncertainty under 10 % of molbloc full scale.

## OPTIONAL ACCESSORIES

- **Rack mount kit, RPM3/molbox RFM, P/N 401465**  
Standard 19 in. rack mount kit for molbox RFM. Panel is 3.5 in. (2U) high.
- **molstics**  
Gas handling hardware and mounting system for molblocs. See molstic brochure.
- **COMPASS® for molbox**  
PC based calibration software to automate calibrations with molbloc/molbox. See COMPASS for molbox brochure.
- **CalTool™ for molbloc**  
For calibration support of molblocs. Allows molbloc calibrations to be adjusted by linear fit to agree with another flow standard with a given gas at a given operating pressure.
- **Training**  
A three day training course for molbloc/molbox operation is conducted regularly at the **DH Instruments, Inc.** Arizona facility. On-site training can also be arranged.

## molbloc RANGES

molblocc sizes are designated by a number relative to their nominal flow impedance. The nominal impedance results in nominal flow ranges when flowing nitrogen gas with 250 kPa absolute (36 psia) upstream pressure and 50 kPa (7.5 psid) differential pressure across the molbloc. In practice, the molbloc flow range may be quite different from the nominal flow range. The difference comes from differences in density and viscosity between gases and from different molbloc operating pressure calibration options. Available molbloc sizes and ranges with various gases by calibration type are listed in the [molbloc Ranges](#) tables (see pp. 15 and 16).

molbloccs are laminar flow elements for use with molbox mass flow terminals. The molbloc flow path is the longitudinal, annular gap between a piston and a close fitting cylindrical bore in the molbloc body. Different molbloc ranges are obtained by varying piston diameters within the same body to vary the size of the annular gap. For high flow ranges (size 1E4 and above), a larger molbloc body with a larger cylindrical bore is used.

The molbloc piston is held in place by the symmetrical elastic deformation of piston holders and, for smaller annular gaps, by interference fit of the piston in the cylinder.

Quick connectors are used to connect the molbloc's upstream and downstream pressure stabilization chambers to the molbox pressure lines. Two platinum resistance thermometers (PRT) are embedded symmetrically in the molbloc body to measure its average temperature. The molbloc is equipped with an EEPROM to store molbloc and PRT calibration coefficients. The EEPROM information, along with the resistance of the PRTs, is read over the molbox 15 pin data cable connection.

All wetted molbloc surfaces are electroplished to a  $0.15 \mu$  Ra to avoid contaminant accumulation in the flow path and molbloccs are assembled under a class 100 clean hood.

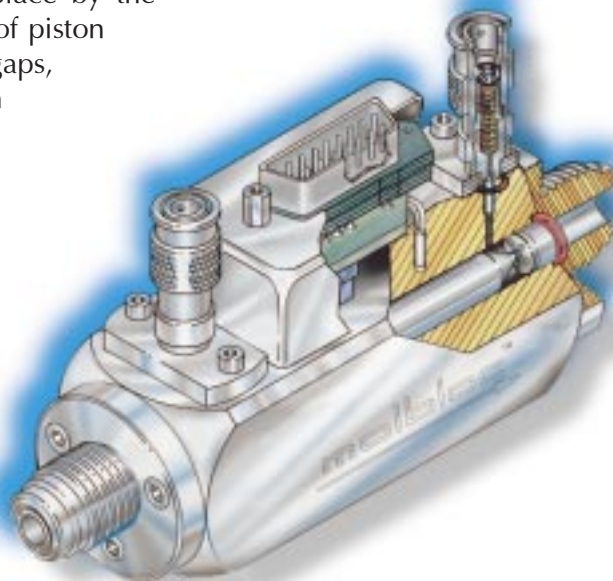

molbloc Cutaway

## molbloc PRESSURE DEPENDENT CALIBRATION TYPES

Different pressure dependent molbloc calibration options are offered to accommodate the operating pressure requirements of different applications. The options are outlined in the [molbloc Pressure Dependent Calibration Types](#) table (see p. 14).



Small molbloc in Case  
(5E3 and Lower)



Large molbloc in Case  
(1E4 and Higher)

See pp. 17 and 18 for complete molbloc/molbox flow measurement specifications.

## ORDERING INFORMATION

### STANDARD DELIVERY

Each molbloc is delivered complete with:

- Storage and shipping case
- Soft, reusable VCR O-rings and mounting instructions
- Full mod, low pressure Nitrogen (N<sub>2</sub>) calibration. A different N<sub>2</sub> calibration and/or calibration with non-N<sub>2</sub> gases must be ordered as separate line item.
- Calibration report documenting traceability to the United States National Institute of Standards and Technology (NIST) and reporting measured calibration data

### molbloc MASS FLOW ELEMENTS

molbloc mass flow elements are ordered by size designation and part number (see table).

DESIGNATOR	DESCRIPTION	PART NO.
1E1 VCR-V-Q	molbloc Mass Flow Element	401182
5E1 VCR-V-Q	molbloc Mass Flow Element	401183
1E2 VCR-V-Q	molbloc Mass Flow Element	401184
2E2 VCR-V-Q	molbloc Mass Flow Element	401187
5E2 VCR-V-Q	molbloc Mass Flow Element	401198
1E3 VCR-V-Q	molbloc Mass Flow Element	400842
5E3 VCR-V-Q	molbloc Mass Flow Element	400483
1E4 VCR-V-Q	molbloc Mass Flow Element	401080
3E4 VCR-V-Q	molbloc Mass Flow Element	401042

### molbloc PRESSURE DEPENDENT CALIBRATION TYPES

To accommodate different requirements, different operating pressure calibration options are available for molbloc. Every molbloc has an N<sub>2</sub> full mod calibration.

- **Full mod, low or high** pressure calibrations are for cases in which the molbloc downstream and upstream pressures will be elevated above atmosphere (usually the case if the device under test is downstream of molbloc). The upstream molbloc pressure may vary within a range. Two ranges are available, high and low pressure.
- **Downstream** calibrations are for cases in which the molbloc downstream pressure is atmospheric pressure (usually the case if the device under test is upstream of the molbloc).
- **Single P, low or high** pressure calibrations are a lower cost alternative to full mod calibrations for non-N<sub>2</sub> gases for cases in which the molbloc downstream pressures will be elevated above atmosphere. Single P calibrations require that the molbloc always be used around the same pressure for that gas.

CALIBRATION TYPE	OPERATING PRESSURE*	NOMINAL DIFFERENTIAL PRESSURE AT MAX FLOW
<b>Full mod, low pressure</b>	250 to 325 kPa absolute (36 to 48 psia) <b>upstream</b> of molbloc	50 kPa (7.5 psi)
<b>Full mod, high pressure</b>	325 to 525 kPa absolute (48 to 76 psia) <b>upstream</b> of molbloc	50 kPa (7.5 psi)
<b>Downstream</b>	Atmospheric pressure <b>downstream</b> of molbloc	80 kPa (12 psi)
<b>Single P, low pressure (non-N<sub>2</sub> gases only)</b>	Any specified single molbloc <b>upstream</b> pressure between 250 and 325 kPa absolute (36 to 48 psia)	50 kPa (7.5 psi)
<b>Single P, high pressure (non-N<sub>2</sub> gases only)</b>	Any specified single molbloc <b>upstream</b> pressure between 325 and 525 kPa absolute (48 to 76 psia)	50 kPa (7.5 psi)

\* Operating pressure values are **absolute**. For approximate **gauge** pressure values, subtract typical atmospheric pressure.

### SPECIAL GAS CALIBRATIONS

Standard molblobs include a Nitrogen (N<sub>2</sub>) full mod, low pressure calibration. A different N<sub>2</sub> calibration and/or calibration with gases other than N<sub>2</sub> must be ordered as separate line items. The **DHI** mass flow calibration facility does not support calibration of all gases for all ranges. Please verify availability before ordering.

DESIGNATION	DESCRIPTION	PART NO.
Special N2 Calibration	Full Mod, Hi P	600204
Special N2 Calibration	Downstream, > 5E1 molbloc	600206
Special N2 Calibration	Downstream, 1E1/5E1 molbloc	600205
Special Gas Calibration	Full Mod, Lo P, 1E1/5E1 molbloc (specify gas)	600202
Special Gas Calibration	Full Mod, Lo P, > 5E1 molbloc (specify gas)	600201
Special Gas Calibration	Full Mod, Hi P, 1E1/5E1 molbloc (specify gas)	600207
Special Gas Calibration	Full Mod, Hi P, > 5E1 molbloc (specify gas)	600208
Special Gas Calibration	Downstream, 1E1/5E1 molbloc (specify gas)	600209
Special Gas Calibration	Downstream, > 5E1 molbloc (specify gas)	600210
Special Gas Calibration	Single P, 1E1/5E1 molbloc (specify gas and single pressure value between 250 and 525 kPa absolute)	600211
Special Gas Calibration	Single P, > 5E1 molbloc (specify gas and single pressure value between 250 and 525 kPa absolute)	600212

## molbloc RANGES WITH LOW PRESSURE CALIBRATIONS

• FULL MOD, LOW PRESSURE

• DOWNSTREAM

• SINGLE P, LOW PRESSURE

			molbloc SIZE AND FULL SCALE FLOW (sccm)								
GASES			SIZE 1E1	SIZE 5E1	SIZE 1E2	SIZE 2E2	SIZE 5E2	SIZE 1E3	SIZE 5E3	SIZE 1E4	SIZE 3E4
INERT	Nitrogen	N <sub>2</sub>	10	50	100	200	500	1 000	5 000	10 000	30 000
	Argon	Ar	10	50	100	200	500	1 000	5 000	10 000	30 000
	Helium	He	10	50	100	200	500	1 000	5 000	10 000	30 000
	Sulfur Hexafluoride	SF <sub>6</sub>	10	50	100	200	500	1 000	<b>2 000</b> <b>500</b>	<b>6 000</b> <b>1 000</b>	<b>6 000</b> <b>4 000</b>
	Xenon	XE	10	40	80	150	400	800	<b>3 500</b> <b>500</b>	8 000	<b>11 000</b> <b>3 000</b>
FLAMMABLE	Butane	C <sub>4</sub> H <sub>10</sub>	20	100	<b>130</b> <b>30</b>	<b>270</b> <b>50</b>	<b>670</b> <b>140</b>	2 300	<b>2 200</b> <b>1 400</b>	<b>7 000</b> <b>3 000</b>	-- --
	Ethane	C <sub>2</sub> H <sub>6</sub>	20	100	200	400	1 000	2 000	<b>6 000</b> <b>1 000</b>	<b>18 000</b> <b>2 000</b>	<b>18 000</b> <b>6 000</b>
	Ethylene	C <sub>2</sub> H <sub>4</sub>	16	80	160	320	800	1 600	<b>7 000</b> <b>1 000</b>	16 000	<b>20 000</b> <b>5 000</b>
	Hydrogen	H <sub>2</sub>	20	100	200	400	1 000	2 000	10 000	20 000	60 000
	Methane	CH <sub>4</sub>	16	80	160	320	800	1 600	8 000	16 000	<b>40 000</b> <b>5 000</b>
	Propane	C <sub>3</sub> H <sub>8</sub>	20	100	200	400	1 000	2 000	<b>3 000</b> <b>1 000</b>	<b>10 000</b> <b>2 000</b>	<b>10 000</b> <b>7 000</b>
FLUORO-CARBONS	Carbon Tetrafluoride	CF <sub>4</sub>	10	50	100	200	500	1 000	<b>4 000</b> <b>600</b>	10 000	<b>12 000</b> <b>3 000</b>
	Hexafluoroethene	C <sub>2</sub> F <sub>6</sub>	10	50	100	200	500	1 000	<b>2 000</b> <b>600</b>	<b>6 000</b> <b>1 200</b>	<b>6 000</b> <b>4 000</b>
	Trifluoromethane	CHF <sub>3</sub>	10	50	100	200	500	1 000	<b>4 000</b> <b>600</b>	10 000	<b>12 000</b> <b>4 000</b>
OTHER	Air	Air	10	50	100	200	500	1 000	5 000	10 000	30 000
	Carbon Dioxide	CO <sub>2</sub>	10	50	100	200	500	1 000	5 000	10 000	<b>20 000</b> <b>4 000</b>
	Carbon Monoxide	CO	10	50	100	200	500	1 000	5 000	10 000	30 000
	Nitrous Oxide	N <sub>2</sub> O	10	50	100	200	500	1 000	5 000	10 000	<b>20 000</b> <b>4 000</b>
	Oxygen	O <sub>2</sub>	10	50	100	200	500	1 000	5 000	10 000	30 000

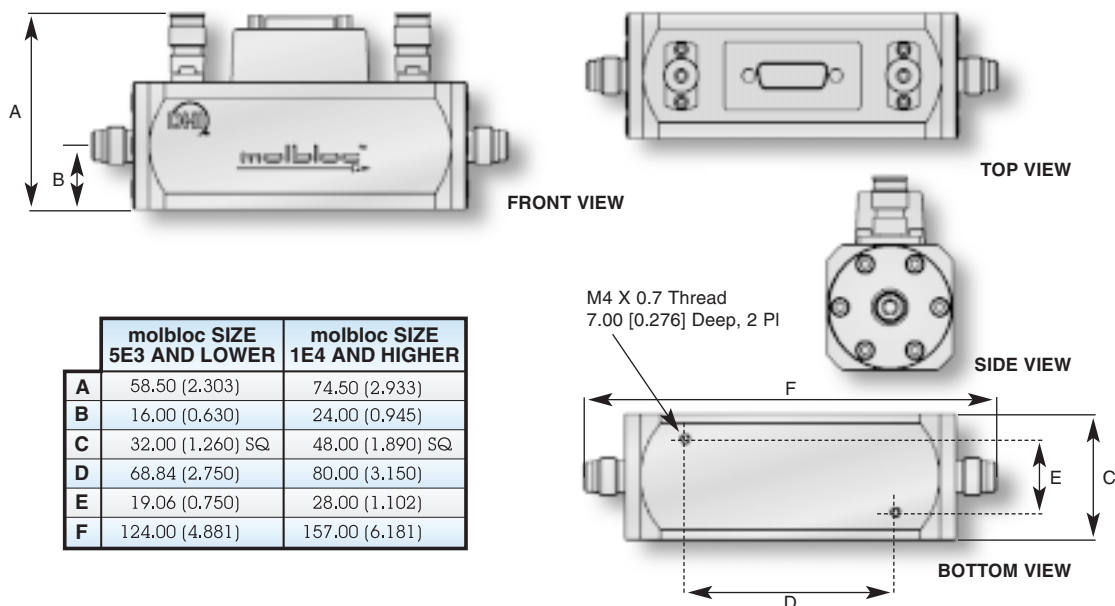

	molbloc SIZE 5E3 AND LOWER	molbloc SIZE 1E4 AND HIGHER
<b>A</b>	58.50 (2.303)	74.50 (2.933)
<b>B</b>	16.00 (0.630)	24.00 (0.945)
<b>C</b>	32.00 (1.260) SQ	48.00 (1.890) SQ
<b>D</b>	68.84 (2.750)	80.00 (3.150)
<b>E</b>	19.06 (0.750)	28.00 (1.102)
<b>F</b>	124.00 (4.881)	157.00 (6.181)

molbloc Dimensions mm [in]



# molbloc RANGES WITH HIGH PRESSURE CALIBRATIONS

- FULL MOD, HIGH PRESSURE
- SINGLE P, HIGH PRESSURE

			molbloc SIZE AND FULL SCALE FLOW (sccm)								
GASES			SIZE 1E1	SIZE 5E1	SIZE 1E2	SIZE 2E2	SIZE 5E2	SIZE 1E3	SIZE 5E3	SIZE 1E4	SIZE 3E4
INERT	Nitrogen	N <sub>2</sub>	20	100	200	400	1 000	2 000	10 000	20 000	40 000 7 500
	Argon	Ar	20	100	200	400	1 000	2 000	10 000	17 000	35 000 6 000
	Helium	He	20	100	200	400	1 000	2 000	10 000	20 000	65 000
	Sulfur Hexafluoride	SF <sub>6</sub>	25	<b>100</b> 15	<b>120</b> 30	<b>250</b> 50	<b>600</b> 150	<b>2 000</b> 300	<b>2 000</b> 1 400	<b>6 200</b> 2 800	-- --
	Xenon	XE	20	100	150	350	650	1 700	<b>3350</b> 950	<b>11 000</b> 1 900	<b>11 000</b> 5 700
FLAMMABLE	Butane	C <sub>4</sub> H <sub>10</sub>	N/A	N/A	N/A	N/A	N/A	N/A	N/A	N/A	N/A
	Ethane	C <sub>2</sub> H <sub>6</sub>	40	200	<b>350</b> 50	<b>700</b> 100	<b>1 800</b> 200	4 000	<b>6 000</b> 2 300	<b>20 000</b> 4 500	<b>20 000</b> 13 800
	Ethylene	C <sub>2</sub> H <sub>4</sub>	40	200	350	700	2 000	4 000	<b>7 000</b> 2 000	<b>22 000</b> 4 000	<b>22 000</b> 12 700
	Hydrogen	H <sub>2</sub>	40	200	400	900	2 000	4 500	22 000	45 000	130 000
	Methane	CH <sub>4</sub>	35	175	350	700	1 700	3 500	<b>13 000</b> 2 000	33 000	<b>42 000</b> 12 000
	Propane	C <sub>3</sub> H <sub>8</sub>	50	<b>200</b> 25	<b>200</b> 50	<b>400</b> 100	<b>1 000</b> 250	<b>3 500</b> 500	<b>3 500</b> 2 600	<b>11 000</b> 5 400	-- --
FLUORO-CARBONS	Carbon Tetrafluoride	CF <sub>4</sub>	20	100	200	400	1 000	2 000	<b>3 700</b> 1 200	<b>12 000</b> 2 400	<b>12 000</b> 7 300
	Hexafluoroethene	C <sub>2</sub> F <sub>6</sub>	25	<b>100</b> 15	<b>120</b> 30	<b>250</b> 50	<b>600</b> 150	<b>2 000</b> 300	<b>1 800</b> 1 500	<b>6 000</b> 3 000	-- --
	Trifluoromethane	CHF <sub>3</sub>	25	125	<b>240</b> 30	<b>450</b> 60	<b>1 200</b> 150	2 500	<b>4 000</b> 1 500	<b>12 000</b> 3 000	<b>12 000</b> 8 800
OTHER	Air	Air	20	100	200	400	1 000	2 000	10 000	20 000	40 000 7 200
	Carbon Dioxide	CO <sub>2</sub>	25	125	250	500	1 250	2 500	<b>6 600</b> 1 400	<b>20 000</b> 2 500	<b>20 000</b> 8 800
	Carbon Monoxide	CO	20	100	200	400	1 000	2 000	10 000	20 000	40 000 7 500
	Oxygen	O <sub>2</sub>	20	100	200	400	1 000	2 000	10 000	20 000	40 000 6 500
	Nitrous Oxide	N <sub>2</sub> O	25	125	250	500	1 250	2 500	<b>11 000</b> 1 500	<b>20 000</b> 3 000	<b>20 000</b> 9 000

## molbloc RANGES TABLES LEGEND

A bold value indicates that the maximum flow is limited by the maximum Reynolds number value of 1 200 which is reached before the normal differential pressure range is reached. In that case, the second value gives the minimum flow for which measurement uncertainty is ± 0.2 % (± 0.5 % with molbox RFM) of reading. With the molbox RFM microrange option, this value is divided by 10. With molbox1 on size 3E4, the ± 0.2 % is ± 0.3 %.

Where there is no value in the table (--), this indicates that the maximum Reynolds number is reached before the differential pressures reaches 5 kPa, therefore calibration with that gas is not useful.

N/A: The operating pressure range is greater than the vapor pressure value for this gas.

### LIST OF SYMBOLS molbloc LAMINAR FLOW ELEMENT (P. 2)

$qm$	= mass flow	[kg/s]	$C_G$	= geometry of molbloc flow path and Reynolds number dependence	[m <sup>3</sup> ]
$P_1$	= upstream absolute pressure	[Pa]	$Re$	= Reynolds number	[-]
$P_2$	= downstream absolute pressure	[Pa]	$M$	= molecular weight of the gas	[g/mol]
$P$	= $\frac{P_1 - P_2}{2}$	[Pa]	$Z_{(P,T)}$	= compressibility factor of the gas under P,T conditions	[-]
$T$	= absolute temperature of gas	[K]	$R$	= universal gas constant	$\left[ \frac{J}{kg \cdot mol \cdot K} \right]$
$\eta_{(P,T)}$	= dynamic gas viscosity under P,T conditions	[Pa•s]	$r$	= radius of the piston	[m]

# molbloc™ / molbox™

## Specifications...

molbox1™

molbox RFM™

### GENERAL

<b>Power Requirements:</b>	85 to 264 VAC, 47 to 440 Hz, 18 VA max consumption
<b>Normal Operating Temperature Range:</b>	15 to 35 °C
<b>Storage Temperature Range:</b>	-20 to 70 °C
<b>Vibration:</b>	Meets MIL-T-28800D
<b>Weight:</b>	6.8 kg (15 lb) max
<b>Dimensions:</b>	32 cm W X 12 cm H X 30 cm D (12.6 in X 4.7 in X 11.8 in) approx.
<b>Microprocessor:</b>	Motorola 68302, 16 MHz
<b>Communication Ports:</b>	RS-232 (COM1), RS-232 (COM2), IEEE-488.2
<b>Reference Pressure Transducers (RPTs):</b>	
Standard	2 x 700 kPa (100 psia) with calibrated range of 550 kPa (80 psia) Oscillating quartz crystal with mechanical bellows
Microrange Option	Not applicable
<b>Pressure Connections (molbox and molbloc):</b>	Quick connectors equivalent to Swagelok® QM Series (-QM2-B200)
<b>Flow Connections (molbloc):</b>	1/4 in. VCR
<b>Pressure Limits:</b>	
Max Working Pressure	550 kPa absolute (80 psia)
Max Pressure W/Out Damage	800 kPa absolute (115 psia)
<b>Ohmic Measurement System:</b>	
Resolution	0.004 Ω
Measurement Uncertainty	± 0.02 % of reading
Accuracy of 100 Ω and 110 Ω Reference Resistors	± 0.01 %
Stability of 100 Ω and 110 Ω Reference Resistors	± 0.005 % per three years
<b>Gases Supported: (11/99)</b>	Nitrogen (N <sub>2</sub> ), Air, Argon (Ar), Butane (C <sub>4</sub> H <sub>10</sub> ), Carbon Monoxide (CO), Helium (He), Oxygen (O <sub>2</sub> ), Carbon Dioxide (CO <sub>2</sub> ), Carbon Tetrafluoride (CF <sub>4</sub> ), Ethane (C <sub>2</sub> H <sub>6</sub> ), Ethylene (C <sub>2</sub> H <sub>4</sub> ), Fluoroform (CHF <sub>3</sub> ), Hexafluoroethane (C <sub>2</sub> F <sub>6</sub> ), Hydrogen (H <sub>2</sub> ), Methane (CH <sub>4</sub> ), Nitrous Oxide (N <sub>2</sub> O), Propane (C <sub>3</sub> H <sub>8</sub> ), Sulfur Hexafluoride (SF <sub>6</sub> ), Xenon (Xe)
<b>Flow Ranges:</b>	0 ~ 10 sccm to 0 ~ 100 slm, see molbloc Ranges Tables, pages 15 and 16
<b>CE Conformance:</b>	Available, must be specified
<b>Valve Driver Option:</b>	(8) 12 V outputs Each output can sink 500 mA at 12 V, max 1 Amp total
<b>MFC Control Option (Analog Output):</b>	
Voltage Range	0 to 6.000 VDC
Voltage Accuracy	± 0.1 % FS
Voltage Resolution	0.1 mVDC
Current Range	4 to 20 mA
Current Accuracy	± 0.1 % FS
Current Resolution	0.4 μA

All specifications same as molbox1 unless specified otherwise.

2.55 kg (5.6 lb) max  
22.5 cm W x 8 cm H x 20 cm D  
(8.9 in. x 3.1 in. x 7.9 in.) approx.

2 x 550 kPa (80 psia) piezoresistive silicon  
12.5 kPa (1.8 psid) piezoresistive silicon

Not available

Not available

**MFC Control Option (Analog Input):**

Voltage Range	0 to 5.000 VDC
Min/Max Measurable Voltage	- 0.25 / 6.000 VDC
Voltage Accuracy	± 0.05 % FS
Voltage Resolution	1 mVDC
Current Range	4 to 20 mA
Current Accuracy	± 0.05 % FS
Current Resolution	0.4 $\mu$ A
Valve Test Point Range	+ 2 to + 15 VDC (in reference to - 15 VDC)
Valve Test Point Accuracy	± 0.25 % FS
Valve Test Point Resolution	2.5 mVDC

**PRESSURE MEASUREMENT**

<b>Type:</b>	Oscillating quartz bellows
<b>Range (FS):</b>	
Standard	0 to 550 kPa absolute (0 to 80 psia)
Microrange Option	Not available
<b>Resolution:</b>	
Standard	0.7 Pa (0.0001 psi)
Microrange Option	Not available
<b>Measurement Uncertainty (One Year):</b>	
Absolute Pressure	± 0.02 % FS
Differential Mode (with Tare)	± (5 Pa (0.0007 psi) + 0.02 % $\Delta$ P)
Microrange Option	Not available

**TEMPERATURE MEASUREMENT (molbloc PRTs with molbox Ohmic Measurement System)**

<b>Type:</b>	Oscillating quartz crystal with mechanical bellows (Digiquartz)
<b>Range (FS):</b>	0 to 40 °C
<b>Resolution:</b>	0.01 °C
<b>Measurement Uncertainty:</b>	± 0.05 °C
<b>On-Board Reference Resistor:</b>	100 and 110 $\Omega$ ± 0.01 %, stability better than 25 ppm/year

**FLOW MEASUREMENT**

<b>Measurement Update Rate:</b>	1 second
<b>Range:</b>	0 to molbloc full scale depending on molbloc designation, gas and molbloc pressure dependent calibration type (see molbloc Ranges Tables pp. 15 and 16)
<b>Resolution:</b>	0.0015 % FS
<b>Linearity:</b>	
Standard	± 0.15 % of reading, ± 0.015 % FS under 10 % FS
Microrange Option	Not available
<b>Repeatability:</b>	
Standard	± 0.05 % of reading, ± 0.05 % FS under 10 % FS
Microrange Option	Not available
<b>Precision<sup>1</sup>:</b>	
Standard	± 0.16 % of reading, ± 0.016 % FS under 10 % FS
Microrange Option	Not available
<b>Predicted Stability<sup>2</sup>(One Year):</b>	
Standard	± 0.1 % of reading, ± 0.01 % FS under 10 % FS
Microrange Option	Not available
<b>Measurement Uncertainty<sup>3</sup> (N<sub>2</sub> and Any molbox Supported Gas for Which the molbloc in Use is Calibrated):</b>	
Standard	± 0.2 % of reading, ± 0.02 % FS under 10 % FS
3E4 molbloc	± 0.3 % of reading, ± 0.03 % FS under 10 % FS
Microrange Option	Not available, all ranges

Not available

Piezoresistive silicon

0 to 12.5 kPa differential (1.8 psid)

5.5 Pa (0.0008 psi)

0.14 Pa (0.00002 psi)

± 0.05% FS

± (20 Pa (0.003 psi) + 0.05 %  $\Delta$ P)± (0.5 Pa (0.0007 psi) + 0.05 %  $\Delta$ P)

Piezoresistive silicon

0.01 % FS

± 0.23 % of reading, ± 0.023 % FS under 10 % FS

± 0.23 % of reading from 1 to 10 % FS,

± 0.023 % FS under 1 % FS

± 0.1 % of reading, ± 0.01 % FS under 10 % FS

± 0.1 % of reading from 1 to 10 % FS,

± 0.01 % FS under 1 % FS

± 0.25 % of reading, ± 0.025 % FS under 10 % FS

± 0.25 % of reading from 1 to 10 % FS,

± 0.025 % FS under 1 % FS

± 0.15 % of reading, ± 0.015 % FS under 10 % FS

± 0.15 % of reading from 1 to 10 % FS,

± 0.015 % FS under 1 % FS

± 0.5 % of reading, ± 0.05 % FS under 10 % FS

± 0.5 % of reading, ± 0.05 % FS under 10 % FS

± 0.5 % of reading from 1 to 10 % FS,

± 0.05 % FS under 1 % FS

<sup>1</sup> Precision: Combined linearity, hysteresis, repeatability.<sup>2</sup> Stability: Maximum change in zero and span over specified time period for typical molbox and molbloc used under typical conditions. As stability can only be predicted, stability for a specific molbox and molbloc should be established from experience.<sup>3</sup> Measurement Uncertainty: Maximum deviation of the molbox flow indication from the true value of the flow through the molbloc including precision, stability and DHI calibration standard accuracy. Measurement uncertainty is sometimes referred to as "accuracy".

# molbloc™/molbox™

## SOME USERS... WORLDWIDE...

### ENVIRONMENTAL QUALITY / MONITORING

Allegheny County Health Dept.  
Indiana Dept. of  
Environmental Management

Dade County Division of  
Environmental Resource  
Management

Florida DEP  
Pennsylvania DEP

TX Natural Resource  
Conservation Commission  
US EPA

### GAS DELIVERY / SPECIALTY GASES

Aera  
Air Liquide  
Brooks Instruments

Millipore  
Praxair  
Teledyne Brown

Pneutronics  
Porter Instruments  
Qualiflow

Redwood Microsystems  
Unit - Kinetics

### MEDICAL / BIO MEDICAL

Abott  
Boston Scientific-Scimed  
Datascope

Datex-Ohmeda  
Edstrom Industries  
Genzyme

Johnson & Johnson  
Merck  
Protein Design Labs

St. Jude Medical  
SmithKline Beecham  
Westaim Biomedical

### NATIONAL MEASUREMENT LABORATORIES

CMI - Czech Republic  
CMS - Taiwan

LNE - France  
NIST - USA

NRC - Canada  
OFMET - Switzerland

PTB - Germany

### NUCLEAR POWER

American Electric Power  
Baltimore Gas & Electric  
Detroit Edison

PECO Energy  
Pennsylvania Power & Light  
Public Service Electric & Gas

Niagara Mohawk  
TU Electric  
Virginia Power

### PETROCHEMICAL R&D

Amoco  
Arco Chemical

Dow Chemical  
Ethyl Petrol Additives

Instituto Mexicano de Petroleos  
Mobil

Rohm & Haas  
Union Carbide

### SEMICONDUCTOR / MICROELECTRONICS / FIBER OPTICS

Advanced Micro Devices  
Alcatel  
Allegro Microsystems  
Analog Devices  
Applied Materials  
Atmel

Cherry Semiconductor  
Cirrent  
Corning  
Eastman Kodak  
Epitaxx  
IBM

Intel  
Intersil  
Lucent  
Mitel  
Motorola  
National Semiconductor

Philips  
SGS Thompson  
Spectran  
3M  
Varian

### OTHER

Aerometrologie  
Babcock and Wilcox  
Bechtel Nevada  
Brigham Young Univ.  
Concoa

Gelman Sciences  
General Motors  
Honeywell Microswitch  
Horiba  
Intertechnique

Laminar Technologies  
Litton Life Support  
Lockheed Martin  
NASA  
North Coast Calibration

Peus  
Pratt & Whitney  
Raytheon  
US Army  
US Airforce

#### Represented Locally By

#### DH Instruments, Inc.

1905 W. 3rd St.  
Tempe, AZ 85281-2490  
USA  
Tel 480/967-1555  
Fax 480/968-3574  
dhi@dhinstruments.com  
www.dhinstruments.com



[www.dhinstruments.com](http://www.dhinstruments.com)

Due to a policy of continuous improvement, all specifications contained in this brochure are subject to change without notice.

Products described herein are protected by US and international patents and patents pending.

molbloc, molbox, molstic and molbox RFM are trademarks of **DH Instruments, Inc.** COMPASS is a registered trademark of **DH Instruments, Inc.**

LabVIEW is a registered trademark of National Instruments Corporation.

Swagelok and VCR are registered trademarks of the Swagelok Company.

Viton is a registered trademark of DuPont Company.

#### In Europe: CalTechnix S.A.

120, av. Charles de Gaulle  
92200 Neuilly sur Seine  
FRANCE  
Tel (1) 46.40.37.70  
Fax (1) 46.40.37.71  
caltechnix@compuserve.com  
www.caltechnix.com