



# ***User Manual*** ***Moisture Analyser***

*AGS series*

*Measuring method description*

## Contents:

1.	General description	3
2.	Completeness	3
3.	Security rules	4
4.	Environment protection	5
5.	Technical data	5
6.	Keys and indicators	6
7.	Preparing moisture analyser to work	7
8.	Interfaces	9
9.	General working rules	9
10.	Description of thermogravimetric analysis	10
10.1	Infrared radiation source	10
10.2	Infrared radiation drying description	10
10.3	Drawing and preparation of a sample	11
10.4	Tools requirements	11
10.5	Single-use pans	11
10.6	Placing a sample	11
10.7	Glass fibre filter	12
10.8	Selection of drying parameters to the sample material	12
10.9	Other practical notes	13
11.	Moisture analyser functioning description	14
11.1	Switching on	14
11.2	Drier operation modes	15
11.3	Calculation methods	16
11.4	Drier operation parameters setting	17
11.4.1	Drying profiles	18
11.5	Moisture analyser settings storing	19
11.5.1	Saving settings	19
11.5.2	Loading saved settings	20
11.6	Initial moisture analysis	21
11.7	Proper moisture analysis	23
11.8	Internal thermometer indications correction	24
12.	Connecting to a computer or a printer	27
13.	Testing and calibration of the balance	29
14.	Moisture analyser as a balance	31
14.1	Units	31
14.2	Auto-zeroing	32
14.3	Calibration	33
15.	Maintenance and repairs of small defects	35
	Declaration of Conformity	37
	Drying parameters for different substances (examples)	38

## **1. General description**

AGS series moisture analyser is destined for fast and precise moisture determination. The moisture analyser is based on two cooperating devices: the balance, used to measure current sample weight, and the dryer, which dries the sample using halogen heaters. Drying parameters may be set according to user preferences. See appendix.

Moisture analysers are mainly destined for use in quality control in food industry, building materials industry, biotechnology, pharmacy, environment protection and others.

Moisture analysers may be also used as laboratory balances for routine weighing (without drying).

## **2. Completeness**

Standard package consists of:

1. Moisture analyser,
2. Pan shield, pan support, pan handle,
3. Single-use pans – 10 pcs,
4. Power supply cord,
5. User manual,
6. Guarantee card.

Options on demand:

6. PT-105 control thermometer with GT-105 sk-8 probe (silicon cable, 160°C) or with GT-105 so-8 probe (cable with steel braid)
7. Distance sleeve 15mm – 1 piece

### 3. Security rules

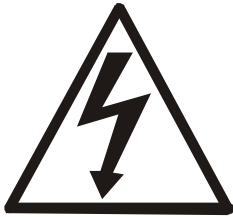

To avoid electrical shock or damage of the moisture analyzer or connected peripheral devices, it is necessary to follow the security rules below.

- To feed the analyser use only mains socket with ground contact.
- Dryer chamber cover heats up to 40°C, but perforated cover at the top may heat up over 60°C. Do not touch the cover top during drying as it may cause severe burns!
- During heating, the halogen heaters warm up to very high temperature. Avoid touching the heaters as it may cause severe burns!
- All repairs and necessary regulations can be made by authorised personnel only.
- Do not use the analyser when its cover is opened.
- Do not use the analyser in explosive conditions.
- Do not use the analyser in high humidity.
- If the device seems not to operate properly, plug it out of the mains and do not use it until checked by authorised service.

## 4. Environment protection

	<p>According to legal regulations it is forbidden to dispose of wasted electronic equipment in waste containers.</p>
<ul style="list-style-type: none"> <li>Please return the wasted device to the point of purchase or to another company specialised in recycling of wasted electronic components.</li> </ul>	

## 5. Technical data

Model	AGS60	AGS120	AGS210	AGS60/T250	AGS120/T250	AGS210/T250
Balance range (Max)	60g	120g	210g	60g	120g	210g
Readout unit (d)	1mg	1mg	1mg	1mg	1mg	1mg
Work temperature	+18 ÷ +33°C					
Humidity readout precision	1% (sample 0,02÷0,5g) 0,1% (sample 0,5÷5g) 0,01% (sample >5g)					
Humidity results repeatability	±0,1% (sample 2g) ±0,04% (sample 5g)					
Drying maximal temperature	160°C			250°C		
Sample time	1 ÷ 180s					
Maximal drying time	10h					
Halogen radiators	2 x 118mm 200W			2 x 118mm 500W		
Chamber heating time up to 100°C	about 3 min.					
Pan dimensions	φ90mm					
Connections	RS232C (to computer or printer), PS2 (to pc keyboard), USB (to computer)					
Dimensions (with legs)	215(235) x 345 x 200mm					
Drying chamber dimensions	φ108 x 20mm					
Supply	~230V 50/60Hz 160VA			~230V 50/60Hz 300VA		
Weight	7kg					
Recommended calibration weight (OIML)	F2 50g	F2 100g	F2 200g	F2 50g	F2 100g	F2 200g

## 6. Keys and indicators

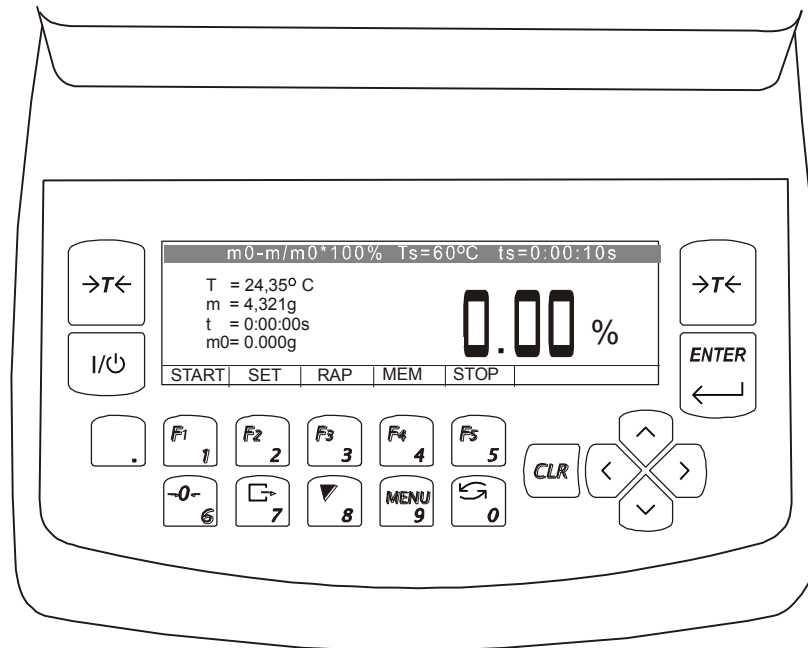

- |                |   |
|----------------|---|
| →T←            | - tare (subtract package weight from weighed mass)                  |
| I/⏻            | - switch- on / switch-off (standby),                                |
| ENTER          | - confirmation / select the option,                                 |
| CLR            | - cancel operation  |
| .              | - decimal point,  |
| 1/F1           | - digit key 1 / START – start measurement (drying),                 |
| 2/F2           | - digit key 2 / SETTINGS – moisture measurement parameters setting, |
| 3/F3           | - digit key 3 / STAT – drying chart, measurement report,            |
| 4/F4           | - digit key 4 / MEM – settings memory,                              |
| 5/F5           | - digit key 5 / STOP – instant drying termination,                  |
| 6/→0←          | - digit key 6 / zeroing (optional)                                  |
| 7/☐→           | - digit key 7 / printout (data transmission),                       |
| 8/▼            | - digit key 8 / autocalibration (unused function),                  |
| 9/MENU         | - digit key 9 / enter the function menu                             |
| 0/↻            | - digit key 0 / mode switching (analyser – balance)                 |
| >              | - enter the option,   |
| <              | - leave the option,   |
| ^              | - navigation / move the cursor up,                                  |
| v              | - navigation / move the cursor down,                                |
| indicator _ _  | - result stabilisation,   |
| bar indicator  | - total load indicator (0-100%),                                    |
| indicator OFF  | - stand-by mode (when switched-off with I/ ⏻, key),                 |
| Max, Min, d, e | - metrologic parameters.  |

## 7. Preparing moisture analyser to work



During heating, the halogen heaters 1 warm up to very high temperature. When drying chamber is opened avoid touching the heaters as it may cause severe burns or damage the heaters!

Dryer chamber cover 3 heats up to 40°C, but perforated cover may heat up over 60°C. Do not touch the top cover during drying as it may cause severe burns!

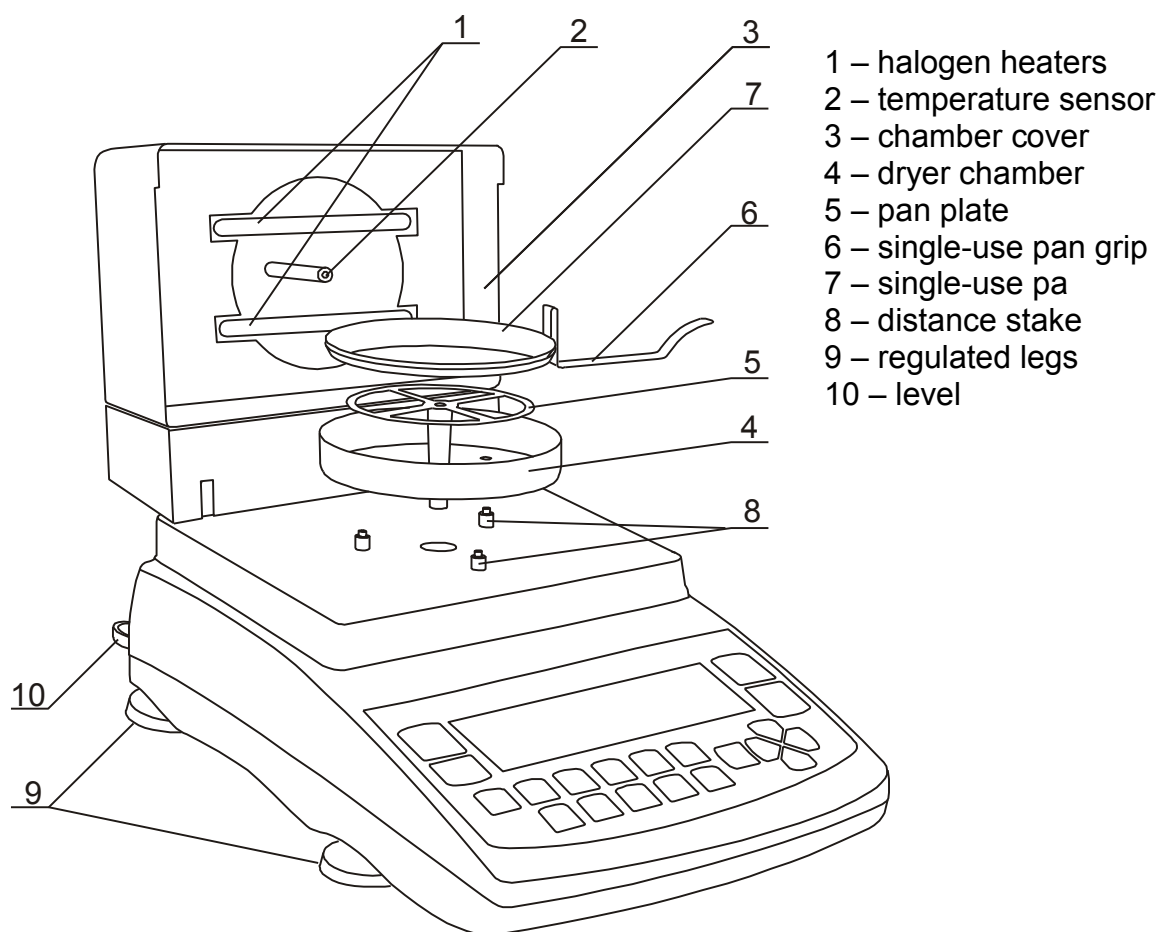

1. Take all contents out of a package: the moisture analyser and packed separately: the tin pan shield, single use pans, the pan handle and the pan support. It is recommended to keep the original moisture analyzer package in order to transport the moisture analyzer safely in future
2. Place the moisture analyzer on a stable ground not affected by mechanical vibrations and airflows.
3. Level the moisture analyzer with rotating legs 9 so that the air bubble in water-level 10 at the back of the moisture analyzer is in the middle and the moisture analyser rests on all four legs.
4. Open the dryer chamber with the handle at the front. Put the pan shield 4 on three distance sleeves 8. Gently insert the pan support 5 into the mechanism hole.
5. Place a single use pan 7 on the pan handle 6 and put the pan on the pan support (the handle should rest on the pan shield so that it does not touch the pan or the pan support).
6. Close the drying chamber cover 3 and plug the device to the mains (230V).

7. After self-tests and result stabilisation zero indication is displayed. The dryer starts initial heating (signalled with an appropriate communicate). After initial heating the moisture analyser is ready to work.



When temperature during initial heating exceeds 105°C or heating time is longer than 1 minute, terminate initial heating with CLR key and check if the temperature sensor 2 works properly and if both halogen heaters light 1 (see chapter 15).

In case any defect occurs contact an authorised service point.

8. The moisture analyzer should not be used to weigh ferromagnetic materials due to accuracy decrease.



## 8. Interfaces

The moisture analyser is equipped with RS232C interface to connect a printer or a computer and with PS2 port to connect an external computer keyboard.

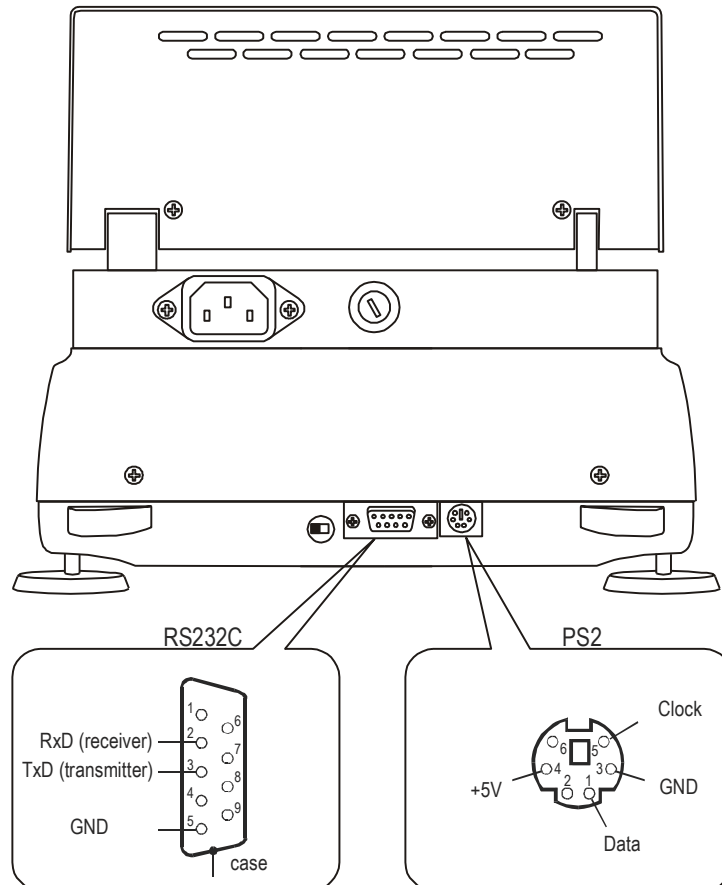

## 9. General working rules



**During transportation remove the pan, the pan support and the pan shield and place it in a separate package.**

1. Distribute a sample all over the pan. A sample surface should not touch temperature sensor placed above the pan.
2. The balance is equipped with the tare equal to its range. To tare the balance press  $\rightarrow T \leftarrow$  key. Writing the tare does not extend measuring range, but only subtracts the tare value from a load placed on the pan. To make weight control easier and to avoid range overdrawn, the balance is equipped with weight indicator (graduated in percentages).
3. Do not overload the moisture analyzer more than 20% of maximum load (*Max*).
4. The mechanism of the balance is a precise device sensitive to mechanical strokes and shocks. Do not press the pan with a hand.

## **10. Description of thermogravimetric analysis**

This section gives some practical details about moisture analysis using infrared radiation for reliable results and easier use of moisture analyser. The description is based on a pre-production experience and customers' suggestions.

Moisture in substances is an essential quality factor of technical and economical importance.

Methods of determining moisture may be grouped in two main categories: absolute and deductive.

Absolute methods are based on simple relations, e.g. weight decline during drying. Thermogravimetric analysis used in AXIS moisture analyser is an example of this method.

Deductive (indirect) methods measure physical quantity related with moisture, e.g. electromagnetic waves absorption, electrical conductance, acoustic wave speed. Some of these methods, unlike thermogravimetric analysis, enable to determine water content.

**Thermogravimetry** - *lat.* thermo – heat, gravi – weight, metry – method

**Thermogravimetric analysis** – a process of determination of a substance mass decline as a result of heat-up. The sample is weighed before and after heating-up, the difference is calculated in relation to initial weight or final weight (dry mass).

### **Moisture in substances**

Thermogravimetric analysis includes all ingredients evaporating from substances during heating-up, which results in weight decrease.

In result of the above, determining of moisture content in substances is not equal water content. Beside water, moisture consists of all other volatile matter: fats, alcohol, aromas, organic dissolvent and other substances resultant as an effect of thermal decomposition.

Thermogravimetric analysis does not distinguish water from other volatile matters.

Infrared radiation drying is more effective than traditional methods (e.g. in an oven) as the radiation deeply penetrates the substance, which shortens drying time.

### **10.1 Infrared radiation source**

AGS series moisture analyser uses 2 halogen heaters (rated power 200W, l=118mm) in serial connection as a radiation source. The heaters emit also visible radiation, which does not affect drying process.

### **10.2 Infrared radiation drying description**

Sample drying is a result of absorption of infrared radiation, which results in sample temperature increase and evaporation of volatile matters.

Infrared radiation penetrates surface layers, the depth depends on penetrability of a sample (different in various substances). Part of radiation is reflected by the sample surface. Penetrated layers absorb the radiation and convert its energy into heat. Emitted heat propagates inside the sample. Effectiveness of the propagation depends on thermal conductivity of the sample. The better the conductivity, the faster drying process and volatile matter evaporation. During drying process sample parameters change, its thermal conductivity decreases so there is a risk of burning the sample. Some parameters may be estimated "by sight", e.g. smooth and light surfaces reflect radiation better. This must be taken into account when setting drying parameters.

### **10.3 Drawing and preparation of a sample**

As sample of given substance must be representative, drawing and preparing a sample is very important process as it affects repeatability of measurements. The most common method of homogenizing a sample is mixing. The other method is to draw few samples from different but specific points in a substance and calculate an average value. Another – to draw few samples from different points in a substance, mix them and draw a sample from the mixed samples.

Sampling method depends on the object of a research. For quality purpose many representative samples are analysed. In production control it is enough to assure sampling repeatability, which enables to study a tendency.

While preparing and drawing, it is important that the sample does not absorb moisture from the environment – it is advised that operation time is as short as possible.

If it is necessary to analyse more than one sample at the same time, the samples should be closed in plastic bags or other isolated containers. Give attention that samples must not lose moisture inside the container (the container should not consist of too much air, the moisture condensed on the sides of the container should be mixed with the sample again).

### **10.4 Tools requirements**

Tools and instruments used in preparation process may affect measurement accuracy, so it is advised not to use tools that transmit heat, as it makes the sample lose moisture before analysis.

Use only special mills and pestles.

In case of liquids with consisting of solid materials use a glass mixer, a spoon or a magnetic mixer.

### **10.5 Single-use pans**

To analyse the moisture, put a sample on a single-use pan and place it in the dryer chamber.

Using non-reusable pan helps to avoid false results by remains of previous samples.

10 single use pans are provided with the moisture analyser. Any quantity may be delivered on demand.

### **10.6 Placing a sample**

A sample should be placed uniformly all over the pan, so that heat propagates equally all over the sample and dries whole sample effectively and quickly without leaving “wet” places.

**Correct**



**Incorrect**

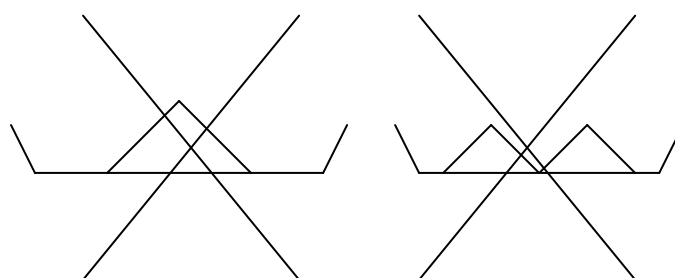

**Attention:**

Due to temperature sensor localisation, max sample height is 10mm.

When substance ply is too thick, surface layers will be heated too much and internal – not enough. This may result in burning the sample or surface incrustation, which will make drying process difficult and measuring result false.

A sample should be placed in uniformed layers 2÷5mm thick, weighing 5÷15g, depending on a substance.

**10.7 Glass fibre filter**

When drying liquids, pastes or substances that may melt or loose liquid during drying, it is advised to use glass fibre filters.

Filters ensure equal liquid distribution or, in case solid materials, avoiding burning a sample.

**10.8 Selection of drying parameters to the sample material**

Selection of proper temperature and drying time is essential to achieve precise humidity measurement. Drying parameters are selected properly if repeatability is on satisfactory level, usually between 0,1÷1%.

Parameters choice should be made in 3 steps:

**Step 1:** Drying temperature is related to the physico-chemical properties of the sample. It is determined by the number of tests carried out in several successive temperatures, e.g., at intervals of 10 ° C. Proper temperature is the highest value for which the sample for a few minutes does not change color and smell. Changing the color or odor indicates the start of the oxidation of the sample, which changes the properties of the sample, which usually affects the measurement accuracy.

**Step 2:** Weight of sample used should be large enough to use the entire surface of the pan, however, the thinner the layer of sample the better the drying process proceeds. The top and bottom layers of the material should be dried similarly at the same time. If the material is covered with shell and some moisture is trapped in the material, user should disintegrate the material or reduce the drying temperature. For liquid materials is preferable to use filter which accelerates the drying.

**Step 3:** Select drying time to chosen mass of sample. To do this, set the moisture analyzer's drying time as long as possible and observe the drying process. Minimum drying time is the one at which the sample doesn't change its weight by more than allowed by the examiner measurement error. Proper drying time is designated minimum drying time with reserve. The percentage value of the reserve must exceed the mass of the sample dispersion - the drying sample time is proportional to the mass of the sample.

After a few measurements with the designated drying parameters and making sure that the reproducibility of the results is satisfactory user can proceed to optimize the measurement time by selecting favorable *Drying profile* and using *Short* measurement mode. Of course you should check that the reproducibility of the results was not seriously affected.

Sample values for the most common materials are given in the Appendix, however, be regarded only as preliminary data and it is recommended to carry out the procedure for parameters selection for the test material.

### **10.9 Other practical notes**

It is preferable to work with the same mass of the sample at each measurement to measure the size of the sample in a reproducible way. It is best to use the same instruments for the application of the sample.

Put a sample on the pan as quickly as possible to avoid losing moisture.

Temperature inside the chamber is much higher than outside, so the sample may evaporate partly before measurement begins, which will result in a false result.

When analysing the same substance quantity in successive measurements, use the same tools to put a sample to be sure that samples are each time of the same size.

Before putting a sample, tare a single-use pan and take it out of the chamber. Right after putting a sample on the pan, place it inside the analyser chamber, close the chamber and press START.

Be sure that no dirt sticks under the pan, as it may increase sample weight and result in false values.

## 11. Moisture analyser functioning description

### 11.1 Switching on

After switching-on the moisture analyser proceeds with self-tests.

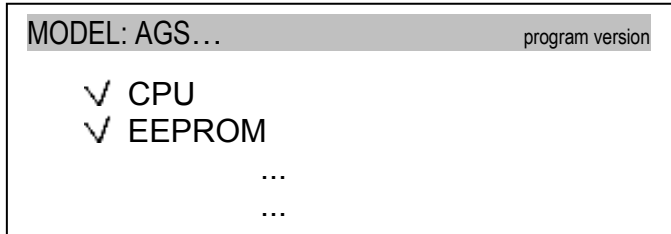

After completing self-tests, the analyser is tared and the dryer begins initial heating necessary to create thermal conditions suitable for measurements.

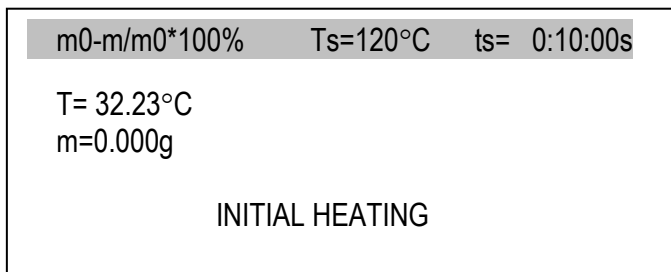

Initial heating should warm the drying chamber up to 105°C within 3 minutes. When temperature during initial heating exceeds 105°C or heating time is longer than 3 minutes, terminate initial heating with CLR key and check if the analyser is not damaged (see chapter 15).

After initial heating is completed (or terminated), the device displays the following information:

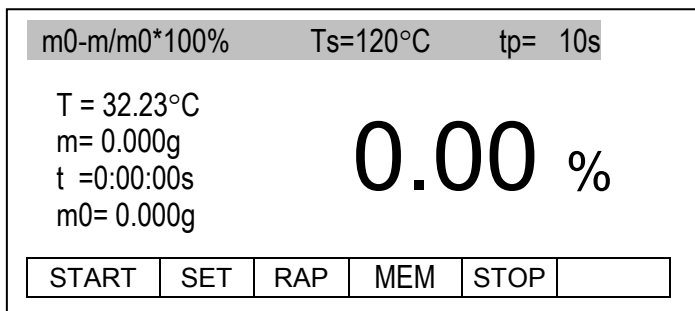

Legend:

m0-m/m0\*100% - formula used to calculate the moisture

Ts – defined drying temperature

ts – defined drying time

T – current temperature in the drying chamber

m – current weight,

t – current drying time

m0 – initial weight

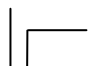
 - indicator of drying profile

## 11.2 Drier operation modes

During the balance – drier operation sampling of the mass on the pan takes place. Sampling time is set by the user, according to drying process speed. As a result of sampling the current humidity value is calculated and displayed. Measurement is finished depending on selected Drying mode:

1. In *Time mode* total humidity measurement time (Drying time) is defined by the user,
2. In *Short mode* humidity measurement is finished, when drying is stopped and differences of a few successive mass samples are smaller than threshold value (2 mg). Amount of successive samples taken into consideration is defined as *Samples quantity*. Measurement is finished when Drying time is exceeded at the latest.

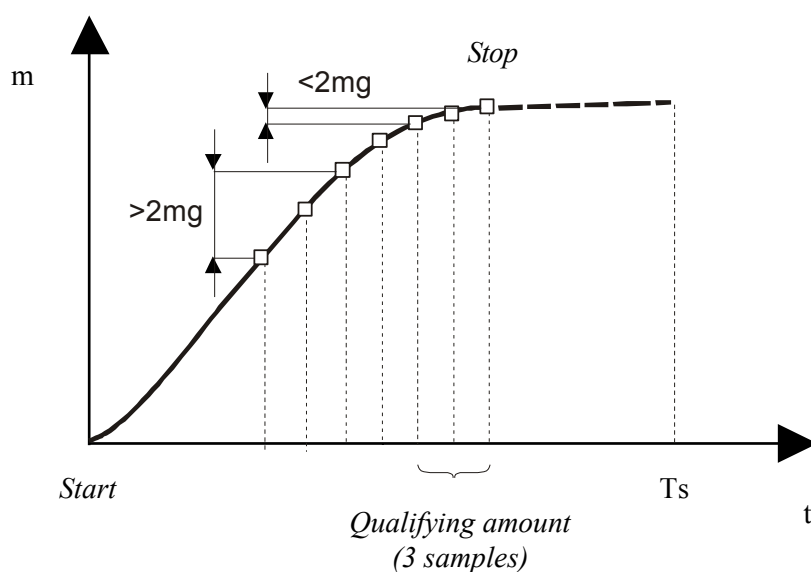

Drying chart in *Short mode* for *Samples quantity* = 3.

### 11.3 Calculation methods

Humidity may be calculated upon the basis of various mathematic formulas, defined in balance – drier as *Calculation method*:

1. Relative humidity, defined in relation to initial mass

$$w [\%] = m_0 - m / m_0 * 100\% ,$$

where  $m_0$  – initial mass,  $m$ - current mass

2. Relative humidity, defined in relation to current mass

$$w [\%] = m_0 - m / m * 100\% ,$$

3. Percent current mass content in sample

$$w [\%] = m / m_0 * 100\% .$$

*Drying temperature* is maximum temperature, measured by sensor, located in the dried material vicinity. Note that the dried material temperature may be higher than its surrounding temperature.



### 11.4 Drier operation parameters setting

m0-m/m0*100%		Ts=120°C	ts= 0:10:00s		
T = 32.23°C					
m = 0.000g					
t = 0:00:00s					
m0= 0.000g					
<b>0.00 %</b>					
START	SET	RAP	MEM	STOP	

F1	F2	F3	F4	F5
----	----	----	----	----

SETTINGS		
1. Drying temp.	:	60°C
2. Mode	:	Time mode
3. Calculation	:	m0-m/m0*100%
4. Samples quantity	:	2
5. Sampling interval	:	10s
6. Drying time	:	0:00:10s
7. Drying profiles	:	
8. Settings storing	:	1

ENTER
-------

SETTINGS		
1. Drying temp.	:	60°C
2. Mode	:	Time mode
3. Calculation	:	m0-m/m0*100%
4. Samples quantity	:	2
5. Sampling interval	:	10s
6. Drying time	:	0:00:10s
7. Drying profiles	:	
8. Settings storing	:	1
9. Temp. correction	:	

<	>	ENTER
---	---	-------



SETTINGS		
1. Drying temp.	:	60°C
2. Mode	:	Time mode
3. Calculation	:	m0-m/m0*100%
4. Samples quantity	:	2
5. Sampling interval	:	10s
6. Drying time	:	0:00:10s
7. Drying profiles	:	
8. Settings storing	:	1
9. Temp. correction	:	
10. Exit	:	

Select *Settings* option by pressing **F2** key.

With the navigation keys **^** and **v** successive menu positions are selected, e.g. *Mode*.

To go to options selection press **ENTER**.

Appropriate option, e.g. *Time mode*, is selected with the navigation keys **<** and **>**. Selected option is accepted after pressing **ENTER**.

Set the following positions:

- *Operation Mode* – *Time mode* or *short mode*,
  - *Calculation method* – humidity calculation formula,
  - *Drying temperature* – temperature in drying chamber),...
  - *Samples quantity* (2, 3, 4 or 5) – amount deciding of drying end (in case of *Short mode* only)
  - *Sampling interval* – interval between successive mass measurements (1÷180s.),
  - *Drying time* (1s ÷10h) (in *Short mode* it will be the maximum allowable time for drying process)
  - *Drying profile* – (standard, slow, step or quick type)
  - *Settings storing*– number of memory location (1÷20), where the settings will be stored.
- To finish settings, select *Exit* and press **ENTER**.

**Note:** All defined parameters are stored in the memory until the next changed (also after unplugging the device from the mains).

### 11.4.1 Drying profiles

DRYING PROFILES		
1. Drying temp.	:	120°C
2. Mode	:	Short mode
3. Calculation	:	m0-m/m0*100%
4. Samples quantity	:	2 samples
5. Sampling interval	:	10s
6. Drying time	:	0:10:00s
7. Drying profiles	:	standard
8. Settings storing	:	1
9. Temp. correction	:	

ENTER

*Drying profile* will be used to optimization of drying process by accommodation a process to physical properties of sample material.

*Step* or *slow* profile can be used to oxidizing or surfaces thicken materials. *Quick* profile can be used to immune materials.

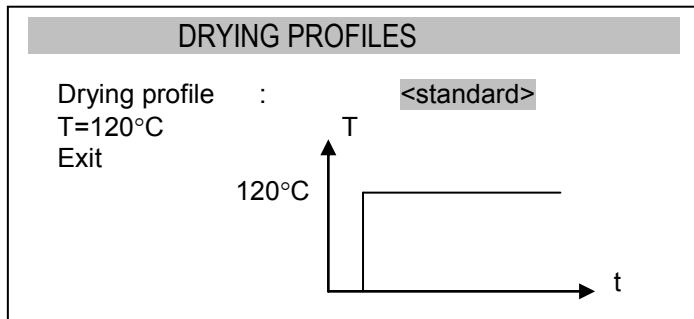

Profile chooses and his parameters should be the result of experience with the test material.

Selected a drying profile by ENTER key, choose a adequate profile (*standard*, *slow*, *step* or *quick*) and set a temperature (T) and time (t) value.

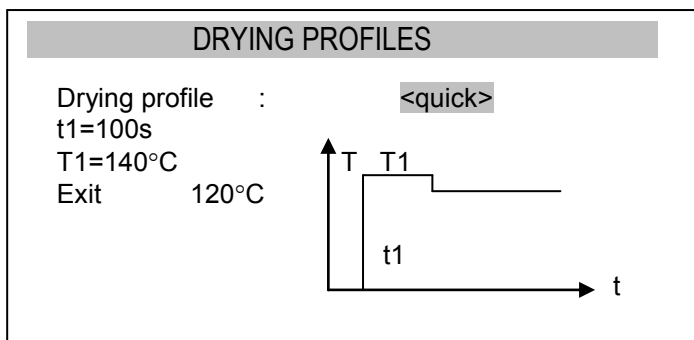
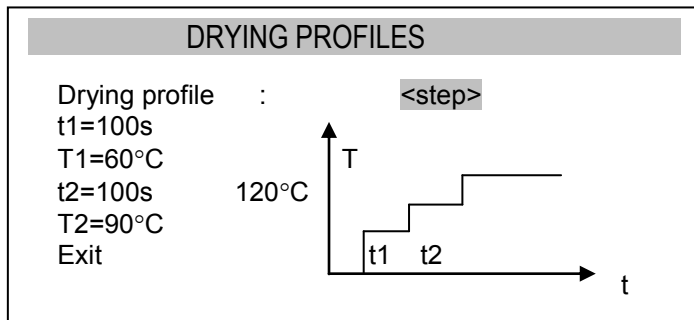
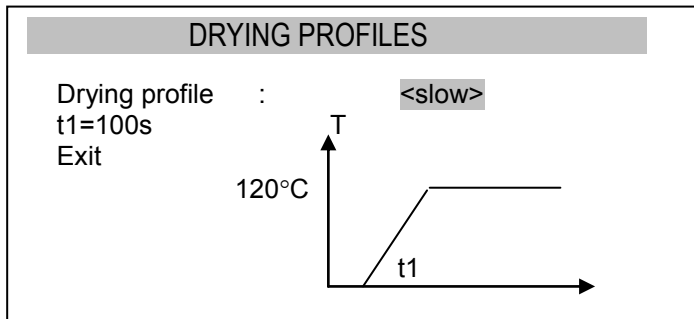

**Caution:**

The ending temperature can be setting on *Standard profile* or *Setting (Main menu)* only

### 11.5 Moisture analyser settings storing

The moisture analyser enables to save 10 different drying settings. Saved settings are kept in the memory even after unplugging moisture analyzer from the mains.

#### 11.5.1 Saving settings

To save drying settings follow the instructions below:

ms-ma/ms*100%		T=120°C		ts= 0:10:00s	
T = 32.23°C					
m = 0.000g					
t = 0:00:00s					
m0= 0.000g					
START	SET	RAP	MEM	STOP	

Press *F2* key to choose *SET* option.

SETTINGS		
1. Drying temp.	:	60°C
2. Mode	:	Time mode
3. Calculation	:	m0-m/m0*100%
4. Samples quantity	:	OFF
5. Sampling interval	:	10s
6. Drying time	:	0:00:10s
7. Settings storing	:	< 1 >
Exit		

Set necessary drying settings (see chapter 11.4).  
Select *Settings storing* option using  $\wedge$  and  $\vee$  and press *ENTER* to accept.

<	>	ENTER
---	---	-------

SETTINGS		
1. Mode	:	Time mode
2. Calculation	:	m0-m/m0*100%
3. Drying temp.	:	60°C
4. Samples quantity	:	OFF
5. Sampling interval	:	10s
6. Drying time	:	0:00:10s
7. Drying profiles	:	
8. Settings storing	:	< 2 >
Exit		

Choose a reference number for specific setting using  $<$  and  $>$  keys and press *ENTER* to accept. Than chose *Exit* and press *ENTER*.

<	>	ENTER
---	---	-------

SETTINGS	
Save settings?	
NO	
YES	

To save settings choose *YES* and press *ENTER* to accept.

ENTER
-------

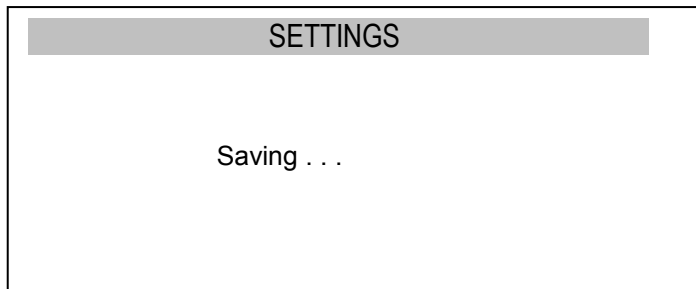

The analyser displays a short communicate *Saving....* After the parameters are saved the analyser is ready to work with new drying parameters.

### 11.5.2 Loading saved settings

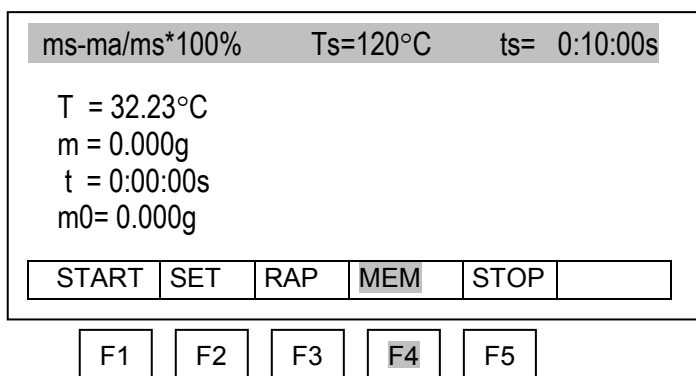

To load saved settings, stored in the memory, choose *MEM* option using *F4* key.

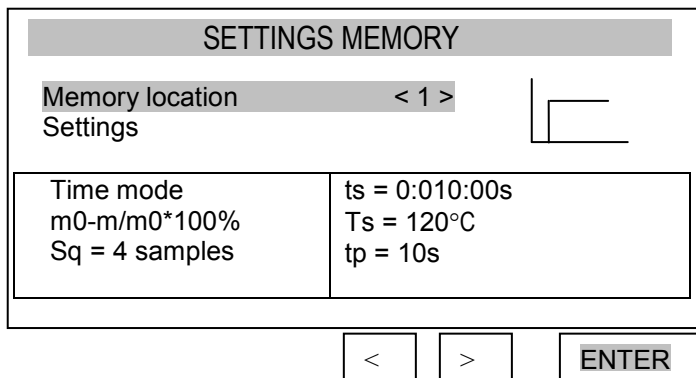

Select a number of desired settings using navigation keys < and >. Press *ENTER* to accept.

### 11.6 Initial moisture analysis

To determine optimal drying parameters for unknown sample, it is recommended to perform initial measurement with activated drying chart displaying. To do this, set the following drying parameters (see Drying parameters setting):

- Operation Mode: Time mode
- Calculation method:  $m - m_0 / m_0 * 100\%$
- Drying temperature:  
 organic substances: 80 - 120 °C  
 inorganic substances: 140 - 160 °C
- Samples quantity: do not set
- Sampling interval: 1 second
- Drying time: set time, after which the sample will be definitely dried

To activate displaying of drying chart, which will be visible on the display instead of humidity indication, perform the following actions:

$m - m_0 / m_0 * 100\%$		Ts=120°C	ts= 0:10:00s
T = 32.23°C	<b>0.00 %</b>		
m= 0.000g			
t =0:00:00s			
m0= 0.000g			
START	SET	<b>RAP</b>	MEM
		STOP	

Choose *RAP* option with *F3* key, select *Drying chart* and press *ENTER*.

F1	F2	<b>F3</b>	F4	F5
----	----	-----------	----	----

DRYING OPTIONS
<ol style="list-style-type: none"> <li>1. Average</li> <li>2. <b>Drying chart</b></li> <li>3. Transmission</li> <li>4. Exit</li> </ol>

Choose *Drying chart* using  $\wedge$  and  $\vee$  keys and press *ENTER*.

<b>ENTER</b>
--------------

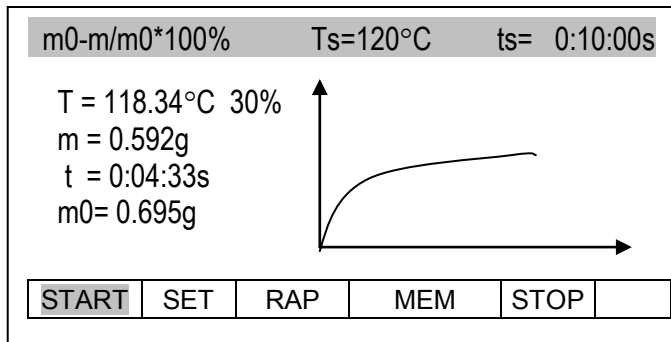

When drying chart is visible, place a sample on the pan and choose **START** option (**F1** key). Drying parameters and drying process chart are presented on the display.

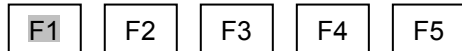

Observing drying process chart it is possible to evaluate its course and define time required for complete drying. The chart shows 160 time samples on the X axis (for longer times chart is scaled to 360 samples, 720, etc.) and humidity value according to selected formula on the Y axis (chart is automatically scaled to 10%, 30%, 50%, etc.). Selecting 1 s of sampling time allows for more precise chart.

Achieved chart allows for initial settings selection for main measurement. *Drying temperature* should be selected according to dries material type, so the drying is performed quickly and sample does not change colour. Material drying moment is visible on the chart as drying characteristic bending. As *Drying time* for main humidity measurement select time from the beginning to chart “flattening”. As the time axis is not described on the chart, use “evaluation with high margin”. Too short drying time does not allow to achieve precise humidity measurement results.

In case of *Short mode*, in main measurement select *Sampling time*, which allows to include approx. 10 samples in time of characteristic bending. If drying is finished too quickly, increase *Samples quantity* or *Sampling time*.

### Notes:

1. Before main measurement remember about deactivating of chart displaying.
2. To improve operation it is possible to use *Promas* software (available on demand), which generates precise drying chart.

### 11.7 Proper moisture analysis

Before measurement carefully prepare the sample (as described in chapter Description of Thermogravimetric Analysis) and set correct drying parameters (see chapter Working Parameters Setting and use the graph created e.g. in 11.6 chapter).

m0-m/m0*100%		Ts=120°C	ts= 0:10:00s		
T = 32.23°C	<h1>0.00 %</h1>				
m= 0.000g					
t =0:00:00s					
m0= 0.000g					
START	SET	RAP	MEM	STOP	SAMPLE

→T←

Place an empty single-use pan and tare the balance with →T← key. Open the drying chamber and using the pan handle place the single-use pan with the sample on the pan support. Close the chamber.

m0-m/m0*100%		Ts=120°C	ts= 0:10:00s		
T = 32.23°C	<h1>0.00 %</h1>				
m= 2.033g					
t =0:00:00s					
m0= 2.033g					
START	SET	RAP	MEM	STOP	SAMPLE

F1
F2
F3
F4
F5

Start the measurement choosing **START** option (F1 key). Drying in progress is signalled with alternating **SAMPLE /DRYING** communicate.

Wait until **END** communicate appears. Now read the result.

m0-m/m0*100%		Ts=120°C	ts= 0:10:00s		
T = 32.23°C	<h1>1.00 %</h1>				
m= 2.013g					
t =0:00:50s					
m0= 2.033g					
START	SET	RAP	MEM	STOP	END

**Attention:** No **STB** communicate and **m0** sign in negative, marks acceptance of unstable initial mass value **m0**, caused by pressing the pan to chamber wall or by too fast sample drying, which can cause to measurement failures.

During the measurement the following information is displayed:

**m0-m/m0\*100%** - mathematic formula used for calculations

**T s** – defined drying temperature

**ts** - defined drying time

**T** – current drying temperature

**m** – current weight

**t** – current drying time

**m0** – initial weight

### 11.8 Internal thermometer indications correction

m0-m/m0*100%		Ts=120°C		ts= 0:10:00s	
T = 32.23°C		<h1>0.00 %</h1>			
m= 0.000g					
t =0:00:00s					
m0= 0.000g					
START	UST	RAP	PAM	STOP	

F1	F2	F3	F4	F5
----	----	----	----	----

SETTINGS		
1. Mode	:	Time mode
2. Calculation	:	m0-m/m0*100%
3. Drying temp.	:	60°C
4. Samples quantity	:	OFF
5. Sampling interval	:	10s
6. Drying time	:	0:00:10s
7. Drying profiles	:	Slow
8. Settings storing	:	1
9. Temp. correction	:	OFF
Exit		

CORRECTION TEMPERATURE		
1. Device temp.	T1 =	
2. Contr. temp.	T1=	
3. Device temp.	T2 =	
4. Contr. temp.	T2=	
5. Status	<ON>	
6. Exit		

If necessary 2 point indication correction of internal moisture analyzer thermometer based on measurement made by external control thermometer is available (inscribe temperature values  $T1$  and  $T2$  and their equivalent values measured by external thermometer and then set *Status* to ON).

Choose option *Settings* by pressing

*F2* key.

By using navigation keys  $\wedge$  and  $\vee$  choose *Temp. correction*.

In order to inscribe temperatures press *ENTER* key.

In order to end setting option choose *Exit* and press *ENTER*.

Maximal correction depth: 20°C.

Conditions:

-  $T2 > T1$

-  $T1 \text{ i } T2 \leq 160^\circ\text{C}$  (for AGS../T250:  $T1 \text{ i } T2 \leq 250^\circ\text{C}$ )

-  $T2-T1 \geq 25^\circ\text{C}$

If the conditions aren't fulfilled, during status change to ON, a error communicate will appear.

Suggested thermometer type: PT-105 with probe GT-105



The way of entering control thermometer probe to moisture analyzer drying chamber:

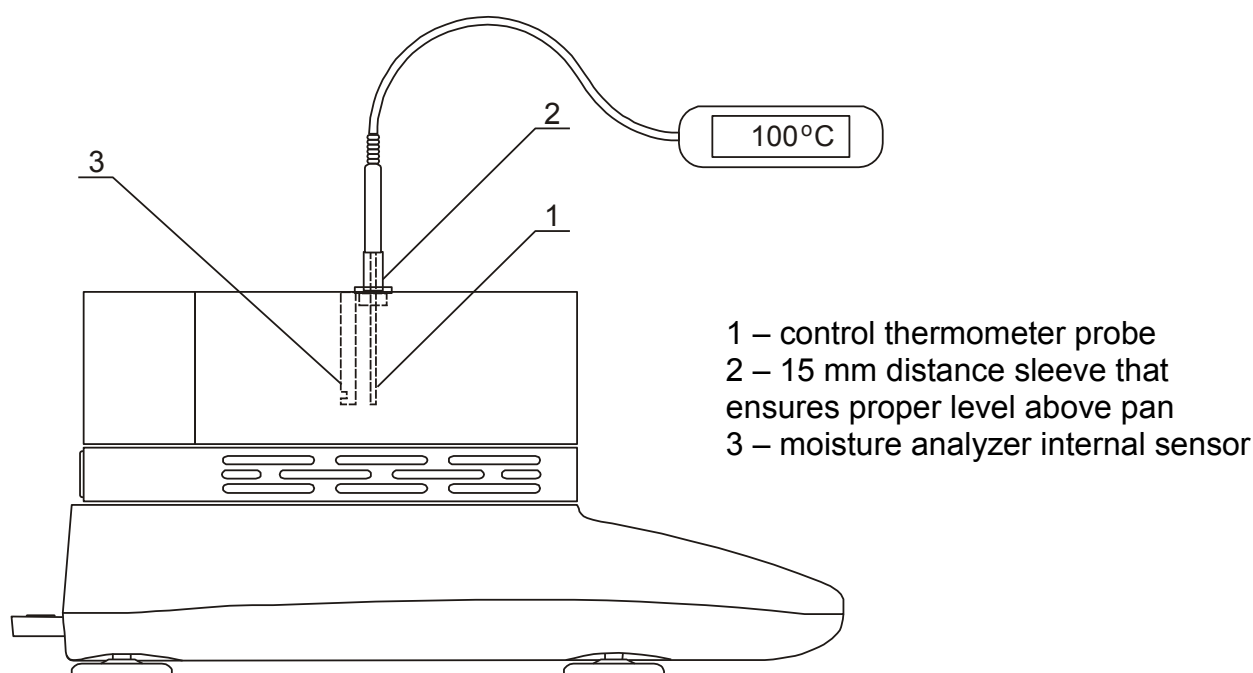

Before executing temperature correction (inscribing T1 and T2 temperature) drying cycle must be made with inscribed T1 temperature and drying time 15 minutes. Single-use pan (a new one) should be put on the pan . When drying process is almost done write down moisture analyzer temperature indication ( T value on the left side of moisture analyzer display) and control thermometer indications. Both indications are needed for correction:

CORRECTION TEMPERATURE	
1. Device temp.	T1 =
2. Contr. temp.	T1=
3. Device temp.	T2 =
4. Contr. temp.	T2=
5. Status	<ON>
6. Exit	

Subsequently make drying cycle for T2 temperature (drying time as above 15 minutes) and write down indications again. This way both T2 indications are inscribed:

CORRECTION TEMPERATURE	
1. Device temp.	T1 =
2. Contr. temp.	T1=
3. Device temp.	T2 =
4. Contr. temp.	T2=
5. Status	<ON>
6. Exit	

Moisture analyzer internal thermometer correction is made with internal thermometer and control thermometer on the same level (11mm) above the sample.

**Attention:** The temperature indicated by thermometer situated on some level above the sample can differ from real temperature of the sample. In this case if there is a need for temperature indication correction simply lower the level of control thermometer by removing distance sleeve.

During correction control thermometer can't touch the sample.

Correct:

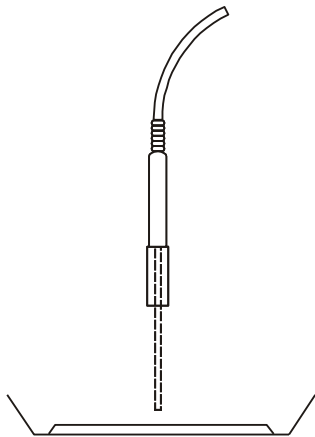

Uncorrect:

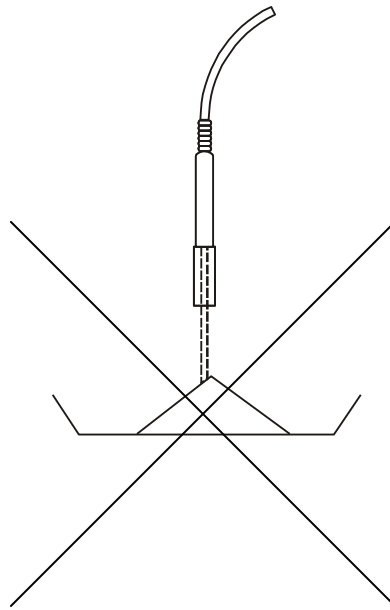

### 11.9 Connecting to a computer or a printer

When drying process is finished measurement result can be send to printer or a computer via RS232C interface.

Measuring data can be also completed with text information. To enter text descriptions it is necessary to connect a computer keyboard to PS2 port at the back of the moisture analyser.

m0-m/m0*100%      Ts=120°C      ts= 0:10:00s					
T = 32.23°C					
m= 2.033g					
t =0:00:00s					
m0= 2.033g					
<b>0.00 %</b>					
START	SET	RAP	MEM	STOP	SAMPLE
F1	F2	F3	F4	F5	

Choose *RAP* option (F3 key).

DRYING REPORT		
1. Drying chart	:	ON
2. Product name	:	
3. Executive	:	
4. Notes	:	
5. Transmission	:	OFF
Exit		

Using navigation keys and *ENTER* key choose *Drying chart* and disable or enable printing and displaying the chart.

DRYING REPORT		
1. Drying chart	:	ON
2. Product name	:	
3. Executive	:	
4. Notes	:	
5. Transmission	:	OFF
Exit		

Set necessary options:

- *Product name*,
- *Executive*,
- *Notes*.

and with the connected computer keyboard enter text information (max 19 signs) for printed report. Use PS-2 socket. Set of available signs is presented on next page.

Activation of *Transmission* option will activate sending of all sampling results through the RS232C port. The may be printed by the printer or stored in the computer, e.g. by the *Promas* software.

A set of characters available using the keyboard while you use *Product name*, *Executive* or *Notes*:

1 . , ' ? ! " - ( ) @ / : \_ ; + & % \* = < > \$ [ ] { } \ ~ ^ ' # |  
 2 A B C a b c  
 3 D E F d e f  
 4 G H I g h i  
 5 J K L j k l  
 6 M N O m n o  
 7 P Q R S p q r s  
 8 T U V t u v  
 9 W X Y Z w x y z  
 0 space

Erasing the mark and move the cursor to the left: the navigation key <.

To print the drying report press  key.

Drying started:	
-----	
Date:	2004-06-10
Time.:	12:34:33
Drying parameters	
-----	
Product	
Drying temperature :	130C
Mode :	Short mode
Calculation :	m0-m/m0*100%
Finished :	time over
Initial weight :	0.000 g
Final weight :	0.000 g
Drying time :	0:00:00s.
Sampling interval:	10s
Moisture :	0.00%
NOTE:	
The analysis proceeded by:	
Signature .....	

It is possible to set necessary serial port parameter values (8bit, 1stop, no parity, 4800bps). To use *RS232C Settings* option press  key (weighing mode) and press *MENU* key.

Besides RS232C interface moisture analyser can be equipped with USB or Wi-Fi.

## 12. Moisture analyzer menu diagram

All operations described in chapter 11 can also be executed using moisture analyzer menu. In order to do that use *MENU* key and using navigation keys and *ENTER* key choose proper options.

Menu diagram:

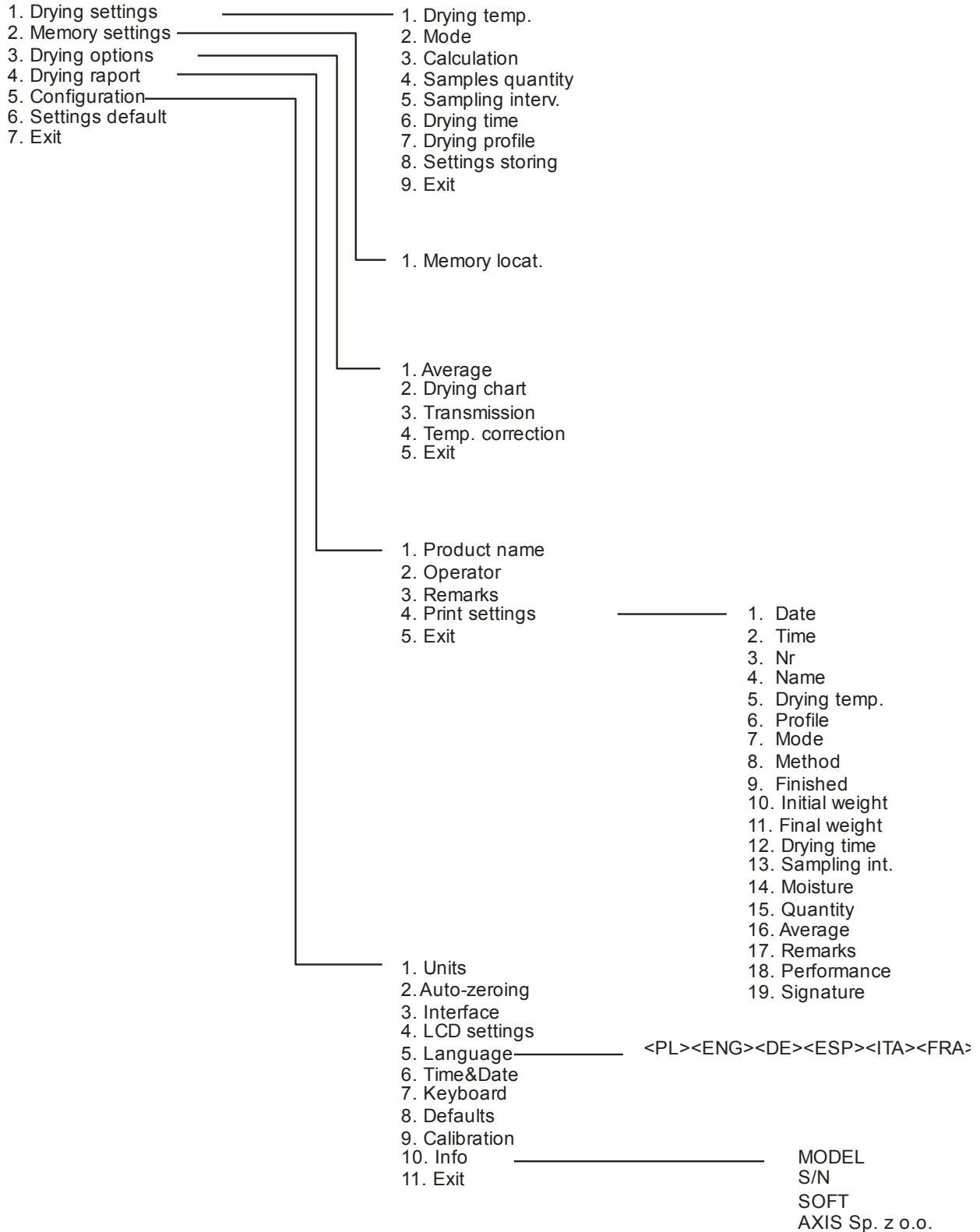

### **13. Testing and calibration of the balance**

To check the weighing function of balance – drier, switch it to simple weighing mode (↶ key) and check it by putting precisely weighed object, e.g. calibration weight F2 (OIML), equal to device measurement range. In case of any inaccuracies perform the balance calibration. The balance calibration is performed by activating a calibration function, available in special functions menu, and putting the calibration weight on the pan according to indications on the display (see *Sensitivity calibration function*).

Control of humidity measurement precision requires use of standard substance – disodium tartrate (di-Sodium tartrate dihydrate  $C_4H_4Na_2O_6 \cdot H_2O$ ). For the control use 5 g sample, setting: short mode, calculations method:  $m/m_0 \cdot 100\%$ , temperature  $150^\circ C$ , sampling time 10 s, samples amount 4 and drying time 00:15:00s.

The result should be contained in range 15.61 – 15.71%.

## 14. Moisture analyser as a balance

The moisture analyser may be also used as a normal balance. To switch between analyser / weighing mode press ↵ key.

In weighing mode important factor is proper setting of level (level is located at the back) and calibration. Setting level is essential after each moving the device to a new working place.

**MENU** key opens a set of special functions. Standard functions are described below. Other special functions may be delivered on demand. *Setting default* option enables return to factory settings.

### 14.1 Units

In order to change the unit used in balance and moisture analyzer use **MENU** key, in *Configuration* window (*User Menu* window shows up when the normal weighing mode is off).

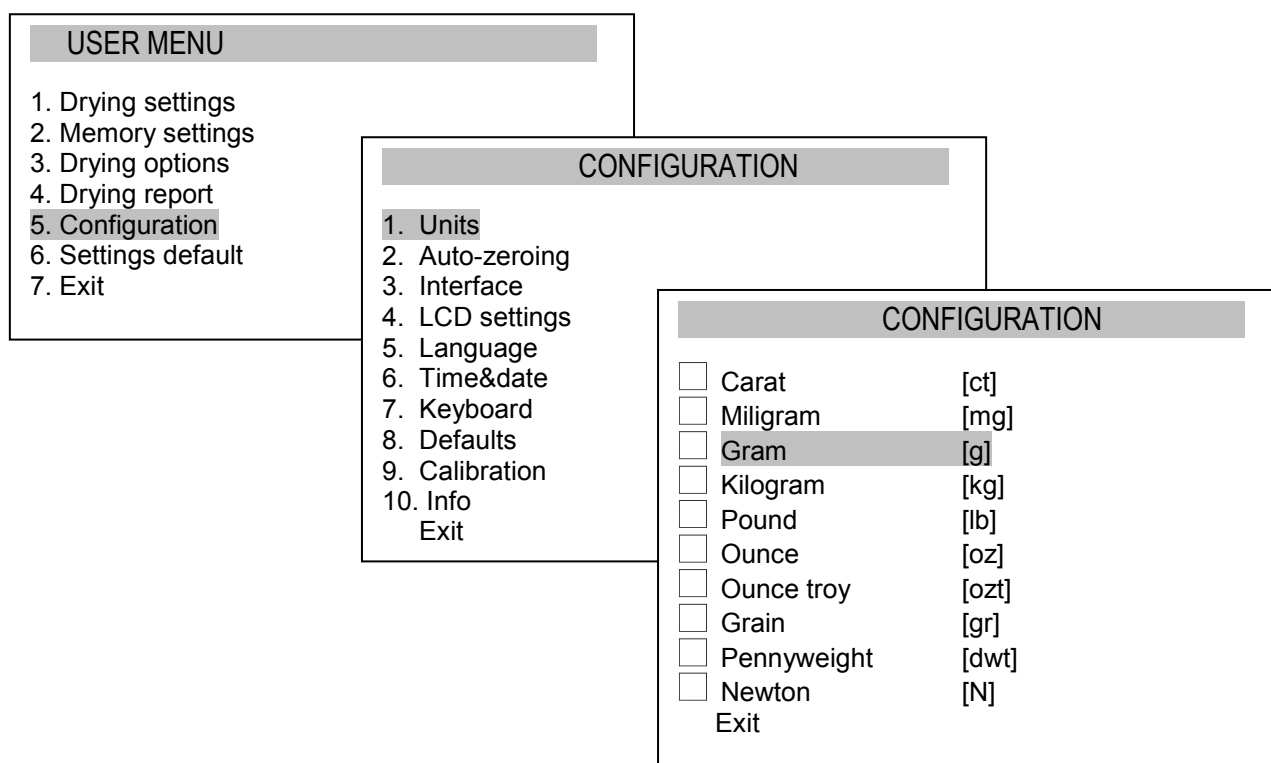

Choice of unit is made using navigation keys and ENTER key.

## 14.2 Auto-zeroing

Auto-zeroing function causes that the close to zero indication will be corrected automatically and when the pan is unbiased zero indication will be hold independently even when environment conditions change (temperature, air density etc).

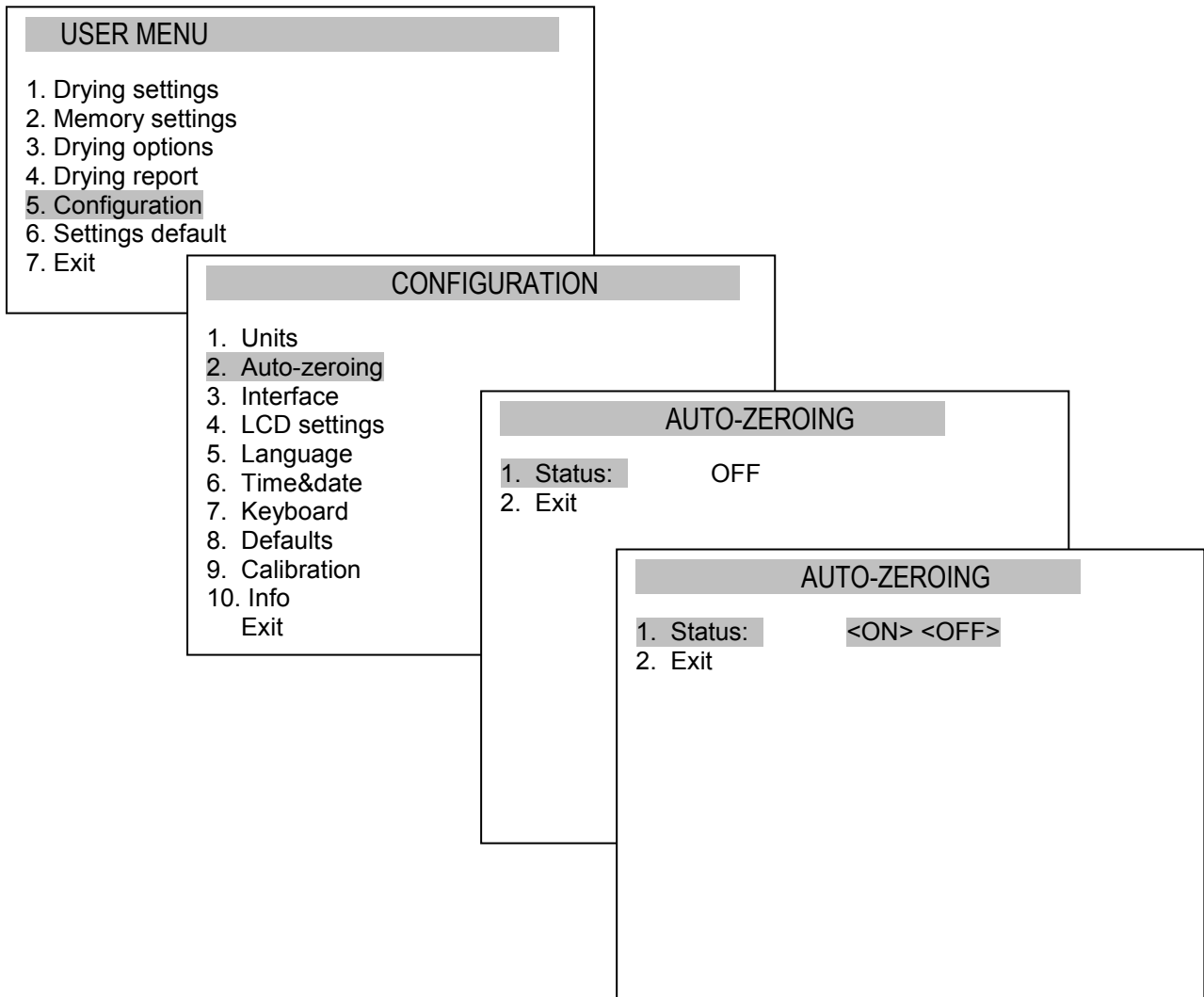

In order to turn on *Auto-zeroing* function use navigation keys and *ENTER* key, choose *Status ON*.



### 14.3 Calibration

Calibration with external weight standard should be performed in case indications exceed permissible error (for example more than 5 graduation overflow). To scale calibration use weight standard presented in technical data table (or more precise).

Depending on the value of gravity acceleration the producer sets the scale to specific location of use.

If the location of use change the scale should be calibrated once again

**Attention:** Scale sensitivity error doesn't cause directly humidity error thanks to percentage calculation formula.

In order to calibrate the balance use *MENU* key and *Configuration* option, and then *Calibration*.

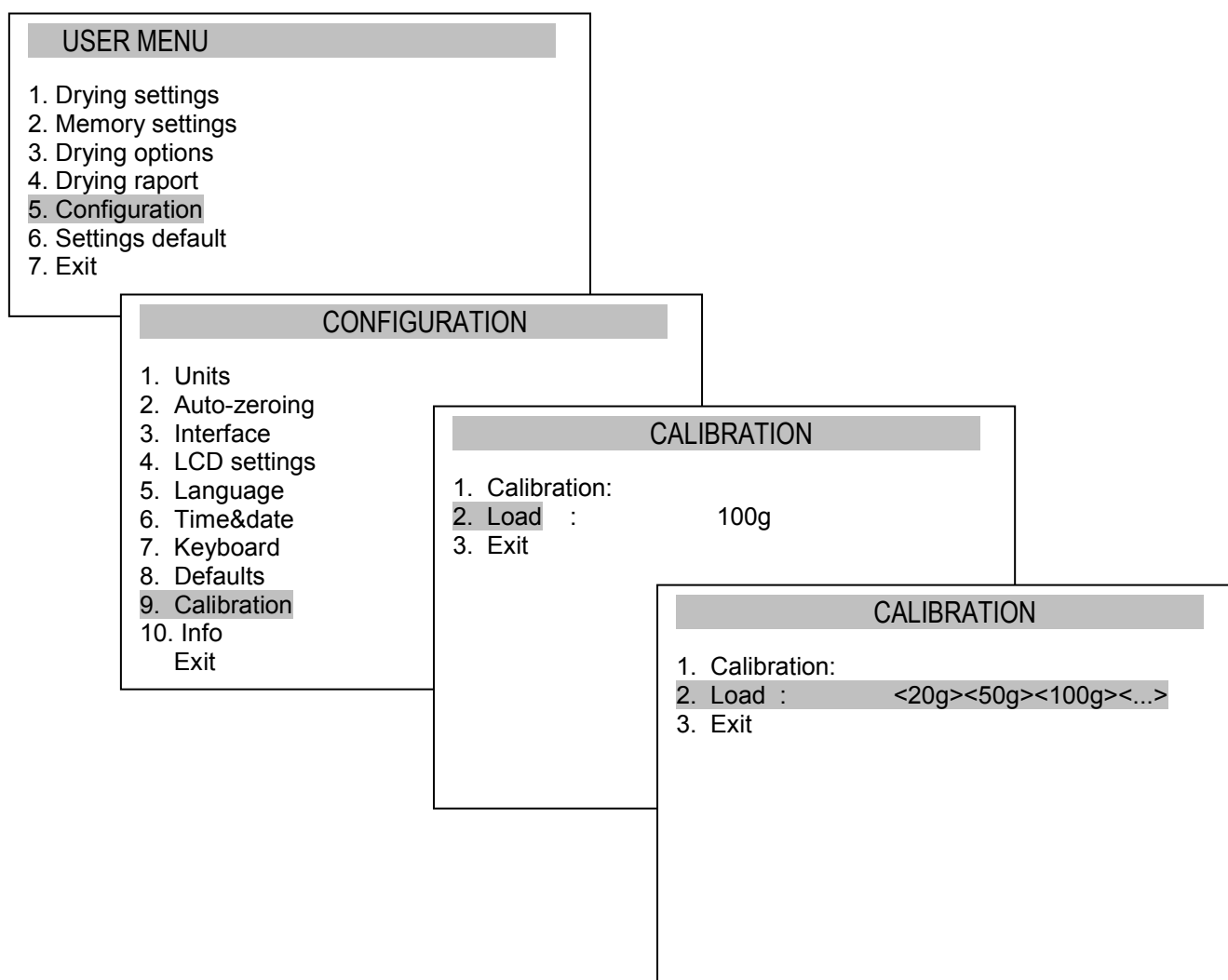

*Load* enables to inscribe standard mass value that will be used to calibrate. User can choose from few values or inscribe his own value.

After setting the standard of mass prepare single-use pan, put the standard and choose *Calibration* option by pressing *ENTER*.

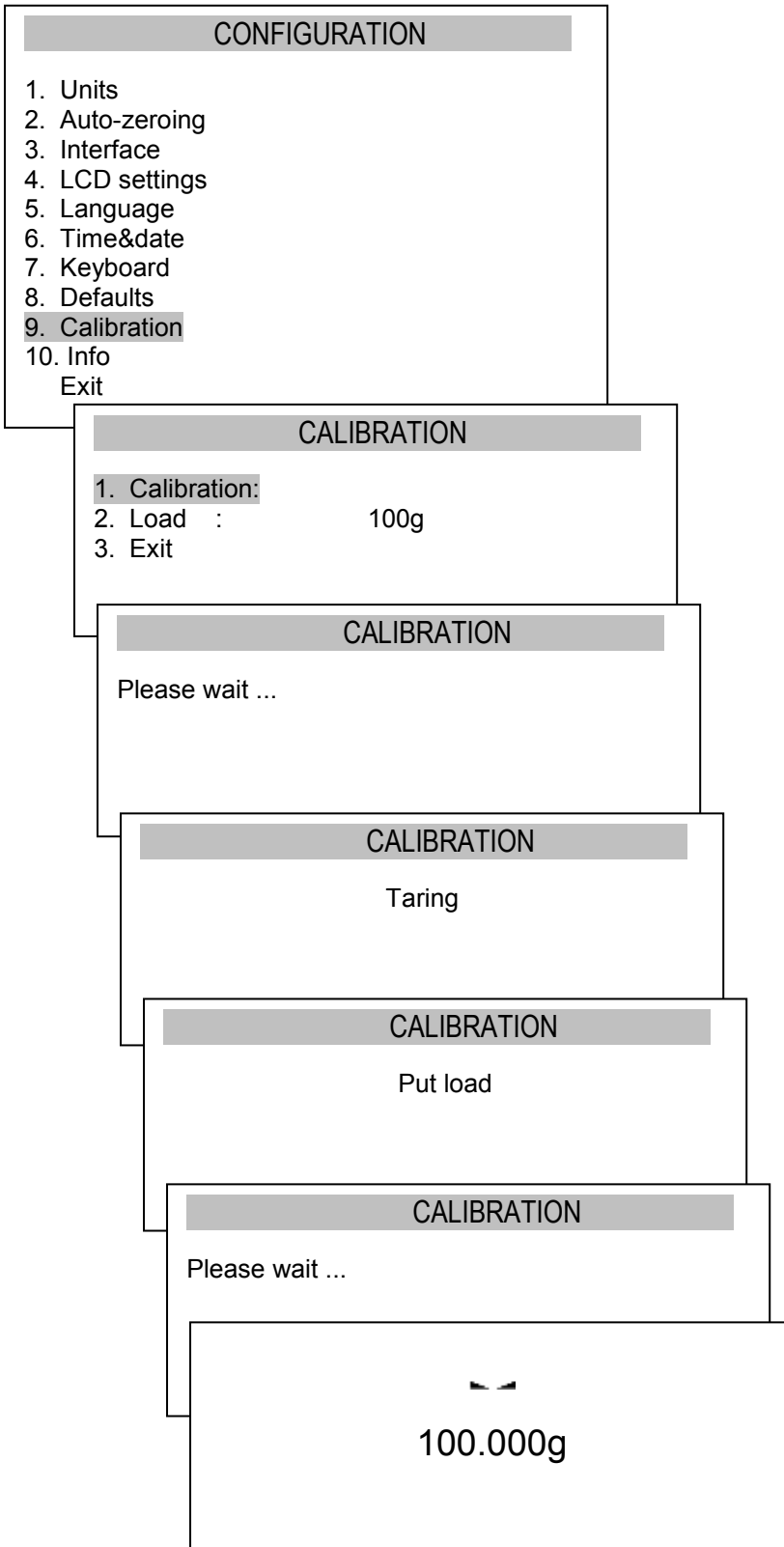

Put the standard of mass on the pan.

Displaying standard of mass value means that the calibration is done.

## 15. Maintenance and repairs of small defects

1. A moisture analyser should be kept clean.
2. Take care that no dirt gets between the casing and the pan. If found any, remove the pan (lift it up), remove dirt and then replace the pan.
3. In case of improper operation caused by a short-lasting power supply decay, unplug the moisture analyzer from the mains and then plug it again after few seconds.
4. It is forbidden to make any repairs by unauthorised persons.
5. To repair the moisture analyzer, please contact an authorised service centre. Moisture analyser can be sent for repair as messenger delivery only in original package, if not, there is a risk of damaging the moisture analyzer and loosing guarantee.

### *Measuring problems:*

Problem	Solution
A sample burns down	Reduce temperature Use glass fibre filter on the top of the sample Reduce sample quantity and distribute it uniformly
Drying lasts too long	Increase temperature Reduce sample mass
A sample loses weight before measurement	Take out the pan and put a sample outside the chamber
A sample is liquid or paste	Use glass fibre filter
A sample does not consist of enough volatile matters	Enlarge a sample

**Troubleshooting:**

<b>Display indication</b>	<b>Possible cause</b>	<b>Remedy</b>
Initial heating Ts temperature exceeds 105°C, the sensor does not react when touched with a finger	The temperature sensor is damaged.	Contact an authorised service point.
Initial heating Ts temperature does not reach 105°C, the halogen heater(s) do not light.	The heater is damaged.	Replace the heater.
"Test ..."	Auto-tests in progress / electronic unit damage	wait for 1 minute
" - - - - "	The moisture analyzer is during zeroing / mechanical damage	wait for 1 minute check if the moisture analyzer is placed on stable ground, not affected by vibrations
„Tare range exceeded”	Tare key pressed during zero indication	Moisture analyzer indications must be different than zero
„Zeroing range exceeded”	Permissible zeroing range was exceeded	Remove the load from the pan
„Weighing range exceeded”	Permissible weighing range (Max +9e) was exceeded	Reduce the load
„Measuring range exceeded (+)”	Upper limit of analog-digital transducer measuring range was exceeded	Remove the load from the pan
„Measuring range exceeded (-)”	Lower limit of analog-digital transducer measuring range was exceeded	Check if there are all necessary pan elements

# Declaration of Conformity

The last two digits of the year in which the CE marking was affixed: 15

We:

**AXIS** Spółka z o.o. 80-125 Gdańsk, ul.Kartuska 375B, Poland

confirm with all responsibility that moisture analysers:

AGS50 ,AGS60, AGS100, AGS120, AGS200, AGS210

AGS50/T250, AGS60/T250, AGS100/T250, AGS120/T250, AGS200/T250

AGS210/T250

marked with CE mark comply with the following:

1. EN 61010-1 standard *Safety requirements for electrical equipment for measurement, control and laboratory use. General requirements* harmonized with the directive 73/23/EEC (replaced by 2006/95/WE).
2. EN 55011:2001 + A2:2004 Electromagnetic compatibility (EMC) – Industrial, scientific and medical (ISM) radio-frequency equipment. Radio disturbance characteristics. Limits and methods of measurement and EN 61000-4-3:2003 + A1:2004(U) - Electromagnetic compatibility (EMC) - Part 4-3: Testing and measurement techniques - Radiated, radio-frequency, electromagnetic field immunity test harmonized with the directive 89/336/EEG (replaced by 2004/108/WE).

Additional information:

Conformity evaluation for the Council Directive 73/23/ECC and 89/336/EEC (replaced by 2006/95/WE and 2004/108/WE) was carried out by Laboratorium Badawcze Oddziału Instytutu Elektrotechniki in Gdańsk, accredited by PCA (reports from examinations No. 124/LBS-780/2005 and 131/LMC-780/2005).

Per pro Director of AXIS Sp. z o.o.:

Production Manager

Jan Kończak

  
\_\_\_\_\_

Date: 14-11-2014

### ***Drying parameters for different substances (examples)***

No	Substance	Initial weight (g)	Temperature (°C)	Preparation	Analysing time (min)
1.	Acrylate seal	3		mix a sample	9
2.	Granulated acryl	10-15	80		12
3.	Acryl ester	1.5		mix a sample	19
4.	Active coal	10	80		9.8
5.	Active coal	7.6	80		4.1
6.	Cream	1.5			10.9
7.	Cream	2			10.8
8.	Cotton seeds	3-4	110	grind a sample for 1 min.	6.3
9.	Cheese	2	160		13.3
10.	Bean	4.5	150	grind a sample	9.7
11.	Roasting sauce	2			6.1
12.	Butter	1.7	140	tear up a foil	4.3
13.	Cellulose acetan	5.5-6	50		1.3
14.	Photo paper	2	150	tear up in 1 cm <sup>3</sup> pieces	6.4
15.	Dialyse membrane	0.5	80	cut into thin slices	2.2
16.	Dialyse membrane	0.5-0.7	80	cut into thin slices	2
17.	Leak stopper	3	160		7
18.	Glue dissolvent	1.5	140		9.5
19.	Dolomite	10-12	160		6.1
20.	Drawing ink	1.5	120		10
21.	Pea	3.5	135	grind for 30 sec.	7.9
22.	Peanuts	2.8	100	grind into thick powder	4
23.	Peanuts	3	100	grind into thick powder	6
24.	Mint pastilles	3-3.4	90	grind into thick powder	2.9
25.	Powder paint	1.5	120		3.5
26.	Ceramics clay	2.5	160	cut into thin slices	9
27.	River water	4	160	mix a sample	20
28.	Icing sugar	5	130		20
29.	Dissolvent	2	155	mix a sample	7.6
30.	Cottage cheese	6	140	mix a sample	
31.	Feeding stuff	3-4	150		5.7
32.	Dry beans	3-4	105	grind a sample	5
33.	Dry peas	5-7	110	grind a sample for 10 sec.	9.6
34.	Dry carrot	5.5-6	120	grind a sample	3
35.	Dry chicken excrements	4	140		8
36.	Dry corn	5-7	110	grind a sample	10
37.	Glass powder	8-10	160		5
38.	Balsam	0.01	145		9
39.	Balsam	1	130		8
40.	Nuts	2.2	100	grind into thick powder	3.8
41.	Nuts in shells	2.6	100	grind into thick powder	4.5
42.	Soda bihydrate	1.6	160		12
43.	Coffee	2	150		8
44.	Instant coffee	5		mix a sample	10
45.	Coffee seeds	3.5-4	120	grind a sample for 1 min.	8
46.	Cocoa	2.5	105		4
47.	Cocoa	6		mix a sample	9
48.	Cocoa seeds	4-5	130	grind a sample for powder	7.8
49.	Limestone	12-14	160		5
50.	Dry potato pieces	2.5-3.0	130	divide a mass	5.8
51.	Ketchup	2	120		18
52.	Silicon gel	9.5	115		4.5
53.	Silicon acid	1.5		mix a sample	3
54.	Coal powder	4	160		3.4
55.	Natural chalk	8	160		1.7
56.	Synthetic chalk	6		mix a sample	4
57.	Granulated sugar	3	90		2.8
58.	Resin dissolvent	2	160	mix a sample	5.9

No	Substance	Initial weight (g)	Temperature (°C)	Preparation	Analysing time (min)
59.	Latex	1-2	160		5.2
60.	Latex LE1	3-5	125		10.8
61.	Latex LE2	3-5	125		9.4
62.	Latex O44	3-5	125		9.4
63.	Lentil	4	135	grind a sample for 30 sec.	5.4
64.	Loess soil	10-15	160		5.5
65.	Loess soil	2.5	160	cut into small pieces	14.5
66.	Skimmed milk	5	110	mix a sample	
67.	Skimmed milk powder	4	90		5.5
68.	Cottage cheese	1.2	130	mix a sample	8
69.	Corn starch	2	160		5.2
70.	Almonds with caramel	3.5	80	grind into thick powder	4.8
71.	Normal almonds	2.5	100	grind into thick powder	5.3
72.	Almonds	3	100	grind into thick powder	5.3
73.	Margarine	2.2	160		4
74.	Margarine	0.7	160		3.5
75.	Margarine	0.7	160		5
76.	Materials for bricks	7	160	distribute a sample	20
77.	Mikronyl	7-8	60		8
78.	Mikronyl	8	80		5
79.	Mikronyl	8	80		5
80.	Skimmed milk powder	4.5	100		6.3
81.	Fat milk powder	4.5	100		5.5
82.	Whey	5	110	mix a sample	
83.	Concentrated whey	2-3	90		10
84.	Mozzarella cheese	1.5	160		11.1
85.	Multivitamin bars	3-3.4	115	grind into thick powder	3.3
86.	Zeolite	3	160		
87.	Zeolite	3	160		
88.	Natural latex	1.4	160	mix a sample	5.3
89.	Chocolate	2.5	103		10
90.	Paste	0.55	160		5
91.	Concentrated orange juice	2-3	115	mix a sample	13
92.	Ultramid B3WG5	10	60		10
93.	Ultramid A3WG7	10	80		10
94.	Crastin SK645FR	10	80		10
95.	Macrolon	10-12	80		15
96.	Babyblend T65 MN	9-11	80		10
97.	Plexiglas 6N	10	70		10
98.	Polypropylene	13	130		9
99.	Polypropylene	3.3	120		2.2
100.	Polystyrene solution	2-2.5	120		8.7
101.	POM C9021	10	80		10
102.	Polystyrene 168 N	10	80		10
103.	Purine	2	105	mix a sample	3.8
104.	Cottage cheese	1	140	mix a sample	7
105.	Cheese 20%	2		mix a sample	12
106.	Fat cottage cheese	1.2	130	mix a sample	8
107.	Silicon sand	10-14	160		1.9
108.	Raclet cheese	1.5	160		14.4
109.	Oily seeds	3-4	90	grind a sample for 1 min	7.4
110.	Rice	3.5	105	grind a sample for 30 sec.	12.5
111.	Retentine	5	110	mix a sample	0.04
112.	Rye	4.5	150	grind a sample	11.5
113.	Beetroot	4.5	150	grind a sample	8.6
114.	Beetroot	4.5	150	grind a sample	8.9
115.	Beetroot	4.5	150	grind a sample	9.1
116.	Beetroot	4.5	150	grind a sample	8.5
117.	Sticks	3-4	75	grind into powder	4.5
118.	Processed cheese	1.5	70	tear up a foil	15
119.	Chocolate	2.5	103	cut into pieces	10
120.	Grinded chocolate	2-3	90		10
121.	Pig feeding stuff	4-5	160	mix a sample	21
122.	Speck	0.7	160		3.5
123.	Speck	0.8	160		3.5
124.	Soap	3	120	pinch some pieces	6

***Notes***