

NordicTrack[®] VGR970

Model No. NTEL11990

Serial No. _____

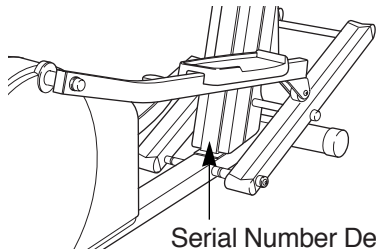

Serial Number Decal

USER'S MANUAL

QUESTIONS?

As a manufacturer, we are committed to providing complete customer satisfaction. If you have questions, or if there are missing parts, we will guarantee complete satisfaction through direct assistance from our factory.

TO AVOID UNNECESSARY DELAYS, PLEASE CALL DIRECT TO OUR TOLL-FREE CUSTOMER HOT LINE. The trained technicians on our customer hot line will provide immediate assistance, free of charge to you.

CUSTOMER HOT LINE:

1-888-825-2588

Mon.–Fri., 6 a.m.–6 p.m. MST

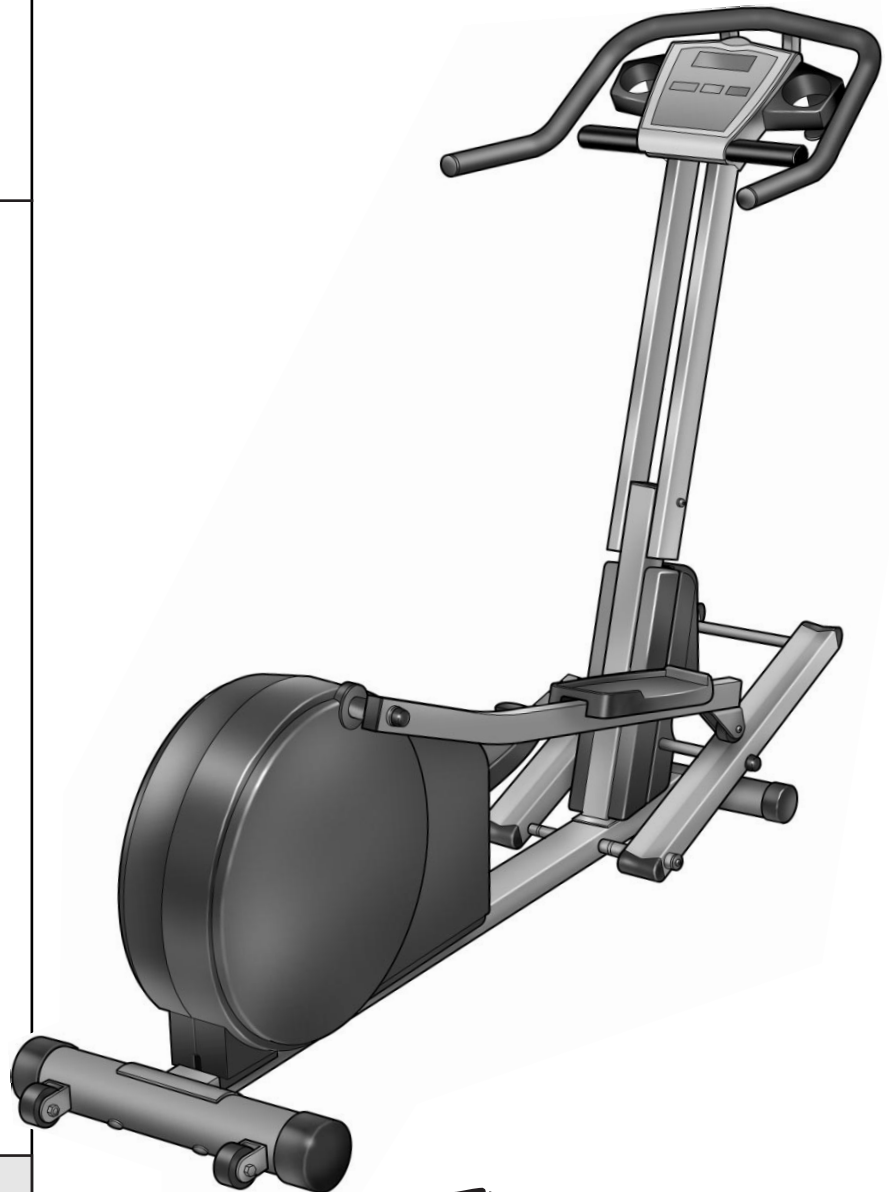

CAUTION

Read all precautions and instructions in this manual before using this equipment. Keep this manual for future reference.



Visit our website at

www.nordictrack.com

new products, prizes,
fitness tips, and much more!



NordicTrack[®]

VGR970

TABLE OF CONTENTS

IMPORTANT PRECAUTIONS	3
BEFORE YOU BEGIN	4
ASSEMBLY	5
HOW TO USE THE ELLIPTICAL CROSSTRAINER	9
MAINTENANCE	19
CONDITIONING GUIDELINES	20
PART LIST	22
EXPLODED DRAWING	23
HOW TO ORDER REPLACEMENT PARTSBack Cover
LIMITED WARRANTYBack Cover

IMPORTANT PRECAUTIONS

⚠ WARNING: To reduce the risk of serious injury, read the following important precautions before using the elliptical crosstrainer.

1. Read all instructions in this manual before using the elliptical crosstrainer.
2. It is the responsibility of the owner to ensure that all users of the elliptical crosstrainer are adequately informed of all precautions.
3. Place the elliptical crosstrainer on a level surface, with a mat beneath it to protect the floor or carpet. Keep the elliptical crosstrainer indoors, away from moisture and dust.
4. Inspect and tighten all parts regularly. Replace any worn parts immediately.
5. Keep children under the age of 12 and pets away from the elliptical crosstrainer at all times.
6. The elliptical crosstrainer should not be used by persons weighing more than 250 pounds.
7. Always hold the handlebar or the pulse handlebar when mounting, dismounting, or using the elliptical crosstrainer.
8. Wear appropriate exercise clothing when using the elliptical crosstrainer. Always wear athletic shoes for foot protection.
9. The pulse sensor is not a medical device. Various factors may affect the accuracy of heart rate readings. The pulse sensor is intended only as an exercise aid in determining heart rate trends in general.
10. When you stop exercising, allow the pedals to slowly come to a stop.
11. Keep your back straight when using the elliptical crosstrainer; do not arch your back.
12. If you feel pain or dizziness at any time while exercising, stop immediately and begin cooling down.
13. The elliptical crosstrainer is intended for in-home use only. Do not use the elliptical crosstrainer in a commercial, rental, or institutional setting.
14. The decal shown below has been placed on the elliptical crosstrainer. If the decal is missing or illegible, please call our Customer Service Department toll-free at 1-888-825-2588 to order a free replacement decal. Apply the decal in the location shown.

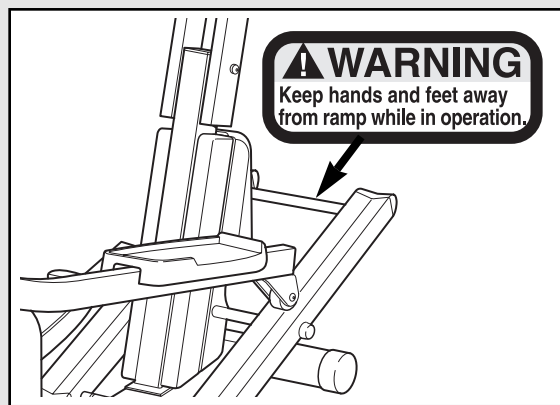

⚠ WARNING: Before beginning this or any exercise program, consult your physician. This is especially important for persons over the age of 35 or persons with pre-existing health problems. Read all instructions before using. ICON assumes no responsibility for personal injury or property damage sustained by or through the use of this product.

BEFORE YOU BEGIN

Congratulations for selecting the new NordicTrack® VGR970 elliptical crosstrainer. The NordicTrack® VGR970 is an incredibly smooth exerciser that moves your feet in a natural elliptical path, minimizing the impact on your knees and ankles. And the unique NordicTrack® VGR970 features adjustable resistance and incline to help you get the most from your exercise. Welcome to a whole new world of natural, elliptical-motion exercise from NordicTrack.



For your benefit, read this manual carefully before you use the NordicTrack® VGR970. If you have addi-

tional questions, please call our Customer Service Department toll-free at 1-888-825-2588, Monday through Friday, 6 a.m. until 6 p.m. Mountain Time (excluding holidays). To help us assist you, please note the product model number and serial number before calling. The model number is NTEL11990. The serial number can be found on a decal attached to the elliptical crosstrainer (see the front cover of this manual for the location of the decal).

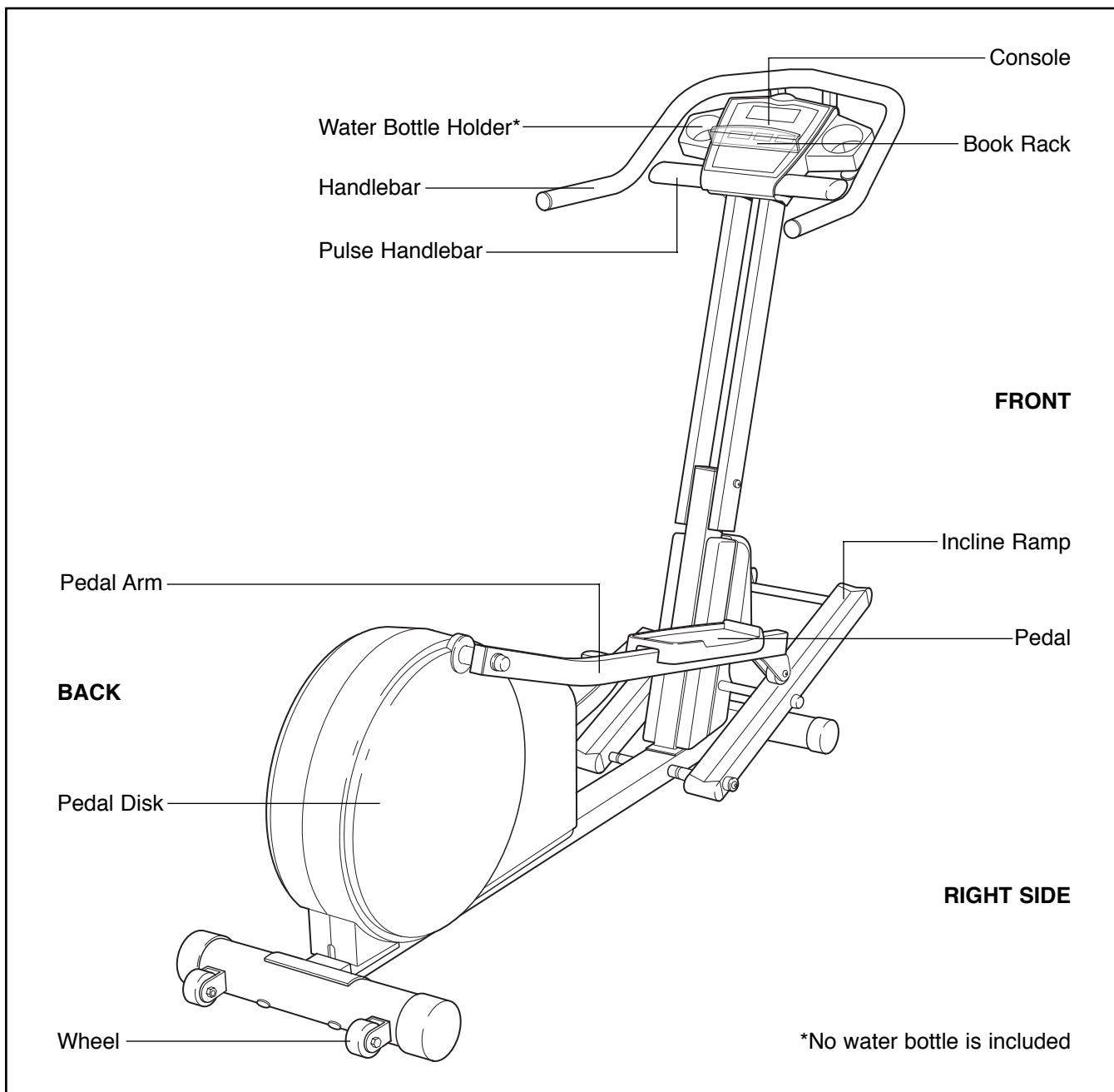
Before reading further, please familiarize yourself with the parts that are labeled in the drawing below.



ASSEMBLY

Assembly requires two people. Place all parts of the elliptical crosstrainer in a cleared area and remove the packing materials. Do not dispose of the packing materials until assembly is completed. **In addition to the included allen wrenches, assembly requires a phillips screwdriver** , **an adjustable wrench** , **and a rubber mallet** .

As you assemble the elliptical crosstrainer, use the drawings below to identify the small parts used in assembly. The number in parenthesis below each drawing refers to the key number of the part, from the PART LIST on page 22. The second number refers to the quantity used in assembly. **Note: Some small parts may have been pre-assembled for shipping. If a part is not in the parts bag, check to see if it has been pre-assembled.**

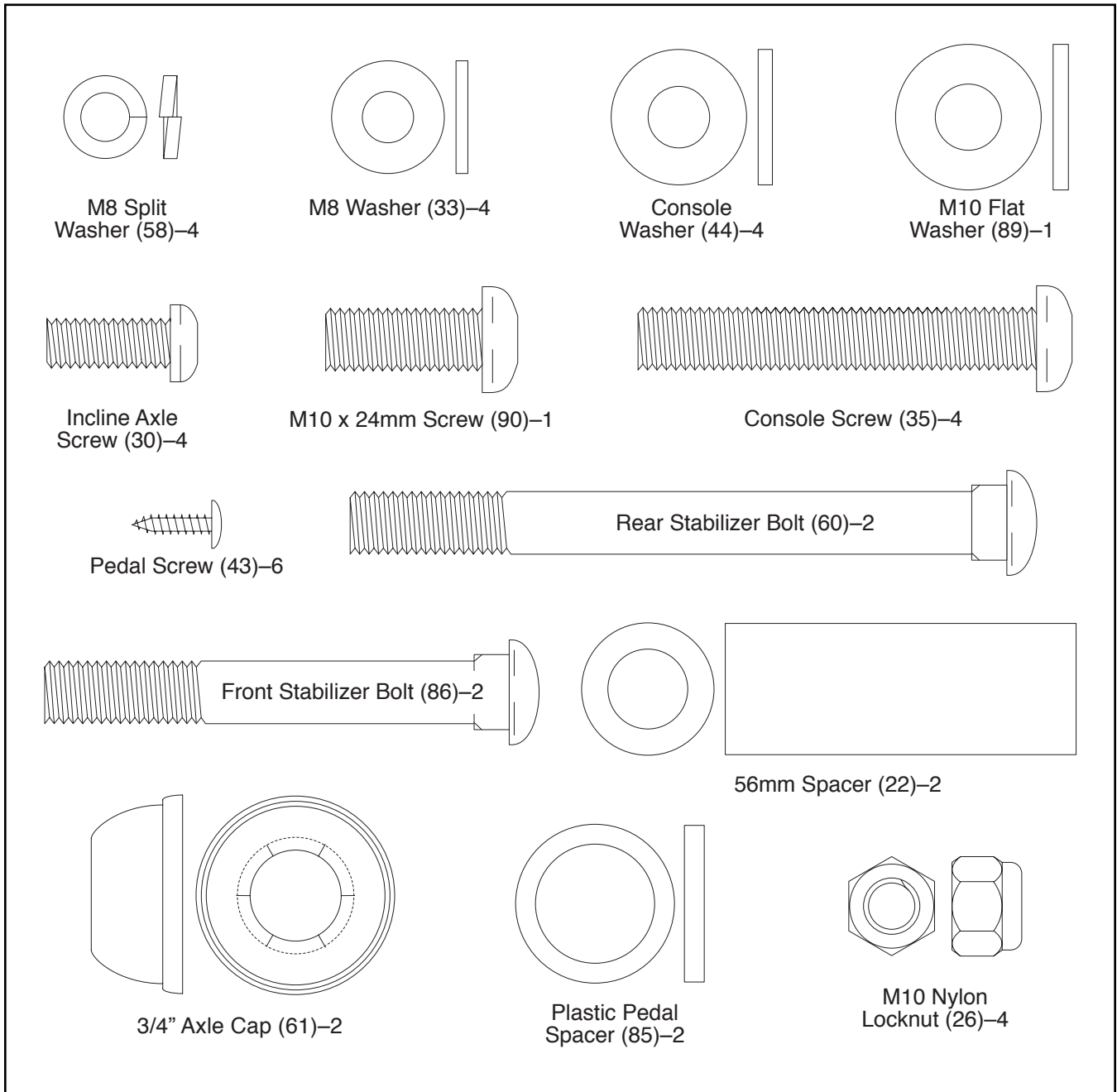

1. Identify the Rear Stabilizer (59), which has Wheels (45) attached to it.

Attach the Rear Stabilizer (59) to the rear of the Frame (1) with the two Rear Stabilizer Bolts (60) and two M10 Nylon Locknuts (26). **Make sure that the Rear Stabilizer is turned so the Wheels are not touching the floor.**

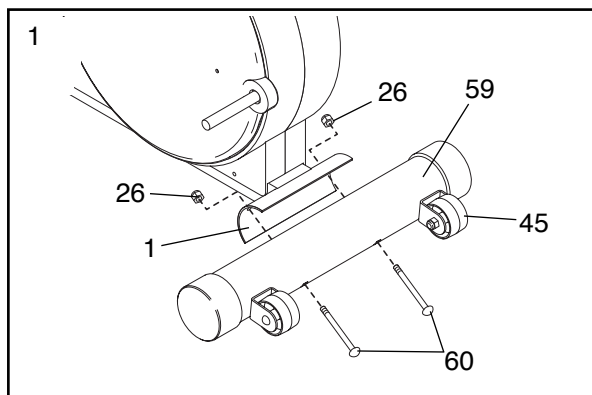

2. Attach the Front Stabilizer (14) to the front of the Frame (1) with the two Front Stabilizer Bolts (86) and two M10 Nylon Locknuts (26).

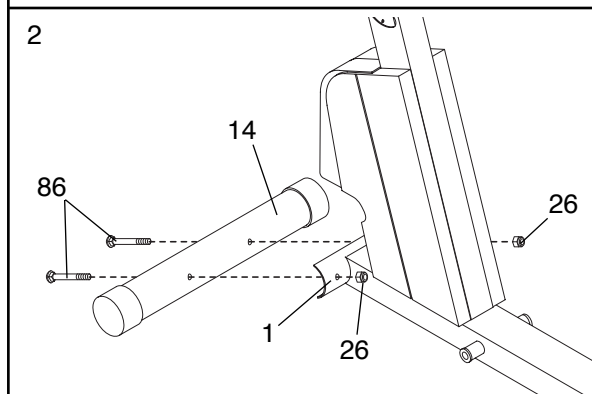

3. Slide an M8 Split Washer (58) and an M8 Washer (33) onto an Incline Axle Screw (30). Tighten the Incline Axle Screw into one end of an Incline Axle (29). Next, apply a small amount of the included grease to the Incline Axle.

Align the indicated tubes on the Incline Ramp (5) with the tubes on the Base (1). **Make sure that the Incline Ramp is turned so the V-shaped grooves are on top.** Insert the Incline Axle (29) through the Incline Ramp and the Base. Note: It may be helpful to tap the Incline Axle with a rubber mallet to insert it.

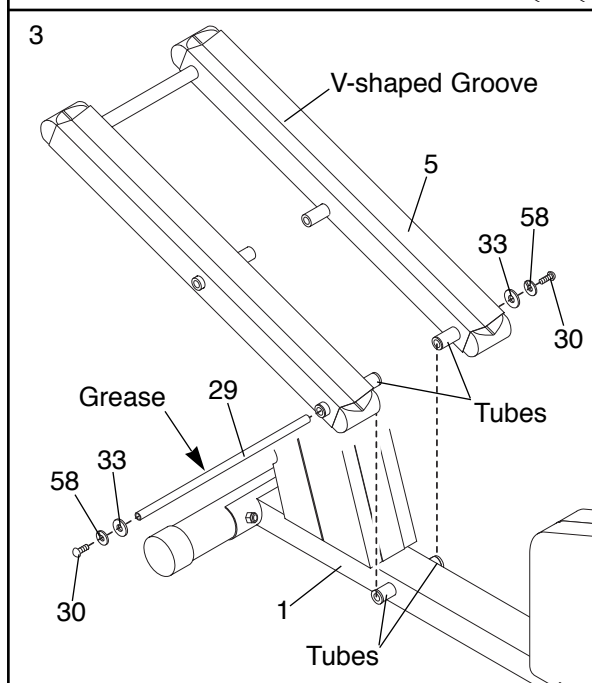

Slide an M8 Split Washer (58) and an M8 Washer (33) onto another Incline Axle Screw (30). Tighten the Incline Axle Screw into the open end of the Incline Axle (29).

4. Slide an M8 Split Washer (58) and an M8 Washer (33) onto an Incline Axle Screw (30). Tighten the Incline Axle Screw into one end of the other Incline Axle (29). Next, apply a small amount of grease to the Incline Axle.

Raise the Incline Ramp (5). Insert the Incline Axle (29) through one side of the Incline Ramp, through a 56mm Spacer (22), through the end of the motor screw, through another 56mm Spacer (22), and then through the other side of the Incline Ramp.

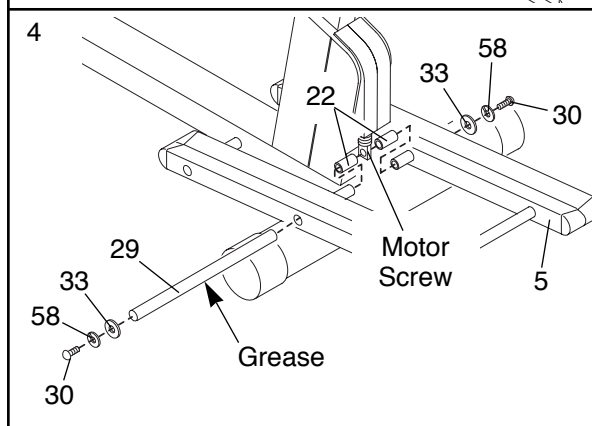

Slide an M8 Split Washer (58) and an M8 Washer (33) onto another Incline Axle Screw (30). Tighten the Incline Axle Screw into the open end of the Incline Axle (29).

5. Identify the Left Pedal Arm (3), which has an “L” sticker attached to it. Next, identify the Left Pedal (41), which has the letter “L” molded onto the bottom.

Turn over the Left Pedal Arm (3) as shown. Insert the three plastic posts on the Left Pedal (41) into the three indicated holes in the Left Pedal Arm. **Make sure that the Left Pedal is turned as shown.** Attach the Left Pedal with three Pedal Screws (43).

Attach the Right Pedal (not shown) to the Right Pedal Arm (not shown) in the same way.

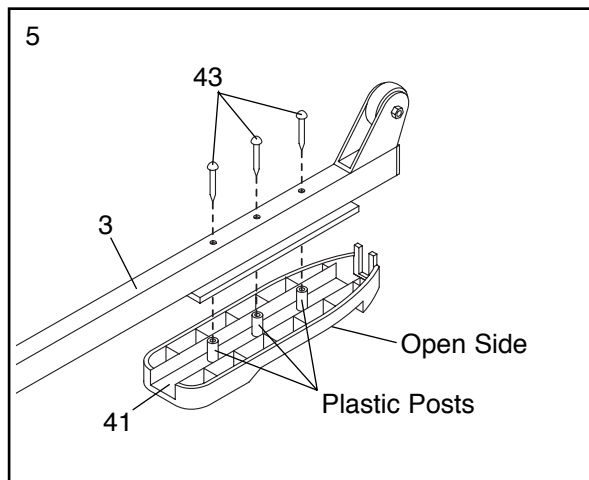

6. Apply a small amount of grease to the axle on the left Crank Arm (6).

Slide a Plastic Pedal Spacer (85) and the Left Pedal Arm (3) onto the axle on the left Crank Arm (6). Note: It may be helpful to use a rubber mallet to tap these parts on. **Be careful not to confuse the Left Pedal Arm with the Right Pedal Arm (not shown); look at the position of the round tube to correctly identify the Left Pedal Arm.** Next, tap a 3/4" Axle Cap (61) onto the axle.

Attach the Right Pedal Arm (not shown) in the same way.

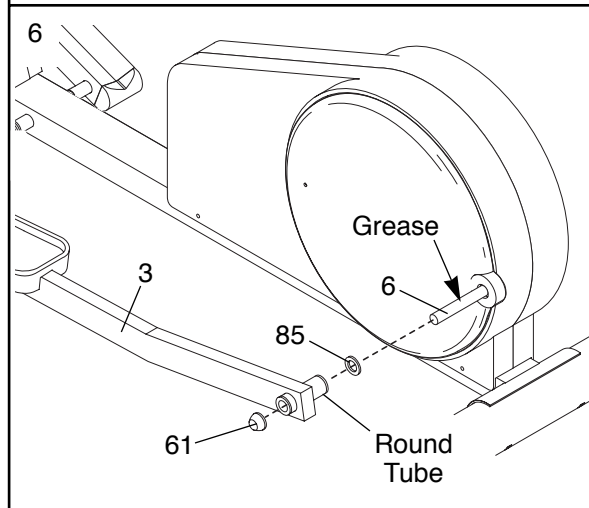

7. Carefully pivot the Upright (2) to the position shown. Secure the Upright by tightening the M10 x 24mm Screw (90) with the M10 Flat Washer (89) into the Upright and the Frame (1).

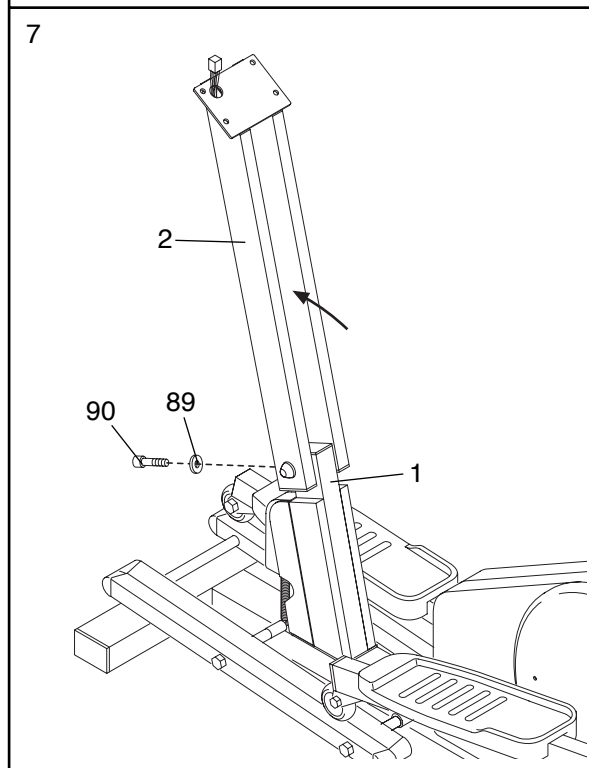

8. **This step requires the help of a second person.**

Remove the four Console Screws (35) and the four Console Washers (44) from the Console (87).

Hold the Console (87) in the position shown and connect the console wire harness to the Upper Wire Harness (51). Remove the rubber band from the Upper Wire Harness and push the Upper Wire Harness and the console wire harness down into the Upright (2). Set the Console on the Upright. **Make sure that the console wire harness is not pinched between the Console and the Upright.**

Hold the Handlebar (18) in the position shown. Align the four holes in the Handlebar with the four holes in the plate at the top of the Upright (2). Attach the Handlebar and the Console (87) to the Upright with the four Console Screws (35) and the four Console Washers (44) that you removed previously. Note: Thread all four Console Screws into the Console before tightening them.

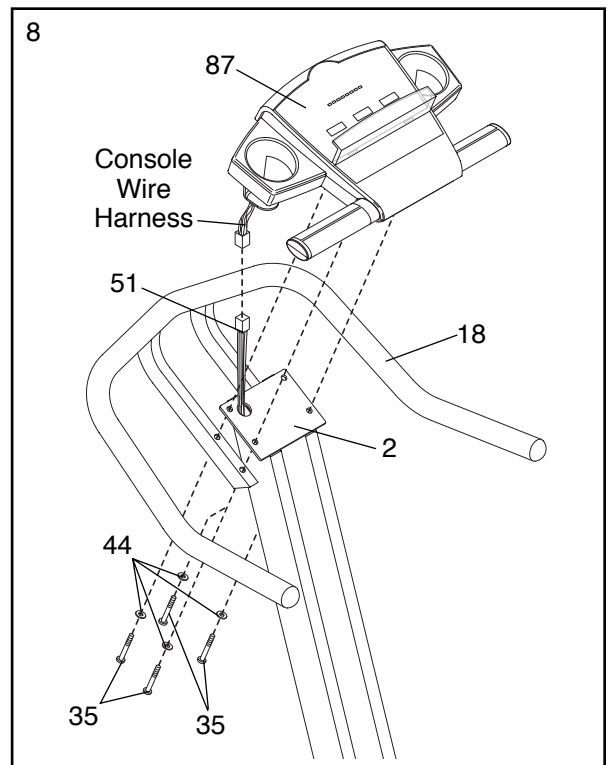

9. **Make sure that all parts of the elliptical crosstrainer are properly tightened. Note: Some hardware may be left over after assembly is completed.** To protect the floor or carpet from damage, place a mat under the elliptical crosstrainer.

HOW TO USE THE ELLIPTICAL CROSSTRAINER

HOW TO PLUG IN THE POWER CORD

Locate the power cord on the elliptical crosstrainer. Plug the power cord into an electrical outlet.

Note: Each time the power cord is plugged in, the resistance system will automatically calibrate itself. Calibration will take less than one minute. During calibration, the letters "CAL" will appear in the left LED display and the indicators in the TRAINING ZONE display will light in a rapid sequence.

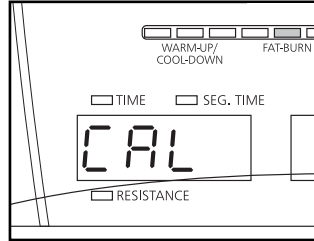

After the resistance system calibrates itself, the incline system may calibrate itself. During calibration, two dashes will appear in the center LED display and the indicators in the TRAINING ZONE display will light in a rapid sequence.

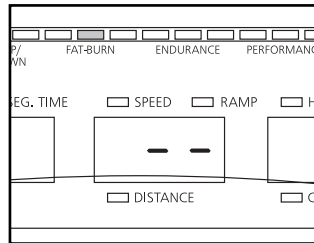

EXERCISING ON THE ELLIPTICAL CROSSTRAINER

To mount the elliptical crosstrainer, hold the handlebar and step onto the pedal that is in the lowest position. Next, step onto the other pedal. Push the pedals until they begin to move with a continuous motion.

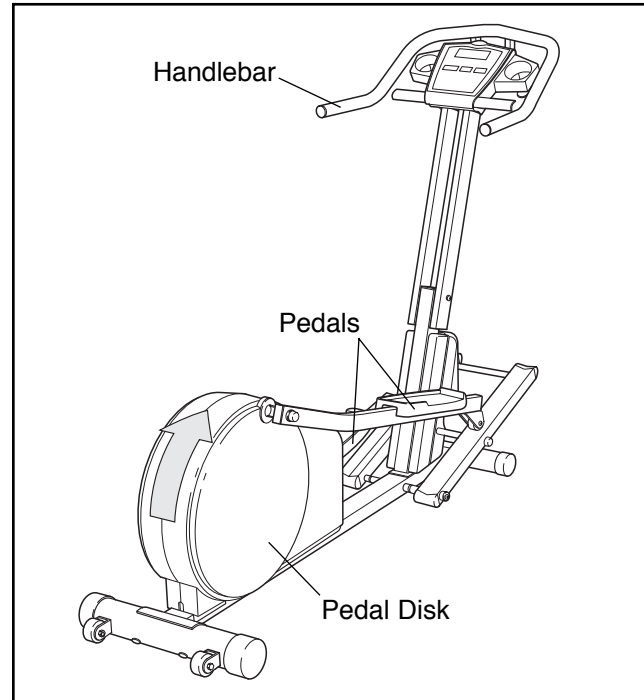

Note: The pedal disks can turn in either direction. It is recommended that you move the pedal disks in the direction shown by the arrow above; however, to give variety to your exercise, you may turn the pedal disks in the opposite direction.

To dismount the elliptical crosstrainer, wait until the pedals come to a complete stop. **Note: The elliptical crosstrainer does not have a freewheel; the pedals will continue to move until the flywheel stops.** When the pedals are stationary, step off the highest pedal first. Then, step off the lowest pedal.

DESCRIPTION OF THE CONSOLE

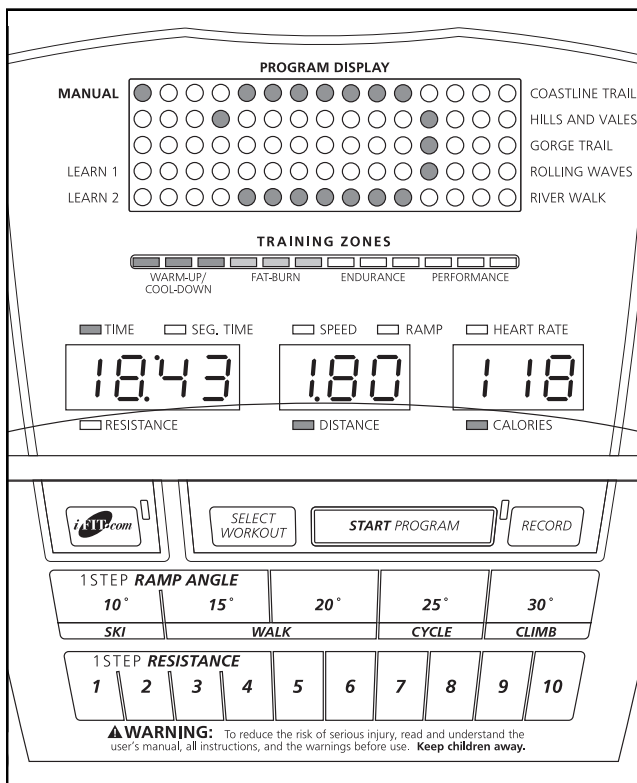

The advanced console offers a variety of features to help you get the most from your workouts.

When the manual mode of the console is selected, the angle of the ramp and the resistance of the pedals can be changed with a touch of a button. As you exercise, the program display, the training zone display, and the three LED displays will provide continuous exercise feedback. You can even measure your heart rate using the built-in pulse sensor.

In addition, the console offers five preset workout programs. Each program automatically changes the ramp angle and the resistance of the pedals as it guides you through an effective workout. You can even create your own workout programs and store them in memory for future use.

The console also features revolutionary iFit.com technology. iFit.com technology allows the console to play specially-designed CD's (available separately) that automatically control the ramp angle and the resistance of the pedals as a personal trainer coaches you through every step of your workout. High-energy music provides added motivation. Each CD features two workout programs designed by AFA™-certified personal trainers.

For information about iFit.com CD's, call toll-free 1-800-735-0768 or visit our Web site at www.iFit.com.

HOW TO USE THE MANUAL MODE

1 Make sure that the power cord is plugged in.

Refer to page 9.

2 Press any button on the console or move the pedals to turn on the power.

When one of the buttons on the console is pressed or the pedals are moved, various displays and indicators will light and the left LED display will begin to flash. Note: If the power cord was just plugged in, the power will already be on.

3 Select the manual mode.

When the power is turned on, the manual mode will be selected and the manual indicator will light. If you have selected a program or the iFit.com mode, press the SELECT WORKOUT button repeatedly until the manual indicator lights.

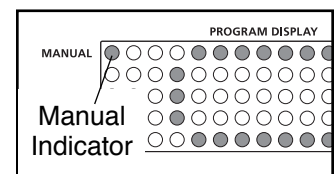

4 Begin exercising and adjust the resistance of the pedals as desired.

As you exercise, change the resistance of the pedals by pressing the RESISTANCE buttons. There are ten resistance levels; level 1 is the easiest. Note: After a RESISTANCE button is pressed, it will take a moment for the pedals to reach the selected resistance level.

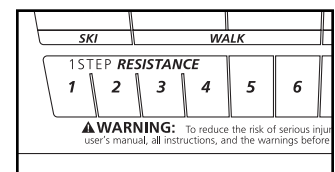

5 Adjust the angle of the ramp as desired.

To vary your exercise, change the angle of the ramp by pressing the RAMP ANGLE buttons. There are five angles that simulate skiing, walking, cycling, and climbing. Note: After a RAMP ANGLE button is pressed, it will take a moment for the ramp to reach the selected angle.



6 Watch your progress with the program display, the training zone display, and the LED displays.

The program display—When the manual mode or the iFit.com mode is selected, the program display will show a track representing 1/4 mile. As you exercise, the indicators around the track will light in sequence until the entire track is lit. A new lap will then begin.

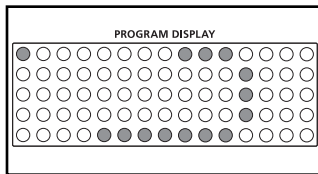

The training zone display—As you exercise, the training zone display will show the approximate intensity level of your exercise. For example, if four, five, or six indicators in the display are lit (refer to the drawing above), the display shows that your intensity level is ideal for fat burning.

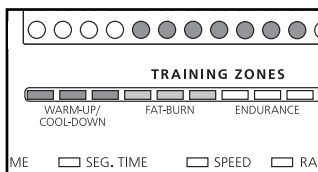

The left LED display—As you exercise, the left display will show the elapsed time and the current resistance level.



The display will change from one number to the other every six seconds, as shown by the indicators around the display. Note: When a program is selected, the left display will show the time remaining in the program, the time remaining in the current segment of the program, and the current resistance level.

Note: If you stop exercising for six seconds or longer, the console will pause and the left LED display will begin to flash.

The center LED display—As you exercise, the center display will show your current speed, the ramp angle, and the distance you have traveled. The display will change from one number to the next every six seconds, as shown by the indicators around the display.

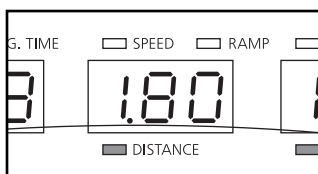

Note: Speed and distance can be shown in either miles or kilometers. To select the desired unit of measurement, refer to page 18.

The right LED display—As you exercise, the right display will show the approximate number of calories you have burned. This display will also show your heart rate when the pulse sensor is used (see step 7).

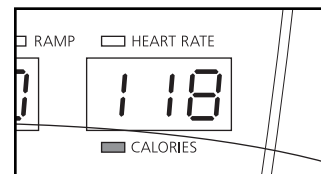

7 Measure your heart rate, if desired.

Note: If the metal contacts on the top and bottom of the pulse sensor are covered with clear vinyl strips, peel off the strips before using the pulse sensor.

To measure your heart rate, place your hands on the metal contacts on the pulse sensor. Your palms must be resting on the upper contacts and your fingers must be touching the lower contacts. **Avoid moving your hands.**

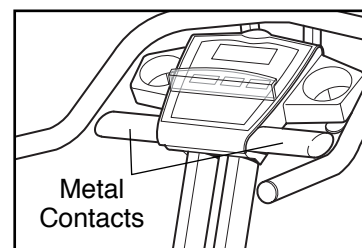

When your pulse is detected, the heart rate indicator above the right LED display will light, one to three dashes will appear in the display, and then your heart rate will be shown. For the most accurate heart rate reading, continue to hold the contacts for about 15 seconds. Note: If your heart rate is not shown, make sure that your hands are positioned as described above. Be careful not to move your hands excessively or squeeze the metal contacts too tightly.

Note: When you use the pulse sensor, the right display will show your heart rate for up to two minutes. If you continue to hold the pulse sensor, the display will show your heart rate along with the number of calories you have burned.

8 When you are finished exercising, turn off the power.

To turn off the power, simply wait for about ten minutes. **The console has an “auto-off” feature. If the console buttons are not pressed and the pedals are not moved for ten minutes, the console will turn off automatically.**

Note: If the displays and indicators remain lit after ten minutes, the console may be in the “demo” mode. Refer to the instructions on page 18 to turn off the demo mode.

HOW TO USE PRESET PROGRAMS

1 Make sure that the power cord is plugged in.

Refer to page 9.

2 Press any button on the console or move the pedals to turn on the power.

Refer to step 2 on page 10.

3 Select one of the five preset programs.

When the power is turned on, the manual mode will be selected and the manual indicator will light. To select a preset program, press the SELECT WORKOUT button repeatedly until one of the five preset program indicators lights.

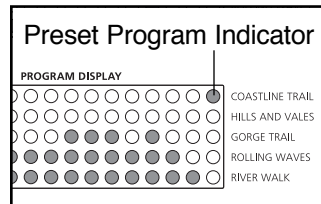

The graphs below show how the resistance will change during the five preset programs. (The ramp angle will also change during the programs; however, the ramp angle settings are not shown on the graphs.) Note: When a program is selected, the program display will show a simplified graph of the program.

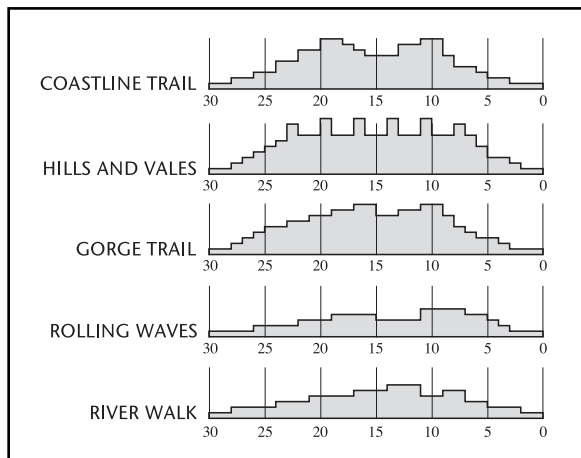

4 Press the START PROGRAM button and begin exercising.

Each program is divided into several individual segments. Each segment is one, two, three, or four minutes long. One resistance setting and one ramp angle setting are programmed for each segment. The resistance setting for the first segment will be shown in the flashing Current Segment column of the program display. The resistance

settings for the next ten segments will be shown in the ten columns to the right. (The ramp angle settings are not shown in the program display.)

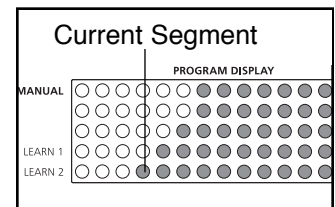

When only three seconds remain in the first segment of the program, both the Current Segment column and the column to the right will flash, a series of tones will sound, and all resistance settings will move one column to the left. The resistance setting for the second segment will then be shown in the flashing Current Segment column and the resistance of the pedals and the angle of the ramp will automatically adjust to the second settings. The program will continue in this way until the resistance setting for the last segment is shown in the Current Segment column and the last segment ends.

Note: Each time a segment ends and the resistance settings move to the left, if all of the indicators in the Current Segment column are lit, the resistance settings may move downward so that only the highest indicators in the columns will be shown in the program display. When the resistance settings move to the left again and not all of the indicators in the Current Segment column are lit, the resistance settings will move back up.

Note: You can manually override the resistance setting or the ramp angle setting for the current segment, if desired, by pressing the RESISTANCE or RAMP ANGLE buttons. However, **when the next segment of the program begins, the resistance of the pedals and the angle of the ramp will automatically adjust to the settings for the next segment.**

Note: If you stop exercising for six seconds or longer, the program will pause and the left LED display will begin to flash. To restart the program, simply resume exercising.

5 Watch your progress with the training zone display and the LED displays.

Refer to step 6 on page 11.

6 Measure your heart rate, if desired.

Refer to step 7 on page 11.

7 When the program is finished, turn off the power.

Refer to step 8 on page 11.

HOW TO CREATE A CUSTOM PROGRAM

1 Make sure that the power cord is plugged in.

Refer to page 9.

2 Press any button on the console or move the pedals to turn on the power.

Refer to step 2 on page 10.

3 Select one of the custom programs.

When the power is turned on, the manual mode will be selected and the manual indicator will light. To select a custom program, press the SELECT WORKOUT button repeatedly until one of the two custom program indicator lights.

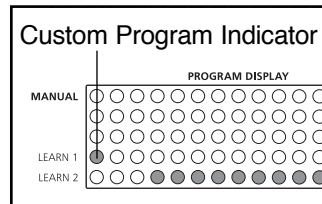

4 Press the START PROGRAM button and begin exercising.

5 Press the RECORD button and program the desired resistance and ramp angle settings.

When the RECORD button is pressed, the indicator beside the button will light. **Resistance and ramp angle settings can be programmed only when the indicator is lit.** Note: When the indicator beside the RECORD button is lit, the left LED display will show the elapsed time instead of the time remaining in the program.

Refer to the program display. Each custom program is divided into one-minute segments. One resistance setting and one ramp angle setting can be programmed for each segment. The resistance setting for the first segment will be shown in the flashing Current Segment column of the program display. (The ramp angle settings are not shown in the program display.) To program

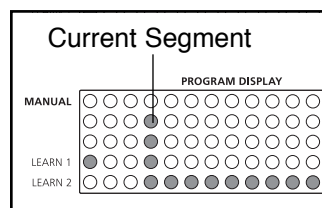

the desired resistance and ramp angle settings for the first segment, simply adjust the resistance of the pedals and the angle of the ramp as desired with the RESISTANCE and RAMP ANGLE buttons. As the resistance setting is increased, additional indicators will light in the Current Segment column of the program display. Note: While you are creating a custom program, the program display will show a maximum of five lit indicators, even if you program a higher resistance setting.

When the first segment of the program is completed, the current resistance setting and the current ramp angle setting will be stored in memory. All columns in the program display will then move one column to the left and the resistance setting for the second segment will be shown in the flashing Current Segment column. Program resistance and ramp angle settings for the second segment as described above.

Repeat this procedure until you have programmed resistance and ramp angle settings for as many segments as desired—custom programs can have up to forty segments.

Note: If you stop exercising for six seconds or longer, the program will pause and the left LED display will begin to flash. To restart the program, simply resume exercising.

6 Press the SELECT WORKOUT button to end the custom program.

When you have programmed resistance and ramp angle settings for as many segments as desired, press the SELECT WORKOUT button. The resistance and ramp angle settings that you programmed and the number of completed segments will be stored in memory. To use the custom program, see HOW TO USE CUSTOM PROGRAMS on page 14.

7 When the program is finished, turn off the power.

Refer to step 8 on page 11.

HOW TO USE CUSTOM PROGRAMS

1 Make sure that the power cord is plugged in.

Refer to page 9.

2 Press any button on the console or move the pedals to turn on the power.

Refer to step 2 on page 10.

3 Select one of the custom programs.

When the power is turned on, the manual mode will be selected and the manual indicator will light. To select a custom program, press the SELECT WORKOUT button repeatedly until one of the two custom program indicators lights.

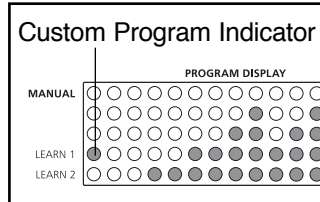

Note: When a custom program is selected, the program display will show a simplified graph of the program.

4 Press the START PROGRAM button and begin exercising.

When the program is started, the resistance of the pedals and the angle of the ramp will adjust to the first settings that you programmed previously.

Each program is divided into several individual segments. One resistance setting and one ramp angle setting are programmed for each segment. The resistance setting for the first segment will be shown in the flashing Current Segment column of the program display. The resistance settings for the next ten segments will be shown in the ten columns to the right. (The ramp angle settings are not shown in the program display.)

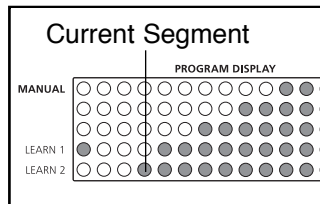

When only three seconds remain in the first segment of the program, both the Current Segment column and the column to the right will flash, a series of tones will sound, and all resistance settings will move one column to the left. The resistance setting for the second segment will then be shown in the flashing Current Segment column and the resistance of the pedals and the angle of the ramp will automatically adjust to the second settings that you programmed previously.

The program will continue in this way until the resistance setting for the last segment is shown in the Current Segment column and the last segment ends.

Note: If the program is too easy or too difficult, the resistance or ramp angle setting for the current segment can be adjusted with the RESISTANCE or RAMP ANGLE buttons. Adjustments will not be stored in memory. To **reprogram** the resistance or ramp angle setting for the current segment, press the RECORD button. The indicator beside the button will light. **Resistance and ramp angle settings can be programmed only when the indicator is lit.** Adjust the resistance or ramp angle setting for the current segment with the RESISTANCE or RAMP ANGLE buttons. After the segment is completed, press the RECORD button again. The new setting will be stored in memory.

Note: If you stop exercising for six seconds or longer, the program will pause and the left LED display will begin to flash. To restart the program, simply resume exercising.

5 Watch your progress with the training zone display and the LED displays.

Refer to step 6 on page 11.

6 Measure your heart rate, if desired.

Refer to step 7 on page 11.

7 When the program is finished, turn off the power.

Refer to step 8 on page 11.

HOW TO CONNECT YOUR CD PLAYER TO THE ELLIPTICAL CROSSTRAINER

To use iFit.com CD's (available separately), the elliptical crosstrainer must be connected to your portable CD player, portable stereo, home stereo, or computer with CD player. Refer to this page and page 16 for connecting instructions.

HOW TO CONNECT YOUR PORTABLE CD PLAYER

Note: If your CD player has separate LINE OUT and PHONES jacks, see instruction A below. If your CD player has only one jack, see instruction B.

- A. Plug one end of the audio cable into the jack beneath the console of the elliptical crosstrainer. Plug the other end of the cable into the LINE OUT jack on your CD player. Plug your headphones into the PHONES jack.

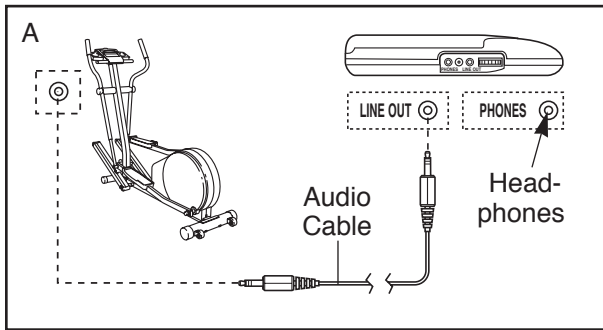

- B. Plug one end of the audio cable into the jack beneath the console of the elliptical crosstrainer. Plug the other end of the cable into a 3.5mm Y-adaptor (available at electronics stores). Plug the Y-adaptor into the PHONES jack on your CD player. Plug your headphones into the other side of the Y-adaptor.

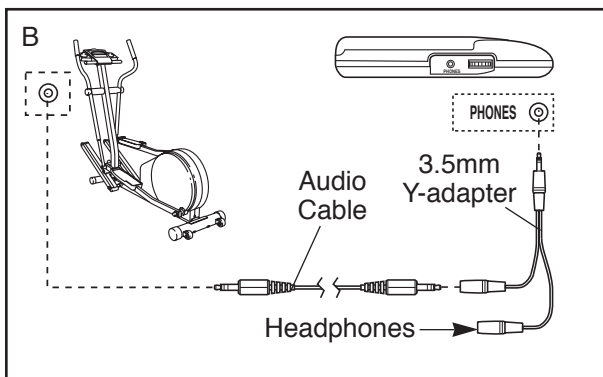

HOW TO CONNECT YOUR PORTABLE STEREO

Note: If your stereo has an RCA-type AUDIO OUT jack, see instruction A below. If your stereo has a 3.5mm LINE OUT jack, see instruction B. If your stereo has only a PHONES jack, see instruction C.

- A. Plug one end of the audio cable into the jack beneath the console of the elliptical crosstrainer. Plug the other end of the cable into the included adapter. Plug the adapter into an AUDIO OUT jack on your stereo.

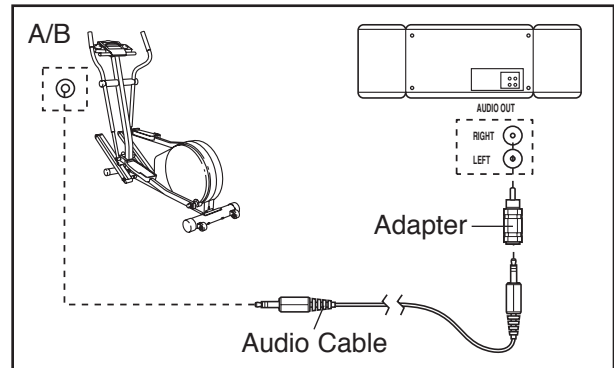

- B. Plug one end of the audio cable into the jack beneath the console of the elliptical crosstrainer. Plug the other end of the cable into the LINE OUT jack on your stereo. Do not use the adapter.

- C. Plug one end of the audio cable into the jack beneath the console of the elliptical crosstrainer. Plug the other end of the cable into a 3.5mm Y-adaptor (available at electronics stores). Plug the Y-adaptor into the PHONES jack on your stereo. Plug your headphones into the other side of the Y-adaptor.

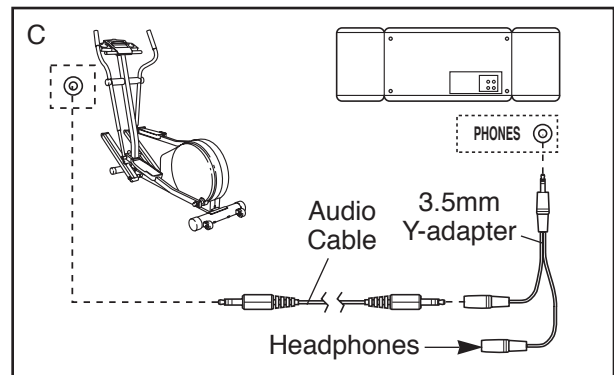

HOW TO CONNECT YOUR HOME STEREO

Note: If your stereo has an unused **LINE OUT** jack, see instruction **A** below. If the **LINE OUT** jack is being used, see instruction **B**.

- A. Plug one end of the audio cable into the jack beneath the console of the elliptical crosstrainer. Plug the other end of the cable into the included adapter. Plug the adapter into the **LINE OUT** jack on your stereo.

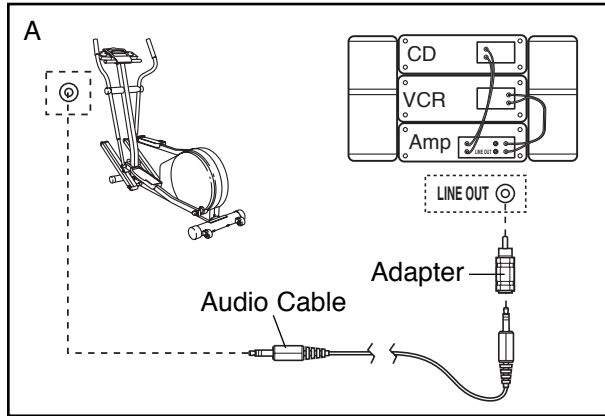

- B. Plug one end of the audio cable into the jack beneath the console of the elliptical crosstrainer. Plug the other end of the cable into the included adapter. Plug the adapter into an **RCA Y-adapter** (available at electronics stores). Next, remove the wire that is currently plugged into the **LINE OUT** jack on your stereo and plug the wire into the unused side of the **RCA Y-adapter**. Plug the **RCA Y-adapter** into the **LINE OUT** jack on your stereo.

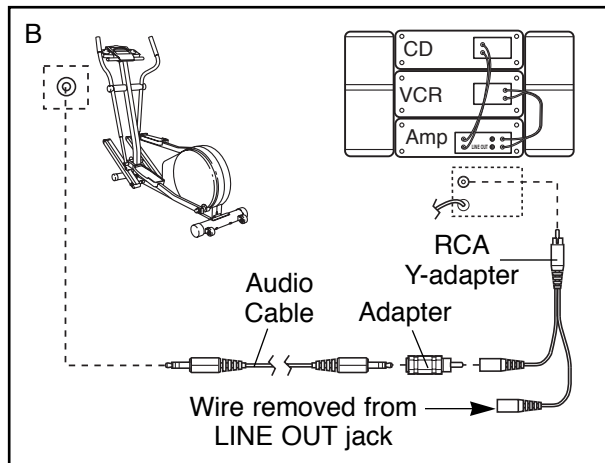

HOW TO CONNECT YOUR COMPUTER

Note: If your computer has a **3.5mm LINE OUT** jack, see instruction **A**. If your computer has only a **PHONES** jack, see instruction **B**.

- A. Plug one end of the audio cable into the jack beneath the console of the elliptical crosstrainer. Plug the other end of the cable into the **LINE OUT** jack on your computer.

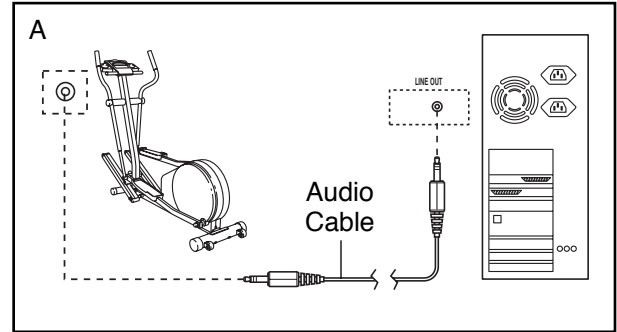

- B. Plug one end of the audio cable into the jack beneath the console of the elliptical crosstrainer. Plug the other end of the cable into a **3.5mm Y-adapter** (available at electronics stores). Plug the **Y-adapter** into the **PHONES** jack on your computer. Plug your headphones or speakers into the other side of the **Y-adapter**.

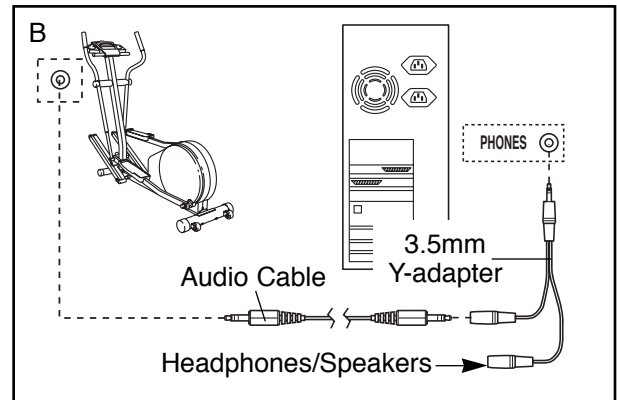

HOW TO USE IFIT.COM CD'S

iFit.com CD's (available separately) automatically control the resistance of the pedals as a personal trainer coaches you through every step of your workout. For information about purchasing CD's, call toll-free 1-800-999-3756.

Before using iFit.com CD's, you must connect the elliptical crosstrainer to your CD player. Refer to pages 15 and 16 for connecting instructions. Follow the steps below to use iFit.com CD's.

1 Make sure that the power cord is plugged in.

Refer to page 9.

2 Press any button on the console or move the pedals to turn on the power.

Refer to step 2 on page 10.

3 Select the iFit.com mode.

When the power is turned on, the manual mode will be selected and the manual indicator will light. To select the

iFit.com mode, press the IFIT.COM button. The indicator beside the button will light.

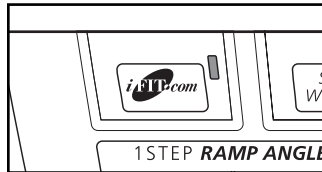

4 Insert the iFit.com CD into your CD player.

5 Press the play button on your CD player to start the program.

A moment after the play button is pressed, your personal trainer will begin guiding you through your workout. Simply follow your personal trainer's instructions.

During the CD program, the resistance of the pedals and the angle of the ramp will automatically change according to the settings of the program. An electronic "chirping" sound will alert you when the resistance and/or ramp angle is about to change. If the resistance or ramp angle setting is too high or too low, you can manually override the setting at any time by pressing the RESISTANCE or RAMP ANGLE buttons on the console. However, when the next "chirp" is heard, the resistance and/or ramp angle will change to the next setting for the program.

Note: If the resistance of the pedals and/or the angle of the ramp does not change when a "chirp" is heard:

- make sure that the indicator on the IFIT.COM button is lit
- adjust the volume of your CD player. If the volume is too high or too low, the console may not detect the program signals
- make sure that the audio cable is properly connected and that it is fully plugged in.

6 Watch your progress with the program display, the training zone display, and the LED displays.

Refer to step 6 on page 11.

7 Measure your heart rate, if desired.

Refer to step 7 on page 11.

8 When the program is finished, turn off the power.

Refer to step 8 on page 11.

THE INFORMATION MODE/DEMO MODE

The console features an information mode that keeps track of the total number of hours that the elliptical crosstrainer has been used and the total number of miles that the pedals have moved. The information mode also allows you to switch the console from miles to kilometers. In addition, the information mode allows you to turn on and turn off the demo mode.

To select the information mode, press RESISTANCE button “1” and the SELECT WORKOUT button at the same time. The following information will be shown:

The left LED display will show the total number of hours that the elliptical crosstrainer has been used.

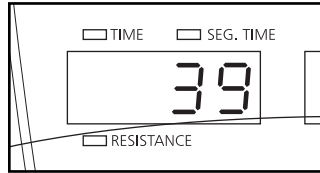

The center LED display will show the total number of miles that the pedals have moved.

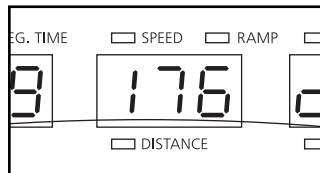

The right LED display will show an “E” for English miles or an “M” for metric kilometers. Press the START PROGRAM button to change the unit of measurement, if desired.

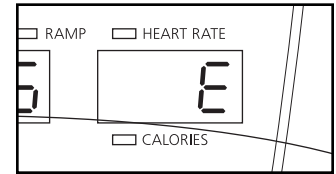

IMPORTANT: Make sure that there is not a “d” in the right display. If a “d” appears in the display, the console is in the “demo” mode.

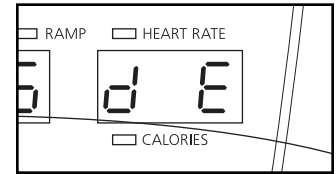

This mode is intended to be used only when an elliptical crosstrainer is displayed in a store. When the console is in the demo mode, the power cord can be plugged in and the displays and indicators on the console will automatically light in a preset sequence, although the buttons on the console will not operate. **If a “d” appears in the right display when the information mode is selected, press the SELECT WORKOUT button so the “d” disappears.**

To exit the information mode, press RESISTANCE button “1” and the SELECT WORKOUT button at the same time.

MAINTENANCE

For smooth operation of the elliptical crosstrainer, the incline ramp should be kept clean. Using a soft cloth and mild detergent, clean dust and other residue

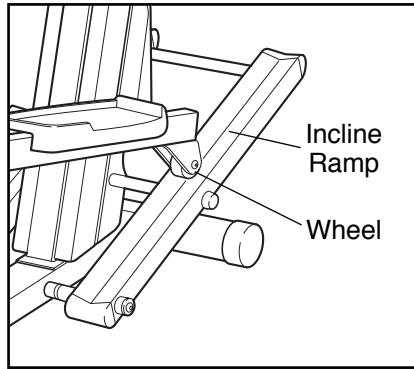

from the incline ramp where the wheels make contact with it. Other parts of the elliptical crosstrainer can also be cleaned in this manner. **Never use abrasives or solvents.**

Inspect and tighten all parts of the elliptical crosstrainer regularly. Replace any worn parts immediately.

CONDITIONING GUIDELINES

The following guidelines will help you to plan your exercise program. Remember that proper nutrition and adequate rest are essential for successful results.



WARNING:

Before beginning this or any exercise program, consult your physician. This is especially important for persons over the age of 35 or persons with pre-existing health problems.

The pulse sensor is not a medical device. Various factors may affect the accuracy of heart rate readings. The pulse sensor is intended only as an exercise aid in determining heart rate trends in general.

EXERCISE INTENSITY

Whether your goal is to burn fat or to strengthen your cardiovascular system, the key to achieving the desired results is to exercise with the proper intensity. The proper intensity level can be found by using your heart rate as a guide. The chart below shows recommended heart rates for fat burning, maximum fat burning, and cardiovascular (aerobic) exercise.

165	155	145	140	130	125	115	
145	138	130	125	118	110	103	
125	120	115	110	105	95	90	
20	30	40	50	60	70	80	

To find the proper heart rate for you, first find your age on the bottom line of the chart (ages are rounded off to the nearest ten years). Next, find the three numbers above your age. The three numbers are your “training zone.” The lowest number is the recommended heart rate for fat burning; the middle number is the recommended heart rate for maximum fat burning; the highest number is the recommended heart rate for aerobic exercise.

To measure your heart rate, first exercise for at least four minutes. Then, measure your heart rate using the pulse sensor (see step 7 on page 11).

Fat Burning

To burn fat effectively, you must exercise at a relatively low intensity level for a sustained period of time. During the first few minutes of exercise, your body uses easily accessible carbohydrate calories for energy. Only after the first few minutes of exercise does your body begin to use stored fat calories for energy. If your goal is to burn fat, adjust the intensity of your exercise until your heart rate is near the lowest number in your training zone as you exercise.

For maximum fat burning, adjust the intensity of your exercise until your heart rate is near the middle number in your training zone as you exercise.

Aerobic Exercise

If your goal is to strengthen your cardiovascular system, your exercise must be “aerobic.” Aerobic exercise is activity that requires large amounts of oxygen for prolonged periods of time. This increases the demand on the heart to pump blood to the muscles, and on the lungs to oxygenate the blood. For aerobic exercise, adjust the intensity of your exercise until your heart rate is near the highest number in your training zone.

WORKOUT GUIDELINES

Each workout should include the following three important parts:

A warm-up, consisting of 5 to 10 minutes of stretching and light exercise (see SUGGESTED STRETCHES on page 21). A proper warm-up increases your body temperature, heart rate, and circulation in preparation for exercise.

Training zone exercise, consisting of 20 to 30 minutes of exercising with your heart rate in your training zone. (During the first few weeks of your exercise program, do not keep your heart rate in your training zone for longer than 20 minutes.)

A cool-down, with 5 to 10 minutes of stretching. This will increase the flexibility of your muscles and will help to prevent post-exercise problems.

To maintain or improve your condition, complete three workouts each week, with at least one day of rest between workouts. After a few months of regular exercise, you may complete up to five workouts each week if desired. The key to success is to make exercise a regular and enjoyable part of your everyday life.

SUGGESTED STRETCHES

The correct form for several basic stretches is shown below. Move slowly as you stretch—never bounce.

1. Toe Touch Stretch

Stand with your knees bent slightly and slowly bend forward from your hips. Allow your back and shoulders to relax as you reach down toward your toes as far as possible. Hold for 15 counts, then relax. Repeat 3 times. Stretches: Hamstrings, back of knees and back.

2. Hamstring Stretch

Sit with one leg extended. Bring the sole of the opposite foot toward you and rest it against the inner thigh of your extended leg. Reach toward your toes as far as possible. Hold for 15 counts, then relax. Repeat 3 times for each leg. Stretches: Hamstrings, lower back and groin.

3. Calf/Achilles Stretch

With one leg in front of the other, reach forward and place your hands against a wall. Keep your back leg straight and your back foot flat on the floor. Bend your front leg, lean forward and move your hips toward the wall. Hold for 15 counts, then relax. Repeat 3 times for each leg. To cause further stretching of the achilles tendons, bend your back leg as well. Stretches: Calves, achilles tendons and ankles.

4. Quadriceps Stretch

With one hand against a wall for balance, reach back and grasp one foot with your other hand. Bring your heel as close to your buttocks as possible. Hold for 15 counts, then relax. Repeat 3 times for each leg. Stretches: Quadriceps and hip muscles.

5. Inner Thigh Stretch

Sit with the soles of your feet together and your knees outward. Pull your feet toward your groin area as far as possible. Hold for 15 counts, then relax. Repeat 3 times. Stretches: Quadriceps and hip muscles.

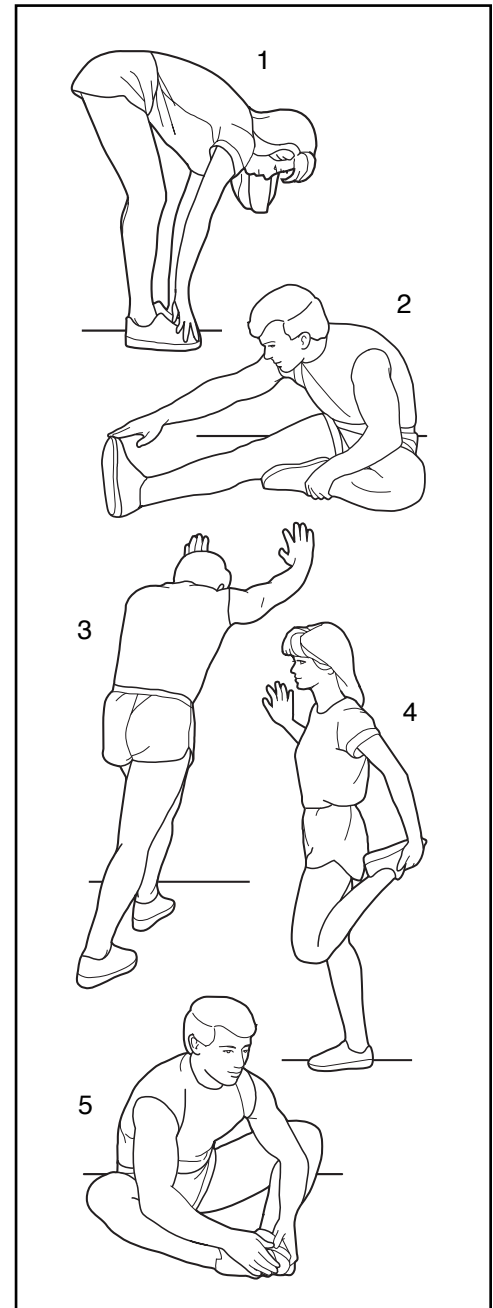

PART LIST—Model No. NTEL11990

R0100A

Key No.	Qty.	Description	Key No.	Qty.	Description
1	1	Frame	53	1	Resistance Cable
2	1	Upright	54	1	Reed Switch Clamp
3	1	Left Pedal Arm	55	1	Magnet
4	1	Right Pedal Arm	56	1	“C” Magnet
5	1	Incline Ramp	57	1	Stop Bolt
6	2	Crank Arm	58	6	M8 Split Washer
7	1	Power Cord	59	1	Rear Stabilizer
8	1	Large Pulley	60	2	Rear Stabilizer Bolt
9	2	Frame Bearing	61	2	3/4” Axle Cap
10	1	Plastic Crank Spacer	62	2	Front Stabilizer Endcap
11	1	Flat Delrin Washer	63	4	Pedal Arm Cap
12	1	Idler Bracket	64	2	Rear Stabilizer Endcap
13	4	Nut	65	1	“J” Bolt Nut
14	1	Front Stabilizer	66	1	“J” Bolt
15	2	Upright Endcap	67	2	M10 Nylon Jam Nut
16	1	Idler Arm Screw	68	1	Eyebolt
17	2	M10 Flat Washer	69	1	M6 Nylon Locknut
18	1	Handlebar	70	1	Adjustment Bracket
19	1	Arm Axle	71	1	M4 x 63.5mm Screw
20	2	Handlebar Endcap	72	10	M4 x 16mm Screw
21	1	Incline Motor	73	8	M5 x 16mm Screw
22	2	56mm Spacer	74	1	Frame Endcap
23	1	Incline Reed Switch	75	1	Left Incline Side Shield
24	1	Side Shield Support	76	4	Pedal Bushing
25	1	Wire Harness	77	2	Pedal Wheel
26	13	M10 Nylon Locknut	78	1	Right Incline Side Shield
27	1	Reed Switch Lock	79	2	Pedal Wheel Bolt
28	1	Belt	80	3	M8 Nylon Locknut
29	2	Incline Axle	81	4	M8 Black Washer
30	6	Incline Axle Screw	82	4	Wheel Spacer
31	6	Incline Bushing	83	2	Flange Bolt
32	4	Incline Ramp Cap	84	1	Grommet
33	6	M8 Washer	85	2	Plastic Pedal Spacer
34	1	Upright Axle	86	2	Front Stabilizer Bolt
35	4	Console Screw	87	1	Console
36	1	Spring	88	4	M5 x 25mm Screw
37	1	Flywheel	89	1	M10 Flat Washer
38	2	Flywheel Bearing	90	1	M10 x 24mm Screw
39	1	Flywheel Axle	91	1	Incline Bolt
40	2	Pedal Disk	92	2	Incline Washer
41	1	Left Pedal	93	2	Incline Spacer
42	1	Right Pedal	94	1	Incline Nut
43	6	Pedal Screw	95	4	Tree Fastener
44	4	Console Washer	96	2	Incline Side Shield Screw
45	2	Wheel	97	5	#8 x 1” Screw
46	2	Wheel Bolt	98	1	Junction Box/Cover
47	1	Left Side Shield	99	1	Wiring Board
48	1	Right Side Shield	100	1	Zip Tie
49	1	Console Base	101	1	#8 x 1/2” Zip Screw
50	1	Reed Switch/Wire	#	1	Grease
51	1	Upper Wire Harness	#	2	Allen Wrench
52	1	Reed Switch Bracket	#	1	User’s Manual

Note: # indicates a non-illustrated part. Specifications are subject to change without notice.

EXPLODED DRAWING — Model No. NTEL11990

R0100A

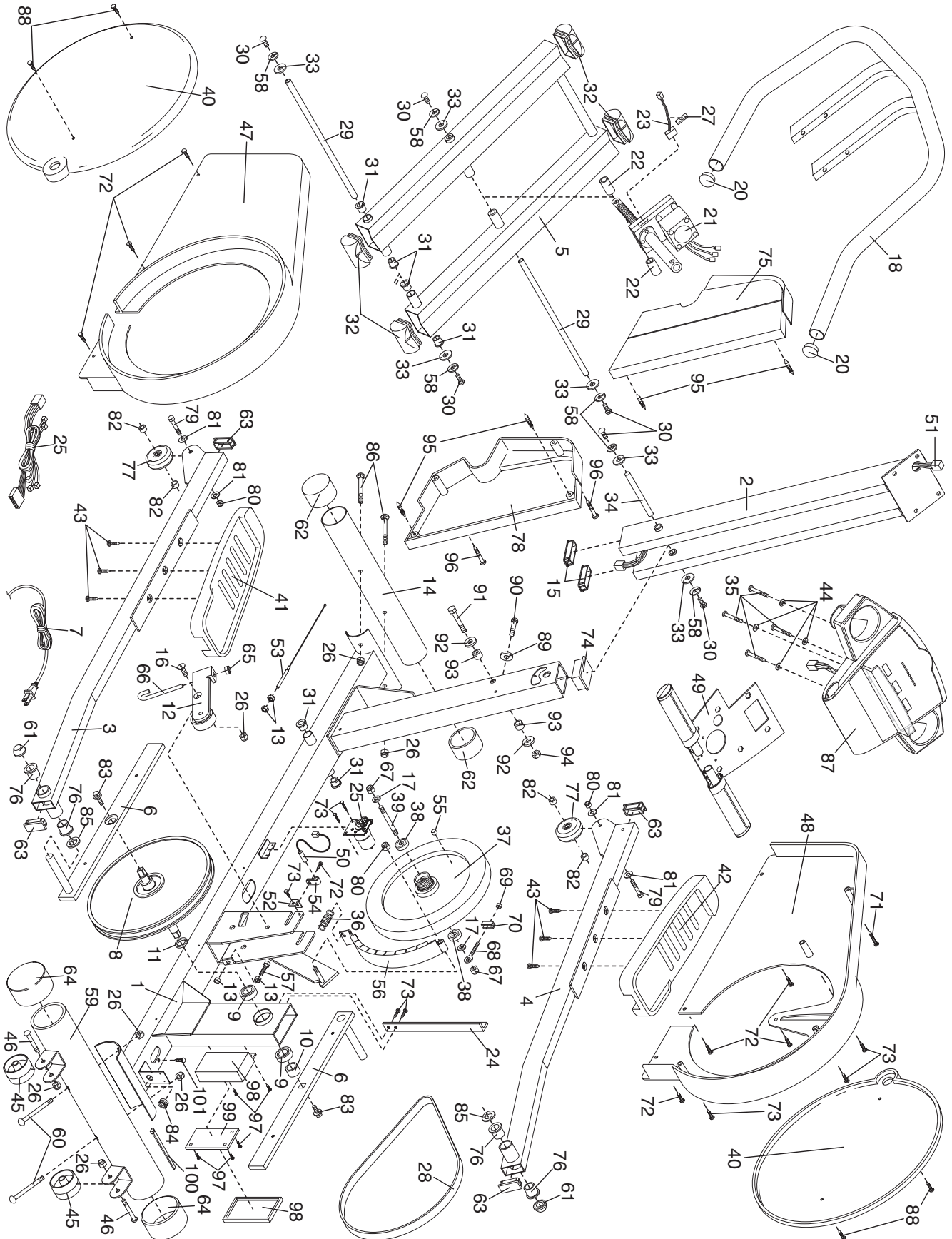

HOW TO ORDER REPLACEMENT PARTS

To order replacement parts, simply call our Customer Service Department toll-free at 1-888-825-2588, Monday through Friday, 6 a.m. until 6 p.m. Mountain Time (excluding holidays). To help us assist you, please be prepared to give the following information when calling:

- The MODEL NUMBER of the product (NTEL11990)
- The NAME of the product (NordicTrack® VGR970 elliptical crosstrainer)
- The SERIAL NUMBER of the product (see the front cover of this manual)
- The KEY NUMBER and DESCRIPTION of the part(s) (see page 22 of this manual).

LIMITED WARRANTY

WHAT IS COVERED—The entire NordicTrack® VGR970 elliptical crosstrainer ("Product") is warranted to be free of all defects in material and workmanship.

WHO IS COVERED—The original purchaser or any person receiving the Product as a gift from the original purchaser.

HOW LONG IS IT COVERED—ICON Health & Fitness, Inc. ("ICON"), warrants the product for two years after the date of purchase. Labor is covered for two years.

WHAT WE DO TO CORRECT COVERED DEFECTS—We will ship to you, without charge, any replacement part or component, providing the repairs are authorized by ICON first and are performed by an ICON trained and authorized service provider, or, at our option, we will replace the Product.

WHAT IS NOT COVERED—Any failures or damage caused by unauthorized service, misuse, accident, negligence, improper assembly or installation, alterations, modifications without our written authorization or by failure on your part to use, operate, and maintain as set out in your User's Manual ("Manual").

WHAT YOU MUST DO—Always retain proof of purchase, such as your bill of sale; store, operate, and maintain the Product as specified in the Manual; notify our Customer Service Department of any defect within 10 days after discovery of the defect; as instructed, return any defected part for replacement or, if necessary, the entire product, for repair.

USER'S MANUAL—It is VERY IMPORTANT THAT YOU READ THE MANUAL before operating the Product. Remember to do the periodic maintenance requirements specified in the Manual to assure proper operation and your continued satisfaction.

HOW TO GET PARTS AND SERVICE—Simply call our Customer Service Department at 1-888-825-2588 and tell them your name and address and the serial number of your Product. They will tell you how to get a part replaced, or if necessary, arrange for service where your Product is located or advise you how to ship the Product for service. Before shipping, always obtain a Return Authorization Number (RA No.) from our Customer Service Department; securely pack your Product (save the original shipping carton if possible); put the RA No. on the outside of the carton and insure the product. Include a letter explaining the product or problem and a copy of your proof of purchase if you believe the service is covered by warranty.

ICON is not responsible or liable for indirect, special or consequential damages arising out of or in connection with the use or performance of the product or damages with respect to any economic loss, loss of property, loss of revenues or profits, loss of enjoyment or use, costs of removal, installation or other consequential damages of whatsoever nature. Some states do not allow the exclusion or limitation of incidental or consequential damages. Accordingly, the above limitation may not apply to you.

The warranty extended hereunder is in lieu of any and all other warranties and any implied warranties of merchantability or fitness for a particular purpose is limited in its scope and duration to the terms set forth herein. Some states do not allow limitations on how long an implied warranty lasts. Accordingly, the above limitation may not apply to you.

No one is authorized to change, modify or extend the terms of this limited warranty. This warranty gives you specific legal rights and you may have other rights which vary from state to state.

ICON HEALTH & FITNESS, INC., 1500 S. 1000 W., LOGAN, UT 84321-9813