

MEGOHMMETER

# C.A 6549



ENGLISH

User's manual

 **CHAUVIN®  
ARNOUX**  
CHAUVIN ARNOUX GROUP

Thank you for purchasing a **C.A. 6549 megohmmeter**.

To obtain the best service from your instrument:

- **read** this user manual carefully,
- **comply with** the precautions for use.



WARNING, risk of DANGER! The operator must refer to this user's manual whenever this danger symbol appears.



Equipment protected by double insulation.



WARNING! Risk of electric shock. The voltage of the parts identified by this symbol may be  $\geq 120$  V<sub>DC</sub>. For safety reasons, this symbol is displayed when such a voltage is generated.



Earth.



The CE marking indicates conformity with European directives, in particular LVD and EMC.



The rubbish bin with a line through it indicates that, in the European Union, the product must undergo selective disposal in compliance with Directive WEEE 2002/96/EC. This equipment must not be treated as household waste.

#### Definition of measurement categories:

- Measurement category IV corresponds to measurements taken at the source of low-voltage installations. Example: power feeders, counters and protection devices.
- Measurement category III corresponds to measurements on building installations. Example: distribution panel, circuit-breakers, machines or fixed industrial devices.
- Measurement category II corresponds to measurements taken on circuits directly connected to low-voltage installations. Example: power supply to electro-domestic devices and portable tools.

## PRECAUTIONS FOR USE

This device is compliant with safety standard IEC 61010-2-030 and the leads are compliant with IEC 61010-031, for voltages up to 1000 V with respect to earth in category III.

Failure to observe the safety instructions may result in electric shock, fire, explosion, and destruction of the instrument and of the installations.

- The operator and/or the responsible authority must carefully read and clearly understand the various precautions to be taken in use. Sound knowledge and a keen awareness of electrical hazards are essential when using this instrument.
- If you use this instrument other than as specified, the protection it provides may be compromised, thereby endangering you.
- Do not use the instrument on networks of which the voltage or category exceeds those mentioned.
- Do not use the instrument if it seems to be damaged, incomplete, or poorly closed.
- Before each use, check the condition of the insulation on the leads, housing, and accessories. Any item of which the insulation is deteriorated (even partially) must be set aside for repair or scrapping.
- Use personal protection equipment systematically.
- Use only the accessories delivered with the instrument.
- Respect the value and type of the fuse to avoid damaging the instrument and cancelling the warranty.
- Set the switch to OFF when the instrument is not in use.
- The battery must be charged before metrological tests.
- All troubleshooting and metrological checks must be performed by competent and accredited personnel.

# CONTENTS

<b>1. PRESENTATION</b> .....	<b>4</b>
1.1. The megohmmeter .....	4
1.2. The accessories .....	4
<b>2. DESCRIPTION</b> .....	<b>5</b>
2.1. Housing .....	5
2.2. Keys .....	6
2.2. Display .....	6
<b>3. MEASUREMENT FUNCTIONS</b> .....	<b>8</b>
3.1. AC / DC voltage .....	8
3.2. Insulation measurement .....	8
3.3. Capacitance measurement .....	9
3.4. Residual current measurement .....	9
<b>4. SPECIAL FUNCTIONS</b> .....	<b>10</b>
4.1. MODE / PRINT key .....	10
4.2. DISPLAY / GRAPH key .....	13
4.3. ◀ / T° Key .....	19
4.4. ▼ / SMOOTH Key .....	20
4.5. SET-UP function (instrument configuration) .....	20
4.6. List of coded errors .....	24
<b>5. PROCEDURE</b> .....	<b>25</b>
5.1. Course of measurements .....	25
5.2. Step function mode (Adj. Step) .....	26
<b>6. MEMORY / RS 232</b> .....	<b>28</b>
6.1. RS 232 characteristics .....	28
6.2. Storing / recalling measurement results (MEM/MR KEY) .....	28
6.3. Printing measured values (PRINT key) .....	29
<b>7. SPECIFICATIONS</b> .....	<b>34</b>
7.1. Reference conditions .....	34
7.2. Characteristics per function .....	34
7.3. Power supply .....	37
7.4. Environmental conditions .....	37
7.5. Construction specifications .....	37
7.6. Compliance with international standards .....	38
7.7. Variations within domain of use .....	38
<b>8. MAINTENANCE</b> .....	<b>39</b>
8.1. Servicing .....	39
8.2. Metrological check .....	39
8.3. Repair .....	39
<b>9. WARRANTY</b> .....	<b>40</b>
<b>10. TO ORDER</b> .....	<b>41</b>
10.1. Accessories .....	41
10.2. Replacement parts .....	41

# 1. PRESENTATION

## 1.1. THE MEGOHMMETER

The C.A 6549 megohmmeter is a portable unit, fitted into a rugged construction site casing with cover, operating on battery or line power.

Its main functions are:

- automatic detection and measurement of voltage, frequency, input current,
- quantitative and qualitative insulation measurement:
  - measurement at 500, 1000, 2500, 5000 V<sub>DC</sub> or other test voltage between 40 and 5100 V<sub>DC</sub> (“adjustable voltage”),
  - measurement in voltage step mode (the applied voltage increases in steps),
  - automatic calculation of DAR/PI and DD (dielectric discharge index) quality ratios,
  - automatic calculation of measurement result referred to a reference temperature.
- automatic capacitance measurement,
- automatic measurement of residual current.

This megohmmeter helps to ensure the safety of electrical installations and equipment.

Its operation is controlled by microprocessor for the acquisition, processing, measurement display, storage and printing of results.

It offers a wide range of advantages such as:

- digital filtering of insulation measurements,
- automatic voltage measurement,
- threshold programming, to trigger alarms using audible beeps,
- the timer for measurement duration checks,
- protection of the device by fuse, with detection of defective fuses,
- operator safety by means of automatic discharge of the test voltage on the equipment tested,
- automatic power save mode of the device to save battery power,
- indication of battery charge condition,
- large graphic display with backlight capability,
- memory (128 kB), real time clock and serial interface,
- PC control of the device (using PC software, optional),
- printing in RS 232 or Centronics mode.

## 1.2. THE ACCESSORIES

### 1.2.1. MEASURING CABLES

The megohmmeter is delivered with 4 measuring cables as standard:

- 2 3m safety cables (red & black with rear pick up), with an HV plug for connection to the instrument and an HV alligator clip for connection to the item tested
- 2 blue cables (3 m and 0.3 m with rear pick up) to measure high insulation values (see § 5.1).

Optionally, you can order the same cables in lengths of 8 m and 15 m, and also simplified cables (the alligator clip is replaced by a 4 mm banana jack to which standard alligator clips or contact pins can be connected).

### 1.2.2. PC SOFTWARE (OPTIONAL)

This PC software is used to:

- download data stored in the instrument,
- print customised test protocols in accordance with user needs,
- create Excel™ spreadsheets,
- configure and control the unit via the RS 232,

The minimum recommended configuration is a PC with a 486DX100 processor.

### 1.2.3. SERIAL PRINTER (OPTIONAL)

This compact printer can be used to print measurement results, directly in the field.

### 1.2.4. SERIAL-PARALLEL ADAPTER (OPTIONAL)

The optional RS232/Centronics adapter converts the serial interface (RS232) into a parallel printer interface (Centronics), making it possible to print all measurements directly on A4-format office printers, without using a personal computer.

## 2. DESCRIPTION





### 2.1. HOUSING



①	3 4mm-dia. safety terminals identified as “+”, “G”, and “-”.
②	Access to the fuse that protects terminal “G”.
③	8-way rotary switch: <ul style="list-style-type: none"> <li>■ OFF switches instrument power off.</li> <li>■ 500V - 2TΩ insulation measurement at 500 V up to 2 TΩ.</li> <li>■ 1000V - 4TΩ insulation measurement at 1000 V up to 4 TΩ.</li> <li>■ 2500V - 10TΩ insulation measurement at 2500 V up to 10 TΩ.</li> <li>■ 5000V - 10TΩ insulation measurement at 5000 V up to 10 TΩ.</li> <li>■ Adjust. 50V...5000V insulation measurement with adjustable test voltage (from 40 V to 5100 V: 10 V steps from 40 to 1000 V and 100 V steps from 1000 to 5100 V).</li> <li>■ Adjust. STEP insulation measurement with voltage step function (the test voltage varies in steps).</li> <li>■ SET-UP adjustment of instrument configuration.</li> </ul>
④	1 yellow START / STOP key: beginning / end of measurement
⑤	8 elastomer keys each having a main function and a secondary function.
⑥	1 backlit graphic screen.
⑦	1 socket for connection to line power (direct operation on line power and/or battery charging).
⑧	1 RS 232 serial INTERFACE male connector (9 pins) for connection to a PC or printer.

## 2.2. KEYS

8 keys each having a main function and a secondary function:

<i>2nd</i>	Select the secondary function (indicated in yellow italics below each key).
<b>MODE</b> <i>PRINT</i>	<b>Primary function:</b> select the desired type of measurement, before an insulation measurement, or select the current range, during a measurement. <b>Secondary function:</b> enter the PRINT menu to print measurement results.
<b>DISPLAY</b> <i>GRAPH</i>	<b>Primary function:</b> browse through the various screens accessible before, during and after the measurement. <b>Secondary function:</b> display insulation resistance versus duration after a time-limited measurement.
 	<b>Primary function:</b> select a parameter one step to the right of the current cursor position (from the end of the line, the cursor jumps to the beginning of the line). <b>Secondary function:</b> activate/deactivate display backlight.
 <i>T°</i>	<b>Primary function:</b> deselect a selection or move the cursor one parameter to the left. <b>Secondary function:</b> enter the TEMPERATURE menu to refer the measurement to a specified temperature.
 <i>ALARM</i>	<b>Primary function:</b> move the cursor up or increment the selected parameter (flashing or indicated by the cursor). If the key is kept pressed, the rate of change of the parameters is increased. <b>Secondary function:</b> activate / deactivate the alarms programmed in the SET-UP menu , or move the cursor one page up in a long menu..
 <i>SMOOTH</i>	<b>Primary function:</b> move the cursor down or decrement the selected parameter (flashing or indicated by the cursor). If the key is kept pressed, the rate of change of the parameters is increased. <b>Secondary function:</b> enable / disable smoothing of the insulation resistance indication, or move the cursor one page down in a long menu.
<b>MEM</b> <i>MR</i>	<b>Primary function:</b> store measured values. <b>Secondary function:</b> recall stored data.

## 2.3. DISPLAY

### 2.3.1. GRAPHIC DISPLAY UNIT

The display unit is a graphic display unit with a resolution of 320 x 240 pixels. It has a built-in backlighting that can be activated or deactivated using the  key.

The various screens that are accessible are presented and explained throughout this manual. We explain below, however, the various symbols that may appear on the screen.

### 2.3.2. SYMBOLS

**REMOTE** Indicates that the instrument is controlled remotely via the interface.  
In this mode, all of the keys and the rotary switch are inactive, except for shutdown of the instrument (OFF position).

**COM** Indicates that the instrument is sending data to the printer via the interface.

**2nd** Indicates that the secondary function of a key will be used.

 Indicates that the “programmed time test” mode was selected before the measurement was started.

**DAR** Indicates that the “automatic calculation of Dielectric Absorption Ratio” mode was selected before the measurement was started.

**PI** Indicates that the “automatic calculation of Polarization Index” mode was selected before the measurement was started.

**DD** Indicates that the “automatic calculation of Dielectric Discharge Index” mode was selected before the measurement was started.

**SMOOTH** Indicates that smoothing of the insulation resistance indication is activated.

**ALARM** Indicates that the alarm is enabled. An audible alarm will be emitted if the value measured is below the limit value defined in the SET-UP menu.

 Indicates the battery charge condition (see § 8.1.1).



Voltage generated dangerous,  $U > 120V_{DC}$ .



External voltage present,  $U > 25 V_{RMS}$

## 3. MEASUREMENT FUNCTIONS

### 3.1. AC / DC VOLTAGE

Turning the switch to an insulation position (position other than OFF or SET-UP) sets the instrument to automatic AC / DC voltage measurement. The voltage between the input terminals is measured at all times and indicated as RMS value on the display unit: Input Voltage. Switching between AC and DC mode is automatic.

When switch is turned, the frequency and the residual DC current between the terminals of the instrument are also measured. (The residual current is measured in order to evaluate its impact on the insulation measurement to come).

FIXED VOLTAGE	
<b>2500 V</b>	
Input voltage	⚠ 230 V AC
Frequency	50.0 Hz
Input current	24.6 nA
Date: 24.06.2008	Time: 15:31

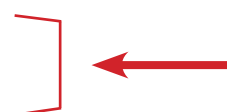

The insulation measurements cannot be started if there is an excessively high external voltage on the terminals, in which case the ⚠ symbol is displayed next to the measured external voltage (see § 3.2).

### 3.2. INSULATION MEASUREMENT

- When the switch is turned to an insulation position, one of the following displays appears:

#### Case 1

You select an insulation measurement with a fixed / standard test voltage, in manual mode.

Positions:

**500V - 2T $\Omega$**

**1000V - 4T $\Omega$**

**2500V - 10T $\Omega$**

**5000V - 10T $\Omega$**

FIXED VOLTAGE	
<b>2500 V</b>	
Input voltage	⚠ 230 V AC
Frequency	50.0 Hz
Input current	24.6 nA
Date: 24.06.2008	Time: 15:31

#### Case 2

You select an insulation measurement with a test voltage other than those proposed as standard.

Position:

**Adjust. 50V...5000V**

You can choose from the 3 "adjusted" voltages predefined in SET-UP using the ▲ and ▼ keys, or define another voltage by selecting it with the ► key and adjusting it with the ▲ and ▼ keys.

ADJUSTABLE VOLTAGE 1	
<b>2300 V</b>	
Input voltage	20 V AC
Frequency	50.0 Hz
Input current	24.6 nA
Date: 24.06.2008	Time: 15:31



### Case 3

You select an insulation measurement with a test voltage that varies in steps: this is the “step function” mode.

Position:

#### Adjust. Step

You can choose among the three step functions (▲ and ▼ keys) you defined earlier in SET-UP.

STEP FUNCTION 1	
Min: 2300 V	Max: 3900 V
	
Test Run Time 08:38:30	
Input voltage	1 V AC
Frequency	50.0 Hz
Input current	24.6 nA
Date: 24.06.2008	Time: 15:31

#### ■ Pressing the START/STOP key immediately triggers the measurement.

An audible beep is emitted every 10 seconds to indicate that a measurement is in progress.

**Important remark:** These insulation measurements cannot be started if there is an excessively high external voltage on the terminals.

- If, when the START key is pressed, the external voltage on the terminals of the instrument is greater than the value  $U_{peak}$  defined below, the insulation measurement is not triggered and an audible alarm is emitted; the instrument then returns to automatic voltage measurement.

$$U_{peak} \geq 2 \times dISt \times U_n$$

where -  $U_{peak}$ : external voltage, peak or DC, on the terminals of the instrument.  
-  $dISt$ : coefficient that can be adjusted in SET-UP - 3% (default value), 10% or 20%.  
-  $U_n$ : test voltage selected for the insulation measurement.

- Similarly, if during the insulation measurements, an external voltage greater than the value  $U_{peak}$  defined below is detected, the measurement is stopped and the symbol  $\triangle$  appears next to the value of the external voltage measured.

$$U_{peak} \geq (dISt + 1.1) \times U_n$$

where -  $U_{peak}$ : external voltage, peak or DC, on the terminals of the instrument.  
-  $dISt$ : coefficient that can be adjusted in SET-UP - 3% (default value), 10% or 20%.  
-  $U_n$ : test voltage selected for the insulation measurement.

**Note:** Adjust the  $dISt$  factor to optimize the measurement build-up time. If there is no disturbance voltage,  $dISt$  can be set to its minimum value to obtain the shortest possible measurement build-up time.

If there is a large disturbance voltage,  $dISt$  can be increased so that the measurement can be started and will not be interrupted.

#### ■ Pressing the START/STOP key again stops the measurement.

If a “programmed time test” mode (Timed Run or Timed Run + DD) was selected as measurement mode, the measurement is stopped (without action on the START/STOP button) at the end of this time.

Similarly, if the DAR or PI mode is selected as measurement mode, the measurement is stopped after the time needed to calculate them.

**Note:** When measuring resistances smaller than the resistance range indicated for the selected test voltage, the test voltage is automatically reduced. So 10 k $\Omega$  can be measured as the minimum resistance regardless of the selected test voltage..

## 3.3. CAPACITANCE MEASUREMENT

The capacitance measurement is performed automatically during the insulation measurement, and is displayed after the measurement stops and the circuit has been discharged.

## 3.4. RESIDUAL CURRENT MEASUREMENT

The residual current circulating in the installation is measured automatically upon connection to the installation, then before and after the insulation measurement.

## 4. SPECIAL FUNCTIONS

### 4.1. MODE / PRINT KEY

#### 4.1.1. PRIMARY FUNCTION BEFORE THE MEASUREMENT

The primary function of the MODE key is very important: it is used before the measurement to define the course of the measurement.

This key is inactive in the “Adjust. Step” and SET-UP positions.

Pressing the MODE key gives access to the list of possible measurement modes. Select the mode using the ▲ and/or ▼ keys.

To validate the mode selected, press the MODE key again.

The various measurement modes are as follows:

#### ■ MANUAL STOP:

This is the conventional quantitative insulation measurement mode. The measurement is started by pressing START / STOP and stopped by pressing START / STOP again.

The user determines the duration, which is indicated by the measurement duration chronometer.

MODE		
Total Run Time	---	
▶ Manual Stop		
Manual Stop + DD	Duration	Sample
	(h:m)	(m:s)
Timed Run	02:30	00:10
Timed Run + DD		
DAR (s/s)	30/60	
PI (m/m)	1.0/10	

#### ■ MANUAL STOP + DD:

The measurement is started by pressing START/STOP and stopped by pressing START/STOP again.

One minute after the end of the measurement, the instrument calculates and display the DD term. The time remaining during this minute is displayed.

MODE		
Total Run Time	---	
Manual Stop		
▶ Manual Stop + DD		
	Duration	Sample
	(h:m)	(m:s)
Timed Run	02:30	00:10
Timed Run + DD		
DAR (s/s)	30/60	
PI (m/m)	1.0/10	

#### ■ TIMED RUN:

(Timed run test)

This mode is used to perform a measurement for a duration defined in advance, with a predetermined number of measurement samples: the measurement is started by pressing START / STOP and stops automatically after the time programmed by the user.

This duration (Duration) and the time interval between samples (Sample) can be modified using the ▲, ▼, ► and ◀ keys when the Timed Run mode is selected.

When the measurement is started, the chronometer counts down the time remaining. When this time (Remaining Time) is zero, the measurement is stopped.

MODE		
Total Run Time	02:30:00	
Manual Stop		
Manual Stop + DD		
	Duration	Sample
	(h:m)	(m:s)
▶ Timed Run	02:30	00:10
Timed Run + DD		
DAR (s/s)	30/60	
PI (m/m)	1.0/10	

During the execution of a timed run test, the intermediate samples are automatically stored: they are used to plot insulation resistance vs. time. This curve can be displayed after the measurement by pressing the GRAPH key, as long as no new measurement has been started.

The samples are automatically stored with the final value of the resistance, if it is stored.

During the measurement, if **the position of the rotary switch is changed**, or **the STOP key is pressed**, the measurement is stopped.

■ **TIMED RUN + DD:**

This mode is identical to the previous one except that 1 minute after the end of the measurement the instrument calculates and displays the DD term.  
The measurement duration is therefore: duration of timed run + 1 minute.

The insulation resistance vs. time curve can be displayed after the measurement by pressing *GRAPH*, as long as no new measurement has been started.

MODE		
Total Run Time	02:30:00	
Manual Stop		
Manual Stop + DD		
	Duration	Sample
	(h:m)	(m:s)
Timed Run	02:30	00:10
▶ Timed Run + DD		
DAR (s/s)	30/60	
PI (m/m)	1.0/10	

■ **DAR:**

The measurement is started by pressing START / STOP and stops automatically when the DAR ratio has been calculated, i.e. after 1 minute, the time for measuring the second insulation resistance value needed for the calculation (the sample time can be modified with the ▲, ▼, ► and ◀ keys).

MODE		
Total Run Time	00:01:00	
Manual Stop		
Manual Stop + DD		
	Duration	Sample
	(h:m)	(m:s)
Timed Run	02:30	00:10
Timed Run + DD		
▶ DAR (s/s)	30/60	
PI (m/m)	1.0/10	

■ **PI:**

The measurement is started by pressing START / STOP and stops automatically when the PI ratio has been calculated, i.e. after 10 minutes, the time for measuring the second insulation resistance value needed for the calculation (the sample times can be modified with the ▲, ▼, ► and ◀ keys).

MODE		
Total Run Time	00:10:00	
Manual Stop		
Manual Stop + DD		
	Duration	Sample
	(h:m)	(m:s)
Timed Run	02:30	00:10
Timed Run + DD		
DAR (s/s)	30/60	
▶ PI (m/m)	1.0/10	

**Remark:** in this mode, the DAR ratio will also be calculated automatically if the times needed to calculate it are less than the second time needed to calculate the PI ratio.

**Important remarks:**

What is the DD (Dielectric Discharge index)?

In the case of multilayer insulation, if one of the layers is defective but the resistance of all the others is high, neither the quantitative insulation measurement nor the calculation of the PI and DAR quality ratios will reveal the problem.

This makes it judicious to perform a dielectric discharge test, from which the DD term can be calculated. This test measures the dielectric absorption of heterogeneous or multilayer insulation and disregards parallel-surface leakage currents.

It involves applying a test voltage for long enough to electrically “charge” the insulation to be measured (typically, a voltage of 500 V is applied for 30 minutes).

At the end of the measurement, the instrument causes a rapid discharge, during which the capacitance of the insulation is measured; 1 minute later, the residual current circulating in the insulation is measured.

The DD term is then calculated as follows:

$$DD = \text{current measured after 1 minute (mA)} / [\text{test voltage (V)} \times \text{measured capacitance (F)}]$$

The insulation quality rating as a function of the value found is as follows:

Value of DD	Quality of insulation
7 < DD	Very poor
4 < DD < 7	Poor
2 < DD < 4	Borderline
DD < 2	Good

**Note:** The dielectric discharge test is especially well suited to insulation measurements on rotating machines, and, in general, to insulation measurements on heterogeneous or multilayer insulations containing organic materials.

*What are the DAR (Dielectric Absorption Ratio) and the PI (Polarization Index)?*

It is useful to calculate insulation quality ratios in addition to the quantitative insulation resistance value, because they can be used to eliminate the influence of certain parameters likely to invalidate the “absolute” insulation measurement.

The most important of these parameters are:

- temperature and relative humidity, with which insulation resistance varies according to a quasi-exponential law.
- the disturbance currents (capacitive charging current, dielectric absorption current) created by the application of the test voltage. Even though they gradually vanish, they perturb the measurement at the start, for a length of time that depends on whether the insulation is in good condition or degraded.

These ratios complete the “absolute” insulation value, and reliably reflect whether the insulation is in good or poor condition.

In addition, changes in these ratios over time can be observed and used for predictive maintenance, e.g. to monitor the ageing of the insulation of a population of rotating machines.

The DAR and PI ratios are calculated as follows:

**PI = R 10 min / R 1 min** (2 values to be noted during a 10-min measurement.)

**DAR = R 1 min / R 30 sec** (2 values to be noted during a 1-min measurement.)

**Remark:** Note that the times of 1 & 10 min for the calculation of PI and 30 & 60 seconds for the calculation of DAR are those currently used and programmed as defaults in the instrument.

They can however be modified in SET-UP to adapt to a possible change in a standard or to the needs of a specific application.

A capacitance in parallel to the insulation resistance extends the settling times of the measurements. This can affect or even inhibit the measurement of DAR or PI (depending on the time set for recording the first resistance value). The following table shows typical values for the capacitance in parallel to the insulation resistance at which a successful DAR or PI measurement is still possible (at the default time for recording the first resistance value).

	100 kΩ	1 MΩ	10 MΩ	100 MΩ	1 GΩ	10 GΩ	100 GΩ
50 V	40 μF	40 μF	20 μF	10 μF	1 μF	0 μF	0 μF
100 V	40 μF	40 μF	20 μF	10 μF	1 μF	0 μF	0 μF
500 V	20 μF	20 μF	10 μF	5 μF	2 μF	1 μF	1 μF
1000 V	5 μF	5 μF	5 μF	2 μF	2 μF	1 μF	1 μF
2500 V	2 μF	2 μF	2 μF	1 μF	0.5 μF	0 μF	0 μF
5000 V	1 μF	1 μF	1 μF	0,5 μF	0.5 μF	0 μF	0 μF

Interpretation of the results:

DAR	PI	Condition of insulation
< 1.25	< 1	Poor or even dangerous
	< 2	
< 1.6	< 4	Good
> 1.6	> 4	Excellent

**4.1.2. PRIMARY FUNCTION DURING THE MEASUREMENT**

During the measurement, the first function of the MODE key is to select the Range of the current: automatic (default) or fixed.

Display range	< 10 MΩ	> 10 MΩ	GΩ	TΩ
Number	3	2	1	1

Press the MODE key, then the ► key to select the Range, then the ▲ or ▼ key to modify it.

The choice of Range of current is validated by pressing the MODE key again. The choice remains active until the switch is turned.

In the Adj. Volt. position, the MODE key can be used to modify the voltage value during the measurement.

### 4.1.3. SECONDARY FUNCTION

The PRINT secondary function is described in § 6.3 (Printing of measured values).

## 4.2. DISPLAY / GRAPH KEY

### 4.2.1. PRIMARY FUNCTION DISPLAY

This key is used to browse through the various accessible screens containing all information available before, during or after the measurement.

The screens vary depending on the mode selected before the measurement is started.

#### ■ MANUAL STOP mode

Before the measurement

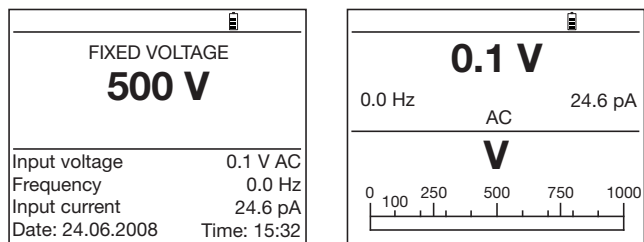

Available information:

First screen	Press on DISPLAY
Selected test voltage Input voltage Frequency Input current (DC only) Date, time	Input voltage Frequency Input current (DC only) Voltage bargraph

During the measurement

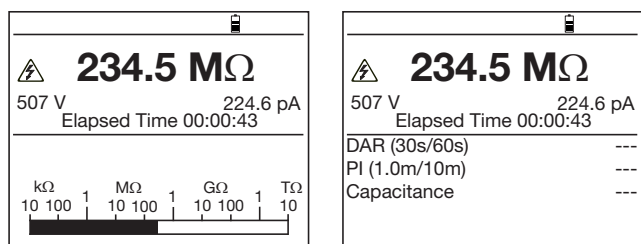

Available information:

First screen	Press on DISPLAY
Insulation resistance Measured voltage Measured current Elapsed test duration Resistance bargraph	Insulation resistance Measured voltage Measured current Elapsed test duration DAR, PI, capacitance

After the measurement

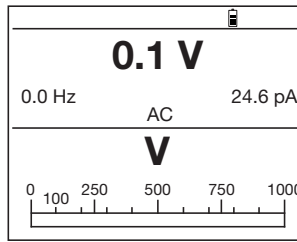
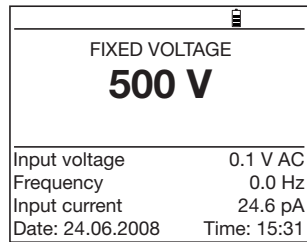
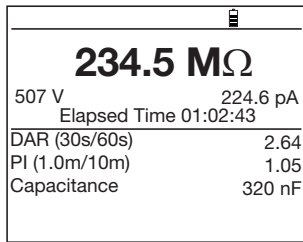

Available information:

First screen	Press on DISPLAY	2 <sup>nd</sup> press on DISPLAY
Insulation resistance Measured voltage Measured current Elapsed test duration DAR, PI, capacitance	Selected test voltage Input voltage Frequency Input current (DC only) Date, time	Input voltage Frequency Input current (DC only) Voltage bargraph

■ MANUAL STOP + DD mode

Before the measurement

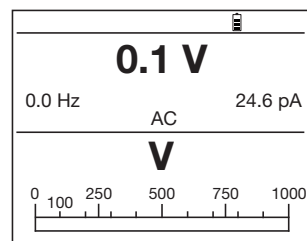
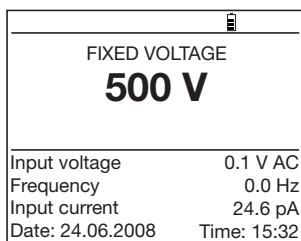

Available information:

First screen	Press on DISPLAY
Selected test voltage Input voltage Frequency Input current (DC only) Date, time	Input voltage Frequency Input current (DC only) Voltage bargraph

During the measurement

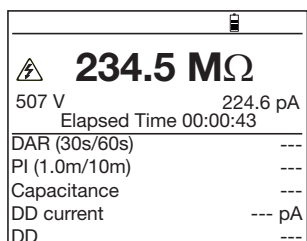
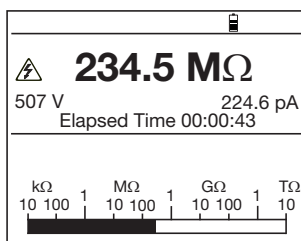

Available information:

First screen	Press on DISPLAY
Insulation resistance Measured voltage Measured current Elapsed test duration Resistance bargraph	Insulation resistance Measured voltage Measured current Elapsed test duration DAR, PI, capacitance Current (for the calculation of DD) DD

After the measurement

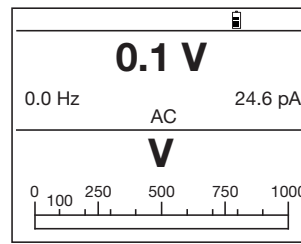
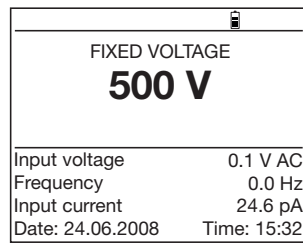
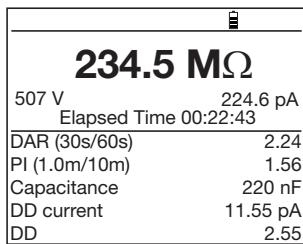

Available information:

First screen	Press on DISPLAY	2 <sup>nd</sup> press on DISPLAY
Insulation resistance Measured voltage Measured current Elapsed test duration DAR, PI, capacitance Current (for the calculation of DD) DD	Selected test voltage Input voltage Frequency Input current (DC only) Date, time	Input voltage Frequency Input current (DC only) Voltage bargraph

■ TIMED RUN mode

Before the measurement

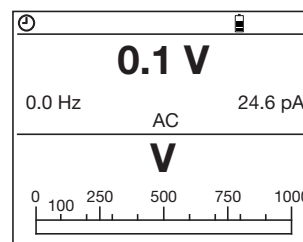
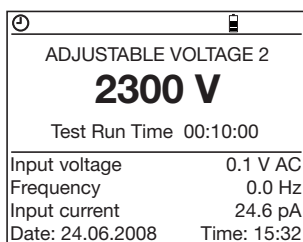

Available information:

First screen	Press on DISPLAY
Selected test voltage Programmed test duration Input voltage Frequency Input current (DC only) Date, time	Input voltage Frequency Input current (DC only) Voltage bargraph

During the measurement

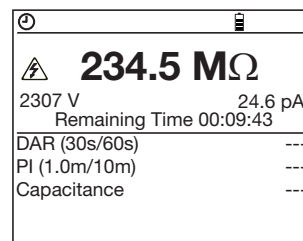
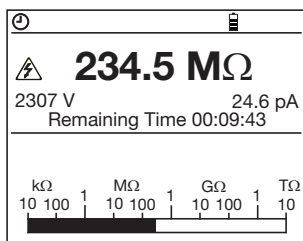

Available information:

First screen	Press on DISPLAY
Insulation resistance Measured voltage Measured current Remaining test duration Resistance bargraph	Insulation resistance Measured voltage Measured current Remaining test duration DAR, PI, capacitance

After the measurement

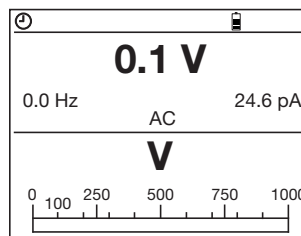
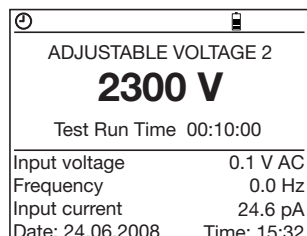
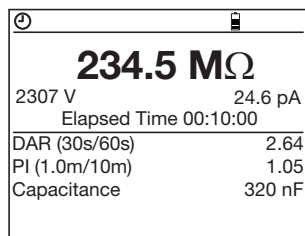

Available information:

First screen	Press on DISPLAY	2 <sup>nd</sup> press on DISPLAY
Insulation resistance Measured voltage Measured current Test duration DAR, PI, capacitance	Selected test voltage Programmed test duration Input voltage Frequency Input current (DC only) Date, time	Input voltage Frequency Input current (DC only) Voltage bargraph

■ **TIMED RUN + DD mode**

Before the measurement

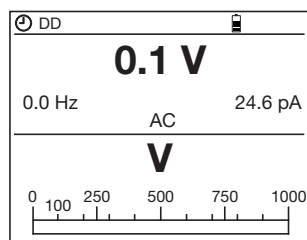
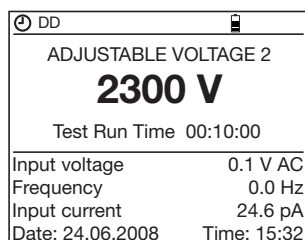

Available information:

First screen	Press on DISPLAY
Selected test voltage Programmed test duration Input voltage Frequency Input current (DC only) Date, time	Input voltage Frequency Input current (DC only) Voltage bargraph



During the measurement

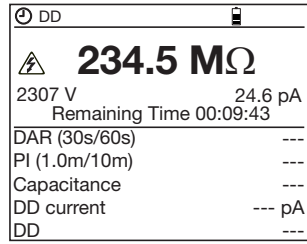
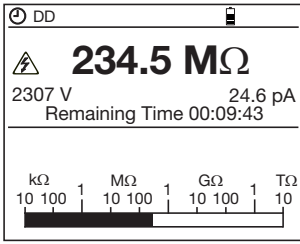

Available information:

First screen	Press on DISPLAY
Insulation resistance Measured voltage Measured current Remaining test duration Resistance bargraph	Insulation resistance Measured voltage Measured current Remaining test duration DAR, PI, capacitance Current (for the calculation of DD) DD

After the measurement

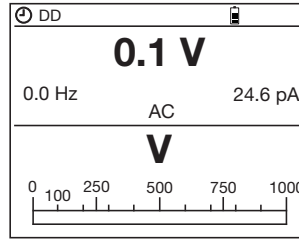
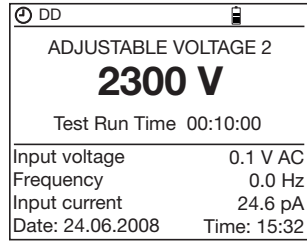
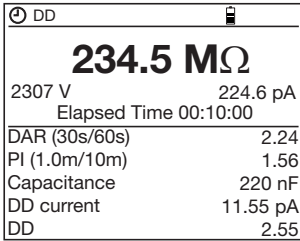

Available information:

First screen	Press on DISPLAY	2 <sup>nd</sup> press on DISPLAY
Insulation resistance Measured voltage Measured current Test duration DAR, PI, capacitance Current (for the calculation of DD) DD	Selected test voltage Programmed test duration Input voltage Frequency Input current (DC only) Date, time	Input voltage Frequency Input current (DC only) Voltage bargraph

■ DAR mode

Before the measurement

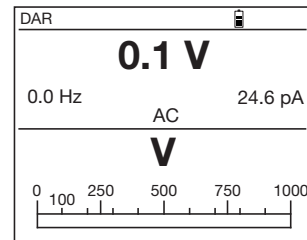
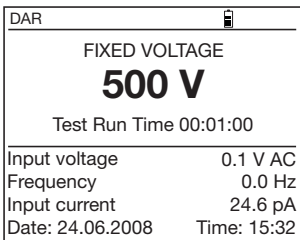

Available information:

First screen	Press on DISPLAY
Selected test voltage Programmed test duration Input voltage Frequency Input current (DC only) Date, time	Input voltage Frequency Input current (DC only) Voltage bargraph

During the measurement

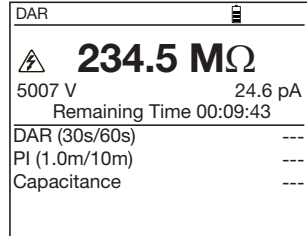
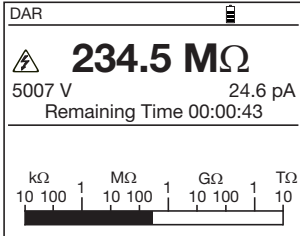

Available information:

First screen	Press on DISPLAY
Insulation resistance Measured voltage Measured current Remaining test duration Resistance bargraph	Insulation resistance Measured voltage Measured current Remaining test duration DAR, PI, capacitance

After the measurement

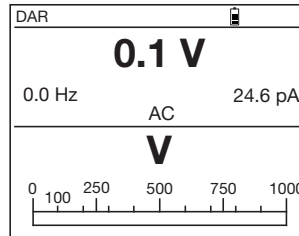
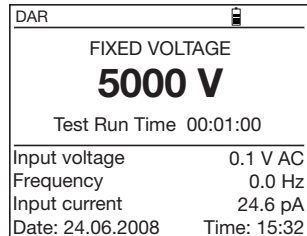
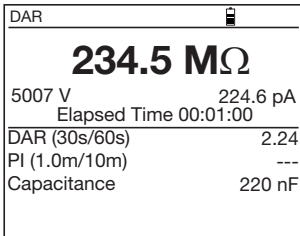

Available information:

First screen	Press on DISPLAY	2 <sup>nd</sup> press on DISPLAY
Insulation resistance Measured voltage Measured current Elapsed test duration DAR, PI, capacitance	Selected test voltage Programmed test duration Input voltage Frequency Input current (DC only) Date, time	Input voltage Frequency Input current (DC only) Voltage bargraph

■ PI mode

Same as DAR mode except:

- PI instead of DAR at the top left of the display unit
- Remaining Time = 10 min
- After the measurement: display of DAR and PI.

### 4.2.2. GRAPH SECONDARY FUNCTION

This function is used to display the insulation resistance versus measurement time curve after a time-limited measurement (Timed Run or Timed Run + DD).

This curve is plotted from the samples recorded during the measurement. The ▲, ▼, ► and ◀ keys can be used to move along the curve to display the exact values of each sample.

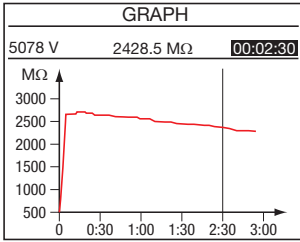

### 4.3. ◀ / T° KEY

The T° secondary function can be used in two ways. One is to assign a Probe Temperature to an insulation resistance measurement, the other to refer the resistance to a temperature different from the measurement temperature.

This makes it possible to observe the insulation resistance over time and judge its evolution under comparable temperature conditions. This is because insulation resistance varies with temperature according to a quasi-exponential law.

As part of a maintenance program covering a population of motors, for example, it is important to perform periodic measurements under similar temperature conditions. Otherwise, the results obtained must be corrected to refer them to a fixed reference temperature. This function can do this.

**Attention:**

- The T° function is not available in the Adjustable Step position.
- If the result of the insulation resistance measurement is out of range (“<” or “>”) no temperature corrected resistance can be calculated.

**Procedure:**

- You have just made a measurement and have not yet stored it. Make sure that the result is not out of range, then enter the T° mode by pressing 2nd then T°.

TEMPERATURE	
Probe Temperature	23°C
Resistance Correction	On
Rc Reference Temperature	40°C
ΔT for R/2	10°C
<hr/>	
R measured	1.002 MΩ
Rc at 40°C	309 kΩ

- Enter the Probe Temperature at which you made the measurement (by default, the instrument proposes the value set in SET-UP).
- If you want to know the resistance of the probe at another temperature, set “Resistance Correction” to “On” to perform the calculation.
- The calculation is performed immediately and the result is displayed: Rc. This indicates what the measurement result would have been at the reference temperature. Use the ▲, ▼, ► and ◀ keys to modify the temperatures.
- To assign this calculation (or only the Probe Temperature) to the measurement result, press 2nd + T° again (OK is then displayed).

**Remarks:**

- During the procedure, pressing the DISPLAY key or turning the switch cancels the modifications.
- If the coefficient ΔT used for the calculation is not known, the instrument can calculate it in advance, using at least 3 stored measurements made at different temperatures (see § 4.5.3)
- Detail concerning the calculation performed:

The insulation resistance varies with the measurement temperature.

This dependence can be approximated by an exponential function:

$$R_c = K T \cdot R_T$$

where R<sub>c</sub>: insulation resistance at reference temperature.  
 R<sub>T</sub>: insulation resistance measured at T°C (Probe Temperature).  
 K<sub>T</sub>: coefficient at T°C defined as follows:

$$K_T = (1/2)^{((R_c \text{ Reference Temperature} - T) / \Delta T)}$$

with T: temperature at the time of the measurement (Probe Temperature)  
 ΔT: temperature difference at which the insulation resistance is halved.

R<sub>c</sub> Reference Temperature: temperature for which the temperature corrected resistance (R<sub>c</sub>) is calculated.

#### 4.4. ▼ / SMOOTH KEY

The SMOOTH secondary function activates / deactivates an insulation measurement digital filter. It affects only the display (which is smoothed), not the measurements.

This function is useful if the insulation values displayed are very unstable.

The filter is calculated as follows:

$$RSMOOTH = RSMOOTH + (R - RSMOOTH) / N$$

Since N is set to 20, the time constant of this filter is approximately 20 seconds.

#### 4.5. SET-UP FUNCTION (INSTRUMENT CONFIGURATION)

This function, located on the rotary switch, can be used to change the configuration of the instrument by accessing directly the parameters to be modified.

Turning the rotary switch to SET-UP gives you access to the menu of all modifiable parameters. Select the parameter to be modified and its value using the ▲, ▼, ► and ◀ keys.

##### 4.5.1. SET-UP MENU

SET-UP	
Instr.Nr. 700016	SW Version 1.8
▣ Display Contrast	80
Alarm Settings	
Adjust Voltage 1	50 V
Adjust Voltage 2	100 V
Adjust Voltage 3	250 V
Timed Run (h:m)	0:10
Sample Time (m:s)	0:10
DAR (s/s)	30/60

SET-UP	
Instr.Nr. 700016	SW Version 1.8
PI (m/m)	1.0/10
Set Step Function 1	
Set Step Function 2	
Set Step Function 3	
Temperature Unit	Celsius
Default Probe Temperature	23°C
Rc Reference Temperature	40°C
▣ ΔT for R/2	10°C

SET-UP	
Instr.Nr. 700016	SW Version 1.8
Calculate ΔT from Memory	
Maximum Output Voltage	5100V
Set Default Parameter	
Clear Memory	
V Disturbance / V Output	3%
Buzzer	On
Power Down	On
▣ BaudRate	9600 / RS 232

SET-UP	
Instr.Nr. 700016	SW Version 1.8
Clear Memory	
V Disturbance / V Output	3%
Buzzer	On
Power Down	On
BaudRate	9600 / RS 232
Units	Europe
Date (d.m.y)	27.04.2009
▣ Time (h:m)	10:21

##### Description of each instrument configuration parameter:

- **Display Contrast:** modification of display unit contrast.

Default value	Range
80	0 ... 255 Attention: the display unit is no longer legible above 130.

- **Alarm Settings:** programming of measurement threshold values below which an audible alarm is triggered.

	Default value	Range
500 V	< 500 kΩ	30 kΩ ... 2 TΩ
1000 V	< 1.0 MΩ	100 kΩ ... 4 TΩ
2500 V	< 2.5 MΩ	300 kΩ ... 10 TΩ
5000 V	< 5 MΩ	300 kΩ ... 10 TΩ
Adj. Voltage 1	< 50 kΩ	10 kΩ ... 10 TΩ
Adj. Voltage 2	< 100 kΩ	10 kΩ ... 10 TΩ
Adj. Voltage 3	< 250 kΩ	10 kΩ ... 10 TΩ

**Note:** to return to the SET-UP menu, press the DISPLAY key.

- **Adjustable Voltage 1, 2, 3:** adjustable voltage: 3 different values can be predefined.

	Default value	Range
Adjustable Voltage 1	50 V	40 ... 5100 V
Adjustable Voltage 2	100 V	in steps of 10 V from 40 to 1000 V
Adjustable Voltage 3	250 V	in steps of 100 V from 1000 to 5100 V.

- **Timed Run (h:m):** duration of test in "Timed run" mode.

Default value	Range
00: 10 (h:m)	00: 01 ... 49: 59 (h:m)

- **Sample Time (m:s):** time interval between samples recorded in Timed Run mode for plotting R(t).

Default value	Range
00: 10 (m:s)	00: 05 ... 59: 59 (m:s) The limit depends on the duration set for the Timed Run.

- **DAR (s/s):** 1<sup>ST</sup> and 2<sup>ND</sup> times for the DAR calculation.

Default value	Range
30 / 60 (s/s)	10 ... 90 / 15 ... 180 (s/s) 5-second steps

- **PI (m/m):** 1<sup>ST</sup> et 2<sup>ND</sup> times for the PI calculation.

Default value	Range
01 / 10 (m/m)	0.5 ... 30 (0.5-, then 1-min steps) /1 ... 90 (0.5-, then 1-, then 5-min steps)

- **Set Step Function 1, 2, 3:** for each predefined step function, definition of the various voltages, of the duration of each step, and of the interval for the recording of samples. To skip a step, set the duration or the voltage to "---".

		Default value		Range	
		Voltage	Duration (h:m)	Voltage	Duration (h:m)
Step Function 1	Step 1	50 V	00: 01	40 ... 5100 V in 10-V then 100-V steps	00: 09 ... 09: 59
	Step 2	100 V	00: 01		00: 09 ... 09: 59
	Step 3	150 V	00: 01		00: 09 ... 09: 59
	Step 4	200 V	00: 01		00: 09 ... 09: 59
	Step 5	250 V	00: 01		00: 09 ... 09: 59
	sample time		00: 10 (m:s)		see note (00: 05...59: 59)
The limit depends on the duration set for the Timed Run.					
Step Function 2	Step 1	100 V	00: 01	40 ... 5100 V in 10-V then 100-V steps	00: 09 ... 09: 59
	Step 2	300 V	00: 01		00: 09 ... 09: 59
	Step 3	500 V	00: 01		00: 09 ... 09: 59
	Step 4	700 V	00: 01		00: 09 ... 09: 59
	Step 5	900 V	00: 01		00: 09 ... 09: 59
	sample time		00: 10 (m:s)		see note (00: 05...59: 59)
The limit depends on the duration set for the Timed Run.					
Step Function 3	Step 1	1000 V	00: 01	40 ... 5100 V in 10-V then 100-V steps	00: 09 ... 09: 59
	Step 2	2000 V	00: 01		00: 09 ... 09: 59
	Step 3	3000 V	00: 01		00: 09 ... 09: 59
	Step 4	4000 V	00: 01		00: 09 ... 09: 59
	Step 5	5000 V	00: 01		00: 09 ... 09: 59
	sample time		00: 10 (m:s)		see note (00: 05...59: 59)
The limit depends on the duration set for the Timed Run.					

**Note:** the minimum sample time depends on the total duration of the test (Total Run Time). It is equal to Sample Time (seconds) = (h+1)\*5 where h= hours of the Total Run Time.

- **Temperature Unit:** selection of temperature unit.

Default value	Range
°C	°C or °F

- **Default Probe Temperature:** measurement temperature.

Default value	Range
23 °C	-15°C ... +75°C

- **Rc Reference Temperature:** reference temperature to which the measurement result must be referred.

Default value	Range
40 °C	-15°C ... +75°C

- **ΔT for R/2:** estimated ΔT to obtain an insulation resistance / 2.

Default value	Range
10 °C	-15°C ... +75°C

- **Calculate ΔT from Memory:** used to calculate ΔT from 3 stored measurements made using the same probe at different temperatures (see § 4.5.3).

- **Maximum Output Voltage:** imposes maximum/locking of test voltage.

Default value	Range
5100 V	40 ... 5100 V

- **Set Default Parameter:** default configuration: reinitializes the instrument with the default values of all parameters.

- **Clear Memory:** can be used to partially or completely erase stored data (see § 4.5.2).

- **V Disturbance / V Output = dISt factor** (see § 3.2 - Important remark).

Default value	Range
3%	3, 10 or 20 %

- **Buzzer:** enabling / disabling of buzzer (keys, measurements, alarms).

Default value	Range
On	On or Off

- **Power Down:** automatic power save mode of the instrument after 1 min if no key is activated.

Default value	Range
Off	On or Off

- **Baud Rate:** RS 232 communication format and rate (see § 6.1)

Default value	Range
9600 / RS 232	300 ... 9600 / RS 232 or --- / Parallel

- **Units:** defines in which style the Date is displayed.

Default value	Range
Europe	Europe or USA

- **Date (d.m.y):** current date or setting of date.

Europe	dd.mm.yyyy
USA	mm.dd.yyyy

- **Time (h:m):** current time or setting of time.

#### 4.5.2. MEMORY ERASURE

In SET-UP, select **Clear memory**.

- To erase the content of one or more specific OBJ: TEST numbers
  - Select **Select Data Sets to Clear** by pressing ►.
  - Then each stored measurement to be erased using ▲, ▼, ► or ◀.
  - Validate by pressing DISPLAY. The operation is confirmed or cancelled by pressing ►.

SET-UP
Clear Memory :
<input checked="" type="checkbox"/> Select Data Sets to Clear
Clear All

SET-UP			
Clear Memory :			
Obj. Test	Date	Time	Fct.
47 99	15.12.2008	07:04	625V
<b>13 59</b>	07.12.2008	18:39	3800V⊙
<b>13 58</b>	24.11.2008	15:04	50V⊙
<b>02 03</b>	31.08.2008	15:47	2150V
<input checked="" type="checkbox"/> <b>02 02</b>	29.06.2008	16:56	975V
02 01	30.04.2008	08:43	5000V⊙
01 02	16.03.2008	09:07	⌂ ⊙

SET-UP
<b>! WARNING !</b>
All selected data sets will be cleared !
<input checked="" type="checkbox"/> O.K.
CANCEL

- To erase the entire memory
  - Select **Clear All** by pressing ►.
  - The operation is confirmed or cancelled by pressing ►.

SET-UP
Clear Memory :
Select Data Sets to Clear
<input checked="" type="checkbox"/> Clear All

SET-UP
<b>! WARNING !</b>
All data sets will be cleared !
<input checked="" type="checkbox"/> O.K.
CANCEL

#### 4.5.3. CALCULATION OF ΔT FROM STORED DATA

The coefficient ΔT is used to calculate the insulation resistance at a temperature other than the measurement temperature (see. § 4.3). It is the temperature difference at which the insulation resistance concerned is reduced to half its value.. This coefficient is variable: it depends on the type of insulation.

When it is not known, the instrument can calculate it from three or more stored measurements.

Attention, these 3 measurements must have been made by the same device (identical insulation resistance) but at 3 different temperatures, and the temperatures must have been recorded (function  $2nd + T^\circ$ ) at the same time as the measurements, without applying the correction (Resistance Correction OFF).

#### Procedure:

- In SET-UP, select **Calculate ΔT from Memory** and press ►.

The display unit proposes all values recorded with a temperature.

SET-UP	
Instr.Nr. 700016	SW Version 1.8
<input checked="" type="checkbox"/> Calculate ΔT from Memory	
Maximum Output Voltage	5100V
Set Default Parameter	
Clear Memory	
V Disturbance / V Output	3%
Buzzer	On
Power Down	On
BaudRate	9600 / RS 232

- Select at least 3 measurements using the ▲, ▼, ► or ◀.
- $\Delta T$  is calculated and recorded automatically once 3 stored measurements have been selected, and updated as more measurements are selected.
- The larger the number of measurements, the more accurate the calculation of  $\Delta T$ .

SET-UP			
$\Delta T$ Calculation for R/2			23.7°C
Obj. Test	Res.	Volt.	Temp.
47 99	228.5 M $\Omega$	5078V	23°C
13 59	208.5 M $\Omega$	5078V	30°C
13 58	178.5 M $\Omega$	5078V	37°C
02 03	328.5 M $\Omega$	5078V	23°C
02 02	328.5 M $\Omega$	5078V	23°C
02 01	328.5 M $\Omega$	5078V	23°C
01 02	328.5 M $\Omega$	5078V	23°C

#### 4.5.4. MAXIMUM OUTPUT VOLTAGE

- In the SET-UP menu, select **Maximum Output Voltage**.
- Adjust the maximum output voltage using the ► key, then the ▲ or ▼ keys.

This function prohibits the use of certain test voltages for the insulation measurement.

The instrument can then be used by less experienced persons for specific applications (telephony, aeronautics, etc.) where it is important not to exceed some maximum test voltage.

SET-UP	
Instr.Nr. 700016	SW Version 1.8
Calculate $\Delta T$ from Memory	
Maximum Output Voltage	5100V
Set Default Parameter	
Clear Memory	
V Disturbance / V Output	3%
Buzzer	On
Power Down	On
BaudRate	9600 / RS 232

For example, if the maximum output voltage is set to 750 V, the measurement will be made at 500 V in switch position 500 V, and at not more than 750 V in all other positions.

#### 4.6. LIST OF CODED ERRORS

If an anomaly is detected when the instrument is started up or in operation, the display indicates an error code. The format of this error code is a 1- or 2-digit number. This number identifies the anomaly and the action to be taken.

Error 10: There is an error in the user memory for storing measurement data. Use **Clear Memory** then **Clear All** in SET-UP to initialise the memory. Attention, all stored data will be lost.

Error 21: There is an error in the user settings. Use **Set Default Parameter** in SET-UP to initialise the settings.

Error 25: There is an error in the printer file format. A new format must be loaded into the instrument.

If the error message «Memory not initialized!» is displayed, proceed as described in Error 10.

All other errors require returning of the instrument for repair.



# 5. PROCEDURE

## 5.1. COURSE OF MEASUREMENTS

- Start up the instrument by setting the switch to the position corresponding to the measurement to be made.  
The instrument can measure insulation values from 10 kΩ to 10 TΩ, depending on the test voltage selected—from 40 to 5100 V<sub>DC</sub>.

The screen displays:

- the battery symbol and battery charge condition,
  - the test voltage selected,
  - the voltage, frequency and residual current on the input terminals,
  - the date and time.
- Connect the cables of the + and - terminals to the measurement points..
  - Connection diagram for measurement of low insulation values (example of a motor)

FIXED VOLTAGE	
<b>2500 V</b>	
Input voltage	△ 230 V AC
Frequency	50.0 Hz
Input current	24.6 nA
Date: 24.06.2008	Time: 15:31

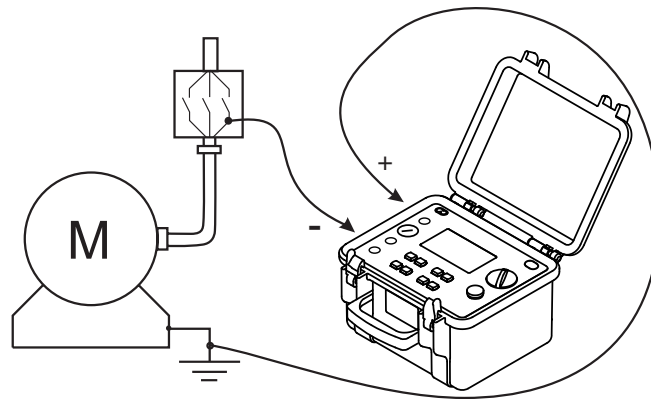

**To measure high insulation values (> 1 GΩ),** we recommend using guard terminal “G” to avoid leakage and capacitive effects or eliminate the influence of surface leakage currents. The guard terminal is connected to a surface where leakage currents may flow through dust and humidity, e.g. the insulation surface of a cable or transformer, between two measurement points.

- Connection diagram for measurement of high insulation values  
a) Example of a motor (reduction of capacitive effects)

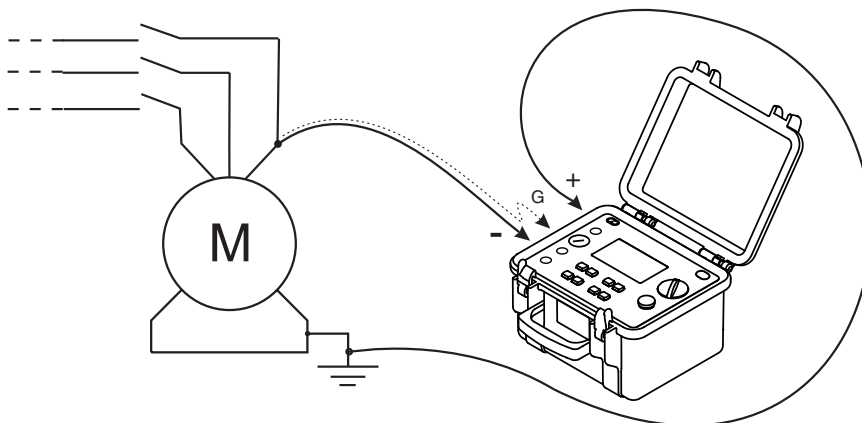

b) Example of a cable (reduction of surface leakage effects)

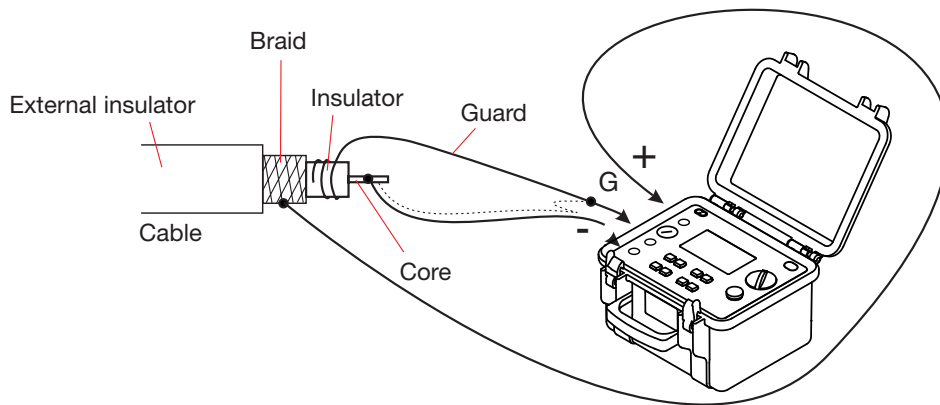

- Unless the step function mode is selected (**Adj. Step**), select the measurement mode to be used (Manual Stop, Manual Stop + DD, Timed Run, Timed Run + DD, DAR or PI) by pressing the MODE key (see § 4.1)
- A press on START/STOP triggers the measurement.  
If the voltage present is greater than the maximum allowed value, the measurement will be disabled (see § 3.2).  
The DISPLAY key can be used to consult all information available during the measurement.  
This information depends on the measurement mode selected (see § 4.2).  
If the insulation values displayed are very unstable, a digital filter can be activated by pressing SMOOTH to smooth them (see § 4.4).  
The alarm mode can be activated by pressing ALARM. An audible beep will sound if the measurement result is below the value defined in SET-UP (see § 4.5).
- Pressing START/STOP again stops the measurement.

The last result remains displayed until the next measurement is made, the MODE is changed or the switch is turned.

When the insulation measurements stop, the circuit tested is automatically discharged via a resistor in the instrument.

The DISPLAY key can be used to consult all information available after the measurement.  
This information depends on the measurement mode selected (see § 4.2).

If the measurement was in a “programmed-time test” mode (DAR, PI, Timed Run or Timed Run + DD), pressing GRAPH displays the insulation measurement versus time curve (see § 4.2).

Pressing T° enters the TEMPERATURE menu (see § 4.3).

## 5.2. STEP FUNCTION MODE (ADJ. STEP)

This test is based on the principle that an ideal insulation produces the same resistance whatever test voltage is applied.

Any negative variation of this resistance therefore means that the insulation is defective: the resistance of defective insulation decreases as the test voltage increases. This phenomenon is barely observed with “low” test voltages. In consequence, at least 2500 V should be applied.

The usual test condition is a voltage increasing in steps: 5 1-min steps.

Assessment of the result:

- a deviation of the resistance = f(test voltage) curve that exceeds 500 ppm/V generally indicates the presence of mould or other deterioration.
- a larger deviation or a sudden drop indicates the presence of localized physical damage (arcing, perforation of the insulation, etc.).

**Procedure:**

- In the SET-UP menu, select **Set Step Function 1, 2 or 3**.  
Example: here, step function n°3.

SET-UP	
Instr.Nr. 700016	SW Version 1.8
PI (m/m)	1.0/10
Set Step Function 1	
Set Step Function 2	
▣ Set Step Function 3	
Temperature Unit	Celsius
Default Probe Temperature	23°C
Rc Reference Temperature	40°C
ΔT for R/2	10°C

- Define the step function and the sample interval is automatically adjusted..

SET-UP		
Step Function 3 :		
Step	Voltage	Duration (h:m)
▣ 1	1000V	00:01
2	2000V	00:02
3	3000V	00:03
4	4000V	00:04
5	5000V	00:05
Total Run Time (h:m)		00:15
Sample Time (m:s)		00:30

- Once the step function is defined, set the switch to **Adj. Step** and select **Step Function n°3** using the ▲ or ▼ key.
- Start the measurement by pressing START/STOP

STEP FUNCTION 3	
Min: 1000 V	Max: 5000 V
	
Test Run Time 00:15:00	
Input voltage	0.1 V DC
Frequency	0.0 Hz
Input current	24.6 nA
Date: 24.06.2008	Time: 15:31

- During the measurement, the following screens can be accessed by pressing the DISPLAY key.

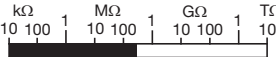
<b>234.5 MΩ</b>	
999 V	224.6 pA
Remaining Time 00:14:30	
	

<b>234.5 MΩ</b>	
999 V	224.6 pA
Remaining Time 00:14:15	
ΔR	--- MΩ
ΔV	300 V
ΔR/(R*ΔV) (ppm/V)	---
Capacitance	---

- At the end of the measurement, the following results are indicated:
  - the difference  $\Delta R$  in insulation resistance between the resistance at the highest test voltage and the resistance at the lowest test voltage,
  - the difference  $\Delta V$  between the highest and lowest test voltage,
  - the slope of the curve in ppm/V,
  - the capacitance.
- Pressing the *GRAPH* key displays the resistance versus time curve.  
Using the ◀ and ▶ keys, it is possible to move along the curves and view the exact values of each sample.

## 6. MEMORY / RS 232

### 6.1. RS 232 CHARACTERISTICS

- The baud rate can be set to 300, 600, 1200, 2400, 4800, 9600, or Parallel for printing on parallel printers via the optional serial / parallel adapter.  
This adjustment is performed in the SET-UP menu (see § 4.5)
- Data format: 8 data bits, 1 stop bit, no parity, Xon / Xoff protocol
- Connection to the serial printer: DB9F → DB9M
  - 2 → 2      5 → 5
  - 3 → 3      6 → 6
  - 4 → 4      8 → 8
- Connection to a PC or to a parallel printer: DB9F → DB9F
  - 2 → 3      5 → 5
  - 3 → 2      6 → 4
  - 4 → 6      8 → 7

**Note:** check that there is no connection between pins 6 and 8 of the RS232 port of the instrument.

### 6.2. STORING / RECALLING MEASUREMENT RESULTS (MEM/MR KEY)

#### 6.2.1. MEM PRIMARY FUNCTION (STORAGE)

This function is used to store the results in the instrument's RAM.

The results can be stored at addresses identified by an object number (OBJ) and a test number (TEST).

An object represents a "box" in which 99 tests can be stored. An object can thus represent a machine or an installation on which a number of measurements are performed.

- When the MEM key is activated, the following screen is displayed.

The flashing cursor identifies the next free Obj: Test location, here: 13: 59.

It is always possible to modify Obj.: Test to another free address using the ▲, ▼, ► or ◀ keys.

If an empty Obj. is selected, Test is set to 01. Press the MEM key again to store the current measurement results at the selected free location.

To store at an already occupied address (to overwrite a previously stored result) move the cursor in the list of stored results shown below the current measurement result and press the ► or MEM key. A warning screen is displayed and prompts the user to confirm or cancel erasure of the content of the address.

To validate, use the ► key.

- Pressing the MEM key again stores the current measurement results at the selected address.  
All information about a measurement will be stored at a single location in memory: date, time, test mode and voltage, insulation resistance, capacitance, residual current, and, possibly, DAR, PI, DD, resistance referred to the reference temperature, etc.

**Note:** To exit from the MEM menu without storing the results press the DISPLAY key.

- Memory space available

The bargraph indicates memory usage:

- black - already occupied memory space
- white - free memory space
- grey - amount of memory space the current measurement will need if stored (not always visible, because size depends on measurement)

Obj. Test	Date	Time	Fct.
▶ 13 59	28.04.2009	09:04	2550V
13 58	28.04.2009	09:00	1020V
02 03	14.04.2009	15:07	510V
02 02	14.04.2009	15:04	1020V
02 01	14.04.2009	14:56	5000V
01 02	01.04.2009	10:43	510V
01 02	01.04.2009	10:38	Ⓛ Ⓟ



The number of measurements that can be stored depends on the kind of measurements:

- “Programmed-time tests” ⌚ need a different amount of memory space depending on test duration and sample interval for recording intermediate results. A test duration of one hour and a sampling interval of 5 seconds takes the most amount of memory space; a maximum of 16 of such measurements can be stored.
- “Ordinary” measurements need much less memory space. Up to 1184 of such measurements can be stored.

### 6.2.2. MR SECONDARY FUNCTION

The MR function is used to recall any data from memory, whatever the active position of the rotary switch, except for the OFF and SET-UP positions.

When the MR key is activated, the following screen is displayed.

The flashing cursor identifies the highest occupied Obj. Test number, here 13: 59.

Use the ▲ and ▼ keys to move the cursor to the desired Obj. Test number.

Press the ► key to recall the measurement and show the results. Use the DISPLAY key to browse through the data.

Recall	MEMORY		
Obj. Test	Date	Time	Fct.
▶ 13 59	28.04.2009	09:04	2550V
13 58	28.04.2009	09:00	1020V⊕
13 57	28.04.2009	08:50	5000V
02 03	14.04.2009	15:07	510V
02 02	14.04.2009	15:04	1020V
02 01	14.04.2009	14:56	5000V
01 02	01.04.2009	10:43	510V⊕
01 02	01.04.2009	10:38	⌂ ⊕

Depending on the measurement mode a graph may be available by pressing the GRAPH key. Except for Adjustable Step measurements the TEMPERATURE menu is available by pressing the T° key. To enter the PRINT menu to print of the measurement, press the PRINT key.

To exit from the MR function, press MR again or turn the switch.

### 6.3. PRINTING MEASURED VALUES (PRINT KEY)

Pressing the PRINT key gives access to the menu below:

- Print result:  
Present measurement result: following a measurement or after access to the MR mode.
- Print memory  
Printing of stored measurements.
- Baud rate / Port  
Baud rate selected in the SET-UP menu (see § 4.5).

PRINT	
▶ Print result	
Print memory	
Baud rate / Port	9600 / RS 232

The COM symbol in the top right corner of the display indicates data transmission to the printer.

#### 6.3.1. PRESENT MEASUREMENT RESULT: PRINT RESULT

When this printing mode is selected, the following are printed, in order:

- general information concerning the measurement,
- the measurement result,
- if the T° function was activated, the measurement result referred to the reference temperature,
- for a Timed Run test, the list of recorded samples.

To stop printing, turn the rotary switch.

Depending on the measurement performed, the following forms are obtained.

- All measurements except step function measurements:

CHAUVIN ARNOUX C.A 6549

Instrument number: 700 016

Company: .....

Address: .....

.....

Tel.: .....

Fax: .....

Email: .....

Description: .....

OBJECT: 01 TEST: 01

(printed only in MR mode)

INSULATION RESISTANCE TEST

Date: 30.04.2009
Starting time: 14h55
Duration: 00:15:30
Temperature: 23°C
Relative humidity: . . . . %
Test voltage: 1000 V
Insulation resistance: 385 GOhm

Rc - calculated resistance 118.5 GOhm
at reference temperature 40°C
with ΔT for R/2 10°C

DAR (1'/30") 1.234
PI (10'/1') 2.345
DD - . - -
Capacitance 110 nF

Table with 3 columns: Elapsed time, Utest, Resistance. Rows show data at 00:00:10, 00:00:30, 00:00:50, and ...etc.

(after timed run test)

Date of next test: .././.....
Remarks: .....
Operator: .....
Signature: .....

■ Step function measurement:

CHAUVIN ARNOUX C.A 6549

Instrument number: 700 016

Company: .....
Address: .....
Tel.: .....
Fax: .....
Email: .....
Description: .....

OBJECT: 01 TEST: 01

(printed only in MR mode)

STEP FUNCTION TEST

Date: 30.04.2009
Starting time: 14h55
Duration: 00:15:30
Temperature: 23°C
Relative humidity: . . . . %

Table with 4 columns: Step N°, Duration h:m, True def. voltage, Resistance. Rows 1-5 show step data.

ΔR 604 GOhm
ΔV 4000 V

$\Delta R / (R \cdot \Delta V)$  (ppm/v)                    -57 ppm  
 Capacitance                                        100 nF

-----  
 Elapsed time    Utest                    Resistance  
 -----  
 00:00:10        1020 V            2.627 GOhm  
 00:00:30        1020 V            2.627 GOhm  
 00:00:50        1020 V            2.627 GOhm  
 ...etc

Date of next test:                    ..../.....  
 Remarks: .....  
 .....  
 Operator: .....  
 Signature: .....

### 6.3.2. PRINTING OF STORED MEASUREMENTS: PRINT MEMORY

When this printing mode is selected, the content of the memory is displayed.  
 Stored measurements to be printed are selected using the ▲, ▼, ► and ◀ keys.

Here, the measurements to be printed are:  
 13: 58  
 13: 57  
 02: 03  
 02: 02

PRINT			
Obj. Test	Date	Time	Fct.
13 59	28.04.2009	09:04	2550V
<b>13 58</b>	28.04.2009	09:00	1020V⊕
<b>13 57</b>	28.04.2009	08:50	5000V
<b>02 03</b>	14.04.2009	15:07	510V
<b>02 02</b>	14.04.2009	15:04	1020V
02 01	14.04.2009	14:56	5000V
01 02	01.04.2009	10:43	510V⊕
01 02	01.04.2009	10:38	⊕

- Once they have been selected,
- To start printing, press the PRINT key again.
  - To exit without printing, turn the rotary switch.
  - To stop printing, turn the rotary switch.

The printing of each group of data is reduced to the main results.  
 Depending on the measurements performed, the following models are obtained.

- All measurements except step function measurements:

CHAUVIN ARNOUX C.A 6549  
 Instrument number: 700 016  
 Company: .....  
 Address: .....  
 .....  
 Tel.: .....  
 Fax: .....  
 Email: .....  
 Description: .....

OBJECT: 01    TEST: 01

INSULATION RESISTANCE TEST  
 Date:                                        30.04.2009  
 Starting time:                            14h55  
 Duration:                                   00:15:30  
 Temperature:                            23°C  
 Relative humidity:                      . . . . %  
 Test voltage:                             1000 V  
 Insulation resistance :                385 GOhm  
 -----  
 Rc - calculated resistance 118.5 GOhm

at reference temperature 40°C  
with ΔT for R/2 10°C

-----  
DAR (1'30") 1.234  
PI (10'1') 2.345  
DD - . - -  
Capacitance 110 nF

OBJECT: 01 TEST: 02

INSULATION RESISTANCE TEST

Date: 28.04.2009  
Starting time: 17h55  
Duration: 00:17:30  
Temperature: 23°C  
Relative humidity: . . . . %  
Test voltage: 1000 V  
Insulation resistance : 385 GOhm

-----  
Rc - calculated resistance 118.5 GOhm  
at reference temperature 40°C  
with ΔT for R/2 10°C

-----  
DAR (1'30") 1.234  
PI (10'1') 2.345  
DD - . - -  
Capacitance 110 nF

...etc

Date of next test: ...././.....

Remarks: .....

Operator: .....

Signature: .....

■ Step function measurement:

CHAUVIN ARNOUX C.A 6549

Instrument number: 700 016

Company: .....

Address: .....

Tel.: .....

Fax: .....

Email: .....

Description: .....

OBJECT: 01 TEST: 01

STEP FUNCTION TEST

Date: 30.04.2009  
Starting time: 14h55  
Starting time: 00:15:30  
Temperature: 23°C  
Relative humidity: . . . . %

-----

Step N°	Duration h:m	True def. voltage	Resistance
1	00:10	1020 V	2.627 GOhm
2	00:10	2043V	2.411 GOhm
3	00:10	3060 V	2.347 GOhm
4	00:10	3755 V	2.182 GOhm
5	00:10	3237 V	2.023 GOhm

-----



$\Delta R$	604 GOhm
$\Delta V$	4000 V
$\Delta R / (R \cdot \Delta V)$ (ppm/v)	-57 ppm
Capacitance	100 nF

OBJECT: 01 TEST: 02

.... etc

Date of next test: ...././.....

Remarks: .....

.....

Operator: .....

Signature: .....

### 6.3.3. PRINTING WITH THE SERIAL-PARALLEL ADAPTER

- Connect the RS232 null - modem cable to the C.A 6549.
- Connect this cable to the adapter, then the adapter to the printer cable.
- Power up the printer.
- Power up the C.A 6549.
- Select “--- / Parallel” for the Baud Rate setting in SET-UP.
- Press PRINT.

 **ATTENTION:** This adapter is designed to be used only with the C.A 6543, C.A 6547, and C.A 6549 and is unsuitable for any other application.

## 7. SPECIFICATIONS

### 7.1. REFERENCE CONDITIONS

Influence quantities	Reference values
Temperature	23 ± 3 °C
Relative humidity	45 to 55 % RH
Supply voltage	9 to 12 V
Frequency range	DC and 15.3 to 65 Hz
Capacitance in parallel on resistance	0 µF
Electric field	nil
Magnetic field	< 40 A/m

### 7.2. CHARACTERISTICS PER FUNCTION

#### 7.2.1. VOLTAGE

##### ■ Characteristics

Measurement range	1,0 ... 99,9 V	100 ... 999 V	1000 ... 2500 V	2501 ... 4000 V
Resolution	0,1 V	1 V	2 V	2 V
Accuracy	1% +5 ct	1% +1 ct		
Frequency range	DC or 15 ... 500 Hz			DC

##### ■ Input impedance: 750 kΩ to 3 MΩ depending on voltage measured

Measured voltage	1.0 ... 900 V	901 ... 1800 V	1801 ... 2700 V	2701 ... 4000 V
Input impedance	750 kΩ	1.5 MΩ	2.25 MΩ	3 MΩ

##### ■ Measurement category: 1000 V CAT III or 2500 V CAT I (transients ≤ 2.5 kV)

#### 7.2.2. LEAKAGE CURRENT MEASUREMENT

##### ■ Before an insulation measurement:

Measurement range DC	0.000 ... 0.250 nA	0.251 ... 9.999 nA	10.00 ... 99.99 nA	100.0 ... 999.9 nA	1.000 ... 9.999 µA	10.00 ... 99.99 µA	100.0 ... 999.9 µA	1000 ... 3000 µA
Resolution	1 pA		10 pA	100 pA	1 nA	10 nA	100 nA	1 µA
Accuracy	15% + 10 ct	10%	5%					

##### ■ During an insulation measurement:

Measurement range DC	0.000 ... 0.250 nA	0.251 ... 9.999 nA	10.00 ... 99.99 nA	100.0 ... 999.9 nA	1.000 ... 9.999 µA	10.00 ... 99.99 µA	100.0 ... 999.9 µA	1000 ... 3000 µA
Resolution	1 pA		10 pA	100 pA	1 nA	10 nA	100 nA	1 µA
Accuracy	15% + 10 ct	10%	5%	3%				

#### 7.2.3. INSULATION RESISTANCE

##### ■ Method: voltage-current measurement as per IEC 61557-2 or per DIN VDE 0413 Part 1/09.80.

##### ■ Nominal output voltage: 500, 1000, 2500, 5000 V<sub>DC</sub> (or adjustable from 40 V to 5100 V) Accuracy ± 2% adjustable from 40 to 1000 V<sub>DC</sub> in 10-V steps adjustable from 1000 to 5100 V<sub>DC</sub> in 100-V steps

##### ■ Nominal current: ≥ 1 mA<sub>DC</sub>

##### ■ Short-circuit current: < 1.6 mA<sub>DC</sub> ± 5% (3.1 mA maximum at start-up)

■ **Maximum acceptable AC voltage:**  $(1.1 + dISt) \times U_n + 60 \text{ V}$

■ **Measurement ranges:**

- 500 V : 10 kΩ ... 1.999 TΩ
- 1000 V : 10 kΩ ... 3.999 TΩ
- 2500 V : 10 kΩ ... 9.99 TΩ
- 5000 V : 10 kΩ ... 9.99 TΩ
- Var 40 V ... 5100 V: to be interpolate between the fixed values above.

■ **Accuracy and resistance range in fixed-voltage mode**

Test voltage	500 V - 1000 V - 2500 V - 5000 V		
Specified measurement range	10 ... 999 kΩ 1.000 ... 3.999 MΩ	4.00 ... 39.99 MΩ	40.0 ... 399.9 MΩ
Resolution	1 kΩ	10 kΩ	100 kΩ
Accuracy	±5% + 3 ct		

Test voltage	500 V - 1000 V - 2500 V - 5000 V				1000 V 2500 V 5000 V	2500 V 5000 V
Specified measurement range	400 ... 999 MΩ 1.000 ... 3.999 GΩ	4.00 ... 39.99 GΩ	40.0 ... 399.9 GΩ	400 ... 999 GΩ 1.000 ... 1.999 TΩ	2.000 ... 3.999 TΩ	4.00 ... 9.99 TΩ
Resolution	1 MΩ	10 MΩ	100 MΩ	1 GΩ		10 GΩ
Accuracy	±5% + 3 ct			±15% + 10 ct		

■ **Precision and resistance range in variable- / adjustable- voltage mode**

Max. resistance measured = test voltage / 250 pA

Test voltage	40 ... 160 V	170 ... 510 V	520 ... 1500 V	1600 ... 5100 V
Min. measured resistance	10 kΩ	30 kΩ	100 kΩ	300 kΩ
Max. measured resistance	160.0 GΩ ... 640.0 GΩ	640.0 GΩ ... 2.040 TΩ	2.080 TΩ ... 6.00 TΩ	6.40 TΩ ... 10.00 TΩ

**Note:** the precision in variable mode must be interpolated from the precision tables provided for fixed test voltages.

■ **Measurement of DC voltage during insulation test**

Specified measurement range	40.0 ... 99.9 V	100 ... 1500 V	1501 ... 5100 V
Resolution	0.1 V	1 V	2 V
Accuracy	1%		

During the measurement, the maximum acceptable voltage on the terminals is (AC or DC):

$U_{\text{peak}} = U_{\text{nominal}} \times (1.1 + dISt)$  where  $dISt = 3\%, 10\%$  or  $20\%$

■ **Measurement of DC voltage during discharge phase of an insulation test**

Specified measurement range	25 ... 5100 V
Resolution	0.2% $U_n$
Accuracy	5% + 3 ct

■ Typical curves, test voltage versus load

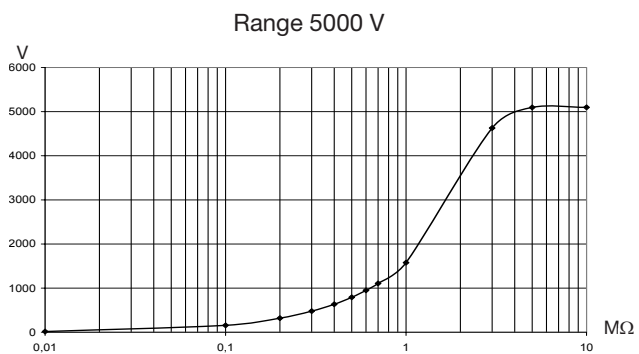
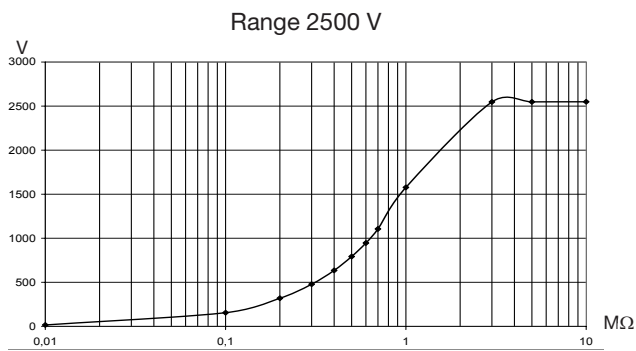
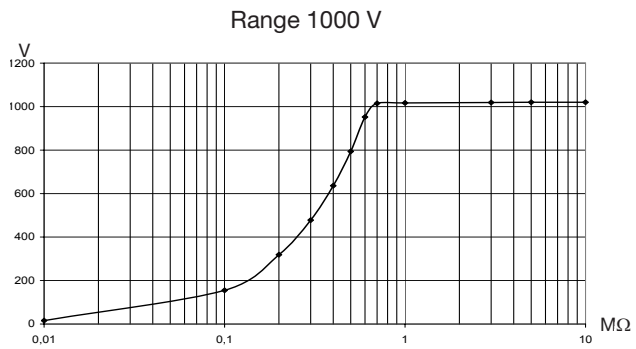
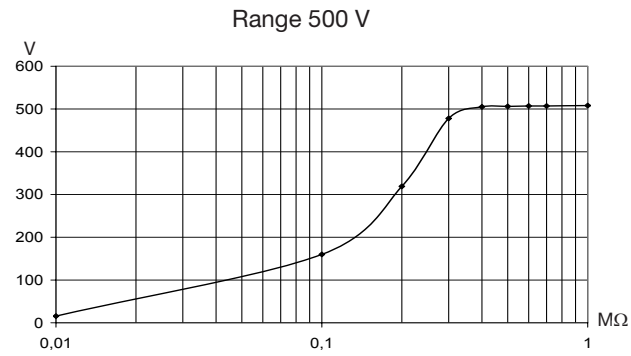

■ Calculation of the DAR and PI terms

Specified range	0.02 ... 50.00
Resolution	0.01
Accuracy	± 5% + 1 ct

■ **Calculation of the DD term**

Specified range	0.02 ... 50.00
Resolution	0.01
Accuracy	± 10% + 1 ct

■ **Capacitance measurement (after discharge of tested element)**

Specified measurement range	0.005 ... 9.999 µF	10.00 ... 49.99 µF
Resolution	1 nF	10 nF
Accuracy	± 10% + 1 ct	± 10%

### 7.3. POWER SUPPLY

■ **The instrument is supplied by:**

NiMH rechargeable batteries - 8 x 1.2V / 3.5 Ah  
 External charging: 85 to 256 V / 50-60 Hz

■ **Minimum battery life (as per IEC 61557-2)**

Test voltage	500 V	1000 V	2500 V	5000 V
Nominal load	500 kΩ	1 MΩ	2.5 MΩ	5 MΩ
Number of 5-s measurements on nominal load (with 25-s pauses between measurements)	6500	5500	4000	1500

■ **Mean battery life**

Assuming a 1-minute DAR measurement 10 times a day and a 10-minute PI measurement 5 times a day, the battery life will be approximately 15 working days, or 3 weeks.

■ **Charging time**

6 hours to recover 100% capacity (10 hours if the battery is completely run down).  
 0.5 hours to recover 10% capacity (battery life approximately 2 days).

**Remark:** it is possible to charge the batteries while making insulation measurements, provided that the values measured are greater than 20 MΩ. In that case, the charging time is longer than 6 hours, and depends on the frequency of the measurements made.

### 7.4. ENVIRONMENTAL CONDITIONS

■ **Range of use**

-10 to 40°C, while batteries are charging  
 -10 to 55°C, during measurement  
 10 to 80 % relative humidity

■ **Storage**

-40 to 70°C  
 10 to 90 relative humidity

■ **Altitude:** < 2000 m

### 7.5. CONSTRUCTION SPECIFICATIONS

- Overall dimensions of the instrument (L x W x H): 270 x 250 x 180 mm
- Weight: approximately 4.3 kg

## 7.6. COMPLIANCE WITH INTERNATIONAL STANDARDS

- Electrical safety as per: IEC 61010-1, IEC 61557
- Double insulation
- Pollution level: 2
- Measurement category: III
- Maximum voltage relative to earth: 1000 V

### 7.6.1. ELECTROMAGNETIC COMPATIBILITY

Emissions and immunity in an industrial setting compliant with EN 61326-1.

### 7.6.2. MECHANICAL PROTECTIONS

- IP 53 as per IEC 60529
- IK 04 as per IEC 50102

## 7.7. VARIATIONS WITHIN DOMAIN OF USE

Influence quantity	Range of influence	Quantity influenced <sup>(1)</sup>	Influence	
			Typical	Maximum
Battery voltage	9 ... 12 V	V MΩ	< 1 ct < 1 ct	2 ct 3 ct
Temperature	-10 ... +55°C	V MΩ	0.15%/10°C 0.20%/10°C	0,3%/10°C +1 ct 1%/10°C + 2 ct
Humidity	10 ... 80% HR	V MΩ (10 kΩ ... 40 GΩ) MΩ (40 GΩ ... 10 TΩ)	0.2% 0,2% 0.3%	1% +2 ct 1% +5 ct 15% +5 ct
Frequency	15 ... 500 Hz	V	3%	0.5% +1 ct
AC voltage superimposed on test voltage	0 ... 20%Un	MΩ	0.1%/ % Un	0.5%/ % Un +5 ct

(1): The DAR, PI and DD terms and the capacitance and leakage current measurements are included in the quantity "MΩ".

## 8. MAINTENANCE

 **Except for the fuse, the instrument contains no parts that can be replaced by personnel who have not been specially trained and accredited. Any unauthorized repair or replacement of a part by an “equivalent” may gravely impair safety.**

### 8.1. SERVICING

#### 8.1.1. BATTERY CHARGING

If the instrument is charging in the OFF position: the battery symbol is displayed and the 3 bars flash throughout the charging - “Charging Battery” is also indicated.

When the battery is full, the symbol and its 3 bars are lit steadily and “Battery Full” is indicated.

If the instrument is charging in a measurement position: the battery symbol flashes.

There is no full charge indication. The “Battery Full” indication is displayed only when the instrument is returned to the OFF position.

The battery should be replaced by a repairer approved by CHAUVIN ARNOUX.

**Attention: changing the battery causes a loss of stored data.**

Carry out a complete erasure of the memory, in the SET-UP menu (see § 4.5), to be able to use the MEM / MR functions again.

#### 8.1.2. REPLACING THE FUSES

If “Guard fuse blown!” appears on the display, you must change the fuse accessible on the front panel after checking that none of the terminals is connected and that the switch is OFF.

 For safety reasons this fuse must always be replaced by an identical model.  
Exact type of fuse (printed on the front panel label): FF - 0.1 A - 380 V - 5 x 20 mm - 10 kA

**Remark:** This fuse is in series with a 0.5 A / 3 kV internal fuse active only if there is a major fault in the instrument. If the display unit still indicates “Guard fuse blown!” after the fuse on the front panel is changed, the instrument must be sent in for servicing (see § 8.2).

#### 8.1.3. CLEANING

Disconnect the unit completely and turn the rotary switch to OFF.

Use a soft cloth, dampened with soapy water. Rinse with a damp cloth and dry rapidly with a dry cloth or forced air. Do not use alcohol, solvents, or hydrocarbons.

#### 8.1.4. STORAGE

If the instrument is left unused for a long time (more than two months), fully charge the instrument before using it again.

### 8.2. METROLOGICAL CHECK

 **Like all measuring or testing devices, the instrument must be checked regularly.**

This instrument should be checked at least once a year. For checking and calibration, contact one of our accredited metrology laboratories (information and contact details available on request), at our Chauvin Arnoux subsidiary or the branch in your country.

### 8.3. REPAIR

For all repairs before or after expiry of warranty, please return the device to your distributor.

## 9. WARRANTY

---

Except as otherwise stated, our warranty is valid for **twelve months** starting from the date on which the equipment was sold. Extract from our General Conditions of Sale provided on request.

The warranty does not apply in the following cases:

- Inappropriate use of the equipment or use with incompatible equipment;
- Modifications made to the equipment without the explicit permission of the manufacturer's technical staff;
- Work done on the device by a person not approved by the manufacturer;
- Adaptation to a particular application not anticipated in the definition of the equipment or not indicated in the user's manual;
- Damage caused by shocks, falls, or floods.



## 10. TO ORDER

**C.A 6549 Megohmmeter** ..... P01139703

Delivered with bag containing:

- 2 x 3-m safety leads, fitted with a HV plug and a HV alligator clip (red and blue)
- 1 x 3-m guarded safety lead, fitted with a HV rear pick up plug and a HV alligator clip (black)
- 1 2-m mains power lead
- 1 cable with rear pick up plug, 0.35 m
- 1 DB9F-DB9F cable
- 1 DB9M-DB9M adapter
- User's manuals on CD (one per language).

### 10.1. ACCESSORIES

PC software ..... P01102095  
Serial printer ..... P01102903  
Serial-parallel adapter ..... P01101941  
Set of 2 HV cables with  $\varnothing$ 4mm safety connector (red/guarded black) 3m ..... P01295231  
Set of 2 alligator clips (red/black) ..... P01295457Z  
Set of 2 test contact tips (red/black) ..... P01295458Z  
HV cable with  $\varnothing$ 4mm safety connector (blue) 3m + alligator clip (blue) ..... P01295232  
HV cable with alligator clip, blue, 8 m long ..... P01295214  
HV cable with alligator clip, red, 8 m long ..... P01295215  
HV cable with alligator clip and earth pick up plug, 8 m long ..... P01295216  
HV cable with alligator clip, blue, 15 m long ..... P01295217  
HV cable with alligator clip, red, 15 m long ..... P01295218  
HV cable with alligator clip and earth pick up plug, 15 m long ..... P01295219  
Thermocouple thermometer, CA 861 ..... P01650101Z  
Thermo-hygrometer, CA 846 ..... P01156301Z

### 10.2. REPLACEMENT PARTS

3 HV cables (red + blue + guarded black) - 3 m ..... P01295220  
035 m cord with rear pick up plug ..... P01295221  
N° 8 bag for accessories ..... P01298061A  
Fuse FF 01 A - 380 V - 5 x 20 mm - 10 kA (set of 10) ..... P03297514  
Battery 96 V - 35 Ah - NiMh ..... P01296021  
RS 232 cable to PC DB 9F - DB 25F x2 ..... P01295172  
RS 232 cable to printer DB 9F - DB 9M No01 ..... P01295173  
Mains power supply cable 2P ..... P01295174



02 - 2015

Code 689646C02 - Ed. 2

**DEUTSCHLAND - Chauvin Arnoux GmbH**

Ohmstraße1 - 77694 Kehl / Rhein  
Tel: (07851) 99 26-0 - Fax: (07851) 99 26-60

**UNITED KINGDOM - Chauvin Arnoux Ltd**

Unit 1 Nelson Ct - Flagship Sq - Shaw Cross Business Pk  
Dewsbury, West Yorkshire - WF12 7TH  
Tel: 01924 460 494 - Fax: 01924 455 328

**ITALIA - Amra SpA**

Via Sant' Ambrogio, 23/25 - 20846 Macherio (MB)  
Tel: 039 245 75 45 - Fax: 039 481 561

**ÖSTERREICH - Chauvin Arnoux Ges.m.b.H**

Slamastrasse 29/2/4 - 1230 Wien  
Tel: 01 61 61 9 61-0 - Fax: 01 61 61 9 61-61

**SCANDINAVIA - CA Mätssystem AB**

Sjöflygvägen 35 - SE 18304 TÄBY  
Tel: +46 8 50 52 68 00 - Fax: +46 8 50 52 68 10

**SCHWEIZ - Chauvin Arnoux AG**

Moosacherstrasse 15 - 8804 AU / ZH  
Tel: 044 727 75 55 - Fax: 044 727 75 56

**中国 - 上海浦江埃纳迪斯仪表有限公司**

上海市虹口区祥德路381号3号楼3楼  
Tel: +86 21 65 21 51 96 - Fax: +86 21 65 21 61 07

**ESPAÑA - Chauvin Arnoux Ibérica S.A.**

C/ Roger de Flor, 293 - 1a Planta - 08025 Barcelona  
Tel: 90 220 22 26 - Fax: 93 459 14 43

**MIDDLE EAST - Chauvin Arnoux Middle East**

P.O. BOX 60-154 - 1241 2020 JAL EL DIB (Beirut) - LEBANON  
Tel: (01) 890 425 - Fax: (01) 890 424

**USA - Chauvin Arnoux Inc - d.b.a AEMC Instruments**

200 Foxborough Blvd. - Foxborough - MA 02035  
Tel: (508) 698-2115 - Fax: (508) 698-2118

<http://www.chauvin-arnoux.com>

190, rue Championnet - 75876 PARIS Cedex 18 - FRANCE

Tél. : +33 1 44 85 44 85 - Fax : +33 1 46 27 73 89 - info@chauvin-arnoux.fr

Export : Tél. : +33 1 44 85 44 38 - Fax : +33 1 46 27 95 59 - export@chauvin-arnoux.fr