

ARITERM

For a sustainable future.

INSTALLATION, OPERATION AND MAINTENANCE

♦ BioComp 40 - 150 kW



TABLE OF CONTENTS

General	3
Contents of delivery.....	3
Transportation, storage and opening the package.....	4
Technical data.....	5
Dimensions.....	6
Boiler installation.....	7
Pipe installation	8-9
Electrical installation	10-13
Flue gas fan installation.....	14
Burner installation.....	15
Ash screw installation	16
Commissioning	17
Maintenance	18-20
Warranty, decommissioning and contact information.....	21
Declaration of conformity.....	22
Standard delivery	23
Accessories.....	24-25
Spare parts	26-27
Notes	28-31

■ General

The BioComp-series bio boiler is economical, manageable and environmentally friendly. All the boilers in the series are available as either right or left handed, with maintenance and ash removal hatches in front. The boiler is equipped with an integrated ash chamber as standard. The boiler can be equipped with Ariterm MultiJet-, BioJet- and HakeJet burners, or Axon-pellet burner. The fuels that can be used with the boiler, depending on the burner, are wood chip, pellet, peat, sawdust etc.

The standard package of the BioComp -boiler includes an automatic convection part cleaning, a flue gas fan and a plate heat exchanger with pump. The automatic convection part cleaning significantly aids/reduces maintenance work required and guarantees good efficiency. The flue gas fan ensures the required underpressure in the fire chamber. Large maintenance and cleaning hatches facilitate the cleaning of the BioComp -boiler. Available accessories include e.g. fire chamber ash screw and ash box.

This manual applies to models:	Left	Right
BioComp 40 kW	5033589	5033590
BioComp 60 kW:	5033591	5033592
BioComp 80 kW:	5033593	5033594
BioComp 120 kW:	5033595	5033596
BioComp 150 kW:	5033597	5033598

■ Contents of delivery (Page 23)

The boiler delivery includes:

- Bio boiler with hatches
- Cleaning equipment
- Smoke duct and flue gas fan
- Automatic convection cleaning
- Plate heat exchanger and pump

Accessories:

- Arimatic 200 control centre
- BioComp -control (automatic cleaning, heat exchanger pump, flue gas fan) COMING!
- Fire chamber ash screw and ash box
- Fire chamber ash screw with extra length
- Secondary ash screw
- Convection part ash screw and ash box
- Electric resistance with thermostat 6 or 9 kW (to be installed on the boiler's electric resistance connection)
- Oil burner equipment (hatch set for BioComp 60 kW model)
- Axon/PX52 pellet burner equipment (hatch set for BioComp 60 and 80 kW models)
- BioJet/HakeJet adapter flange (BioComp 60/80/120/150-models)

■ TRANSPORTATION, STORAGE AND OPENING THE PACKAGE

■ Reception

The boiler is delivered in a wooden frame. It is on a platform from which the boiler can be lifted safely. The package should be opened as close to the installation site as possible. The boiler has been insured against possible transport damage from the factory to the first point of storage by the manufacturer. It is important for the receiver of the boiler to check the condition of the boiler before accepting the delivery. In case of damage, the dealer should be contacted immediately.

■ Storage

The boiler can be stored outside if it is covered from the rain. However, the recommended storage of the boiler is indoors.

■ Opening the package

After opening the package, use the equipment list (appendix 1) to check that all the accessories have been delivered.

Disposing of the package: the plastic hood is landfill waste, the planks can be burned.

TECHNICAL DATA

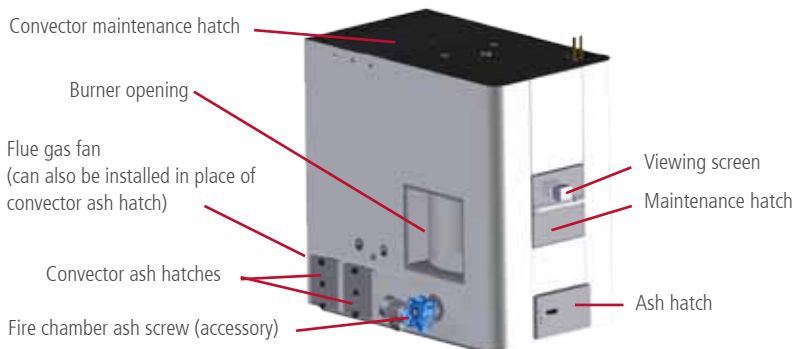

Boiler	BioComp 40	BioComp 60	BioComp 80	BioComp 120	BioComp 150
Power, kW	40	60	80	120	150
Weight, kg	495	640	786	1035	1193
Volume, l	175	280	330	448	567
Max operating pressure, bar	3,0	3,0	3,0	3,0	3,0
Max operating temp., °C	130	130	130	130	130

Fire chamber measurements	BioComp 40	BioComp 60	BioComp 80	BioComp 120	BioComp 150
Height, mm	895	895	895	1095	1095
Diameter, mm	430	500	640	720	820
Volume, m ³	0,13	0,18	0,29	0,45	0,58
Fire surface load, kW/m ²	11,1	10,6	10,5	10,8	10,5
Burner opening, mm x mm	250x250	360x360	400x400	440x440	480x480
Chimney duct, Ø mm	139	139	139	139	139
Chimney, min Ø, mm	150	150	150	200	200
Chimney min length, m	5	5	5	5	5
Flow/Return, DN	50	50	50	50	50
Expansion connection, DN	25	25	25	25	25
Thermostat connection, DN	15	15	15	15	15
Heat exchanger, power kW	57	57	75	120	150
Heat exchanger pump	UPS 25-40	UPS 25-40	UPS 25-60	UPS 25-80	UPS 25-80

DIMENSIONS

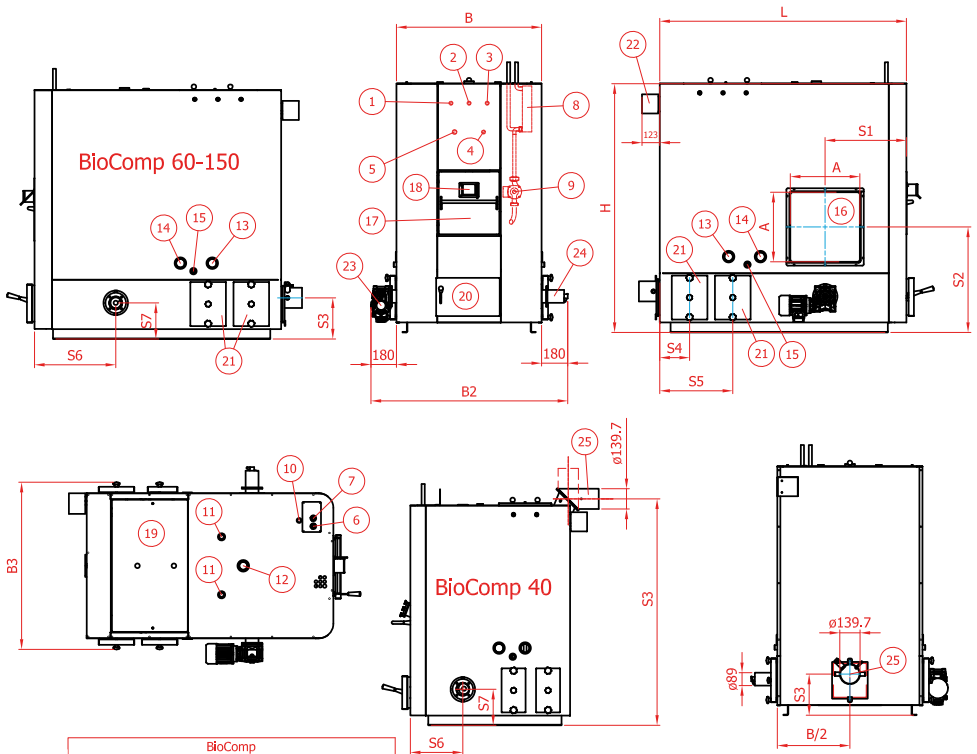

	BioComp				
	40	60	80	120	150
A	250	360	400	440	480
B	610	680	820	900	1000
B2	970	1040	1180	1260	1360
B3	760	830	970	1050	1150
H	1520	1520	1520	1720	1720
L	1100	1260	1420	1550	1700
S1	360	380	455	510	560
S2	610	670	690	710	730
S3	1563	284	284	284	284
S4	152	147	155	205	205
S5	390	425	435	505	505
S6	360	380	455	510	560
S7	250	250	250	250	250

- | | |
|--|--|
| 1. Boiler water overheating protection DN 15 | 14. Electric resistance connection DN 50 |
| 2. Spare DN 15 | 15. Drain connection DN 20 |
| 3. Boiler water temperature sensor DN 15 | 16. Burner opening, right or left side |
| 4. Fire chamber sensor connection DN 15 (BC40 DN 20) | 17. Maintenance hatch |
| 5. Fire chamber sensor connection DN 20 (BC40 DN 15) | 18. Viewing screen |
| 6. Cold water ϕ 22 Cu | 19. Convector cleaning hatch |
| 7. Warm water ϕ 22 Cu | 20. Ash hatch |
| 8. Plate heat exchanger | 21. Cleaning hatch |
| 9. Heat exchanger pump | 22. Convector cleaner motor |
| 10. Bleeding screw for the water network | 23. Ash screw motor |
| 11. Expansion / relief valve DN 25 | 24. Ash screw |
| 12. Flow to network DN 50 | 25. Smoke duct ϕ 139 |
| 13. Return from network DN 50 | |

■ BOILER INSTALLATION

The installation of the boiler can only be conducted by a professionally qualified installer. The installation should be carried out so that it fills at least the country's minimum requirements applicable to heating systems in question. The boiler's electrical installations can only be carried out by a professional with the required proficiencies.

■ Space requirements

The boiler room must meet the local fire classification requirements. In the front and on one side of the boiler there should be approximately 1 m of free space for cleaning and maintenance operations. Above the boiler there should be at least the boiler's height of free space for cleaning the convection ducts. Furthermore, enough space should be left for the maintenance of the flue gas fan. In the space plan the space required by the attached burner and ash screws must also be taken into account.

■ Flue connection and combustion air opening

The BioComp boiler is equipped with a flue gas fan which ensures the required underpressure in the fire chamber. The standard boiler has a chimney duct at the back of the boiler but the duct can also be transferred to either side by changing places with the convector ash hatch.

CHIMNEY RECOMMENDATION: stainless or acid proof

	BioComp 40	BioComp 60	BioComp 80	BioComp 120	BioComp 150
Minimum Ø	Ø 150 mm	Ø 150 mm	Ø 150 mm	Ø 200 mm	Ø 200 mm
Minimum length	5 m	5 m	5 m	5 m	5 m
Combustion air opening	200 cm ² 140 x 140 mm Ø 160 mm	300 cm ² 180 x 180 mm Ø 200 mm	400 cm ² 200 x 200 mm Ø 230 mm	600 cm ² 250 x 250 mm Ø 280 mm	750 cm ² 280 x 280 mm Ø 300 mm

IMPORTANT!!

Availability of sufficient amount of combustion air is important for clean burning and sound functioning of the boiler. The combustion air opening must not be covered up. The free area of the combustion air opening must be approximately 500 cm² / 100 kW.

Keep the boiler room door closed when adjusting the burner! This ensures that the combustion air supply corresponds to the normal operating situation.

PIPE INSTALLATION

Pipe installations

The BioComp -boiler has been designed to operate without an accumulator tank. The boiler has a large water capacity and it has its own heat exchanger for production of domestic hot water. It is, however, possible to install an accumulator tank if the boiler is used intermittently or momentary peaks in consumption such require. The thermostats, overheating protection equipment and other safety devices are installed according to the burner instructions. Before the boiler installation, the heating network must be flushed and tested using a hydraulic pressure test. The sealing of the connections must be checked after the installation. The factory is not responsible for damage caused by leaking connections.

NOTE! The boiler circulation ensures that the return water temperature is high enough (min 70 °C.). This is important in order to ensure good combustion conditions and to prevent corrosion to the boiler body caused by the cold return water (see installation example below).

Installation example

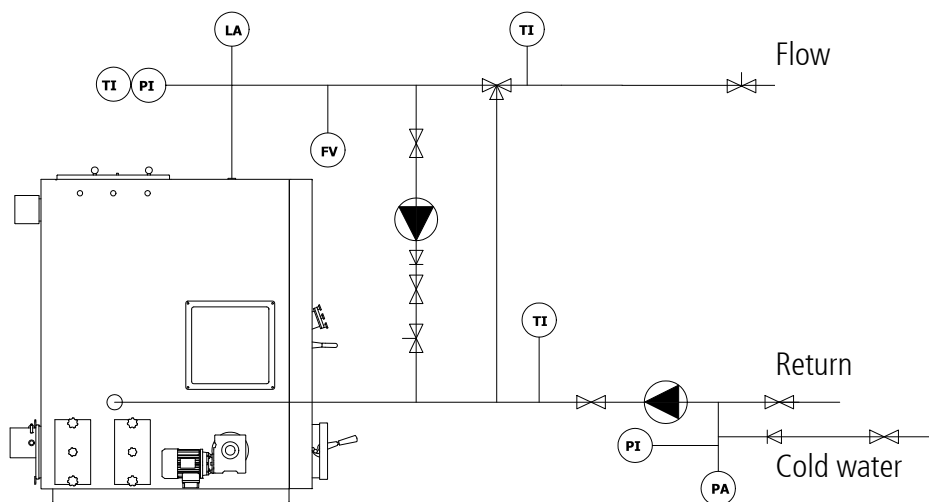

TI/PI	Thermometer/Pressure gauge
TI	Thermometer
FV	Safety valve
PA	Expansion tank
LA	Low-water cut off device

■ PIPE INSTALLATION

■ Safety valve installation (not included in the delivery)

The valve must be CE-marked with the maximum opening pressure of 3,0 bars and the minimum size of DN 25. The safety valve must be chosen according to the highest pressure class of the device combination. Do not install a closing device (valve or similar) between the valve and the boiler. The outlet pipe must be measured and installed so that it does not limit the outlet capacity of the valve or cause a dangerous situation when the valve is in operation.

WARNING! Hot pressurised steam comes out of the valve when it is in operation!

■ Expansion tank

The size of the expansion tank is chosen as follows:

Closed system: According to the instructions of the expansion tank manufacturer

System capacity (litres)	Opening pressure (bars)	Pre-pressure (bars)	Tank capacity (litres)	
			70°C	90°C
500	3,0	0,5	35	80
1000	3,0	0,5	80	140
1500	3,0	0,5	80	140
2000	3,0	0,5	140	200

System capacity = boiler capacity (+ accumulator capacity) + pipe capacity + radiator capacity

■ Domestic hot water production

The BioComp -series boilers have an efficient plate heat exchanger for domestic hot water production which means that a separate accumulator is not usually needed. The pressure capacity of the plate heat exchanger is 10 bars. An external heat exchanger of a desired capacity can also be connected to the system.

■ ELECTRICAL INSTALLATION

The standard features of the BioComp -boiler include a heat exchanger pump and an automatic cleaning. These have been connected to the terminal box at the factory. The flue gas fan is also a standard feature. The fan can in 60-150 kW models be installed either at the back of the boiler or on the side instead of the ash hatch. The 40 kW model has an integrated flue fan at the back of the boiler. The functions can be controlled by Arimatic 200 control centre or a BioComp -control centre (COMING).

■ BioComp -control centre (coming)

If the system is not equipped with the Arimatic 200 -control centre the BioComp -boiler can be equipped with the BioComp -control centre instead.

BioComp -control centre includes the following functions:

- Heat exchanger pump control (on/off)
- Convector cleaner motor control (run and delay time)
- Flue gas fan
(constant power on power- and standby-modes)



The control centre can be used e.g. with Axon/PX52 -pellet burner. The flue gas fan is actuated by the running data collected from the pellet burner.

■ Arimatic 200 -control centre

Arimatic 200 control centre includes the controls for the features of the BioComp -boiler (ash screw, automatic cleaning, heat exchanger pump and underpressure controlled flue gas fan).

The wiring diagram of the BioComp-boiler is presented on the next page. More detailed wiring instructions will be provided with the AM200 centre.

WIRING DIAGRAM

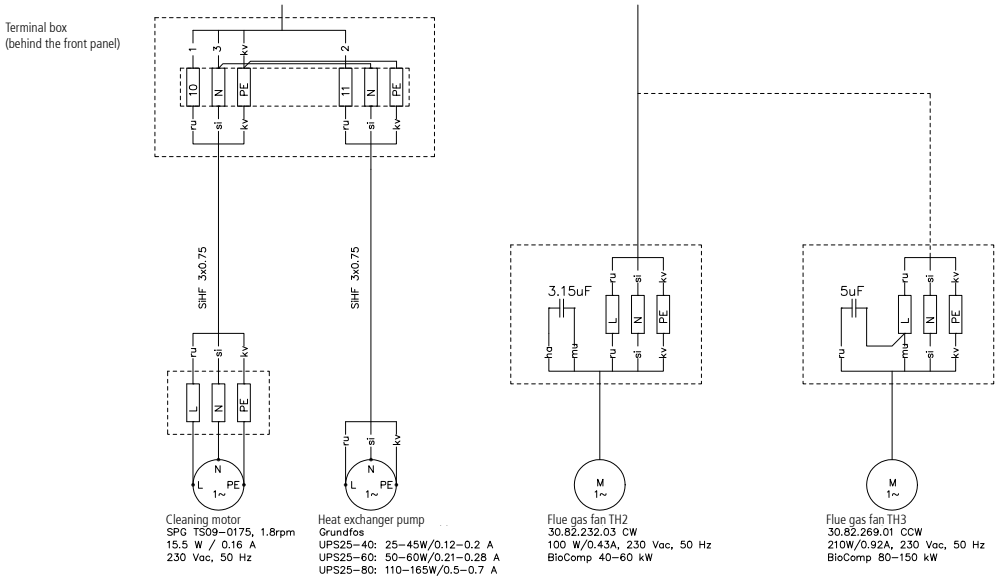

Terminal box



1. Open the two screws at the bottom of the front panel of the boiler.



2. Open the front panel fastening screws located on the top of the boiler.



3. Cleaning motor (10) and heat exchanger pump (11) terminal box.

■ ARIMATIC 200 - SENSOR INSTALLATION

Items supplied with the Arimatic 200 control centre:

- boiler water temperature sensor
- overheating protector
- fire chamber overpressure switch
- fire chamber underpressure transmitter
- fire chamber connection

The sensors can be connected to a joint terminal box outside the boiler from which a multipole cable can be brought to the control centre. The boiler water temperature sensor is connected to the connection on the right side connection beside the heat exchanger. The overheating thermostat is installed to the left side connection, cable outlet upwards. Fire chamber connection is rotated into place and the copper pipes are bent upwards. Fire chamber overpressure switch and underpressure transmitter are placed on e.g. a holder on top of the boiler. More detailed connecting instructions are supplied with the centre.

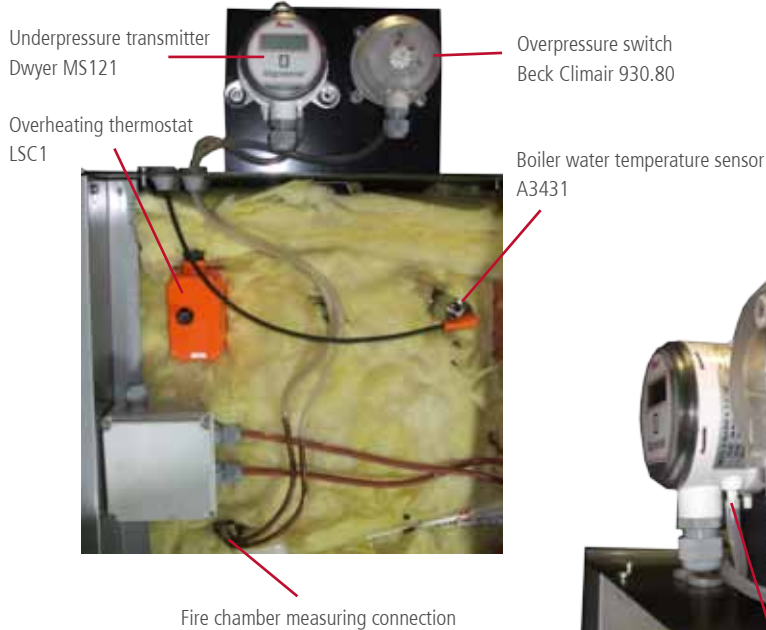

NOTE! The hose is attached to the connection on the underpressure transmitter. In the overpressure switch the hose is attached to the lower connection and the plug from the upper connection is removed.

■ Wiring diagram

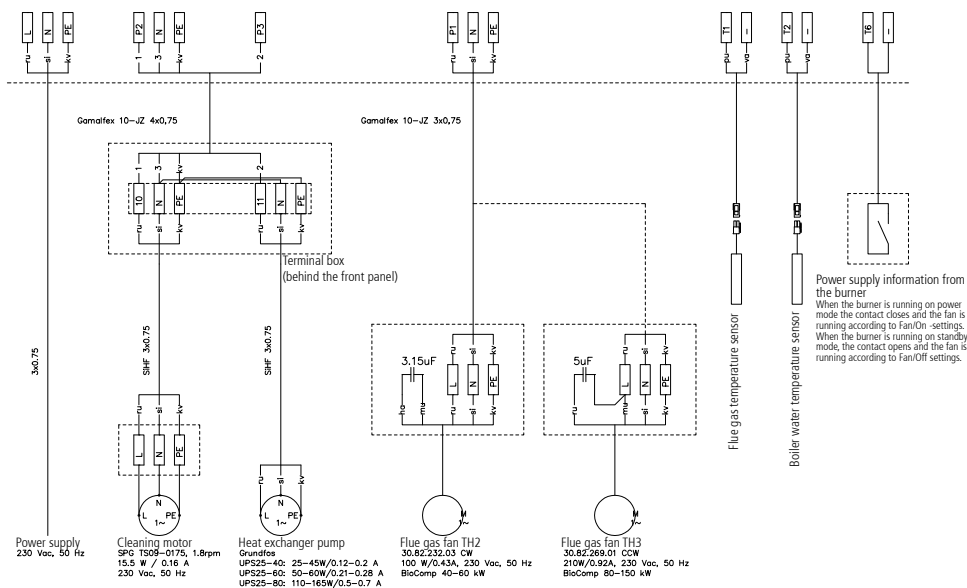

■ Commissioning

1. Connect the controller according to the wiring diagram and switch it on.
2. Go to *Valikot/Menyer/Menus* -> *Huolto/Service*. Choose the language and set the boiler temperature for use if the sensor has been connected.
3. From the main menu set the HE-pump (heat exchanger pump) on.
4. Go to *Menus* -> *Testing* and test the operation of the fan, the pump and the cleaning motor.
5. Go to *Menus* -> *Settings*

Setting	Setting range	Function
Fan /On 50 %	0-100 %	Fan power when the burner is on power mode.
Fan /Off 0 %	0-100 %	Fan power when the burner is on standby/stopped.
Auto sweeping ON Time On 3 min Time Off 4 h	On/Off 0-15 min 0-48 h	Automatic cleaning control. Time of the sweeping period. Delay time between the sweeping periods.

The underpressure of the fire chamber should be between 10-30 Pa when the burner is running. Set the flue gas fan power with the *Fan/On* -setting. When the burner is on standby/stopped the flue gas fan is generally stopped (*Fan/Off* -setting is 0 %).

■ FLUE GAS FAN INSTALLATION

The boiler is supplied with a flue gas fan. Install the fan on suitable side of the boiler (either at the back or on either side instead of the rearmost convector ash hatches).

Delivery includes:

- Flue gas fan (includes capacitor case)
- Flue pipe between the boiler and the fan (including bolts)
- Flue duct extension pipe from fan to chimney

■ Installation



Attach the flue pipe to the boiler with two M10x60 bolts.



Install the flue gas fan to the flue pipe. As a sealant heat resistant mass or sealing strip can be used.



Tighten the fan locking bolt and install the flue duct extension pipe.



Flue gas fan alternative installation position on the side of the boiler. Detach the convection part ash hatch and install the flue gas fan instead.

■ BURNER INSTALLATION

The burner is installed to the burner opening on the side of the boiler. MultiJet burner fits directly to the opening. Burner flanges for BioJet and HakeJet burners, Axon/PX52-pellet burners and oil burners (BioComp 60 only) are available as accessories.

The gap between the burner and the flange must be sealed with heat resistant sealant paste. Burner installation and use according to burner manual.

■ Alternative heating methods

With an oil burner:

An oil or gas burner can be installed into the burner hatch with oil burner accessories. A flange with a brick is available for BioComp 60 kW. The brick has an opening which is 100 mm in diameter.

Note! An oil burner cannot be used simultaneously with a bio burner.

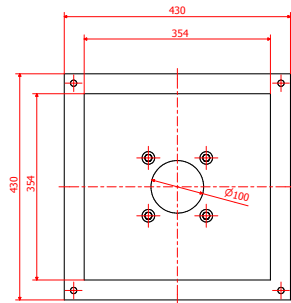

With electricity:

An electric resistance (6 or 9 kW) can be installed into the DN 50 connection on the side of the boiler (drawings on page 6, position 14). The electric resistance is equipped with a regulating/overheating thermostat TY3. More detailed installation instructions are supplied with the thermostat.

Fuse sizes: 6 kW resistance 3x10 A and 9 kW resistance 3x16 A.

Power supply: 400 V, 3~, 50 Hz

NOTE! A safety switch must be installed to the resistance power supply.



1. Installation of the resistance



2. Installation of the thermostat

■ ASH SCREW INSTALLATION

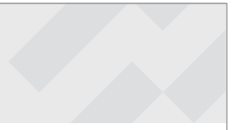

■ COMMISSIONING

Before starting up the heating system the following must be checked:

- the heating network and the boiler are full of water, pressure at least 0,5 bar
- the damper plate is open, if applicable
- the circulation pump is in operation
- the network valves are open
- the combustion air opening is open
- the safety valve has an unobstructed connection to the boiler and is in working order

Start the burner and test its operation as instructed in the burner manual. Make sure that the circulation is working and remove the air that has accumulated in it.

Adjust the flue gas fan power so that the under pressure in the fire chamber is about 10-30 Pa whilst the burner is in operation (check the recommended under pressure from the burner manual). The operating intervals for the ash screw and the automatic convection part cleaning can be adjusted from the Arimatic control centre. Detailed instructions can be found from the control centre user manual.

■ Daily use and maintenance

The daily use of the boiler is dependent on the chosen fuel and the heating requirements. Arimatic control centres control the burning automatically. A prerequisite for a well-operating system is correctly adjusted burning equipment and a sufficient underpressure in the fire chamber.

WARNING: When changing fuel quality, always readjust the system! If necessary, check the suitability of the fuel from the equipment supplier!

NOTE! The maintenance interval of the system depends greatly on the chosen fuel and the correct adjustments of the burner. On the average, the boiler needs to be cleaned every 2-4 weeks.

NOTE! When field biomass or corresponding fuel with higher risk of corrosion is used it is important to ensure that the boiler water temperature is kept high enough to avoid condensation. The return water temperature must not fall below 70 °C. Furthermore, regular checks that no condensation occurs on the fire and convection surfaces must be performed.

It is therefore good to acknowledge that the fuel type has an effect on the boiler's lifetime.

■ MAINTENANCE

■ Maintenance intervals

The following maintenance intervals are indicative and may vary considerably according to the chosen fuel and the heat load. Note that keeping up a very small fire stains the boiler heavily.

At first the maintenance is to be performed more regularly in order to determine the suitable interval for the maintenance. If the fuel quality changes the maintenance interval must be redetermined. During winter the heating requirement is greater than in the summer and therefore the maintenance interval may be shortened compared to summer.

BioComp -series	Interval*)
Sweeping the convection part	Every 4-6 months. Spirals to be removed from the convection part before the sweeping.
Sweeping the fire chamber	Once a year.
Ash removal from the fire chamber	Inspection: 1-2 times a month. If the system has fire chamber ash screws the interval is longer.
Ash removal from under the convection part	Inspection: Once a month. If the system has convection part ash screws the interval is longer.
Visual inspection of the boiler	Inspection: Once a month (pipe connections).
Checking the safety valves	Twice a year.
Checking the tightness of the sealings and hatches (replace if necessary)	Inspection: Once a month.
Burner maintenance according to the burner manual	

*) Using fuel that creates a lot of ash will naturally increase the amount of ash and thus shorten the maintenance interval.

■ MAINTENANCE

■ Ash removal from fire chamber

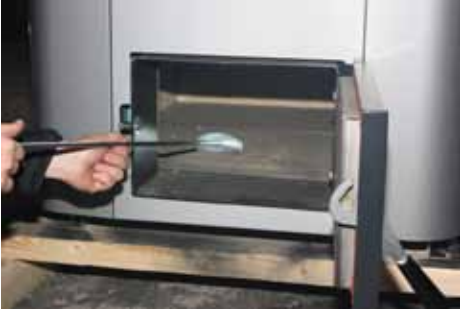

Check the fire chamber ash compartment 1-2 times a month and remove the ash with an ash rake if required. The cleaning interval of the ash compartment depends on the fuel used and the power needed.

If the boiler is equipped with an ash screw the maintenance interval lengthens. However, from time to time the ash from the sides of the ash compartment should be removed.

■ Ash removal from convection part



Check the ash compartments of the convection part once a month and remove the ash with the ash rake if required. The cleaning interval of the ash compartment of the convection part depends on the fuel used and the power needed.

If the boiler is equipped with an ash screw the maintenance interval lengthens.

■ Sweeping the fire chamber



Clean fire chamber surfaces at least once a year. Use bent brush arm and round brush.

■ MAINTENANCE

■ Checking the convection part



The boiler has been equipped with an automatic convector cleaning but the convection part should be checked 2-3 times a year. Open the convector maintenance hatch and lift it aside. **NOTE! The hatch is heavy.**



Check the pipes of the convector and remove fly ash from the surfaces. Test that the spirals move freely in the pipes. If the convection pipes look clean no manual sweeping is required.

■ Sweeping the convection part



If the pipe surfaces look sooty they must be swept manually. Lift the spirals off the convection pipes.

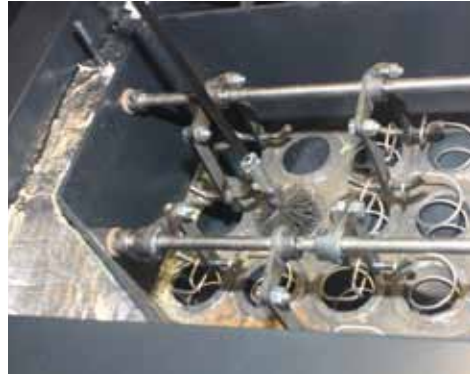

Use straight brush arm and tube brush. Check through every convection pipe. Push the brush all the way through to the ash compartment then it is easy to pull back. Put the spirals back and close the maintenance hatch.

■ WARRANTY, DECOMMISSIONING & CONTACT INFORMATION

■ Warranty

Ariterm Oy grants the equipment it delivers a one-year warranty. The warranty is valid for one year from the commissioning date or at maximum 18 months from the delivery date. The warranty for the pressure vessels manufactured by Ariterm is 5 years from the date of delivery.

Ariterm will deliver new parts to replace the faulty ones and the warranty applies to possible manufacturing and material defects. The warranty does not cover consumables or travel costs.

The warranty does not cover faults caused by incorrect designing, installation, maintenance or operation, or faults caused by off-specification fuel.

Spare part warranty is 12 months. Ariterm will deliver new parts to replace the damaged ones. Unless there are mandatory laws, no other warranty is included in the contract. This paragraph determines exhaustively the Seller's liability for defects and buyer's legal remedies in defect situations.

■ Decommissioning

A worn-out boiler can be scrapped.

■ Contact information

Ariterm Oy

PL 59

FIN- 43101 SAARIJÄRVI

FINLAND

Tel +358 14 426 300

Fax +358 14 422 203

www.ariterm.fi

DECLARATION OF CONFORMITY



VAATIMUSTENMUKAISUUSVAKUUTUS

Valmistaja: ARITERM OY
Osoite: PL 59, 43101 SAARIJÄRVI

Laite: **BioComp 40-150 kW**

- Valmistaja vakuuttaa,
- että tämän yksilön valmistuksessa on huomioitu Euroopan yhteisön neuvoston painelaitedirektiivin (97/23/EY) olennaiset turvallisuusvaatimukset.
 - että vaatimustenmukaisuuden arviointimenettelynä on käytetty H - moduulia. (ilmoitettu laitos 0424)
 - että riskinarviointimenettely on suoritettu konedirektiivin 2006/42/EY mukaisesti (standardi SFS-EN ISO 14121-1).
 - että valmistuksessa on noudatettu oheisten direktiivien vaatimuksia: EMC 2004/108/EY ja pienjännitedirektiivi 2006/95/EY.
 - että seuraavia standardeja on sovellettu: EN 303-5.
 - Toimitukseen ei sisälly varolaitteet.

DECLARATION OF COMFORMITY - MANUFACTURERS DECLARATION

Manufacturer: ARITERM OY
Address: P.O.BOX 59, FIN-43101 SAARIJÄRVI

Equipment: **BioComp 40-150 kW**

- Manufacturer assures,
- that in production of above mentioned example has been observed the essential safety demands of EC council's directive for pressure vessels (97/23/EC).
 - as estimation method of conformity has been used H - module. (notified body 0424).
 - that estimation method of risks has been carried out according to the machinery directive 2006/42/EC (standard SFS-EN ISO 14121-1).
 - that in the production following directives have been applied: EMC 2004/108/EC and low voltage directive (LVD) 2006/95/EC.
 - that the following standards have been applied: EN 303-5.
 - Safety device are not included in the delivery.

FÖRSÄKRAN OM ÖVERENSSTÄMMELSE - TILLVERKAREDEKLARATION

Tillverkare: ARITERM OY
Address: P.O.BOX 59, FIN-43101 SAARIJÄRVI

Apparat: **BioComp 40-150 kW**

- Tillverkare försäkrar,
- att vid tillverkningen av ovan nämnda exempel har man iakttagit väsentliga säkerhetskrav av EG rådets direktiv för tryckkärl (97/23/EG).
 - som värderingsmetod av överensstämmelse har använts H - modul. (notified body 0424).
 - att riskanalysmetod on utförd i enlighet med maskindirektiven 2006/42/EG (standard SFS-EN ISO 14121-1).
 - att vid tillverkningen har man iakttagit följande direktiven: EMC 2004/108/EG och lågspänningsdirektivet 2006/95/EG.
 - att följande harmoniserade standarder har tillämpas: EN 303-5.
 - Säkerhetsutrustning ingår inte i leveransen.

6.10.2011 Ariterm Oy

Petteri Korpioja
Toimitusjohtaja
Managing director
Verkställande direktör

STANDARD DELIVERY



Nro	Component	Prod. code/picture
1	Fire chamber brush	3487
2	Convection pipe sweeping brush	3489
3	Sweeping brush arm	3492
4	Fire chamber brush arm	1356
5	Ash rake	8530
6	Wall holder for cleaning equipment	
7	Flue gas thermometer	5883
8	Temperature/pressure gauge, 1/2"	5885
9	Flue gas fan TH2 (BioComp 60)	20059
	Flue gas fan TH3 (BioComp 80-150)	20060
10	Flue pipe (BioComp 60-80)	A3000-310d
	Flue pipe (BioComp 120-150)	A3000-410d
11	Flue duct extension d139mm (BioComp 60)	TH2-040
	Flue duct extension d159mm (BioComp 80-150)	165089

■ ACCESSORIES

BioComp 40 kW accessories		Product code
	Primary ash screw (incl. motor 0,55 kW)	SBCOM40-230
	Primary ash screw with extra length (incl. motor 0,55 kW)	SBCOM400000

BioComp 60 kW accessories		Product code
	Oil burner kit (incl. adapter flange, d100 mm opening, mountings)	A3060-478
	PX 52 -pellet burner kit (incl. adapter flange, mountings)	A3060-472B
	HakeJet / BioJet -kit (incl. adapter flange, mountings)	A3060-600
	Primary ash screw (incl. motor 0,55 kW)	SBCOM60-230
	Primary ash screw with extra length (incl. motor 0,55 kW)	SBCOM600000

BioComp 80 kW accessories		Product code
	Axon / PX 52 -pellet burner kit (incl. adapter flange, mountings)	A3080-460
	HakeJet / BioJet -kit (incl. adapter flange, mountings)	A3080-600
	Primary ash screw (incl. motor 0,55 kW)	SBCOM80-230
	Primary ash screw with extra length (incl. motor 0,55 kW)	SBCOM800000

BioComp 120 kW accessories		Product code
	HakeJet / BioJet -kit (incl. adapter flange, mountings)	A3120-600
	Primary ash screw (incl. motor 0,55 kW)	SBCOM120-230
	Primary ash screw with extra length (incl. motor 0,55 kW)	SBCOM120000

BioComp 150 kW accessories		Product code
	HakeJet / BioJet -kit (incl. adapter flange, mountings)	A3150-600
	Primary ash screw (incl. motor 0,55 kW)	SBCOM150-230
	Primary ash screw with extra length (incl. motor 0,55 kW)	SBCOM150000

■ ACCESSORIES

Accessory	Prod. code/Picture
Electric resistance 6 kW Thermostat TY3	5210 5212
Electric resistance 9 kW Thermostat TY3	5221 5212
Secondary ash screw x.x m	SBCOM150-260
Ash box	

SPARE PARTS

Prod. code	Cleaning equipment	Boiler
1356	Fire chamber brush arm d10 x M12	40-150 kW
3487	Fire chamber brush	40-150 kW
3492	Sweeping brush arm	40-150 kW
3492	Sweeping brush	40-150 kW
8530	Ash rake	40-150 kW

Prod. code	Electric components	Boiler
5660	Heat exchanger pump Grundfos UPS 25-40	40 - 60 kW
5661	Heat exchanger pump Grundfos UPS 25-60	80 kW
5662	Heat exchanger pump UPS 25-80	120 - 150 kW
14054	Cleaner motor SPG ISG3125	60 - 150 kW
Z20059	Flue gas fan TH2	60 kW
Z20060	Flue gas fan TH3	80 - 150 kW
10536	Ash screw motor 0,55 kW	40 - 150 kW

Prod. code	Heat exchangers	Boiler
3868	Plate heat exchanger 57 kW, E8THx26, 3/4", To be soldered	40 - 60 kW
10243	Plate heat exchanger 75 kW, IC8THx30/1P-SC-S 4x3/4" (20)	80 kW
14721	Plate heat exchanger 120 kW, IC10THx30/1P-SC-S 3x1"(20)	120 kW
14720	Plate heat exchanger 160 kW, IC10THx40/1P-SC-S 4x1"(20)	150 kW
14580	Angle ball valve 3/4"	40 - 80 kW
14702	Angle ball valve 1"	120 - 150 kW

SPARE PARTS

Prod. code	Hatches	Picture code	Boiler
Z10589	Convection part ash hatch		40 - 80 kW
Z13610	Convection part ash hatch		120 - 150 kW
	Convection part hatch BioComp 40	BCOM40-36	40 kW
Z19018	Convection part hatch BioComp 60	BCOM60-36B	60 kW
Z19019	Convection part hatch BioComp 80	BCOM80-36B	80 kW
Z19020	Convection part hatch BioComp 120	BCOM120-36	120 kW
Z19021	Convection part hatch BioComp 150	BCOM150-36A	150 kW
	Maintenance hatch BioComp 40	BCOM40-70	40 kW
	Maintenance hatch BioComp 60	BCOM60-70C	60 kW
	Maintenance hatch BioComp 80	BCOM80-70B	80 kW
	Maintenance hatch BioComp 120	BCOM120-70B	120 kW
	Maintenance hatch BioComp 150	BCOM150-70B	150 kW
	Maintenance hatch reflection plate BioComp 40	BCOM40-74B	40 kW
	Maintenance hatch reflection plate BioComp 60	BCOM60-74B	60 kW
	Maintenance hatch reflection plate BioComp 80	BCOM80-74B	80 kW
	Maintenance hatch reflection plate BioComp 120	BCOM120-74B	120 kW
	Maintenance hatch reflection plate BioComp 150	BCOM150-74B	150 kW

Prod.code	Other	Boiler
13053	Turbulence spring	40 - 80 kW
13141	Turbulence spring	120-150 kW
11015	Oil bronze bearing 12/18x12-24/3 (turbulence mechanism)	40 -150 kW



ARITERM

ARITERM OY | PL 59 (Uuraistentie 1), 43101 Saarijärvi, Finland
Tel +358 14 426 300, fax +358 14 422 203 | www.ariterm.fi

ORGANISATION
CERTIFIED BY

Inspecta

ISO 9001
ISO 14001