



XD-V35 Digital Wireless

Pilot's Handbook

Manuel de pilotage

Pilotenhandbuch

Pilotenhandboek

Manual del Piloto

取扱説明書

Important Safety Instructions

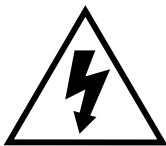

CAUTION
RISK OF ELECTRIC SHOCK DO NOT OPEN



WARNING : TO REDUCE THE RISK OF FIRE OR ELECTRIC SHOCK, DO NOT REMOVE SCREWS.
NO USER-SERVICEABLE PARTS INSIDE. REFER SERVICING TO QUALIFIED SERVICE PERSONNEL.

WARNING : TO REDUCE THE RISK OF FIRE OR ELECTRIC SHOCK, DO NOT EXPOSE THE
APPLIANCE TO RAIN OR MOISTURE.

CERTIFICATION

THIS DEVICE COMPLIES WITH PART 15 OF THE FCC RULES. OPERATION IS SUBJECT TO THE FOLLOWING TWO CONDITIONS: (1) THIS DEVICE MAY NOT CAUSE HARMFUL INTERFERENCE, AND (2) THIS DEVICE MUST ACCEPT ANY INTERFERENCE RECEIVED, INCLUDING INTERFERENCE THAT MAY CAUSE UNDESIRE OPERATION.

Warning: Changes or modifications not expressly approved in writing by Line 6 may void the users authority to operate this equipment.

RF Exposure Statement: This transmitter must not be co-located or operated in conjunction with any other antenna or transmitter.

Note: This equipment has been tested and found to comply with the limits for a Class B digital device, pursuant to part 15 of the FCC Rules. These limits are designed to provide reasonable protection against harmful interference in a residential installation. This equipment generates, uses and can radiate radio frequency energy and, if not installed and used in accordance with the instructions, may cause harmful interference to radio communications. However, there is no guarantee that interference will not occur in a particular installation. If this equipment does cause harmful interference to radio or television reception, which can be determined by turning the equipment off and on, the user is encouraged to try to correct the interference by one or more of the following measures:

- Reorient or relocate the receiving antenna.
- Increase the separation between the equipment and receiver.
- Connect the equipment into an outlet on a circuit different from that to which the receiver is connected.
- Consult the dealer or an experienced radio/TV technician for help.

This Class B digital apparatus complies with Canadian ICES-003. This Category II radio communication device complies with Industry Canada Standard RSS-310. Cet appareil numerique de la classe B est conforme a la norme NMB-003 du Canada. Ce dispositif de radiocommunication de categorie II respecte la norme CNR-310 d'Industrie Canada

The FCC compliance sticker is attached to the THH06 battery compartment.
Remove the THH06 base by unscrewing counter clockwise to see this compliance sticker.



**You should read these Important Safety Instructions.
Keep these instructions in a safe place**



Before using your XD-V35 Digital Wireless System, carefully read the applicable items of these operating instructions and the safety suggestions.

1. Obey all warnings in the XD-V35 manual.
2. Do not perform service operations beyond those described in the XD-V35 Manual. Service is required when the apparatus has been damaged in any way, such as:
 - liquid has been spilled or objects have fallen into the apparatus
 - the unit has been exposed to rain or moisture
 - the unit does not operate normally or changes in performance in a significant way
 - the unit is dropped or the enclosure is damaged
3. Do not place near heat sources, such as radiators, heat registers, or appliances which produce heat.
4. Guard against objects or liquids entering the device. Do not use or place unit near water.
5. Do not step on cords. Do not place items on top of cords so that they are pinched or leaned on. Pay particular attention to the cord at the plug end and the point where it connects to the device.
6. Clean only with a damp cloth.
7. Only use attachments/accessories specified by the manufacturer.
8. Prolonged listening at high volume levels may cause irreparable hearing loss and/or damage. Always be sure to practice "safe listening."

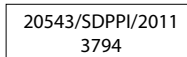
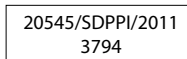
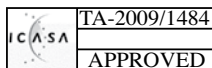

Thank you for your purchase of the XD-V35 wireless microphone system. It is a high quality digital wireless system, in a simple format that is virtually plug-and-play. With its fully digital transmission, the system provides features and benefits that differ in some ways from previous generations of analog wireless, but in most respects you use it just like other wireless systems. By understanding a few simple concepts, you'll be able to achieve superior audio quality, a secure and dropout-free signal, and the ability to use multiple channels of wireless together without interference or other conflicts.

- Digital transmission in the 2.4 GHz band – license-free operation worldwide
- Avoids interference from high-power TV transmitters in the UHF bands
- Digital technology provides the audio response of a cable, without companding – 24-bit digital converters, 118 dBA dynamic range, and 10 Hz – 20 kHz bandwidth
- System latency < 3.5 ms
- Proprietary two-frequency transmission promotes reliable, dropout-free performance
- Compatible with existing WiFi installations
- Fast setup: gain, squelch, or level adjustments not required
- 6 channels that work together simultaneously
- 275 foot (83 meter) range
- Transmitter life > 8 hours on two AA alkaline batteries
- Battery level and RF LED meters
- Table top receiver with internal antenna
- XLR and ¼" TRS output connectors
- Designed for compatibility with previous XD-V30 systems

RECOMMENDATIONS FOR BEST PERFORMANCE

- Maintain a clear line of sight between the transmitter and receiver's internal antennas. Typically the receiver should be placed at table top or higher level. Avoid placing the receiver in the bottom of the rack or behind walls and obstructions.
- When transmitters are used at a greater distance, place receivers closer to them and use XLR mic (or ¼") cables to connect to the audio system.
- Avoid placing the receiver in close proximity to RF generating equipment including computers, wireless access points, in ear monitor transmitters and microwave ovens.
- Avoid blocking antennas in the transmitters. Do not "cup" the bottom of the handheld transmitter. Avoid placing the bodypack transmitter in pockets.

SUPPLIED COMPONENTS

XD-V35 Receiver: receiver; 9V / 0.5A external universal power supply; user's manual.

THH06 Handheld Microphone: transmitter; two (2) AA alkaline batteries; mic stand clip.

or

TBP06 Bodypack Transmitter: transmitter; two (2) AA alkaline batteries; unidirectional lavalier microphone with windscreen and clip.

XD-V35 DIGITAL WIRELESS QUICK SETUP

Receiver

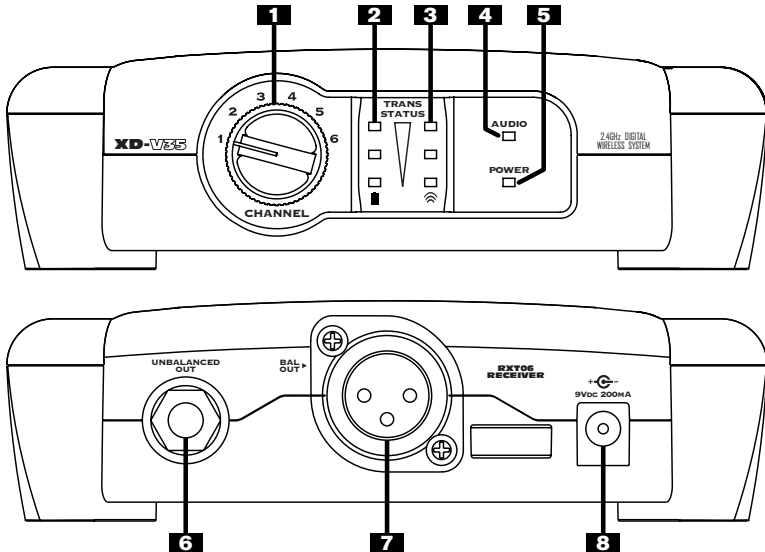

1. **6-Position Channel Select Knob**
2. **Battery Level Indicator LEDs** – Lights green, with all lit indicating full transmitter battery; bottom LED turns red when 1 hour remains, and flashes red when less than 40 minutes remain.
3. **Transmitter Signal Level Indicator LEDs** – RF lights green to indicate transmitter signal strength/quality; with transmitter off, red lights indicate interference on that channel.
4. **Audio LED** – Green when audio signal present.
5. **Power LED** – Blue when on.
6. **Unbalanced 1/4-Inch Audio Output Connector**
7. **Balanced XLR Audio Output**
8. **9VDC Power Input Connector** – Plug the power supply cable into the receiver and AC power; receiver will turn on. Turn the rotating **Channel Select** knob to the desired channel (must match transmitter channel). Connect with an audio cable to a mixer or similar. The receiver is ready to use.

Note: The receiver antenna is internal.

Bodypack Transmitter

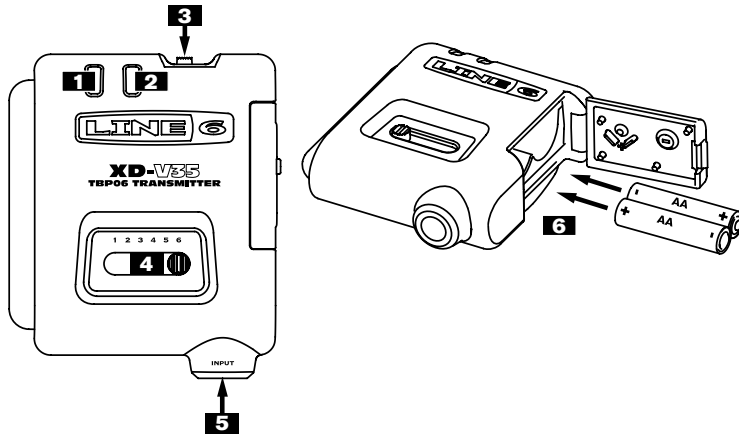

1. **Audio LED** – Green when audio signal present
2. **Battery Level LED** – Blue with good level, red when low, flashing red when less than 40 minutes remain
3. **On / Off Slide Switch**
4. **Channel Select Slide Switch**
5. **Quarter-Inch (1/4") TRS Input Connector**
6. **Battery Door** Slide switch and hinged door. Open the battery door on the side of the bodypack and insert two AA batteries. Slide the **On/Off** switch to turn on. Slide the **Channel Select** button to select; match the channel number with the receiver channel. The transmitter is ready to use.

Note: The bodypack transmitter features a belt clip to secure it to a belt or other clothing.

Handheld Transmitter

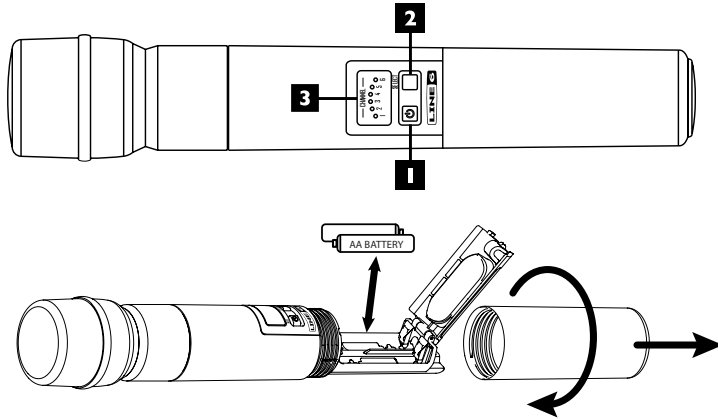

1. **Power Button** – Press briefly to turn on; press and hold for two seconds to turn off
2. **Channel Select Button** – Channels 1 – 6
3. **Channel LEDs** – Lights blue to show current active transmission channel; Channel 6 LED illuminates red when battery life is low, and blinks red when less than 40 minutes remain. Unscrew the transmitter base and insert two AA batteries. Push the On button to turn on. Press the **Channel Select** button to set the channel, indicated by LED position on display; match the channel number with the receiver channel. The transmitter is ready to use.

XD-V35 RECEIVER DETAILED SETUP

The receiver is quite simple to set up. This section adds a few useful details.

- When used stand-alone, position the receiver on a surface that provides line of sight (or at least near line of sight) with the location where the transmitters will be used. This will help maximize the range.
- Connect the provided DC-1G power supply to the 9VDC 200mA connector on the rear panel; to secure, press a loop of the cable through the cable holder located to the left of the connector to prevent accidental disconnection. Plug the power supply into an available AC outlet that provides voltage from 90 – 240 VAC at 50 or 60 Hz.
- The blue **Power** LED on the front panel will light and the receiver is on.
- Turn the **Channel Select** knob to point to channel 1 through 6. The channel number on the receiver and its associated transmitter must match. When using multiple receivers, set each one to a different channel number.
- With the associated transmitter turned on, you will see – depending on the distance between the transmitter and receiver – all three or the bottom one or two RF LEDs lit green, on the right side of the **Trans Status** window.
- Depending on the condition of the transmitter batteries, you will see all three or the bottom one or two battery status LEDs lit green, on the left side of the **Trans Status** window. If the battery level is low, the bottom LED will turn red, and it will flash red when 40 minutes or less remain.
- When you speak or sing into the microphone, the green **Audio** LED will light.
- Connect to the audio system using the rear-panel **Balanced XLR Audio Output** or **Unbalanced 1/4-Inch Audio Output**. **Note**, the signal output from either of these connectors is mic level, and

the receiver has no gain or attenuation controls. ⚠ Do not use TRS connectors with the XD-V35 Receiver as the Ring portion of the connector is used for firmware updates and may cause computer generated noise in your audio outputs.

Note: When the associated transmitter is off, and moderate to strong interfering frequencies not coming from a Line 6 transmitter are present on the selected receiver channel, one or more of the RF LEDs on the right side of **Trans Status** will turn red. Higher levels of interference will light more red LEDs. Use in high interference conditions will result in reduced range for the system. Either move the receiver away from the source of the interference – such as a nearby WiFi modem or computer with a WiFi transceiver – or select another channel not showing interference.

THH06 HANDHELD TRANSMITTER DETAILED SETUP

- Twist the bottom section of the THH06 transmitter counterclockwise, unscrew, and remove it. Lightly pull the battery cover tab down with a thumbnail, and open the cover by pulling back; it is hinged at the base of the transmitter.
- Insert two AA batteries, noting the polarity markings shown in the battery compartment. Use alkaline batteries, or rechargeable NiMH batteries in the 2400 – 2800 mAh range. Close the battery cover and replace the bottom section of the transmitter.
- Press and briefly hold the left button below the **Channel** display to turn on. A small blue LED will light above the currently selected channel.
- Press the right **Select** button to change to the next channel; the blue LED above the number will light. Each press of the button will go to the next channel. The channel is selected and active immediately. **Note**, the transmitter buttons are recessed to prevent accidental activation, so press them down firmly below the recessed surface, until you feel a click.
- When the transmitter is on the same channel number as the receiver, the receiver **Trans Status** LEDs will light green, and when you speak in the mic the receiver **Audio** LED will light green.

Note: When the transmitter battery level is low, the LED over the number 6 on the display will light red, and it will flash red when less than 40 minutes remain. Line 6 transmitter battery-life meters are calibrated for use with alkaline batteries, so when NiMH rechargeable batteries are used the remaining life will not be as accurate – however, the basic indication is to insert fresh batteries soon after the LED shows red. Carbon-zinc batteries are not recommended.

TBP06 BELTPACK TRANSMITTER DETAILED SETUP

- With a thumbnail, slide down the latch on the battery door located on the right side of the transmitter.
- Open the hinged door and insert two AA batteries, noting the polarity markings shown on the top plate of the battery compartment. Use alkaline batteries, or rechargeable NiMH batteries in the 2400 – 2800 mAh range. Close the battery cover and slide the latch up with your thumbnail to lock.
- Slide the switch on the top of the transmitter to ON; the LED marked **Batt** (battery) will light blue. **Note**, When the transmitter battery level is low, the **Batt** LED will light red, and it will flash red when less than 40 minutes remain.
- On the face of the transmitter, the **Channel** select provides a metal slide switch to set a channel from 1 to 6. Slide the metal button to the desired channel number; it has detents so it will stop in the correct place. The channel is selected and active immediately.
- Connect the lavalier microphone to the 1/4" TRS (tip-ring-sleeve) jack on the bottom of the transmitter. When you speak in the mic, the **Audio** LED will light.
- When the transmitter is on the same channel number as the receiver, the receiver **Trans**

Status LEDs will light green, and when you speak in the mic the receiver **Audio** LED will light green.

CONNECTING THE XD-V35 RECEIVER

The receiver features a balanced XLR and unbalanced (tip-sleeve) quarter-inch connector. To connect to a mixing board or powered mixer, use a microphone cable between the receiver output and the mixer's mic-level input – in the same way as you would connect a wired microphone. The output of the XD-V35 receiver is virtually identical to that of the microphone on the transmitter, or other standard wired mic.

To connect to an instrument amplifier or other audio equipment with a quarter-inch connector such as a signal processor or effects unit, use a 1/4" to 1/4" instrument cable. This output is also mic level.

Microphone Usage Tips

Try to maintain a constant distance and relationship between the user's mouth and the microphone. In live theatre this is often done by placing a small mic in the hairline toward the front side of the head or right above the ear. With mic placement on the collar or shoulder area, changes in level can occur as the user's head turns; experiment with the location of the mic to minimize this effect. Mic placement in the center of the chest can help with the level changes, but is farther from the voice and quite shielded from the direct energy of the voice, so typically provides a hollow midrange or "chest" sound to the voice.

The V35 Belt Pack transmitter includes a built in roll-off filter.

Walk-Testing the Performance Area

When first setting up a wireless system in a new location, it is good practice to position the receivers where they will remain during the event, and then walk the entire performing area with the audio system on and the transmitter active. Talk and listen for signal dropouts or other problems, and note where they are with respect to your receiver placement.

If possible, reposition the receiver to obtain better coverage and improve or eliminate areas with lower signal strength – by improving line-of-sight to the transmitter.

APPENDICES

Troubleshooting

Problem	Solution
No Audio	Transmitter off or battery out of power Batteries put into transmitter out of polarity Transmitter and receiver on different channels Receiver off / unplugged or not connected
Can't Turn Off Transmitter Change Channels	Transmitter in locked mode (THH06 handheld only)
Loss of Signal Dropouts Shorter Range	Distance between transmitter and receiver is too great. Other transmitting or RF devices are too close to the receivers. Receiver not in line-of-sight with transmitter Interference on channel – change channels Another Line 6 transmitter is turned on and set to the same channel

Setting THH06 and TBP06 Transmitters to XD-V30 Compatibility Mode

The XD-V35 system ships set to the new dual frequency RF2 mode. To use an XD-V35 version transmitter with an earlier generation XD-V30 receiver (RF1 mode), you must change the transmitter from RF2 mode to RF1 mode. The method differs slightly between the handheld and beltpack.

THH06 Handheld Transmitter

- Turn the transmitter off.
- Press and hold the channel SELECT button.
- While holding the SELECT button, press and hold the power ON button.
- The blue LED over channel 1 will flash three times to indicate that the transmitter is in the RF1 mode.
- To revert to the RF2 mode, repeat the above steps; the blue LED over channel 2 will flash three times when the transmitter is in this mode.

TBP06 Beltpack Transmitter

- With transmitter off, set the Channel Select slide switch to channel 6.
- Turn on the transmitter.
- Wait for the blue LED to flash followed by a green LED flash.
- Immediately slide the Channel Select switch completely left to channel 1.
- Quickly slide the Channel Select switch completely right to channel 6.
- This process must be completed within three seconds of turning on the transmitter.
- The blue LED will flash once to indicate that the transmitter is now in the RF1 transmission mode. To revert to RF2 transmission mode, repeat the above steps; the blue LED will flash twice when the transmitter is in this mode.

XD-V35 Digital Wireless System Specifications

System

Frequency Band	2.4GHz ISM Band
Compatible Channels	6
Spatial Diversity with Digital Buffering	Yes
Frequency Diversity	Yes (2 Frequencies per channel)
Comander-Free Design	Yes
Frequency Response THD %	10 Hz (-0.5 dB) - 20kHz (-2.5 dB) 0.03% typical
System Latency	< 3.5 ms (audio input to output)
Operating Temp Range	0 – 50 degrees C
Range	up to 275 feet (83 meters) Actual range will depend on nearby RF interference sources including line of sight obstacles

Receiver

RF Signal Strength Indicator	3-Segment LED
Battery Level Indicator	3-Segment LED
Audio Presence LED	Yes
Squelch & Pad adjustments	None required
Receiver Antennas	Internal
Receiver Format	Table Top
Receiver Power Requirements	9Vdc 200mA
Output Impedance	XLR: 150 Ohms Balanced / 1/4": 1 kOhm Unbalanced 95 dBm
Sensitivity Image Rejection	56 dB

Transmitters

Transmitter RF Output Power	10 mW
Battery Life	8 hours
Batteries	2 x AA Alkaline
Battery Level Display	Low Battery LED
Dynamic Range	
THH06 Handheld	>115 dB
TBP06 Beltpack	>118 dB
TBP06 Maximum Audio Input Level	6.5 Vpp
TBP06 Beltpack Input Impedance	1.3 M Ohms
TBP06 Beltpack Supplied Bias Voltage	5 VDC

Pinout To TBP06 Beltpack 1/4" TRS Connector

- Tip = Signal
- Ring = Bias Voltage, 5 VDC
- Sleeve = Ground

