

Digital Practice Drum

User's Manual



Congratulations

Thank you for purchasing this digital Practice drum . The drum has been developed to act and play like a acoustic drum set but with greater ease and function. Before you use the instrument, we recommend you to read through this manual.

Taking Care of Your Digital Drum Set

Location

- Do not expose the unit to the following conditions to avoid deformation, discoloration, or more serious damage.
- Direct sunlight.
- High temperature (near a heat source, or in a car during the day time).
- Excessive humidity.
- Excessive dust.
- Strong vibration.

Power Supply

- Make sure to use the suitable AC adaptor, and also make sure the AC outlet voltage in your country matches the input voltage specified on the AC adaptor's label.
- Turn the power switch OFF when the instrument is not in use.
- An AC adaptor should be unplugged from the AC outlet if the instrument is not to be used for an extended period of time.
- Unplug the AC adaptor during electric storms.
- Avoid plugging the AC adaptor into the same AC outlet as appliance with high power consumption, such as electric heaters or ovens. Also avoid using multi-plug adaptors since these can result in reducing the sound quality, operation errors, and possibly damage.

Turn Power OFF When Making Connections

- To avoid damages, turn off the power switches before you disconnect the related devices from the instrument.

Handling and Transport

- Never apply excessive force to the controls, connectors or other parts of the instrument.
Always unplug cables by gripping the plug firmly, but not pulling on the cable.
- Disconnect all cables before moving the instrument.
- Physical shocks caused by dropping, bumping, or placing heavy objects on the instrument can result in scratches and more serious damage.

Electrical Interference

- This instrument contains digital circuitry and may cause interference if placed too close to radio or television receivers. If this occurs, move the instrument further away from the affected equipment.

Content

Summary.....	4
Main Feature.....	4
Setting Up.....	5
Power Supply.....	5
Using Headphones.....	5
Stand setup.....	6
Cymbal setup.....	7
Panel.....	8
Top Panel.....	8
Side Panel.....	9
Rear Panel.....	9
LCD Display.....	10
Playing The drum.....	11
Changing the Parameters.....	11
Beat.....	11
Rhythm.....	11
Click Sound.....	12
Click Volume.....	12
Change The Pad Sound.....	12
Training Mode.....	13
Beat Check.....	13
Balance.....	13
Pattern.....	14
Follow Me.....	15
Gradual Up/Down.....	15
Count.....	16
Timer.....	17
Game.....	18
Tempo/TAP.....	19
Record.....	19
Start Recording.....	19
Stop Recording.....	19
Playback.....	19
Parameter Save And Factory Set.....	20
Parameter Save.....	20
Factory Setting.....	20
Appendix.....	21
Pad Sound List.....	21
Game Demo List.....	22

Summary

The digital drum is an easy-to-use digital drum with advanced functions especially in self-training. The training function including: beat check balance gradual up/down etc.. and it is a unique set of exercises specifically designed to help build speed, accuracy, stamina, and better timing skills. Moreover, the GAME function allows users to learn and play with a rhythm by following the dropping bars on the LCD. The high-quality sounds and the multi_function display, is also suitable for the professional and amateur drummer.

Main Feature

- 65 Pad Sounds and 6 Metronome Sounds
- 24 Rhythm Types
- Beat Check Training
- Pattern Training
- Stroke Balance Training
- Follow Me Training for building sense of timing
- Gradual Up/down Training for Developing Your Tempo Feel
- Count Training
- 60 Games for Practising The Built-in Patterns
- Record and Playback
- Phone Output Supports a Stereo Headphone As Output Device
- Additional Kick and Hi-hat Can Be Connected To Assembled As a Basic Drum Kit

SETTING UP

Power Supply

Your Digital Drum will run either on batteries or power adaptor. Follow the instructions below according to the power source you intend to use.

Using an AC-Adaptor

Connect the power adaptor to the DC in jack located on the rear panel of the unit, and plug the AC power adaptor into an AC power outlet.

** Do not use adaptors other than the one specified. The technical specification of the adaptor is 9V DC output, 500mA, centre positive type.*

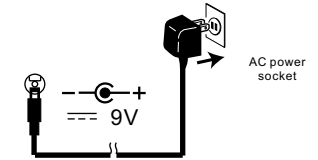

Using Batteries

1. Press down and slide off the lid of the battery compartment (located on the bottom of the unit)

2. connect the snap cord to the battery, and place it inside the battery compartment.

** Verify the battery's polarity (+ versus -)*

3. Securely close the battery cover.

** Do not let the snap cord get caught in the battery compartment lid.*

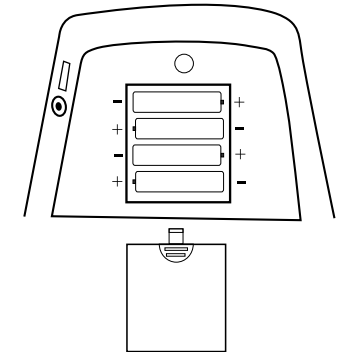

When to Change the Battery

The battery LOW indicator (⚡) at the lower right of the display begins to flash when the battery power drops. Insufficient battery power lowers the volume level of the mini speaker and causes unstable operation. Replace the battery as soon as possible.

** We recommend replacement with alkaline batteries.*

** The estimated life span of the batteries is 4 hour*

Using Headphones

An optional set of stereo headphones can be connected to the Headphones jack located on the rear panel. When a pair of headphones is connected to the jack, the internal speakers of the unit will switch off automatically, perfect for private practice or late night playing. If you want to use an external sound system, the headphone jack can also be used to connect the digital drum to a stereo system or mixing console.

** Turn the power OFF on all equipment before making any connections.*

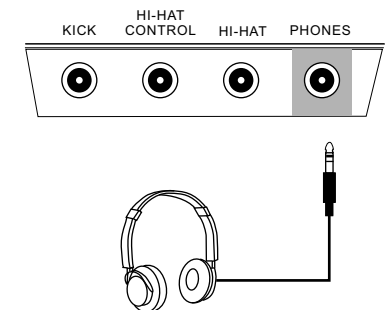

Stand setup

Mounting the digital drum on the stand

1. First, open the tripod so the legs are spaced at least 30cm apart.

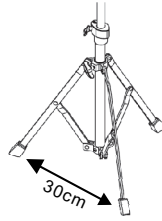

2. Attach the wing screw and washer in the order shown in the figure.

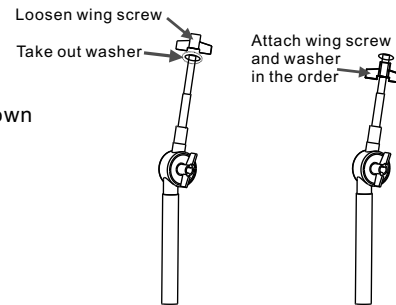

3. Attach the pad
Turn the pad until the screw is just about all the way in; then adjust the angle of the pad and tighten the wing screw from side the stand.

* Do not forcefully try to turn the pad after the screw is already all the way in. doing so may damage the stand's screw

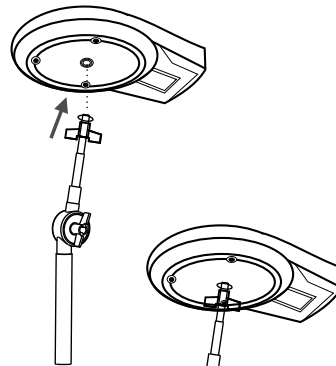

4. Mounting the digital drum on the tripod.

Precautions When Folding the Tripod
when folding the digital drum tripod legs to store the unit, be cautious not to get your fingers pinched while handling the stand.

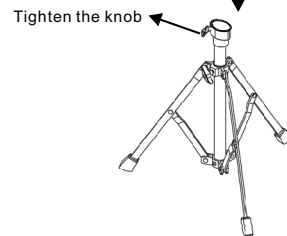

Cymbal Setup

Setup cymbal on the tripod.

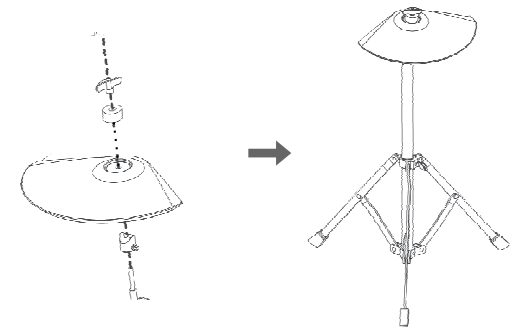

Using an optional cymbal cable you can connect cymbal pads to the HI-HAT in jack.

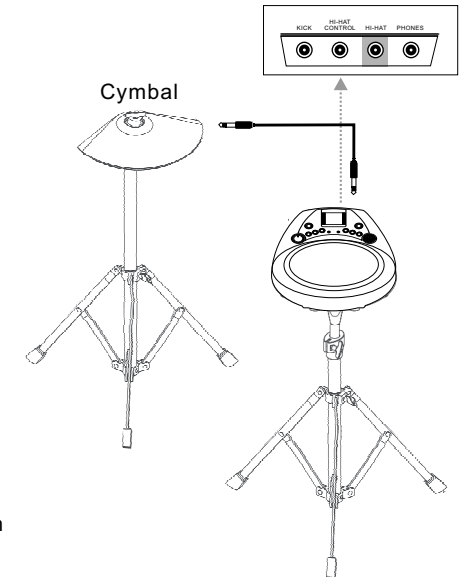

Using an optional kick cable of kick you can connect KICK pads to the KICK in jack.

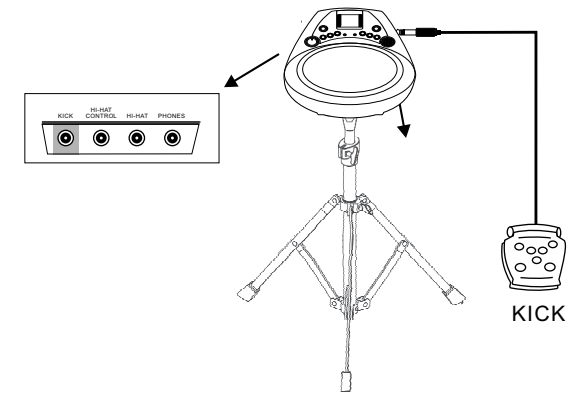

Top Panel

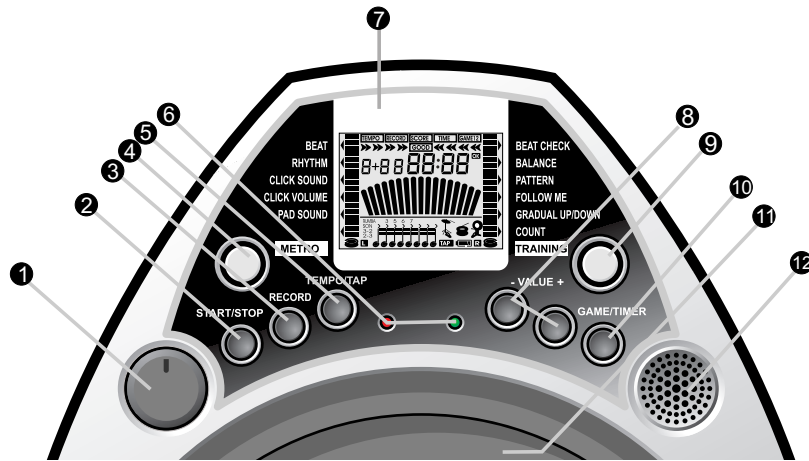

Fig.1

- 1 Volume knob**
Adjust the sound level.
- 2 [START/STOP] button**
Start or stop the metronome.
- 3 [RECORD] button**
Enter record mode.
- 4 [METRO] button**
Use this button to select pad sounds and the item of metronome setting.
- 5 [TEMPO/TAP] button**
Adjust the tempo (from 30 to 240), Hold and press this button to enter TAP mode.
- 6 Beat indicator**
Flashes in quarter note timing. Red indicator flashes on accent beats.
- 7 LCD display**
Display the parameter for current operating item.
- 8 [VALUE +] & [VALUE -] button**
Change the values of each parameter.
- 9 [TRAINING] button**
Select the training mode.
- 10 [GAME/TIMER] button**
Enter game mode, Hold and press this button to enter TIMER mode.
- 11 Drumpad**
- 12 Mini speaker**
Only the metronome sound is played from here. Not including the stroken sound.

Side Panel

- 1 DC input**
Connect DC 9v.
- 2 Power Switch**
This switch turns the power on/off.

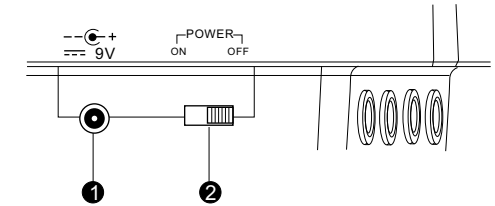

Fig.2

Rear Panel

- 1 Kick jack**
Connect bass drum controller for mono input.
- 2 HI-HAT Control jack**
Connect hi-hat controller for mono input.
- 3 HI-HAT jack**
Connect hi-hat, crash or cymbal pads for stereo input.
- 4 Phone output**
The phone output supports a stereo headphone and amplifier as output device.

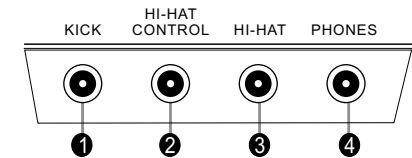

Fig.3

LCD Display

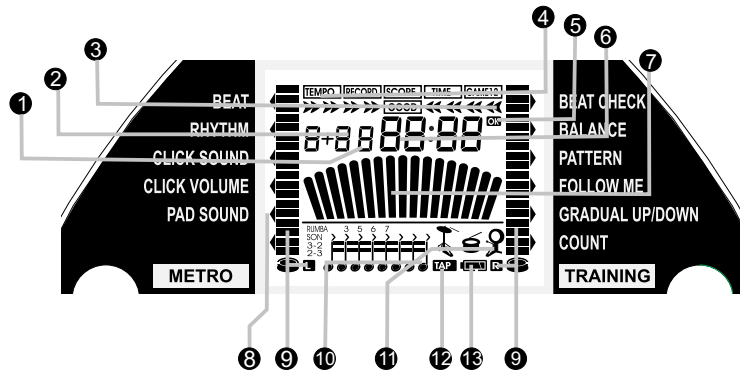

Fig. 4

- ① **Beat count**
Range: 1~9.
- ② **Beat**
- ③ **Time check**
- ④ **Tempo, record ,score, timer, game mode indicator**
- ⑤ **Game ok flag**
In game2 mode, when the score is more than 60, the flag will be lightened.
- ⑥ **Parameter display**
Display the parameter for tempo, game practicing score and etc.
- ⑦ **Metronome needle**
- ⑧ **Metronome item indicator**
- ⑨ **Game note display**
Display the left and right hand notes of current playing song.
- ⑩ **Rhythm type**
- ⑪ **Extend pad jack indicator**
- ⑫ **Tap icon**
- ⑬ **Battery low indicator**

PLAYING THE DRUM

Changing the Parameters

Press **[METRO]** button to select the parameter, including Beat, Rhythm, Click Sound, Click Volume, Pad Sound and Metronome.

Press the **[+]** or **[-]** to adjust the parameter for each item. The Arrow on the LCD points to the selected parameter.

Press **[START/STOP]** button to turn the metronome on and off.

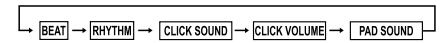
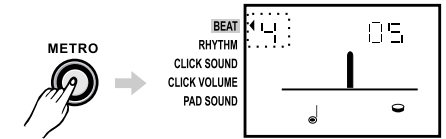

Beat

Below is a list of beats to be chosen from the drum.

0~9, 2+3, 3+2, 3+4, 4+3, 4+5, 5+4, 5+6, 6+5, 6+7, 7+6, 7+8, 8+7, 8+9, 9+8

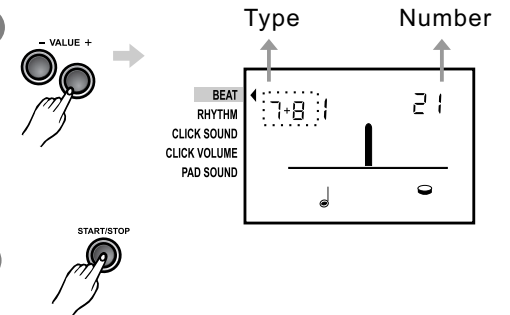

Rhythm

24 rhythm styles at all.

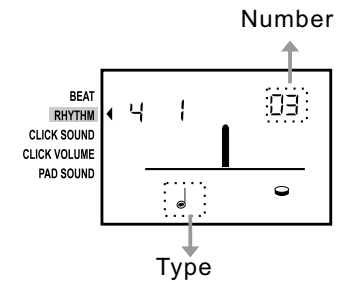

Click Sound

There are 6 clicking sounds in total:

NO.	NAME
1	METRONOME
2	CLAVES
3	STICKS
4	COWBELL
5	VOICE COUNT
6	ELECTRONIC

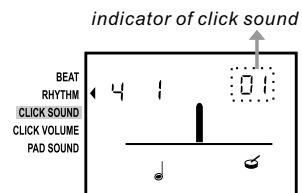

Click Volume

It provides 0~4 level for volume adjustment.

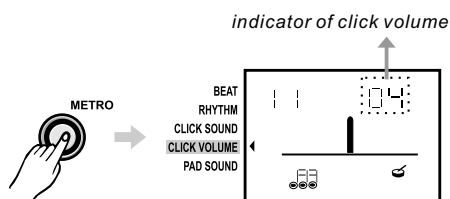

Change The Pad Sound

Press the [METRO] button to enter pad sound selection mode. 65 pad sounds in total. Press the [+] or [-] to select the sound. (See Appendix).

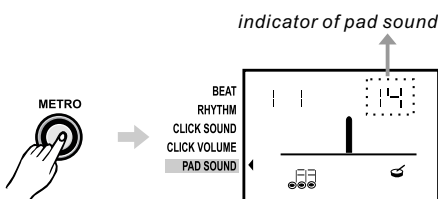

* Be note that do not play the metronome at a very high tempo and hit the pad quickly using a stringed sound simultaneously, it may influence the metronome indicator run smoothly.

TRAINING MODE

This function is a unique set of exercises specifically designed to help build speed, accuracy, stamina and better timing skills.

Changing the Exercise Function

Press [TRAINING] button to select the desired function.

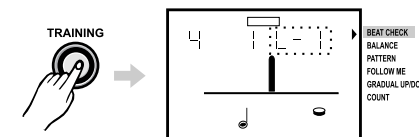

Press the [+] or [-] to select the exercise item. The arrow on the LCD points to the selected function.

Press the [START/STOP] button to start/stop the exercise.

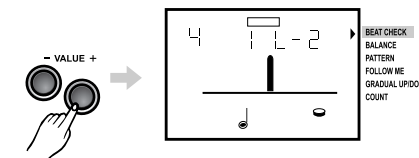

Beat Check

The beat check mode setting is used with all other training modes. Regardless of how the metro sound is played in other training mode, the rhythm will be checked according to the beat check setting. The best check result appears on the display.



Beat Check Level

L-1	Quarter note (relatively easier timing)
L-2	Quarter note (more exact timing)
L-3	8 th -note (relatively easier timing)
L-4	8 th -note (more exact timing)
L-5	16 th -note (relatively easier timing)
L-6	16 th -note (more exact timing)
L-7	16 th -note triplets (relatively easier timing)
L-8	16 th -note triplets (more exact timing)

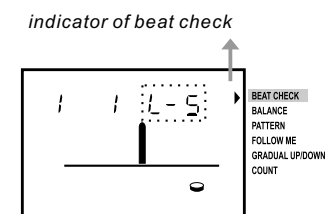

Balance

This function checks the differences in playing dynamics between the left and right hands (or one hand).

Press the [START/STOP] button to start/stop the exercise.

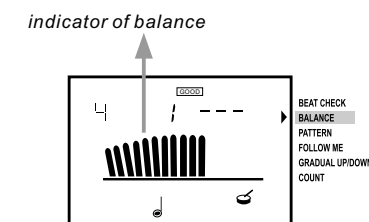

Pattern

This function is based on a traditional warm up exercise and also helps in learning various rhythmic type. The metronome plays through a series of note intervals or beat divisions. Each one is played for 2 measures before moving on to the next interval level.

Press the **[+]** or **[-]** to select the type for this exercise.

Press the **[START/STOP]** button to start/stop the exercise.

Pattern type:

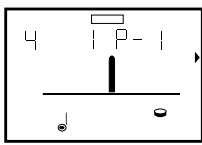
BEAT CHECK
BALANCE
PATTERN
FOLLOW ME
GRADUAL UP/DOWN
COUNT



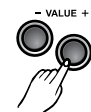
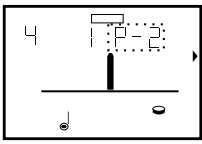

BEAT CHECK
BALANCE
PATTERN
FOLLOW ME
GRADUAL UP/DOWN
COUNT

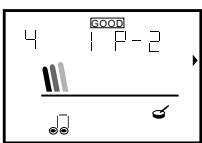

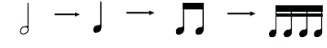

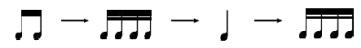
BEAT CHECK
BALANCE
PATTERN
FOLLOW ME
GRADUAL UP/DOWN
COUNT

P-1 

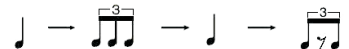
P-2 

P-3 

P-4 

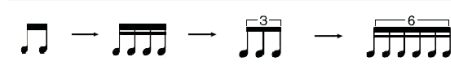
P-5 

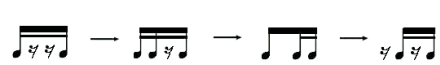
P-6 

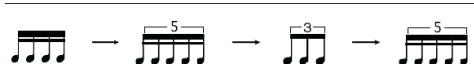
P-7 

P-8 

The accuracy result is displayed on LCD. (show picture)

Follow Me

In this mode, the metronome sound alternately switches between normal and mute volume levels according to the selection. This cycle repeats until you press the **[START/STOP]** button to stop the exercise.

It has 4 types to choose:

- F-1: 1 measure cycle (that means one measure play in normal volume & one measure play in mute status)
- F-2: 2 measure cycle
- F-3: 4 measure cycle
- F-4: 8 measure cycle

Press the **[+]** or **[-]** to select the type for this exercise.

Press the **[START/STOP]** button to start/stop the exercise.

Gradual Up/down

This function is designed to improve your playing stamina by increasing and then decreasing the metronome speed. The tempo will increase until it reaches the max tempo you set. Then it will decrease until it reaches the original tempo. This repeats until you press the **[START/STOP]** button. You are allowed to set the original tempo before you start to play. Meanwhile, the max tempo can be set when it reaches the tempo you want by press **[TEMPO]** button in process of exercise.

It has 5 tempo variation type to choose:

- G-1 The tempo will increase or decrease by 1BPM on every beat
- G-2 The tempo will increase or decrease by 1BPM every two beat
- G-3 The tempo will increase or decrease by 2BPM every 8 measures
- G-4 The tempo will increase or decrease by 5BPM every 8 measures
- G-5 If you play correctly for eight measures, the drum will acknowledge this and advance 5 BPM faster.

What is BPM?

BPM is an abbreviation for "beats per minute" (number of quarter-note beats in a one-minute period). Also means "tempo".

Press the **[+]** or **[-]** to select the type for this exercise.

Press the **[START/STOP]** button to start/stop the exercise.

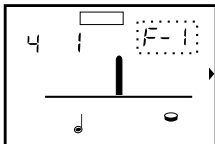
BEAT CHECK
BALANCE
PATTERN
FOLLOW ME
GRADUAL UP/DOWN
COUNT

BEAT CHECK
BALANCE
PATTERN
FOLLOW ME
GRADUAL UP/DOWN
COUNT

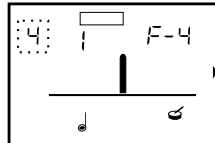
BEAT CHECK
BALANCE
PATTERN
FOLLOW ME
GRADUAL UP/DOWN
COUNT

BEAT CHECK
BALANCE
PATTERN
FOLLOW ME
GRADUAL UP/DOWN
COUNT

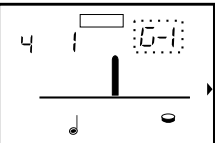
BEAT CHECK
BALANCE
PATTERN
FOLLOW ME
GRADUAL UP/DOWN
COUNT

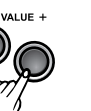
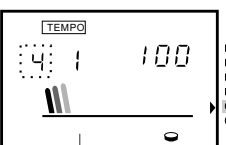
Count

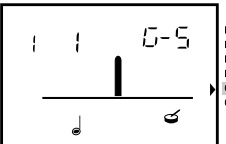
This function helps you to count the amount of pad hitting within the fixed time; And it also offer you to count the time you spend for finishing the fix hitting amount .

The fixed time can be chosen with **[+][-]** includes: 15S,30S,60S.

The fixed hitting amount can be chosen with **[+][-]** includes: 200,500,1000

Press **[START/STOP]** to start to exercise.

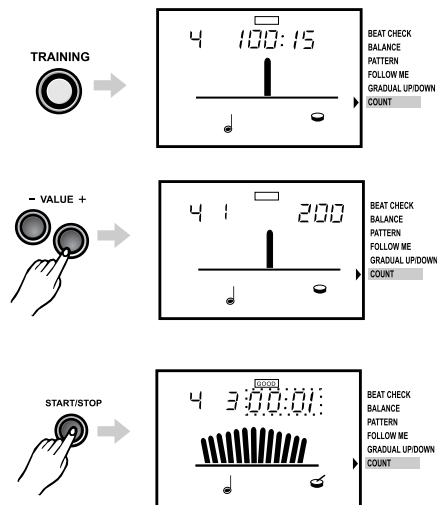

In fixed time accounting mode. After a one-measure count-in, the counting of pad hitting will be displayed on LCD in real-time. The time left will be shown in the shape of metronome needle. When it reaches the fixed time, the counting will be stopped automatically and the pad hitting value flashes.

In fixed hitting counting mode. After a one-measure count-in, the time you spend will be displayed on LCD in real time. The hitting left will be shown in the shape of metronome needle.

When it reaches the fixed hitting amount, the time counting will be stopped automatically and the accounting value flashes. If the time you spend is more than 60 minutes, it will exit accounting mode.

When the LCD flashes accounting value, press **[+][-]** to exit this mode and press **[start/stop]** to replay.

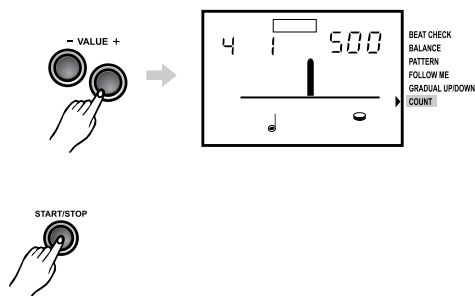

Timer

This timer can be set from 1 to 60 minutes, letting you practice for the period of time you determine.

Briefly hold down the **[GAME]** button 3 seconds, enter the timer mode. The timer indicator lightened.

Press **[+]** or **[-]** button to set the time.

Press **[START/STOP]** button to start the timer.

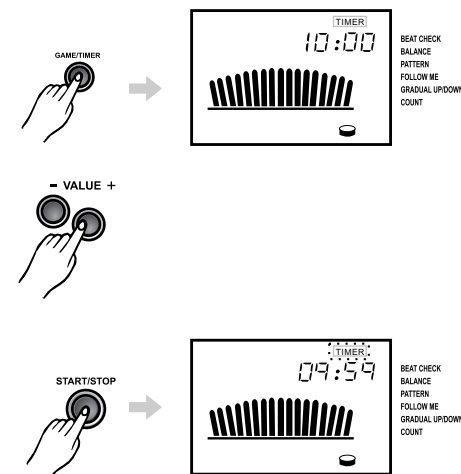

Game

The game feature let you learn and play a rhythm by following the dropping bars on the left or right of the LCD. When the dropping bars reaches to the pad icon which is at the bottom of the LCD, strike the pads.
The digital drum have 60 rhythms, the grade is from easy to hard.

It provide 3 game modes to practise: GAME, GAME 1, GAME 2.

Press **[GAME]** button for the first time to enter the GAME mode, the drum track of the rhythm is turned on, and it won't score the note you play.

Press **[GAME]** button for the second time to enter the GAME 1 mode, the drum track of the rhythm is mute, it will score your practise.

Press **[GAME]** button for the third time to enter the GAME 2 mode, the drum track of the rhythm is mute, it will score your practise., if the score is more than 60, the OK icon will appear on the LCD, then you can continue to play the next rhythm. This mode will help you know well about your progress.

Press **[METRO]**, **[TRAINING]**, **[RECORD]** button to exit the GAME mode.

Press **[GAME]** button repeatedly to enter the corresponding GAME mode in turn.

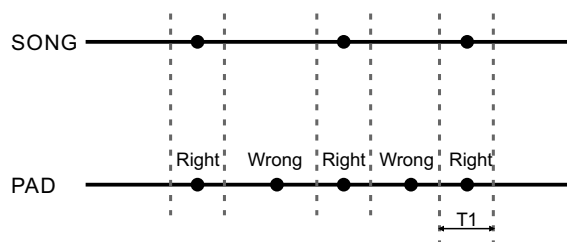
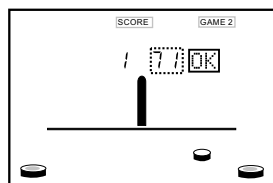
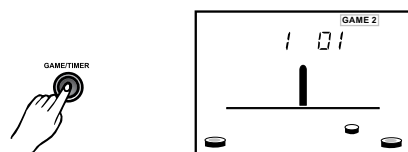
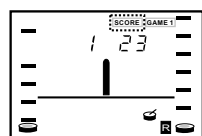
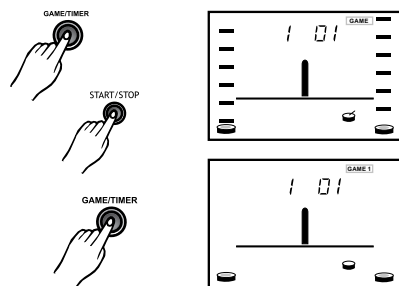

TEMPO/TAP

Press **[TEMPO]** to enter tempo mode, LCD temporarily display the tempo value with tempo icon for 3 seconds. Press **[+]** **[-]** to adjust the tempo value.

You are also allowed to set the metronome tempo by hitting the pad. Briefly hold down the **[TEMPO]** button for 3 seconds to enter tap mode. "TAP" icon flashes. Hit the pad 4 times to set the tempo, which value is determined by the interval of the last 2 hitting.

Note: in game mode, tap function is disenabled.

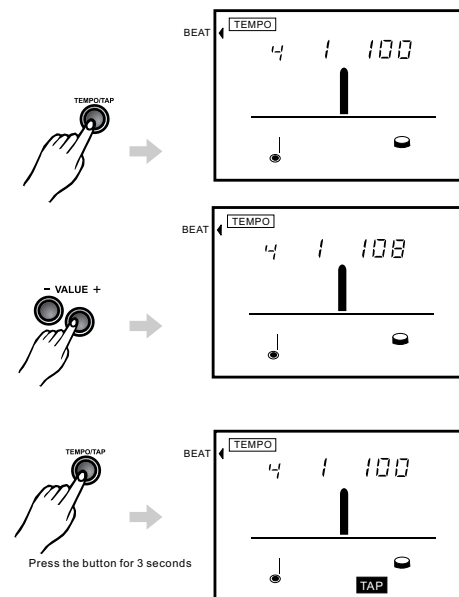

Record

Press **[RECORD]** button to enter record mode. "Record" indicator lightened on LCD. It will flash if the recorded data has been stored to the digital drum.

Start Recording

In record mode, press the **[RECORD]** button to start to record a new pattern.

The drum will now play the pattern (beat and rhythm) already set in metronome, and you can play according to this pattern.

If you'd like to mute the background pattern, set the volume of metronome to 0 before recording and only your own playing will sound during record mode.

Stop Recording

In recording process, press **[RECORD]** or **[START/STOP]** button to stop it.

Playback

In record mode, press the **[START/STOP]** button to playback the user pattern.

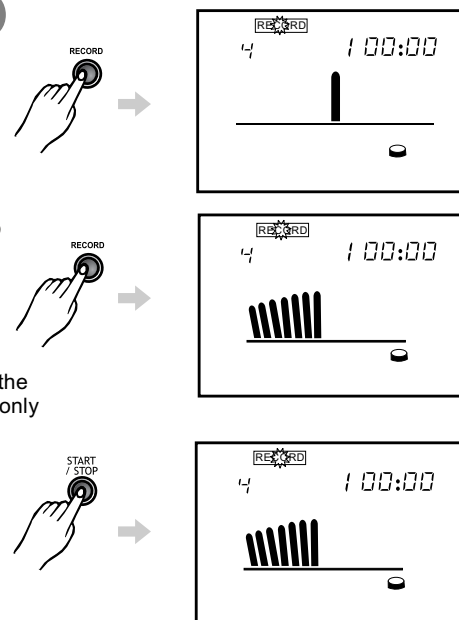

Parameter Save And Factory Set

Parameter Save

The digital drum can save the current setting, for example: beat/rhythm type, click/pad sound, tempo value, etc.

Factory Setting

Press both [+] and [-] buttons, then turn the power on, the digital drum will reset the factory setting.



Battery

When using the battery to supply power, LCD will display the battery level indicator. The battery level indicator  at the full position of the display when the battery power is sufficient, it means the system work in optimal status. The higher left of the display, the stronger the power in the battery.

The battery level indicator  at the lower right of the display when the battery power drops, it means the system work normally, be note that the insufficient battery power may cause operation unstable, such as the velocity checking.

The battery level indicator  is empty and begins to flash when the battery power is low, you are suggested to replace the battery.

Pad Sound List

No.	NAME	No.	NAME
	Snare (bank 10)	35	Standard tom3
01	Standard snare	36	Standard tom4
02	Standard snare rim	37	Standard tom5
03	Rock snare	38	Standard tom6
04	Rock snare rim	39	Electronic tom1
05	Room snare	40	Electronic tom2
06	Room snare rim	41	Electronic tom3
07	Jazz snare	42	Electronic tom4
08	Jazz snare rim	43	Electronic tom5
09	Funk snare	44	Electronic tom6
10	Funk snare rim		CRASH (bank 16)
11	Hiphop snare	45	Standard hihat cl
12	Hiphop snare rim	46	Standard hihat Ped
13	Electronic snare1	47	Standard hihat Op
14	Electronic snare2	48	Rock hihat Cl
15	Electronic snare3	49	Rock hihat Ped
16	Electronic snare4	50	Rock hihat Op
17	Electronic snare5	51	Standard hihat cl_op
18	Electronic snare6	52	Rock hihat cl_op
19	Electronic snare7	53	Jazz hihat cl_op
20	Electronic snare8	54	Standard Crash
21	Electronic snare9	55	Rock Crash
22	Electronic snare10	56	Standard Ride
	Kick (bank 12)	57	Rock Ride
23	Standard kick		METRØ (bank 8)
24	Rock kick	58	METRONOME-1
25	Room kick	59	METRONOME-2
26	Jazz kick	60	CLAVES-1
27	Funk kick	61	CLAVES-2
28	Hiphop kick	62	STICKS-1
29	Electronic snare1	63	STICKS-2
30	Electronic snare2	64	COWBELL-1
31	Electronic snare3	65	COWBELL-2
32	Electronic snare4		
	Tom (bank 14)		
33	Standard tom 1		
34	Standard tom 2		

Game Demo List

SONG LIST			
No.	name	beat	style
Easy			
1	Country_easy	4\4	Country
2	Country_hard	4\4	Country
3	6/8 Ballad_easy	6\8	Ballad
4	6/8 Ballad_hard	6\8	Ballad
5	8 beat ballad_easy	4\4	Ballad
6	8 beat ballad_hard	4\4	Ballad
7	Pop bossa_easy	4\4	Latin
8	Pop bossa_hard	4\4	Latin
9	Funk_1_easy	4\4	Funk
10	Funk_1_hard	4\4	Funk
11	8 beat pop_easy	4\4	Pop
12	8 beat pop_hard	4\4	Pop
13	Ballad_easy	4\4	Ballad
14	Ballad_hard	4\4	Ballad
15	Blues_1_easy	4\4	Blues
16	Blues_1_hard	4\4	Blues
17	Bossa_easy	4\4	Latin
18	Bossa_hard	4\4	Latin
19	Dance_1_easy	4\4	Dance
20	Dance_1_hard	4\4	Dance
Medium			
21	Big band_easy	4\4	Jazz
22	Big band_hard	4\4	Jazz
23	Dance_2_easy	4\4	Dance
24	Dance_2_hard	4\4	Dance
25	Funk_2_easy	4\4	Funk
26	Funk_2_hard	4\4	Funk
27	Funk_3_easy	4\4	Funk
28	Funk_3_hard	4\4	Funk
29	Fusion_easy	4\4	Fusion
30	Fusion_hard	4\4	Fusion

31	Jazz_1_easy	4\4	Jazz
32	Jazz_1_hard	4\4	Jazz
33	Jazz_2_easy	4\4	Jazz
34	Jazz_2_hard	4\4	Jazz
35	March_1_easy	4\4	March
36	March_1_hard	4\4	March
37	Reggae_easy	4\4	Reggae
38	Reggae_hard	4\4	Reggae
39	Latinjazz_easy	4\4	Rock
40	Latinjazz_hard	4\4	Rock
Hard			
41	March_2_easy	4\4	March
42	March_2_hard	4\4	March
43	Rock Shuffle_easy	4\4	Rock
44	Rock Shuffle_hard	4\4	Rock
45	Metal_easy	4\4	Rock
46	Metal_hard	4\4	Rock
47	Pop_easy	4\4	Pop
48	Pop_hard	4\4	Pop
49	R&B_easy	4\4	R B
50	R&B_hard	4\4	R B
51	Rock_1_easy	4\4	Rock
52	Rock_1_hard	4\4	Rock
53	Rock_2_easy	4\4	Rock
54	Rock_2_hard	4\4	Rock
55	Samba_easy	4\4	Latin
56	Samba_hard	4\4	Latin
57	Shuffle_easy	4\4	Fusion
58	Shuffle_hard	4\4	Fusion
59	Swing_easy	4\4	Jazz
60	Swing_hard	4\4	Jazz

