



Precision Roller Pinion System



Linear Rack and Pinion Systems



In accordance with Nexen's established policy of constant product improvement, the specifications contained in this manual are subject to change without notice. Technical data listed in this manual are based on the latest information available at the time of printing and are also subject to change without notice.

Technical Support: 800-843-7445
(651) 484-5900

www.nexengroup.com

	<p style="text-align: center;"> DANGER</p> <p>Read this manual carefully before installation and operation. Follow Nexen's instructions and integrate this unit into your system with care. This unit should be installed, operated and maintained by qualified personnel ONLY. Improper installation can damage your system, cause injury or death. Comply with all applicable codes.</p>	
---	---	---

This document is the original, non-translated, version.

Conformity Declaration: In accordance with Appendix II B of CE Machinery Directive (2006/42/EC):

A Declaration of Incorporation of Partly Completed Machinery evaluation for the applicable EU directives was carried out for this product in accordance with the Machinery Directive. The declaration of incorporation is set out in writing in a separate document and can be requested if required.

This machinery is incomplete and must not be put into service until the machinery into which it is to be incorporated has been declared in conformity with the applicable provisions of the Directive.

Nexen Group, Inc.
560 Oak Grove Parkway
Vadnais Heights, Minnesota 55127

ISO 9001 Certified

Table of Contents

General Safety Precautions	4
System Design Overview	5
General System Requirements	5
Rack Requirements	6
Pinion Requirements	6
General Design Guidelines	7
Installation	7
Rack Installation	8
Adding Additional Racks	8
GEN A Alignment Tool Provisions	9
Roller Pinion Installation	11
Shaft Mounted Pinion Installation	11
Flange Mount Pinion Installation (ISO 9409)	12
Applying Preload	14
System Alignment Verification	15
RPS System Operation	16
Disengaging the Roller Pinion	16
Lubrication	17
Warranty	18

GENERAL SAFETY PRECAUTIONS

	! WARNING
	Use appropriate guarding for rotating components. Failure to guard could result in serious bodily injury.







	! DANGER
	This product has moving parts that can crush or cut appendages. Provide adequate spacing or guarding from any operating product.

	! WARNING
	Failure to properly support the load before disengaging the RPS system could cause serious harm to operators or equipment.

	! WARNING
	Ensure proper guarding of the product is used. Nexen recommends the machine builder design guarding in compliance with OSHA 29 CFR 1910 "Occupational Safety and Health Hazards".

	! CAUTION
	Use lifting aids and proper lifting techniques when installing, removing, or placing this product in service.

	! CAUTION
	Watch for sharp features when interacting with this product. The parts have complex shapes and machined edges.

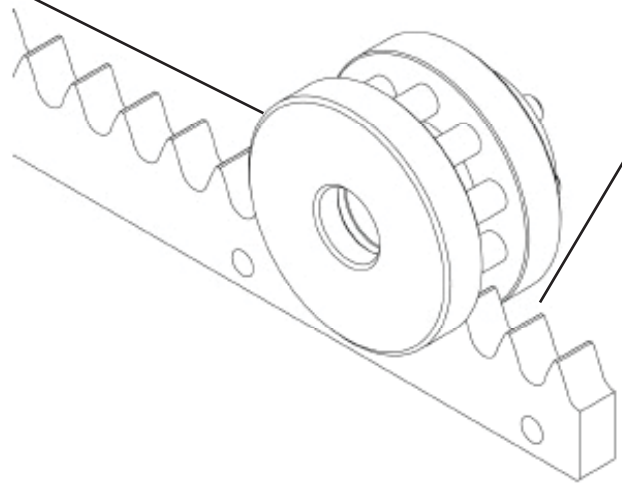
<table border="1" style="width: 100%;"> <tr> <td rowspan="2"></td> <td style="background-color: #f4a460;">! WARNING</td> </tr> <tr> <td>Use appropriate guarding for rotating components. Failure to guard could result in serious bodily injury.</td> </tr> </table>		! WARNING	Use appropriate guarding for rotating components. Failure to guard could result in serious bodily injury.	<table border="1" style="width: 100%;"> <tr> <td rowspan="2"></td> <td style="background-color: #ff0000;">! DANGER</td> </tr> <tr> <td>This product has moving parts that can crush or cut appendages. Provide adequate spacing or guarding from any operating product.</td> </tr> </table>		! DANGER	This product has moving parts that can crush or cut appendages. Provide adequate spacing or guarding from any operating product.
		! WARNING					
	Use appropriate guarding for rotating components. Failure to guard could result in serious bodily injury.						
	! DANGER						
	This product has moving parts that can crush or cut appendages. Provide adequate spacing or guarding from any operating product.						
							

SYSTEM DESIGN OVERVIEW

The machine design guidelines, installation procedures, specifications, and tolerances, listed in this document are designed to obtain Nexen's published RPS performance ratings with reasonable effort. In some cases some of these requirements can be deviated from with a reduction in the RPS system performance. Contact Nexen to determine if the desired deviation is possible and its effect on system performance.

GENERAL SYSTEM REQUIREMENTS

- Unlike traditional rack and pinion drives, the RPS system has zero mechanical clearance and requires a system preload for proper operation. This preload must remain relatively consistent over the entire run to obtain optimal system performance and life. To achieve this it is crucial that the guiding system be as parallel as possible to the RPS system and not converge or diverge at any point. If the system converges, the pinion preload will become excessive and increase noise, reduce pinion roller bearing life, and potentially bind the system. If the system diverges, pinion preload will be lost causing backlash, a loss of positional accuracy, increase in noise, and reduction in system life. The main consideration is that the guiding system and the RPS system are rising or falling at the same place in the run so the pinion preload remains within specifications. The best way to minimize the variance between the guiding system and the Roller Pinion system is to machine their mounting locations in a single machining operation. See Figures 1 and 2 for more details.
- Make sure that the machine bed and guiding system are rigid enough to prevent deflection that will affect RPS system preload and pinion alignment.
- The rack and guiding system installation parallelism tolerances shown in Figure 2 are greater than the system preload. The RPS system has been designed to provide its rated performance under these conditions.
- The bottom of the rack and one side must be supported by a step in the machine bed at least half the rack thickness. The rack should not be supported only by fasteners or pins. See Figure 3 for specifications.
- Over long distances a single piece machine bed will become impractical requiring a segmented bed. When installing the guiding system and the RPS rack, their joints should not be located near the machine bed joints but span them as much as possible.
- The RPS system generates a separation force between the pinion and rack. Make sure this is accounted for when selecting the guiding system or evaluating reducer or motor overhung load ratings. See product data for maximum pressure angle specifications.
- The RPS system requires a mechanism to achieve proper system preload. It is recommended that the pinion be moved into the rack not vice versa. The recommended method is to mount the servo drive system on a sliding bracket that has an adjustment to push it into and pull it away from the rack. Another possible preloading method utilizes a bracket with eccentric mounting slot pattern. Nexen offers a preloading mechanism that is easy to integrate into your application as shown in Figure 18. Spring loaded preloading mechanisms shall not be used since the spring force required to counteract the separation forces are much higher than the allowed preloading force and would cause a reduction in pinion needle bearing life and increase system noise. See Figure 3 for more details.
- Under most circumstances, the RPS system requires periodic lubrication. In special cases, Premium and Endurance Grade RPS can be operated lubrication free if the maximum speed does not exceed 0.5 m/s [1.64 ft/s]. Typically this will involve dirty environments where contaminants will be attracted/stick to the lubricant on the rack creating mechanical interference or an abrasive paste that can accelerate wear. Other applications where no rack lubrication may be beneficial include food processing, clean rooms, coating, and others where low particle emissions are desirable. If the RPS system is operated lubrication free there may be some reduction in life which could vary depending on the application. Do not run the RPS system lubrication free unless there is a strong reason to do so. The Standard and Universal Grades of RPS shall not be run lubrication free under any circumstances. Consult Nexen for more information regarding alternative lubrication options or lubrication-free applications.
- Do not use the RPS system in environments with temperatures outside of a -5 - 40° C (23 - 104° F) range, or with wide temperature variations since thermal expansion can effect the preload and meshing of the system. If you have an application with any of these characteristics consult Nexen.

- RPS systems are surface treated with various products depending on the model. All standard pinion product offerings include uncoated, bearing grade steel rollers. Pinion roller corrosion will lead to pinion needle bearing damage and then system failure. Always protect the pinion from adverse conditions. As the surface treatments vary depending on RPS model, review surface treatment specifications carefully to determine whether the RPS system is suitable for your application based on your familiarity with the corrosion resistant surface treatment or through testing. Nexen makes no claims for RPS corrosion resistance in any application.
- Nexen can provide additional tapped, untapped or countersunk holes in the side or bottom of the rack or cut the rack to a specific length for an additional charge.

RACK REQUIREMENTS

- **CAUTION** Handle the rack with care; it is a high precision product. Do not drop it, allow anything to fall on it, or place it on non-flat surfaces that could effect rack straightness. Doing so may negatively effect RPS system performance.
- Five sides of the RPS rack are reference surfaces. The side displaying the part number, or ends that have been cut (not factory full or half sections) are non-reference surfaces. The side displaying the part number should not be mounted against the machine bed and cut rack ends must be at the end of the run.
- Secure the rack using all of the available mounting holes to a precision step in the machine bed. Refer to Table 2 for proper fastener tightening torque. This will ensure the highest degree of rack stability.
- Install the RPS system at the temperature at which it will be used to minimize thermal expansion or contraction effecting the positional accuracy of the RPS system.
- The RPS rack is hardened on the tooth faces only.
- If joining multiple rack segments a special alignment tool is required and is available from Nexen. The alignment tool ensures proper pinion meshing and system accuracy when the pinion crosses rack joints. When the adjacent racks are properly positioned, there will be a 0.1 - 0.2 mm gap between their ends. See Figures 4 and 8 for details.
- Avoid mounting the rack teeth up since debris could collect on the rack and interfere with the meshing of the RPS system. If the teeth must be mounted up, shield the RPS system from debris or install an air knife just ahead of the pinion.

PINION REQUIREMENTS

- Verify shaft runout and diameter tolerances meet Nexen specifications before mounting the pinion. See Figure 11.
- For shaft mounted pinions the shaft length must meet the minimum shaft insertion requirements for proper support and torque transmission. See the pinion dimensional drawings in the RPS Application and Selection Guide for minimum shaft insertion values.
- If using a flange mount pinion verify the dimensions and tolerances of the gearhead flange meet the specifications of the ISO 9409 standard.
- Mount the pinion as close to a support bearing as possible to minimize shaft deflection.
- The pinion roller bearings are sealed, however it is still recommended that the pinion be shielded from liquids, dust, and debris.
- Multiple pinions may be used on a single axis to drive a common load. When sizing the RPS system, it is important to carefully evaluate the loading that is to be seen by each pinion. Perfect load sharing between multiple pinions driving a common load is difficult to achieve in practice and therefore additional service factors are typically recommended. Contact Nexen for more information on sizing the RPS system under these conditions.
- The RPS system can be operated such that the pinion remains stationary while the rack moves. In this scenario, a supporting structure and guiding system is still required for the rack such that the pinion preload and alignment remains within specifications.

GENERAL DESIGN GUIDELINES

In order to minimize backlash, obtain the highest positional accuracy, and minimize wear on the rack, the RPS system must be installed on a rigid, straight, flat mounting surface with the tolerances shown in Figure 2.

The following requirements must be met to ensure proper RPS operation:

- Mount a linear guide rail on a surface parallel to the RPS rack mounting surface with the same flatness as the rack mounting surface as shown in Figure 2.
- The pinion shaft must be parallel (0.03 mm [0.001 in]) to the rack mounting surface opposite the rack teeth and the angle between the pinion shaft and the face of the rack must be $90^\circ \pm 0.1^\circ$ maximum as shown in Figure 1).

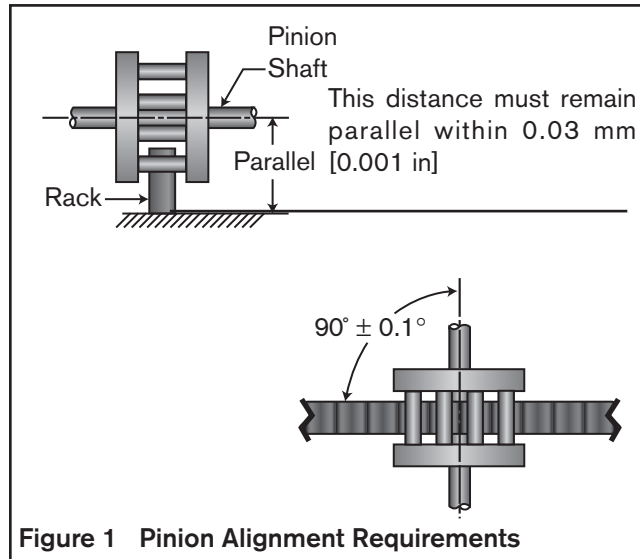

Figure 1 Pinion Alignment Requirements

- The pinion shaft must be supported adequately to ensure full contact of the pinion rollers along the face of rack teeth.

INSTALLATION

The mounting surface for both the rack and the guiding system must be parallel within the specifications shown in Figure 2. This parallelism requirement is best achieved by machining the mounting locations for both the guiding system and rack in the same machining operation. (Refer to PROPER SYSTEM ALIGNMENT and Figures 1 and 2 for Possible Mounting Configurations.)

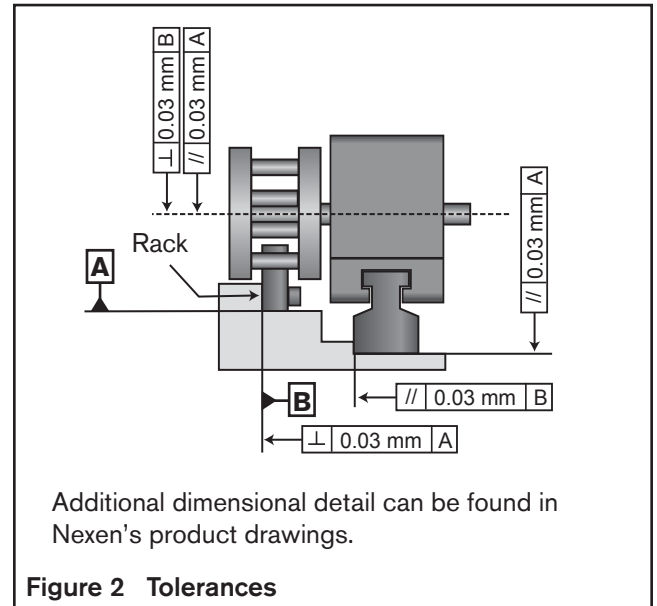

Figure 2 Tolerances

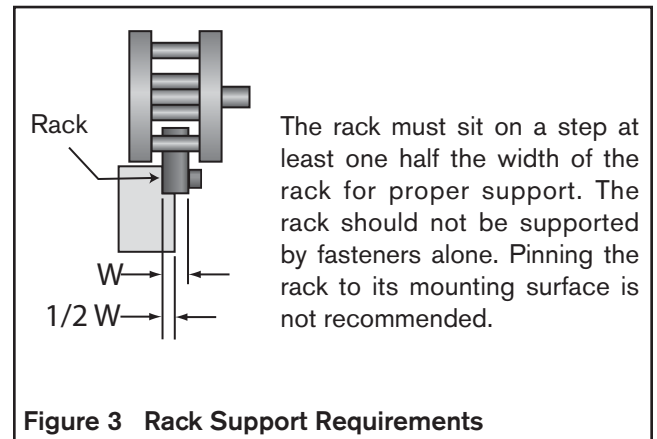

Figure 3 Rack Support Requirements

Systems may be mounted at any angle as long as the rack, guiding system and mounting surface remain parallel with the shaft at a 90° angle from the rack.

Nexen recommends orienting the rack teeth downward or to the side so it minimizes the possibility of debris collecting on the teeth and causing meshing interference. The rack has 5 reference surfaces and includes all sides except the side with the product number. The non-reference face with the product number should not be placed against the machine bed surfaces. Any rack ends that have been cut must be located at the end of the run; the pinion must not cross cut rack ends.

RACK INSTALLATION

1. Ensure that the mounting surface and rack are completely clean, free of burrs, or anything that could interfere with full contact with the mounting surfaces.
2. With the guiding system in place mount a dial indicator on the carriage and measure the perpendicularity and parallelism variance on the two rack mounting surfaces by moving the carriage down the run and monitoring the dial indicator readings. Verify they meet or exceed specifications of ± 0.03 mm [± 0.001 in.] as shown in Figure 4. If variance is not within specifications, verify guiding system installation and correct if possible. Mark the location of the high point in the mounting surface the rack bottom sits on.

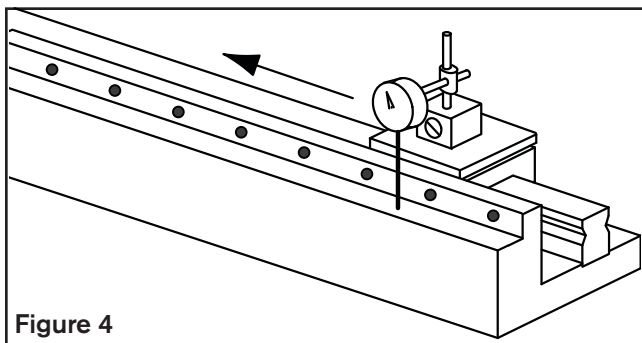

Figure 4

3. Start rack installation at the high point in the mounting surface the rack bottom sits on. This may not be at the end of the run.

Additional sections of rack will be shimmed as required throughout the rest of the run to bring the rack tooth peak variance into specifications relative to the first rack section.

4. Apply a serviceable thread locking compound to the customer supplied mounting bolts, lightly secure the first rack length to the mounting surface and clamp it in place while protecting the rack teeth by distributing the clamp load over several teeth. Make sure the clamps are close to each bolt as they are tightened to ensure full rack to mounting surface contact. See Figure 5. Socket head cap screws are recommended for maximum pinion shoulder clearance. Make sure the side of the rack with the part number on it is not against the mounting surface and any cut rack ends are at the end of the run.
5. Tighten the mounting bolts on the first rack alternately and incrementally 10%, 50%, then fully torque, working from the center of the rack towards the ends. Refer to Table 2 for recommended tightening torques.

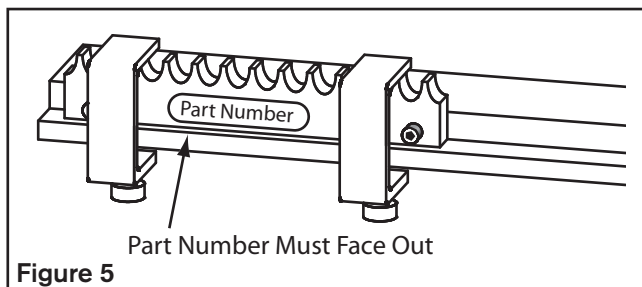

Figure 5

6. Once the rack mounting bolts are fully torqued, verify tooth peak variance is less than ± 0.03 mm [± 0.001 in.] by placing a dial indicator on the movable carriage with the indicator tip on the tooth peaks. Measure the tooth peak variance at points throughout the rack section as shown in Figure 6.

If the tooth peak variance is out of specifications and the mounting surface was in specifications dismount the rack and inspect for dirt, burrs, or anything that would prevent proper rack to mounting surface seating.

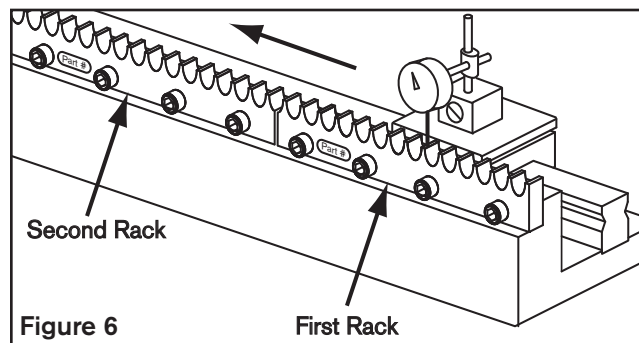

Figure 6

If the mounting surface is out of recommended specifications then shimming between the rack bottom and the mounting surface will be required. Locate the high point within the rack section and shim all other points to meet it.

When shimming, it is recommended to support the rack as much as possible, not just short pieces near mounting bolts.

Adding Additional Racks

NOTE: Alignment Tools for each RPS size are required and available for purchase from Nexen. This tool is required for proper installation of multiple rack segment runs.

7. Butt the second rack segment against the first fully secured rack on the mounting surface and lightly secure it with fasteners with serviceable thread locking compound applied so it is in full contact with the mounting surface but still moveable within the rack mounting hole tolerances.
8. Mount the Alignment Tool between the two racks utilizing the adjacent tooth roots of each rack while being careful not to damage the rack or alignment tool as shown in Figures 7 and 8. The GEN B alignment tool has a different appearance but functions the same and has no bolt down provisions. It is hand pressed into place to set the rack spacing as described on the next page.

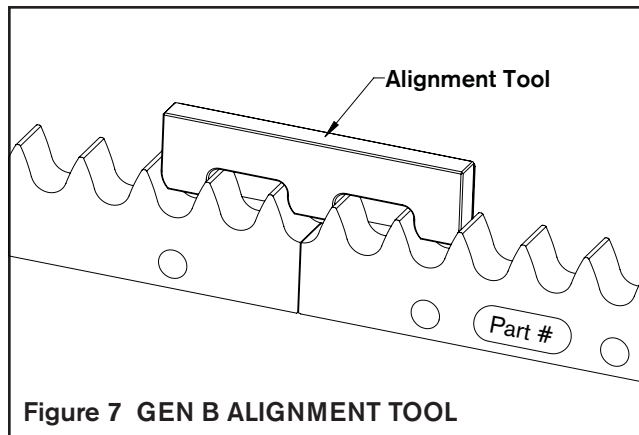

Figure 7 GEN B ALIGNMENT TOOL

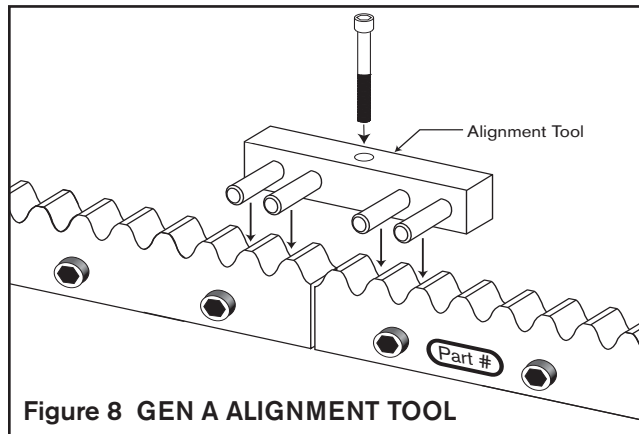

Figure 8 GEN A ALIGNMENT TOOL

The bolt can either pass through the alignment tool from the top and thread into the machine bed or pass through the machine bed and thread into the alignment tool. See Table 1 for bolt sizes depending on method chosen.

If fastening the alignment tool in place is not possible or in the case of GEN B, it can also be clamped in place by placing a small piece of flat stock across the two alignment tool pins on each rack end and clamping them down by some other provision.

If fastening or clamping is not possible or in the case of GEN B, the alignment tool can be manually seated across the rack joint while pressing it forcefully into the rack. When the adjoining rack section is properly spaced, the alignment tool will feel solidly seated when

alternately pushing down on opposite ends of the tool. If not using the bolt down method, skip to Step 12.

9. Fasten the Alignment Tool to the mounting surface using customer supplied fasteners while making sure the face of the alignment tool is fully seated against the rack face and tighten to the initial torque value in Table 1.
10. Tighten the second rack's bolts to 10% of the torque values in Table 2.
11. Torque the alignment tool to the final torque specified in Table 1.
12. Torque the second rack to 50% of the torque listed in Table 2 working from the middle of the rack to the ends. Then repeat with 100% torque, as specified in Table 2.
13. Carefully remove the alignment tool, while avoiding any damage to the rack or alignment tool.
14. Starting on the first rack perform the tooth peak variance check and extend it to the second rack as covered in step 6. If the tooth peak variance on the second rack is out of specifications shim it to match the first rack. Always reference the runout of additional rack sections against the first rack installed at the high point in the run as shown in Figure 9.
15. Repeat Steps 7 through 14 for any additional rack sections.

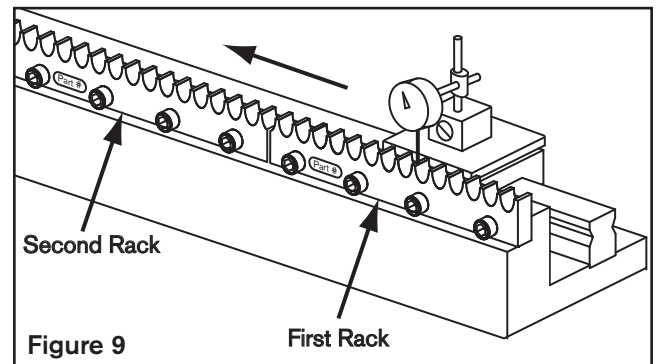

Figure 9

GEN A ALIGNMENT TOOL PROVISIONS

When joining multiple sections of rack it is recommended that the provisions shown in Figure 10 be used whenever possible.

In some applications this may not be practical. In these cases the GEN A alignment tool can be clamped in place by placing the alignment tool in position across the rack joint and laying a flat steel bar across the pins and clamping against the steel bar.

If clamping is not possible or in the case of GEN B, the alignment tool can be manually seated across the rack joint while pressing the pins forcefully into the rack teeth. When the adjoining rack section is properly spaced, no movement should be felt when alternately pushing down on opposite ends of the alignment tool.

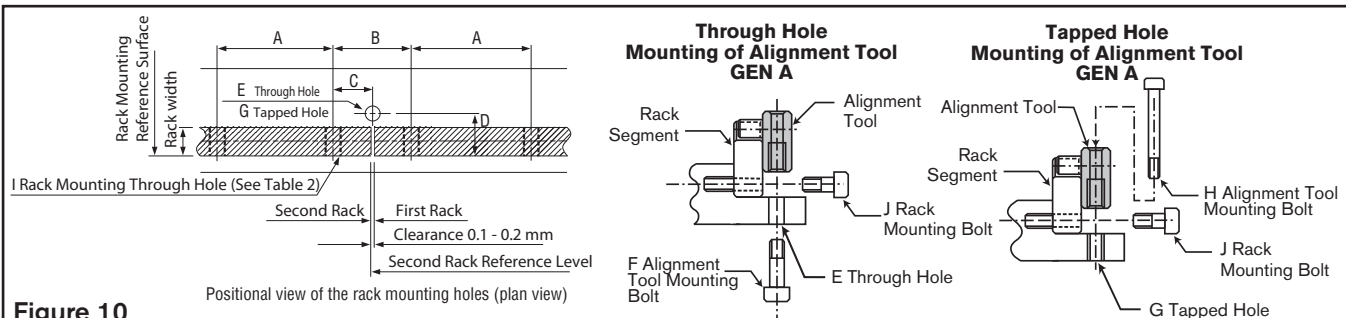

Figure 10

The dimensions below are nominal in mm and applicable only to standard catalog offerings. Refer to Nexen product drawings and CAD files for your product numbers for precise dimensions. Special and cut sections of rack may not conform to these dimensions. The RPS 10 & 12 alignment tools do not bolt down so no data is listed for them below.

RPS Size	A	B	C	D	Through Hole Mounting		Tapped Hole Mounting		I	J
					E	F	G & H	H		
16	96	32	16	19.5	9	M8 x 1.25	M6 x 1.00	M6-50	7	M6
20	100	100	50	25.5	11	M10 x 1.50	M8 x 1.25	M6-60	9	M8
25	100	100	50	30.5	14	M12 x 1.75	M10 x 1.50	M10-75	11	M10
32	96	32	16	36.5	14	M12 x 1.75	M10 x 1.50	M10-95	14	M12
40	120	160	80	43.5	14	M12 x 1.75	M10 x 1.50	M10-95	18	M16
4014	80	120	60	54.0	14	M12 x 1.75	M10 x 1.50	M10-95	18	M16
50	62.50	62.50	31.25	54.0	14	M12 x 1.75	M10 x 1.50	M10-95	18	M16

Dimensions apply to standard length rack sections. Cut lengths and customs could vary. Refer to drawings for your specific product numbers. * Bolt length will vary based on machine design.

Table 1

Alignment Tool Mounting Bolt Specifications					
RPS Size	Through Hole		Tapped Hole		
	Bolt Size	Tightening Torque Initial/Final Nm [in-lb]	Thread	Depth mm [in]	Tightening Torque Initial/Final Nm [in-lb]
16	M6	1/5 [9/44]	M8	16 [0.63]	1/8 [7/71]
20	M8	1/8 [7/71]	M10	20 [0.79]	1/12 [9/106]
25 & 32	M10	2/28 [18/248]	M12	24 [0.94]	2/30 [18/266]
40 & 4014	M10	3/32 [27/283]	M12	24 [0.94]	3/35 [27/310]
50	M10	3/32 [27/283]	M12	24 [0.94]	3/35 [27/310]

Table 2

Bolt Type	Mounting Material		
	Steel	Cast Iron	Aluminum
Rack Mounting Tightening Torque for Socket Head Cap Screws (Class 10.9 or better)			
M5	8.2 Nm [73 in-lb]	5.4 Nm [48 in-lb]	4.0 Nm [35 in-lb]
M6	16 Nm [140 in-lb]	10 Nm [89 in-lb]	8 Nm [71 in-lb]
M8	31 Nm [275 in-lb]	20 Nm [177 in-lb]	15 Nm [128 in-lb]
M10	68 Nm [602 in-lb] 45 Nm [398 in-lb] (Versa Rack Only)	45 Nm [398 in-lb]	33 Nm [292 in-lb]
M12	120 Nm [1062 in-lb]	78 Nm [690 in-lb]	58 Nm [513 in-lb]
M16	196 Nm [1735 in-lb]	131 Nm [1160 in-lb]	98 Nm [867 in-lb]
Rack Mounting Tightening Torque for Stainless Steel Screws (Class 8.8 or better)			
M5	5 Nm [44 in-lb]	5 Nm [44 in-lb]	4.0 Nm [35 in-lb]
M6	10 Nm [89 in-lb]	10 Nm [89 in-lb]	8 Nm [71 in-lb]
M8	19 Nm [168 in-lb]	19 Nm [168 in-lb]	15 Nm [128 in-lb]
M10	41 Nm [363 in-lb]	41 Nm [363 in-lb]	33 Nm [292 in-lb]
M12	70 Nm [620 in-lb]	70 Nm [620 in-lb]	58 Nm [513 in-lb]
M16	137 Nm [1213 in-lb]	131 Nm [1160 in-lb]	98 Nm [867 in-lb]

ROLLER PINION INSTALLATION

Note: There are two pinion mounting styles, shaft or flange mount. Refer to the following section that applies to your situation. In either case it is critical to minimize radial variance. It will effect pinion preload and positional accuracy throughout the run.

Shaft Mounted Pinion Installation

NOTES:

- Refer to product drawings for shaft details.
- Refer to **GENERAL DESIGN GUIDELINES** and **Figures 1 and 2** for Roller Pinion mounting requirements.
- The pinion should be mounted as close to a shaft supporting bearing as possible to minimize shaft deflection and obtain optimal performance.
- The shaft the pinion is mounted on must meet minimum shaft insertion requirements as shown in the RPS Selection Guide drawings for proper pinion support and maximum torque transmission.

1. Clean the shaft the pinion will be mounted on and verify that variance is less than ± 0.013 mm [± 0.0005 in] as shown in Figure 11.
2. Inspect the shaft, pinion bore and the inner and outer coupling halves to ensure they are clean and have no defects.
3. Put oil that does not contain any pressure additives on the shaft, the tapered part of the coupling and bolts as shown in Figure 11. Do not lubricate the bore of the pinion coupling or shaft where the coupling contacts it or the torque transmission capacity of the coupling will be reduced.

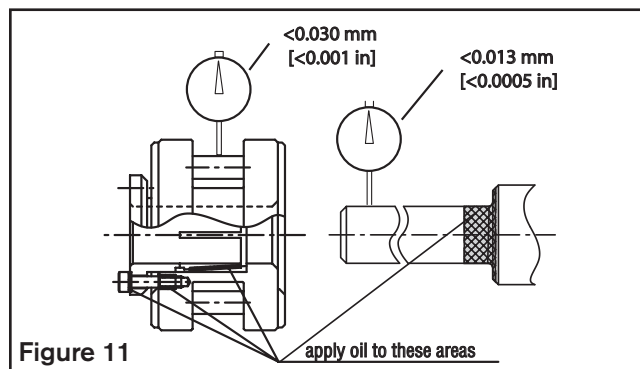

4. Insert the outer coupling half into the roller pinion bore until it bottoms in the roller pinion.
5. Insert the inner coupling half into the outer coupling half (previously inserted into the pinion) while ensuring that the inner and outer coupling half slots are not

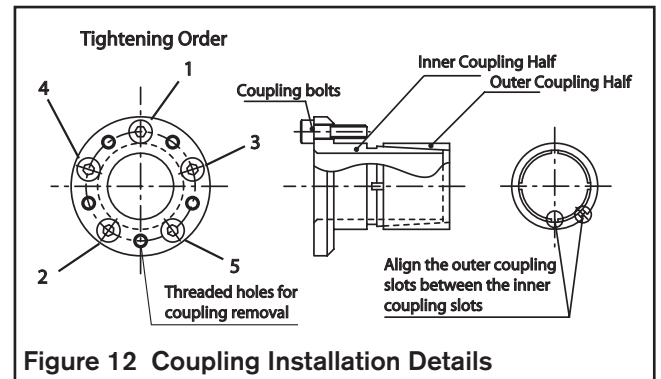

Figure 12 Coupling Installation Details

aligned as shown in Figure 12. For RPS32 and below you will also have to simultaneously ensure the coupling bolt through holes align with the pinion bolt holes. On RPS40 and larger the coupling bolts thread into the other half of the coupling, not the pinion body so misalignment is not possible. The threaded holes in the outer coupling end are for coupling removal.

NOTE: Ensure that the slots in the two components that make up the coupling are not aligned as shown in Figure 12.

6. Insert the shaft into the pinion and coupling bore.
7. Insert the coupling fasteners into the through holes. Only use the provided coupling fasteners.
8. Locate the pinion on the shaft and lightly tighten the fasteners to take clearance out of all the coupling parts but still allow the pinion to be moved axially on the shaft. Position the pinion and coupling assembly on the shaft so that the gap between rack face and pinion roller bearing shoulders is even on both sides. As the coupling fasteners are tightened the pinion will be drawn slightly in the coupling direction so it is recommended that the pinion and coupling assembly be offset axially away from the coupling side 3 - 5 mm [0.1 - 0.2 in] initially so when the coupling fasteners are fully torqued the pinion ends up centered on the rack.
9. Equally tighten the coupling fasteners with 25% of the recommended tightening torque listed in Table 3. Start tightening at the top fastener and alternate back and forth across the face in a star pattern as shown in Figure 12. (The number of bolts will vary with RPS size.) Repeat this procedure with 50% and then full torque. An additional 1 or 2 repetitions at full torque are recommended to ensure all fasteners have reached their target torque values. Progressive tightening of non-adjacent coupling fasteners is important to prevent any misalignment of components while installing the coupling.

10. Once the fasteners are fully torqued verify the pinion is centered on the rack. If not, measure the positional error and then remove the pinion as described in the **DISENGAGING THE ROLLER PINION** section. Repeat the pinion installation procedure and offset the pinion by the recorded error plus the previous off set value. When the pinion is fully torqued and properly centered on the rack then verify pinion concentricity at the center of the pinion rollers as shown in Figure 11. Indicated concentric runout on this surface must be less than ± 0.030 mm [± 0.0010 in].

Table 3 Pinion Coupling Bolt Information

Model	Bolt Size	Tightening Torque
RPS10	M3 (4X)	1.9 Nm [16.8 in-lb]
RPS12	M4 (4X)	4.1 Nm [36.3 in-lb]
RPS16	M4 (5X)	3.5 Nm [31.0 in-lb]
RPS20	M5 (5X)	7.0 Nm [62.0 in-lb]
RPS 25 & 32	M6 (5X)	12.0 Nm [106.2 in-lb]
RPS40	M6 (8X)	12.0 Nm [106.2 in-lb]
	M8 (10X)	24.4 Nm [216.0 in-lb]
RPS4014	M8 (8X)	38.0 Nm [336.3 in-lb]
	M8 (10X)	32.6 Nm [288.5 in-lb]

	CAUTION
	Preload must be applied before putting your system into operation. Refer to APPLYING PRELOAD to properly set preload for your RPS system.

Flange Mount Pinion Installation (ISO 9409)

1. Clean the gearhead mounting face and pilot bore inspecting for contaminates, burs, or surface defects that would interfere with full contact between the pinion and flange or cause runout.
2. Using a dial indicator, check the rotational flatness of the face as shown in Figure 13. Position the contact point of the indicator where the pinion will contact it. Rotate slowly for a minimum of one complete revolution and note the total amount of runout.

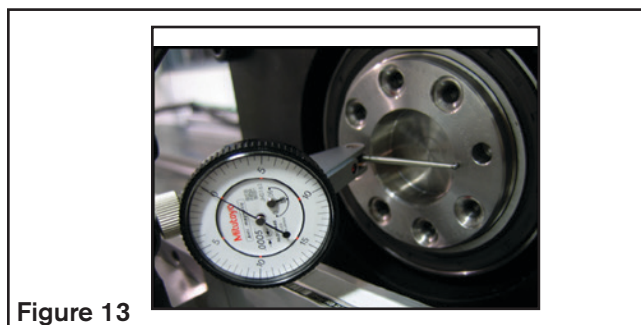

Figure 13

3. Position the contact point of the dial indicator at bottom dead center of the pilot bore as shown in Figure 14. Rotate slowly for a minimum of one complete turn and note the amount of total runout in one rotation.

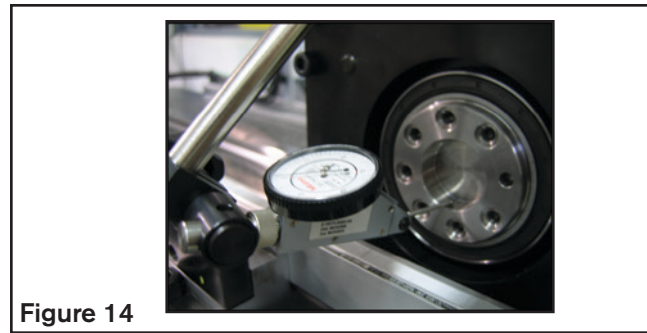

Figure 14

4. If either of the following conditions are true, the gearhead itself may contribute to excessive pinion preload variation, a reduction in pinion life and/or accuracy. The user should consider having the gearhead re-worked or replaced.
 - a. The measured total variance of the mounting face is greater than 0.013 mm [0.0005 in].
 - b. The measured total variance of the pilot bore wall is greater than 0.005 mm [0.0002 in].

Note: In some cases an adapter will be required to mount the pinion on the reducer. If so proceed with Step 5, if not skip to Step 13.

5. Clean the adapter flange and pilot where it will contact the gearhead flange inspecting for contaminates, burs, or surface defects that would interfere with full contact between the adapter and gearhead flange. See Figure 15.

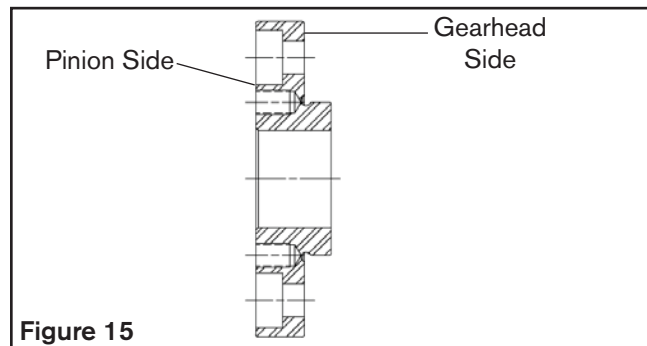

Figure 15

6. Apply a serviceable thread locking compound to the adapter mounting screws then assemble the adapter to the gearhead, leaving the mounting screws snug but do not tighten at this time as shown in Figure 16.
7. Position a dial indicator at bottom dead center of the pilot bore wall as shown in Figure 16 and zero the indicator. Rotate the assembly slowly by using the gearhead input shaft a minimum of one complete revolution while noting the dial indicator runout and mark the angular location in which the lowest reading occurs throughout the rotation.



Figure 16

8. If the measured total dial indicator runout of the adapter pilot bore is greater than 0.008 mm [0.0003 in], tap gently on the O.D. of the adapter using a soft hammer at the angular location in which the lowest reading occurred. Doing this will shift the center of the adapter closer to the center of rotation.
9. Repeat steps 7 and 8 until the total dial indicator runout is 0.008 mm [0.0003 in] or less.
10. Tighten the mounting screws to 50% of the specified torque specified in Table 4 in a star pattern that allows for an even distribution of axial clamping force. Then repeat the tightening pattern with 100% of the recommended torque.

Table 4

Adapter Fasteners	Tightening Torque Nm [in-lb]
ISO 16/20 (M5x0.8)	6.5 [58]
ISO 16/25 (M6x1.0)	11.5 [78]
ISO 20/25 (M6x1.0)	11.5 [78]
ISO 20/32 (M6x1.0)	11.5 [78]
ISO 32/40 (M8x1.25)	26 [156]
ISO 40/4014 (M10x1.5)	46 [273]

11. Re-torque the mounting screws once more to the full-specified torque value in Table 4 to ensure full torque has been reached on all fasteners. Tighten in the same order as above.
12. Repeat inspection Step 7 and verify the total dial indicator runout listed in Step 8 is achieved after fully torquing the adapter. If runout is out of specifications the adapter should be removed inspecting for contaminants, burs, or surface defects that would interfere with full contact between the adapter and gearhead flange. In some cases indexing the adapter relative to the gearhead flange can be helpful. Then repeat the adapter installation procedure starting with Step 6.

13. Clean the pinion flange and pilot where it will contact the adapter (if used) or gearhead flange inspecting for contaminants, burs, or surface defects that would interfere with full contact between the pinion and adapter (if used) or gearhead flange.

14. Apply a serviceable thread locking compound to the pinion mounting screws and assemble the pinion to the adapter (if used) or gearhead, leaving the mounting screws snug but do not tighten at this time.

15. Position a dial indicator on the center of the pinion rollers as shown in Figure 17 and zero it. Rotate pinion a minimum of one complete revolution by turning the gearhead input shaft while noting the amount of total dial indicator runout and mark the angular location on the pinion shoulder in which the highest reading occurs throughout the rotation. When the pinion is properly centered the concentric runout at the center of the pinion rollers must be less than ± 0.030 mm [± 0.0010 in].



Figure 17

If the measured total indicator variance of the pinion rollers is greater than ± 0.030 mm [± 0.0010 in], tap gently on the O.D. of the pinion using a soft hammer at the angular location in which the highest reading occurred. Doing this will shift the pinion center closer to the center of rotation.

16. Tighten the mounting screws to 50% of the specified torque specified in Table 5 below in a star pattern that allows for an even distribution of axial clamping force. Then repeat the tightening pattern with 100% of the recommended torque in Table 5.

Table 5

Pinion Fasteners	Tightening Torque Nm [in-lb]
RPS 16 (M3 x 0.5-APEX)	1.5 [13]
RPS 16 (M4 x 0.7)	5.3 [47]
RPS 20 (M5 x 0.8)	10 [88]
RPS 25 (M6 x 1.0)	17.5 [155]
RPS 32 (M6 x 1.0)	17.5 [155]
RPS 40 (M8 x 1.25)	40 [354]
RPS 4014 (M10 x 1.5)	70 [620]

17. Re-torque the mounting screws once more to the full-specified torque value in Table 4 to ensure full torque has been reached on all fasteners. Tighten in the same order as in Step 16.

18. Repeat concentric runout inspection Step 15 and verify concentric runout remains within specifications after fully torquing the pinion. If the runout is out of specifications the pinion should be removed inspecting for contaminants, burs, or surface defects that would interfere with full contact between the pinion and adapter (if used) or gearhead flange. Indexing the pinion relative to the adapter (if used) or gearhead may help in some cases. Repeat the pinion installation procedure starting with Step 13.

APPLYING PRELOAD

If you would prefer to not design your own pinion preloading mechanism, Nexen offers a high precision push bolt preloading system that bolts between the machine frame and servo reducer to simplify machine design and achieve optimal results. See figure 18.

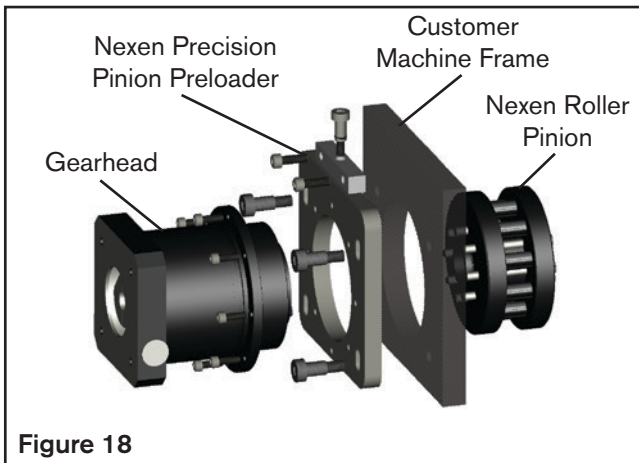

Nexen Precision Pinion Preloader product numbers and more information can be found at www.nexengroup.com on any of the RPS pinion pages under accessories in the left hand column.

To ensure optimal meshing of the roller pins with the rack teeth, the shaft must be preloaded to 0.010 - 0.015 mm [0.0004 - 0.0006 in] beyond full roller/tooth root engagement.

NOTE: Do not apply excessive preload. Preloading beyond 0.015 mm [0.0006 in] will decrease product life, increase noise, and cause vibration. When the RPS system is properly preloaded, there will be no tangential play between the rack and the pinion if the pinion is not allowed to turn and the carriage assembly forced back and forth in the direction of travel.

Refer to Figure 19 for suggested preload methods.

Preloading Procedure

Note: Be careful engaging the pinion and servo assembly to the rack to avoid damaging the rack teeth or pinion rollers.

1. With a dial indicator mounted on the movable carriage, measure off the tooth peaks. Move the carriage down the run taking frequent measurements to locate the high spot in the run. This is where the pinion preloading should be done to prevent excessive preload from occurring elsewhere in the run.

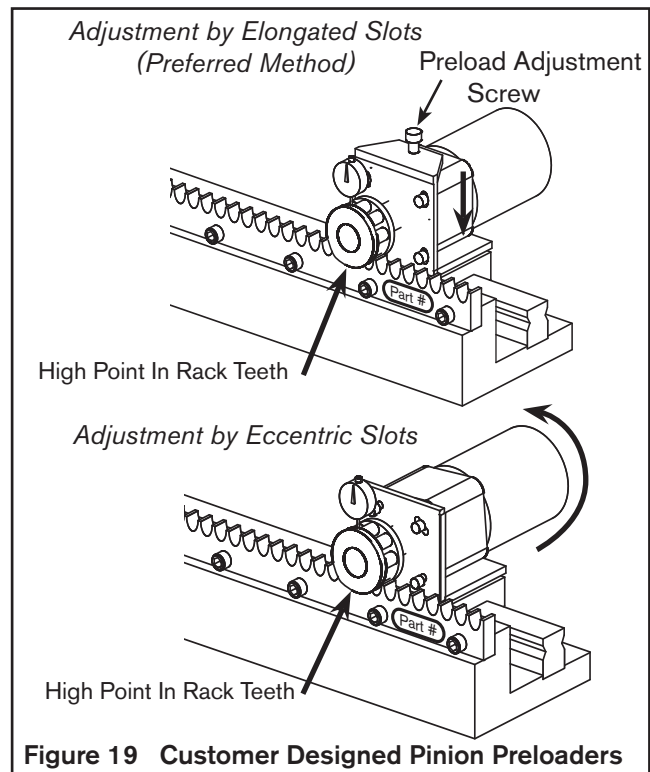

Figure 19 Customer Designed Pinion Preloaders

2. Apply serviceable thread locking compound to the pinion preloader slider bolts and install the servo and preload mechanism. Ensure the preload related bolts are just loose enough to allow the pinion to be pulled away from the rack teeth. For the Nexen Preloader System, this is approximately 0.2 - 0.3 Nm [2 - 3 in-lbs].

3. Verify pinion rotational axis is as close to 90° from the rack run axis, the pinion rotational axis is also parallel with the tooth tops or rack mounting surface, and the rack is centered between the pinion bearing flanges as shown in Figure 1.
4. Rotate the preload adjustment screw clockwise to separate the pinion from the rack. This will ensure that clearance is initially present. Then seat the pinion into contact by turning the preload adjustment screw counterclockwise until a slight resistance is felt and then back the screw off 1/8 of a turn. This step is critical to prepare for preload settings.
5. Place a magnetic base dial indicator on the movable carriage, and locate its probe on the OD of the pinion flange such that it measures in the direction of preload travel.
6. Apply the preload of 0.010 - 0.015 mm [0.0004 - 0.0006 in] with the preload application screw(s) and then tighten the preload lockdown bolts to their recommended torques. See Table 6 for Nexen Preloader System torque values. Typically the preload will change slightly when the preloader lockdown bolts are tightened. If tightening the preload bolts causes the amount of preload to fall outside of specifications record how much it changed when tightening the preloader lock down bolts then loosen the preloading system and repeat the preloading procedure but adjust the initial preload (more or less) by the recorded preload deviation. This procedure will ensure that when the preloader lockdown bolts are tightened the amount of preload should fall within specifications.

7. With the pinion preloaded to specifications manually traverse the carriage down the run by hand (if possible) checking for smoothness and uniformity of resistance. If manually applied motion is not possible, use the servo motor to traverse the carriage along the run, with just enough torque output to move it while looking and listening for resistance to motion.

Table 6

	Screw	Tightening Torque Nm [in-lb]
Preloader Screw		
All Models	-	1.7 [15] Max
Shoulder Screws (Mtg. Plate)		
RPS-PRE-064	M8 x 1.25	40 [350]
RPS-PRE-090	M8 x 1.25	40 [350]
RPS-PRE-110	M8 x 1.25	40 [350]
RPS-PRE-140	M8 x 1.25	40 [350]
RPS-PRE-200	M12 x 1.75	120 [1060]
Gearhead Screws (Mtg. Plate)		
RPS-PRE-064	M4 x 0.7	5.3 [47]
RPS-PRE-090	M5 x 0.8	10 [88]
RPS-PRE-110	M5 x 0.8	10 [88]
RPS-PRE-140	M6 x 1.0	17.5 [155]
RPS-PRE-200	M8 x 1.25	40 [354]
Preloader Mtg. Screws (2x)		
All Models	M6 x 1.0	17.5 [155]

SYSTEM ALIGNMENT VERIFICATION

Proper roller to tooth meshing is critical and can be verified by two methods depending on which you find easier to interpret:

Option 1: Apply a slow drying machinists dye to the pinion rollers and move the RPS system back and forth over a short distance (about 1/2 meter). It is important the dye remain wet so it transfers to the rack teeth and is not depleted. Analyze the dye pattern transferred to the teeth. If the meshing geometry is good the dye will be spread evenly all the way across the tooth face over the middle 2/3 - 3/4 of the teeth with none at the top and bottom. If this section is properly aligned clean off dye residue and repeat as necessary to verify the RPS alignment over the entire length of travel. See Figure 20.

Option 2: Apply a small amount of high contrast grease to each rack tooth face over 1/2 meter of rack. Operate the RPS system back and forth over this 1/2 meter of travel. If the meshing geometry is good the grease will be

completely wiped away all the way across the tooth face over the middle 2/3 - 3/4 of the teeth with some remaining at the top and bottom. If this section is properly aligned clean off grease with a solvent and repeat as necessary to verify the RPS alignment over the entire length of travel as shown in Figure 20.

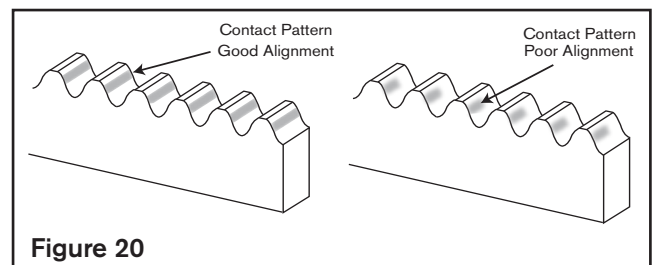



Figure 20

If the dye or grease contact pattern indicates a meshing problem, diagnose the problem, correct it, and then repeat the Applying Preload and System Alignment Verification procedures.

RPS SYSTEM OPERATION



⚠ DANGER
This product has moving parts that can crush or cut appendages. Provide adequate spacing or guarding from any operating product.



⚠ WARNING
Ensure proper guarding of the product is used. Nexen recommends the machine builder design guarding in compliance with OSHA 29 CFR 1910 "Occupational Safety and Health Hazards".



⚠ WARNING
Use appropriate guarding for rotating components. Failure to guard could result in serious bodily injury.



⚠ WARNING
Never exceed maximum operating speeds listed for your product. (See Table 7).

TABLE 7

RPS Maximum Speeds*		
Product	Linear Speed	Pinion RPM
RPS10	4 m/s [13.1 ft/s]	2400
RPS12	8 m/s [26.3 ft/s]	4000
RPS16	4 m/s [13.1 ft/s]	1500
RPS20	5 m/s [16.4 ft/s]	1500
RPS25	8 m/s [26.2 ft/s]	1920
RPS32	11 m/s [36.1 ft/s]	1719
RPS40	6 m/s [19.7 ft/s]	750
RPS4014	6 m/s [19.7 ft/s]	643
RPS50	6 m/s [19.7 ft/s]	600

*Standard RPS speed ratings, specials can vary. Review Nexen specifications for your specific product number.

DISENGAGING THE ROLLER PINION

1. De-couple the load from the RPS system.



⚠ WARNING
Failure to properly support the load before disengaging the RPS system could cause serious harm to operators or equipment.

2. Disconnect the power source, ensuring that no torque is applied to the roller pinion.
3. Remove pinion preload by loosening the preload mechanism sliding bolts slightly and then turning the preload application screw(s) to remove the pinion preload. You should be able to slightly separate the pinion from the rack teeth now.

There are two pinion mounting styles; shaft mount, and flange mount. Proceed to the following section that applies to you.

Shaft Mount Pinion Removal

1. Progressively loosen non-adjacent coupling fasteners in the same order they were tightened until all are removed from the coupling (Refer to Figure 12).
2. Insert the coupling fasteners into the threaded holes in the coupling flange and alternately tighten them as illustrated in Figure 9 to release the locking action of the coupling.
3. Lift the servo/reducer/preload mechanism assembly from the rack or slide the servomotor/reducer out of the pinion bore.
4. Inspect the shaft, and all coupling components and replace any that show excessive wear if the pinion will be reinstalled. Contact Nexen for replacements.

Flange Mount Pinion Removal

1. Remove mounting bolts in an alternating cross pattern.
2. Carefully inspect the mounting bolts and pinion and flange surfaces for any signs of damage and repair or replace as necessary if reinstalling.

LUBRICATION

The pinion needle bearings are sealed and lubricated for life and cannot be serviced.

Nexen recommends lubricating the rack or individual roller contacts every 2 million pinion revolutions or 6 months, whichever ever comes first, but it may need to be lubricated more frequently based on the application conditions, and observable tooth or roller wear.

When lubricating the RPS system inspect the pinion rollers and rack teeth for any abnormal wear patterns and ensure the pinion rollers are not seized or have excessive play. Wear on the edges of the rack teeth (not uniform across the tooth face) or rings on the rollers indicate an alignment problem which should be corrected to obtain maximum system performance and life.

The rollers in new pinions, especially larger sizes, can seem difficult to turn due to seal drag. This improves as the pinion breaks in.

THK AFC is the recommended grease for rack tooth lubrication although THK AFA grease can also be used. Both can be found on the RPS product pages of Nexen's website under accessories. Greases for special applications such as food grade, vacuum, or others are allowed if they use a synthetic base, a polyurea thickener, and meet the following Kinematic Viscosity Levels: CST@40C = 25; CST@100C = 5. Contact Nexen for recommendations on alternative greases.

The RPS system can be lubricated in two ways:

1. Apply grease to the pinion rollers and roll the pinion back and forth 5 times over one meter of rack, repeating the process for each meter of rack.

2. Using a swab apply a very small dab of grease on the middle of each tooth face and roll the pinion back and forth over the entire length of the run 5 times.

Wipe excess grease from the sides of the rack and pinion body to prevent grease being thrown off during operation and for general cleanliness.

Maximum RPS system life will be obtained by following the recommended lubrication intervals as stated above. In some special applications the Premium and Endurance models of RPS rack can be operated lubrication free if the maximum speed does not exceed 0.5 m/s [1.64 ft/s]. Typically lubrication free applications involve:

- Dirty environments where contaminants will be attracted/stick to the lubricant on the rack creating mechanical interference or an abrasive paste that can accelerate wear.
- Food processing
- Clean rooms or applications where very low particle emissions are desired
- Vacuum environments
- Applications where periodic servicing is problematic

If the RPS System is run lubrication free there will be some reduction in life of the RPS system which will vary widely depending on the application. The Standard and Universal models of RPS rack **cannot** be run lubrication free under any circumstances. Contact Nexen for more information.

WARRANTY

Warranties

Nexen warrants that the Products will (a) be free from any defects in material or workmanship for a period of 12 months from the date of shipment, and (b) will meet and perform in accordance with the specifications in any engineering drawing specifically for the Product that is in Nexen's current product catalogue, or that is accessible at the Nexen website, or that is attached to this Quotation and that specifically refers to this Quotation by its number, subject in all cases to any limitations and exclusions set out in the drawing. NEXEN MAKES NO OTHER WARRANTY, EXPRESS OR IMPLIED, AND ALL IMPLIED WARRANTIES, INCLUDING WITHOUT LIMITATION, IMPLIED WARRANTIES OF MERCHANTABILITY AND FITNESS FOR A PARTICULAR PURPOSE ARE HEREBY DISCLAIMED. This warranty applies only if: (a) the Product has been installed, used and maintained in accordance with any applicable Nexen installation or maintenance manual for the Product; (b) the alleged defect is not attributable to normal wear and tear; (c) the Product has not been altered, misused or used for purposes other than those for which it was intended; and (d) Buyer has given written notice of the alleged defect to Nexen, and delivered the allegedly defective Product to Nexen, within one year of the date of shipment.

Exclusive Remedy

The exclusive remedy for the Buyer for any breach of any warranties provided in connection with this agreement will be, at the election of Nexen: (a) repair or replacement with new, serviceably used, or reconditioned parts or products; or (b) issuance of credit in the amount of the purchase price paid to Nexen by the Buyer for the Products.

Agent's Authority

Buyer agrees that no agent, employee or representative of Nexen has authority to bind Nexen to any affirmation, representation, or warranty concerning the Products other than those warranties expressly set forth herein.

Limitation on Nexen's Liability

TO THE EXTENT PERMITTED BY LAW NEXEN SHALL HAVE NO LIABILITY TO BUYER OR ANY OTHER PERSON FOR INCIDENTAL DAMAGES, SPECIAL DAMAGES, CONSEQUENTIAL DAMAGES OR OTHER DAMAGES OF ANY KIND OR NATURE WHATSOEVER, WHETHER ARISING OUT OF BREACH OF WARRANTY OR OTHER BREACH OF CONTRACT, NEGLIGENCE OR OTHER TORT, OR OTHERWISE, EVEN IF NEXEN SHALL HAVE BEEN ADVISED OF THE POSSIBILITY OR LIKELIHOOD OF SUCH POTENTIAL LOSS OR DAMAGE. For all of the purposes hereof, the term "consequential damages" shall include lost profits, penalties, delay damages, liquidated damages or other damages and liabilities which Buyer shall be obligated to pay or which Buyer may incur based upon, related to or arising out of its contracts with its customers or other third parties. In no event shall Nexen be liable for any amount of damages in excess of amounts paid by Buyer for Products or services as to which a breach of contract has been determined to exist. The parties expressly agree that the price for the Products and the services was determined in consideration of the limitation on damages set forth herein and such limitation has been specifically bargained for and constitutes an agreed allocation of risk which shall survive the determination of any court of competent jurisdiction that any remedy herein fails of its essential purpose.

Inspection

Buyer shall inspect all shipments of Products upon arrival and shall notify Nexen in writing, of any shortages or other failures to conform to these terms and conditions which are reasonably discoverable upon arrival without opening any carton or box in which the Products are contained. Such notice shall be sent within 14 days following arrival. All notifications shall be accompanied by packing slips, inspection reports and other documents necessary to support Buyer's claims. In addition to the foregoing obligations, in the event that Buyer receives Products that Buyer did not order, Buyer shall return the erroneously shipped Products to Nexen within thirty (30) days of the date of the invoice for such Products; Nexen will pay reasonable freight charges for the timely return of the erroneously shipped Products, and issue a credit to Buyer for the returned Products at the price Buyer paid for them, including any shipping expenses that Nexen charged Buyer. All shortages, overages and nonconformities not reported to Nexen as required by this section will be deemed waived.

Limitation on Actions

No action, regardless of form, arising out of any transaction to which these terms and conditions are applicable may be brought by the Buyer more than one year after the cause of action has accrued.

nexen

Nexen Group, Inc.
560 Oak Grove Parkway
Vadnais Heights, MN 55127

(800) 843-7445
Fax: (651) 286-1099
www.nexengroup.com

ISO 9001 Certified