



MCH Series Drives LonWorks Communications Guide

About These Instructions

This documentation applies to the use of an MCH Series Variable Frequency Drive with LonWorks protocol and should be used in conjunction with the MCH Series Installation and Operation Manual (Document MH01) that shipped with the drive. These documents should be read in their entirety as they contain important technical data and describe the installation and operation of the drive.

LON®, LonTalk® and LonWorks® are registered trademarks of the Echelon Corporation, San Jose CA 95126, <http://www.echelon.com>; support@echelon.com.

Anybus® and ABS-S® are registered trademarks of HMS Industrial Networks AB, Sweden, USA, Germany and other countries, <http://www.anybus.com>.

Modbus™ is a registered trademark of Schneider Electric, founder of Modbus-IDA, <http://www.modbus-IDA.org>.

© 2003 AC Technology Corporation

No part of this documentation may be copied or made available to third parties without the explicit written approval of AC Technology Corporation. All information given in this documentation has been carefully selected and tested for compliance with the hardware and software described. Nevertheless, discrepancies cannot be ruled out. AC Tech does not accept any responsibility nor liability for damages that may occur. Any necessary corrections will be implemented in subsequent editions.

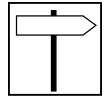

| | | |
|-------|---|----|
| 1 | Safety Information..... | 1 |
| 1.1 | Warnings, Cautions and Notes | 1 |
| 1.1.1 | General | 1 |
| 1.1.2 | Application | 1 |
| 1.1.3 | Installation | 1 |
| 1.1.4 | Electrical Connection..... | 2 |
| 1.1.5 | Operation | 2 |
| 2 | Introduction..... | 3 |
| 2.1 | Hardware Description | 3 |
| 2.2 | LED Status Indicators..... | 4 |
| 2.3 | Serial Communications Wiring | 5 |
| 3 | Drive Setup and Programming..... | 6 |
| 3.1 | Added Programming Parameters | 6 |
| 3.2 | Bus Configuration Parameters..... | 7 |
| 3.3 | Omitted Parameters and Selections | 9 |
| 3.4 | Modified Parameters and Selections | 9 |
| 3.5 | Serial Communication Setup..... | 10 |
| 4 | MCH LonWorks® Network Variables | 12 |
| 4.1 | LonWorks® Network Variable Map | 12 |
| 4.2 | Supported Input Network Variables | 13 |
| 4.3 | Supported Output Network Variables..... | 15 |
| 4.4 | Supported Configuration Network Variables | 19 |
| 4.5 | LonWorks XIF Files | 23 |



1 Safety Information

1.1 Warnings, Cautions and Notes

1.1.1 General

Some parts of Lenze controllers (frequency inverters, servo inverters, DC controllers) can be live, moving and rotating. Some surfaces can be hot.

Non-authorized removal of the required cover, inappropriate use, and incorrect installation or operation creates the risk of severe injury to personnel or damage to equipment.

All operations concerning transport, installation, and commissioning as well as maintenance must be carried out by qualified, skilled personnel (IEC 364 and CENELEC HD 384 or DIN VDE 0100 and IEC report 664 or DIN VDE0110 and national regulations for the prevention of accidents must be observed).

According to this basic safety information, qualified skilled personnel are persons who are familiar with the installation, assembly, commissioning, and operation of the product and who have the qualifications necessary for their occupation.

1.1.2 Application

Drive controllers are components designed for installation in electrical systems or machinery. They are not to be used as appliances. They are intended exclusively for professional and commercial purposes according to EN 61000-3-2. The documentation includes information on compliance with EN 61000-3-2.

When installing the drive controllers in machines, commissioning (i.e. the starting of operation as directed) is prohibited until it is proven that the machine complies with the regulations of the EC Directive 98/37/EC (Machinery Directive); EN 60204 must be observed.

Commissioning (i.e. starting drive as directed) is only allowed when there is compliance to the EMC Directive (89/336/EEC).

The drive controllers meet the requirements of the Low Voltage Directive 73/23/EEC. The harmonised standards of the series EN 50178/DIN VDE 0160 apply to the controllers.

The availability of controllers is restricted according to EN 61800-3. These products can cause radio interference in residential areas. In the case of radio interference, special measures may be necessary for drive controllers.

1.1.3 Installation

Ensure proper handling and avoid excessive mechanical stress. Do not bend any components and do not change any insulation distances during transport or handling. Do not touch any electronic components and contacts. Controllers contain electrostatically sensitive components, which can easily be damaged by inappropriate handling. Do not damage or destroy any electrical components since this might endanger your health! When installing the drive ensure optimal airflow by observing all clearance distances in the drive's user manual. Do not expose the drive to excessive: vibration, temperature, humidity, sunlight, dust, pollutants, corrosive chemicals or other hazardous environments.



Safety Information

1.1.4 Electrical Connection

When working on live drive controllers, applicable national regulations for the prevention of accidents (e.g. VBG 4) must be observed.

The electrical installation must be carried out in accordance with the appropriate regulations (e.g. cable cross-sections, fuses, PE connection). Additional information can be obtained from the regulatory documentation.

The regulatory documentation contains information about installation in compliance with EMC (shielding, grounding, filters and cables). These notes must also be observed for CE-marked controllers.

The manufacturer of the system or machine is responsible for compliance with the required limit values demanded by EMC legislation.

1.1.5 Operation

Systems including controllers must be equipped with additional monitoring and protection devices according to the corresponding standards (e.g. technical equipment, regulations for prevention of accidents, etc.). You are allowed to adapt the controller to your application as described in the documentation.



DANGER!

- After the controller has been disconnected from the supply voltage, do not touch the live components and power connection until the capacitors have discharged. Please observe the corresponding notes on the controller.
- Do not continuously cycle input power to the controller more than once every three minutes.
- Close all protective covers and doors during operation.



WARNING!

Network control permits automatic starting and stopping of the inverter drive. The system design must incorporate adequate protection to prevent personnel from accessing moving equipment while power is applied to the drive system.

Table 1: Pictographs used in these instructions

| Pictograph | Signal word | Meaning | Consequences if ignored |
|------------|-----------------|--|--|
| | DANGER! | Warning of Hazardous Electrical Voltage. | Reference to an imminent danger that may result in death or serious personal injury if the corresponding measures are not taken. |
| | WARNING! | Impending or possible danger for persons | Death or injury |
| | STOP! | Possible damage to equipment | Damage to drive system or its surroundings |
| | NOTE | Useful tip: If observed, it will make using the drive easier | |



2 Introduction

This document explains how to connect an MCH Drive to a LonWorks® network. It is intended as a serial communications supplement only and will not discuss normal drive operations. For more information regarding normal drive setup and functionality, refer to the MCH Installation and Operation Manual (MH01).

LonWorks® technology is a complete platform for implementing control network systems. These networks consist of intelligent control devices or nodes that interact with their environment and communicate with each other using a common, message based protocol (LonTalk®). A LonWorks® network can consist of up to 32,385 nodes divided into 255 subnets (127 nodes/subnet).

2.1 Hardware Description

To connect to a LonWorks® network, the MCH Drive utilizes an Anybus-S® Drive Profile Embedded Interface Card that supports Version 1.1 of the LonMark® 6010 Functional Profile for Variable Speed Motor Drives. This Anybus-S LonWorks (ABS-LON®) module is located inside of the bypass or option box that is attached to the MCH Drive.

The ABS-LON® module communicates according to the LonTalk® protocol. This means that it can communicate with all LonWorks® nodes that comply with this protocol, but it does not necessarily mean that all services available in the LonTalk® protocol are supported.

The ABS-LON® module uses the FTT-10A (Free Topology Twisted Pair) transceiver from Echelon Corporation. This is the most commonly used twisted-pair media in building automation and this architecture supports star, bus and loop wiring. The FTT-10A transceiver connects to a twisted pair cable with a baud rate of 78 kbit/s. The FTT-10A transceiver appears as a high impedance to the network when unpowered, and does not interfere with network communications when powered down.

Figure 1 identifies the components of the communications module intended for user interaction.

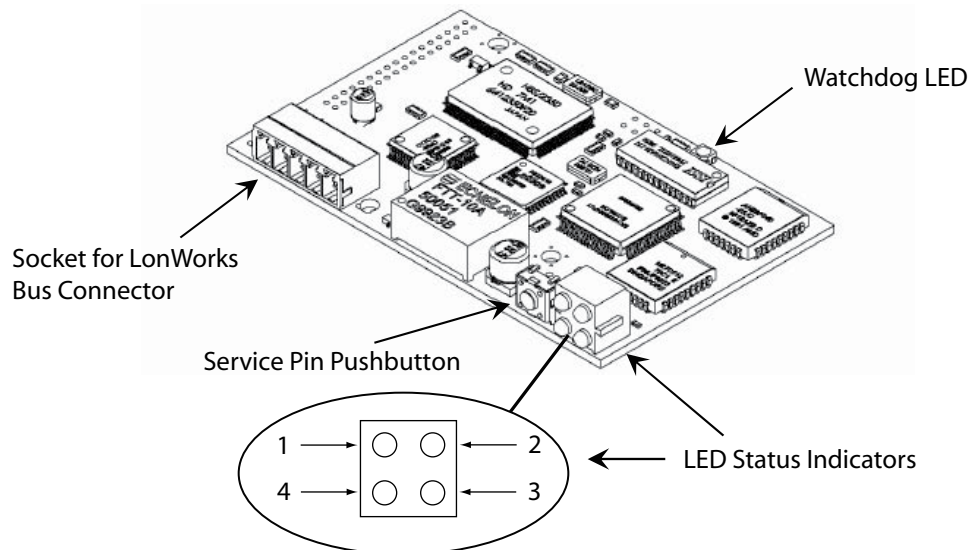
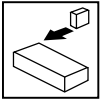

Figure 1: MCH LonWorks® Comm Module



Drive Setup & Programming

2.2 LED Status Indicators

LED 1 - Drive Communication

This LED indicates the communication status between the comm module and the drive.

| LED State | Indicates: |
|--------------|----------------------|
| Steady Green | Link OK |
| Steady Red | Link lost, permanent |
| Flashing Red | Link lost, temporary |

LED 2 - Service

This LED indicates the node configuration and application status.

| LED State | Indicates: |
|----------------|---|
| Steady OFF | Node configured and installed in network |
| Steady Green | Node not configured, has no application; Error detected by Neuron Self Test routine |
| Flashing Green | Node not configured and not installed in network but node has an application |

LED 3 - Wink

This LED indicates receipt of a wink command.

| LED State | Indicates: |
|--------------|--|
| Flashing Red | Wink command received on LonWorks® network |
| Steady OFF | Normal state |

LED 4 - Network Status

This LED indicates the communication status between the module and the LonWorks® network.

| LED State | Indicates: |
|--------------|--|
| Steady OFF | No power |
| Flashing Red | Receive heartbeat timeout occurred; Fieldbus communication loss indicated to host: RX_FAIL |
| Steady Green | Module and network are communicating correctly |

Watchdog LED (WD)

This LED indicates module, drive and software status.

| LED State | Indicates: |
|--------------------|---|
| Flashing Green 1Hz | Module initialized and running properly |
| Flashing Green 2Hz | Module not initialized |
| Flashing Red 1Hz | Hardware check fault |
| Flashing Red 4Hz | Drive initialization failed |
| Steady Orange | Software download enabled |

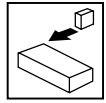

2.3 Serial Communications Wiring

Figure 2 illustrates one method of wiring the MCH Series LonWorks® Bus Connector with an optional switch to provide remote operation of the service pin.

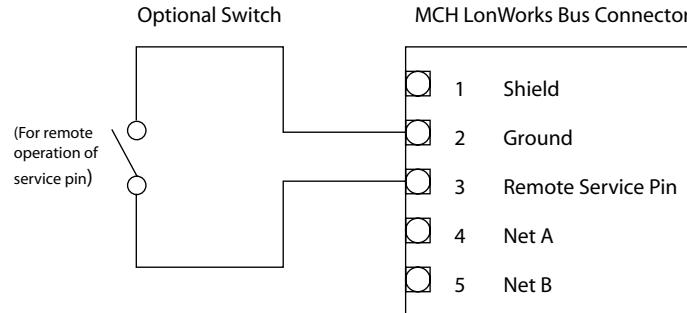
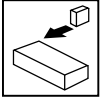

Figure 2: Wiring the MCH LonWorks® Bus Connector

- Net A, Net B** This is the 2-wire LonWorks bus designed according to the LonMark® design guidelines. The bus is of non-polarization character and supports line-powered networks.
- Service Pin** This pin is used for the (optional) remote functionality of the Service Pin pushbutton. Refer to Figure 2 for an illustration on how to wire this.
- Ground** This pin is used for the remote Service Pin functionality. Refer to Figure 2.
- Shield** This pin should be connected to the shield of the LonWorks cable, in cases where such cable is to be used. The pin is connected to the Ground terminal (2) on the communications module through an RC-filter.



Drive Setup & Programming

3 Drive Setup and Programming

Most drive parameters (including those required for serial communications) are not accessible through the LonWorks® interface. They can only be accessed by entering the Programming Mode of the drive itself. Refer to the MCH Installation and Operation Manual (MH01) for more information. The parameter information in manual MH01 is based on the standard MCH Series Modbus™ Drive. The differences between the drive programming parameters described in the manual and those that exist in the MCH Series LonWorks® Drive are explained in sections 3.1-3.4 herein.

3.1 Added Programming Parameters

- | | |
|--------------------------|---|
| 60 SERIAL TIMEOUT | This parameter makes the serial watchdog timeout period selectable. (Section 3.5) |
| 86 MOTOR RATED SPEED | This parameter allows the user to enter the nominal speed of the motor in RPM. This value is required for LON parameter nvoSpeedActRpm to function properly. This parameter has a minimum value of 1 RPM and a maximum value of 65000 RPM. The default is 1800 RPM. |
| 89 MOTOR RATED FREQUENCY | This parameter allows the user to enter the nominal frequency of the motor in Hz. This value is required for many LON parameters (including nviDrvSpeedStpt and nvoDrvSpeed) to function properly. This parameter has a minimum value of 0.00 Hz and a maximum value of 650.00 Hz. The default is 60.00 Hz. |
| 125 APP REVISION | This parameter allows the user to view the version of the application software installed in the ABS_LON module. This parameter is used for troubleshooting and to establish compatibility between the drive software and the ABS_LON module. If this parameter is displaying a value of 0104 or 9999, contact AC Tech. |
| 126 CPI REVISION | This parameter allows the user to view the version of the common profile interface software installed in the ABS_LON module. This parameter is used for troubleshooting and to establish compatibility between the drive software and the ABS_LON module. If this parameter is displaying a value of 0124 or 9999, contact AC Tech. |
| 127 CFG REVISION | This parameter allows the user to view the version of the AC Tech configuration software installed in the ABS_LON module. This parameter is used for troubleshooting and to establish compatibility between the drive software and the ABS_LON module. If this parameter is displaying a value of 0001 or 9999, contact AC Tech. |

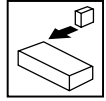

3.2 Bus Configuration Parameters

The Bus configuration parameters are only used to provide additional information about the installation state of the drive. As the address information usually is assigned from the network side in a LonWorks network, in the programming mode of the drive, these parameters are read-only.

100 NODE STATE This parameter contains the current state of the network interface. Configured Online is the normal run-time mode and means that the drive is commissioned and online. Soft/Bypass/Hard Offline means the node is not participating actively on the network.

| Value | Node State |
|-------|------------------------------|
| 0 | Unknown State |
| 1 | Unconfigured |
| 2 | Applicationless |
| 3 | Configured Online |
| 4 | Configured Offline |
| 5 | Soft Offline |
| 6 | Configured Bypass Offline |
| 7 | Hard Offline, Bypass Offline |

- 101 NEURON ID [5]** Byte 6 of the unique Neuron ID (MSB)
- 102 NEURON ID [4]** Byte 5 of the unique Neuron ID
- 103 NEURON ID [3]** Byte 4 of the unique Neuron ID
- 104 NEURON ID [2]** Byte 3 of the unique Neuron ID
- 105 NEURON ID [1]** Byte 2 of the unique Neuron ID
- 106 NEURON ID [0]** Byte 1 of the unique Neuron ID (LSB)
- 107 NODE ADDRESS 1** Indicates the ID of the node within this subnet. A value of 0 means that it is not assigned.
- 108 NODE SUBNET 1** Indicates to which subnet this node belongs. A value of 0 means that it is not assigned.

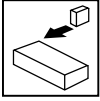

Drive Setup & Programming

Each domain in a LonWorks network has a unique ID of 0, 1, 3 or 6 bytes in length. If the ID is shorter than 6 bytes, it is left justified in the following parameters (109-114).

| | |
|---------------------|--|
| 109 DOMAIN ID 1 [5] | Byte 6 of the domain ID (MSB) |
| 110 DOMAIN ID 1 [4] | Byte 5 of the domain ID |
| 111 DOMAIN ID 1 [3] | Byte 4 of the domain ID |
| 112 DOMAIN ID 1 [2] | Byte 3 of the domain ID |
| 113 DOMAIN ID 1 [1] | Byte 2 of the domain ID |
| 114 DOMAIN ID 1 [0] | Byte 1 of the domain ID (LSB) |
| 115 NODE ADDRESS 2 | Indicates the ID of the node within this subnet. A value of 0 means that it is not assigned. |
| 116 NODE SUBNET 2 | Indicates to which subnet this node belongs. A value of 0 means that it is not assigned. |

Each domain in a LonWorks network has a unique ID of 0,1,3 or 6 bytes in length. If the ID is shorter than 6 bytes, it is left justified in the following parameters (117-122).

| | |
|---------------------|---|
| 117 DOMAIN ID 2 [5] | Byte 6 of the domain ID (MSB) |
| 118 DOMAIN ID 2 [4] | Byte 5 of the domain ID |
| 119 DOMAIN ID 2 [3] | Byte 4 of the domain ID |
| 120 DOMAIN ID 2 [2] | Byte 3 of the domain ID |
| 121 DOMAIN ID 2 [1] | Byte 2 of the domain ID |
| 122 DOMAIN ID 2 [0] | Byte 1 of the domain ID (LSB) |
| 123 XMIT ERRORS | The number of CRC errors detected during packet reception. These may be due to collisions or noise on the transceiver input. |
| 124 TRANS TIMEOUTS | The number of times that the node failed to receive expected acknowledgements or responses after retrying the configured number of times. These may be due to destination nodes being inaccessible on the network, transmission failures because of noise on the channel, or if any destination node has insufficient buffers or receive transaction records. |

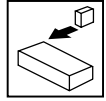

3.3 Omitted Parameters and Selections

| | |
|------------------------|--|
| 36 SLEEP THRESHOLD | Sleep Mode functionality has not been added to the MCH Series LonWorks® drive so these drive parameters do not exist. |
| 37 SLEEP DELAY | |
| 38 SLEEP BANDWIDTH | |
| 41 ANALOG INPUT FILTER | |
| 52 TB14 OUT | The following options have not been added to these parameters in the MCH Series LonWorks® drive: |
| 53 TB15 OUT | |
| 54 RELAY | |
| | |
| | INV MIN/MAX A |
| | MIN ALARM |
| | INV MIN ALARM |
| | MAX ALARM |
| | INV MAX ALARM |
| 58 SERIAL ADDRESS | The ABS_LON module only communicates with one MCH Drive so there is no need for the drive to have a unique serial address and this parameter has been removed. |

3.4 Modified Parameters and Selections

| | |
|------------------|--|
| 8 ACCEL | This parameter defines the time that it will take for the drive to ramp the motor up from 0.00Hz to Drive Parameter #11 (Max Frequency). |
| 9 DECEL | This parameter defines the time that it will take for the drive to ramp the motor down from Drive Parameter #11 (Max Frequency) to 0.00Hz. |
| 24 AUTO SOURCE | The default selection for this parameter is KEYPAD. This setting is required if the drive speed is to be modified over the LonWorks® network. |
| 32 HZ MULTIPLIER | The default setting for this parameter is 30.00. |
| 56 SERIAL LOSS | The selections for this parameter are FAULT (default) and PRESET#3. The functionality of this parameter is described in Section 3.5 Serial Communications Setup. |

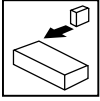

Drive Setup & Programming

3.5 Serial Communication Setup

The factory default values of the drive parameters have been set to allow immediate serial communications (without serial stop/start and serial speed commands). For serial speed and/or serial start/stop control, modify the setting of Drive Parameter #30 (Control). The drive parameters that are required for serial communications, including Drive Parameter #30, are described herein.

| | |
|----------------|--|
| 24 AUTO SOURCE | This parameter must be set to KEYPAD for the drive speed or setpoint to be modified over the network. |
| 30 CONTROL | This parameter should be set to accommodate the specific application intent: NORMAL Serial start/stop and serial speed commands are invalid. NORM NO HAND Same as NORMAL except the HAND/OFF/AUTO, herein referred to as H/O/A, is limited to settings of OFF and AUTO. SERIAL SPEED Serial start commands are invalid. Serial speed commands are valid in AUTO. S SPD/NO HAND Same as SERIAL SPEED except H/O/A is limited to settings of OFF and AUTO. SERIAL AUTO Serial start/stop and serial speed commands are valid in AUTO. This setting forces the drive to be started via the serial link when in AUTO. S AUTO/NO HND Same as SERIAL AUTO except H/O/A is limited to settings of OFF and AUTO. |

The STOP command issued when LonWorks (LON) parameter nviEmrgOvrdr is set to EMERG_SHUTDOWN is accepted regardless of the H/O/A switch position.

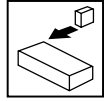

- 56 SERIAL LOSS** This parameter sets the action to be taken in the event that the LON has modified the speed command or started the drive and a serial watchdog timeout occurs. The options for this parameter are FAULT (default) and PRESET#3.
- If FAULT is selected and the drive is running when a serial watchdog timeout occurs the drive will trip into a SERIAL FAULT stopping the drive and taking it out of serial control. A fault reset command (issued via LON parameter nviResetFault), a keypad stop or a terminal stop is required to clear the fault.
- If PRESET#3 is selected and a timeout occurs the drive will continue to run at the speed defined in Drive Parameter #3 (PRESET #3). If the drive is stopped (KSTOP, RSTOP, SSTOP or FAULT) or a valid speed command is received from the LON, the drive will return to its normal speed reference.
- When Drive Parameter #30 (CONTROL) is set to SERIAL SPEED, the speed reference MUST be the drive keypad (-KEY or -MKB) for the serial loss action to take effect. When CONTROL is set to SERIAL AUTO the serial loss action will take effect with any speed reference.
- This parameter also defines the action to be taken in the event that the drive is placed OFFLINE or a Receive Heartbeat timeout (RX_FAIL) occurs.
- 57 SERIAL** This parameter needs to be set to either WITH TIMER (default) or W/O TIMER for the drive to communicate through the serial link. Serial communications will not work if this parameter is set to DISABLED.
- 60 SERIAL TIMEOUT** This parameter makes the serial watchdog timeout period selectable. It has a minimum value of 10 seconds and maximum value of 255 seconds. The default is 30 seconds. If no action is to be taken when a serial watchdog timeout occurs, Drive Parameter #57 (Serial) should be set to W/O TIMER. This will disable the watchdog timer. Otherwise Drive Parameter #57 (Serial) should be set to WITH TIMER. The action to be taken when a timeout occurs is then determined by Drive Parameter #56 (Serial Loss).
- NOTE:** Receive heartbeat timeouts and OFFLINE occurrences are not affected by the setting of Parameter 60.

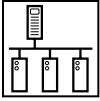

LonWorks Network Variables

4 MCH LonWorks® Network Variables

The MCH LonWorks® Network Variables (nv) are divided into three types: input, output and configuration. Sections 4.2 - 4.5 describe each of these variable types and the individual supported variables within each.

4.1 LonWorks® Network Variable Map

Figure 3 is a visual map of the supported LonWorks® network variables for the MCH Series drive.

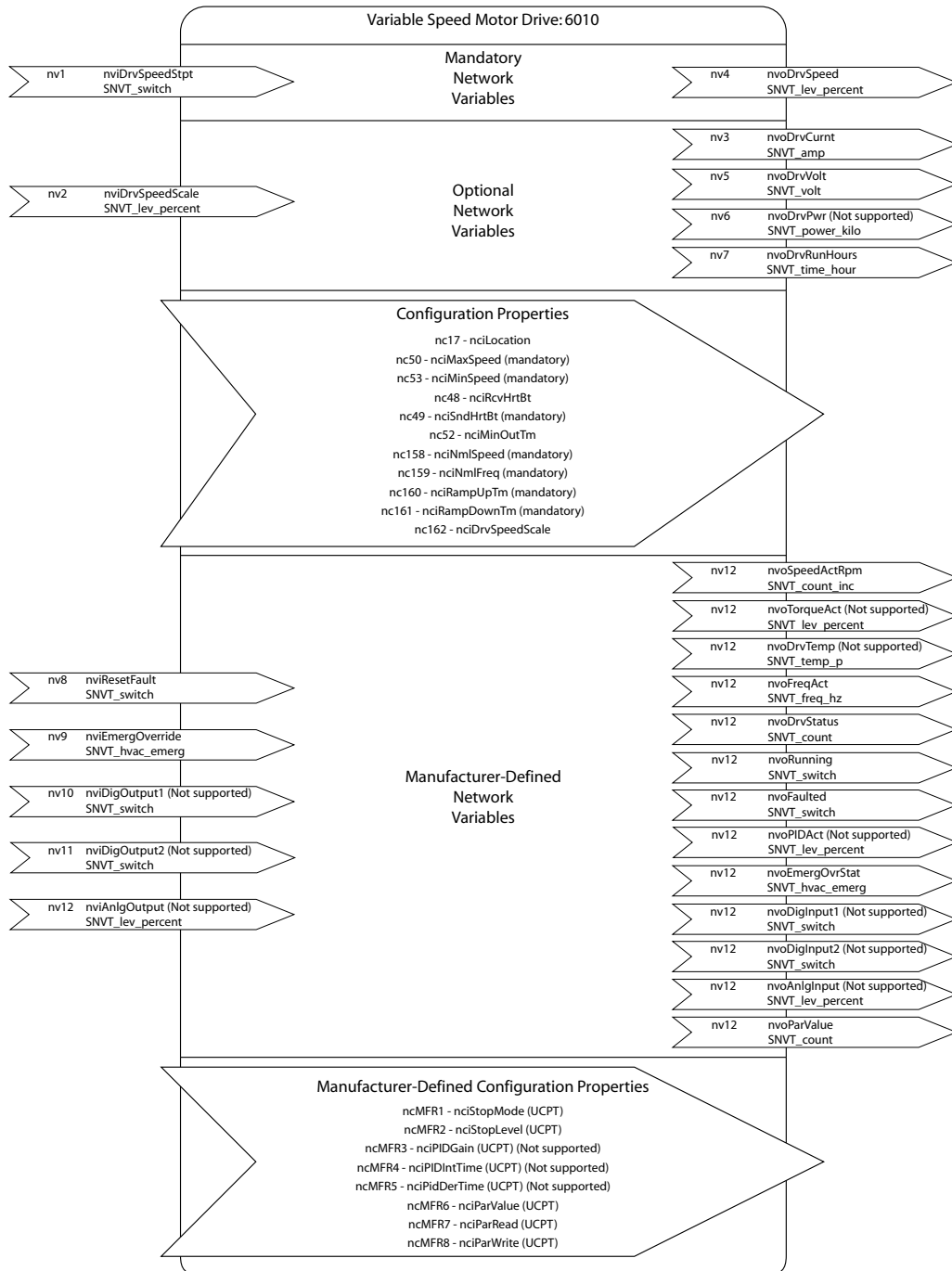
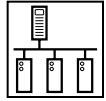

Figure 3: LonWorks® Network Variable Map for MCH Series Drives



4.2 Supported Input Network Variables

NviObjRequest

Definition Network input SNVT_obj_request nviObjRequest;

Explanation This input is used to enable control commands and updates from the network. The status of the node is reported in nvoObjStatus.

Valid range:

| Object Request | Function |
|------------------|---|
| RQ_UPDATE_STATUS | Updates nvoObjStatus |
| RQ_CLEAR_STATUS | Clears nvoObjStatus |
| RQ_CLEAR_ALARM | Resets a drive fault |
| RQ_REPORT_MASK | Reports supported requests in nvoObjStatus |
| RQ_NORMAL | The normal request. Sets object to default state |
| RQ_DISABLE | Stops the drive with the selected stop mode and disables the operation and object |
| RQ_ENABLE | Enables the drive for operation and enables the object |

Commands not listed above will be reported as invalid_request in nvoObjStatus.

NviDrvSpeedStpt

Definition Network input SNVT_switch nviDrvSpeedStpt.

Explanation This input network variable provides a low-resolution speed setpoint. It may also use the receive heartbeat function. The speed setpoint is the result of multiplication of nviDrvSpeedStpt and nviDrvSpeedScl.

Valid Range:

| State | Valid Range |
|-----------|-----------------|
| 0 | Stop the drive |
| 1 | Start the drive |
| -1 (0xff) | Auto (Invalid) |

| Value (% Nominal) | Internal Value |
|-------------------|----------------|
| -100.0% to -0.5% | -200 to -1 |
| 0.0% | 0 |
| 0.5% to 100.0% | 1 to 200 |

Default value The default value is AUTO (state = 0xFF). This value will be adopted at power-up. This network variable input may use the Receive Heartbeat function if the Receive Heartbeat function is setup for use. The actual value of drive speed also depends on the setting of nviDrvSpdScl.

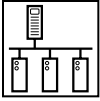

LonWorks Network Variables

NviDrvSpdScl

- Definition** Network input SNVT_lev_percent nviDrvSpeedScale
- Explanation** This input network variable provides scaling for nviDrvSpeedStpt (0.005% resolution).
- For example, if the value of nviDrvSpeedStpt is 100% and nviDrvSpdScl value is 150%, then the actual speed setpoint value is 150% meaning that the drive should run at 1.5 times nominal speed in the forward direction. A negative value for nviDrvSpdScl sets the drive direction to reverse.
- For example if nviDrvSpeedStpt value is 100% and nviDrvSpdScl value is -150%, then actual speed setpoint value is -150%, meaning that the drive should run at 1.5 times nominal speed in the reverse direction.
- Valid Range** -163.840% to 0.00 % or 0.00% to +163.835%
The value 0x7FFF represents invalid data.
- Default Value** Defined by nciDrvSpdScl.

NviResetFault

- Definition** Network input SNVT_switch nviResetFault
- Explanation** This input network variable provides a mechanism to clear a fault status in the drive.

Valid Range:

| State | Value | Command |
|-------|--------|-------------------|
| 0 | 0.0% | Reset Fault Ready |
| 1 | 100.0% | Reset Fault |

On a transition from 0 to 1, this input network variable clears the fault condition in the drive. Following a fault reset, this variable must be set back to 0 to enable the next fault reset.

- Default Value** The drive will power-up in the 'Reset Fault Ready' state.

LonWorks Network Variables

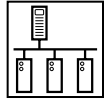

NviEmrgOvr

- Definition Network input SNVT_hvac_emerg nviEmrgOvr
- Explanation HVAC Emergency Mode. This input network variable provides the ability to stop the motor in case of an emergency.
- Valid Range:

| Setting | Function |
|--------------------|---|
| EMERG_NORMAL | Not emergency mode, motor control enabled |
| EMERG_PRESSURIZE | No functionality in this implementation |
| EMERG_DEPRESSURIZE | No functionality in this implementation |
| EMERG_PURGE | No functionality in this implementation |
| EMERG_SHUTDOWN | Emergency shutdown mode. Stops motor |
| EMERG_FIRE | No functionality in this implementation |
| EMERG_NUL | Value not available |

Default Value EMERG_NORMAL

4.3 Supported Output Network Variables

NvoObjStatus

- Definition Network output SNVT_obj_status nvoObjStatus
- Explanation This nvo reports the node object status.
- Valid Range:

| Bit Setting | Function |
|----------------------|---|
| Invalid_id | Invalid node ID requested |
| report_mask | Reporting supported fields |
| Disabled (20) | RQ_DISABLED is active |
| electrical_fault (5) | Same as the faulted bit in nvoDrvStatus |
| In_alarm | Same as the alarm bit in nvoDrvStatus |

NvoDrvSpeed

- Definition Network output SNVT_lev_percent nvoDrvSpeed
- Explanation This output network variable provides the speed of the drive as a percentage of the nominal speed.
- Valid Range -163.830% to 0.000 % or 0.000% to +163.830%.
The value 0x7FFF represents invalid data.
- Default Value 0.000%.

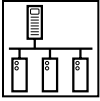

LonWorks Network Variables

NvoDrvCurnt

NOTE: This parameter is not supported in drives with software version MC11101 or MC11102.

Definition Network output SNVT_amp nvoDrvCurnt

Explanation This output network variable provides the drive output current in Amps.

Valid Range 0.0 to 3276.7 A

Default Value 0.0 A

NvoDrvRunHours

NOTE: This parameter is not supported in drives with software version MC11101 or MC11102.

Definition Network output SNVT_time_hour nvoDrvRunHours

Explanation This output network variable provides total operation time of the motor in hours.

Valid Range 0 to 65535 hours

Default Value 0 hours

NvoDrvVolt

NOTE: This parameter is not supported in drives with software version MC11101 or MC11102.

Definition Network output SNVT_volt nvoDrvVolt

Explanation This output network variable provides the drive output voltage in Volts.

Valid Range 0 – 700 V

Default Value 0 V

NvoSpeedActRpm

Definition Network output SNVT_count_inc nvoSpeedActRpm

Explanation This output network variable provides the speed of the drive in RPM's

Valid Range -32768 to 0 or 0 to 32767

Default Value 0 RPM

LonWorks Network Variables

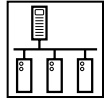

NvoFreqAct

| | |
|---------------|---|
| Definition | Network output SNVT_freq_hz nvoFreqAct |
| Explanation | This output network variable provides the speed of the drive in Hz. |
| Valid Range | 0.0 - 120.00 Hz |
| Default Value | 0.00 Hz |

NvoDrvStatus

| | |
|-------------|--|
| Definition | Network output SNVT_state nvoDrvStatus |
| Explanation | This output network variable provides the status of the drive. |
| Valid Range | |

| Bit | Name | Description |
|-------|------------|---|
| 0 | FWD | The drive is currently running the motor in forward motion |
| 1 | REV | The drive is currently running the motor in reverse motion |
| 2 | NETCTRL | The network is the active source for start/stop control |
| 3 | NETREF | The network is the active source for the speed reference |
| 4 | RTSO | Not used |
| 5 | FAULT | The drive is currently faulted |
| 6 | ALARM | Not used |
| 7 | REF | The drive is running the motor at the speed defined by the speed reference of the active control source (i.e. actual drive speed = commanded drive speed) |
| 8 | FORN | Not used |
| 9 | ZERO SPEED | The drive is running at zero speed |
| 10 | LIMIT | Not used |
| 11 | ACC | The drive is currently ramping up to its commanded speed |
| 12 | DEC | The drive is currently ramping down to its commanded speed |
| 13-15 | Not used | Not used |

Default Value 0

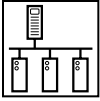

LonWorks Network Variables

NvoRunning

Definition Network output SNVT_switch nvoRunning
Explanation This output indicates whether or not the motor is running.
Valid Range:

| State | Value | Command |
|-------|--------|--------------------------|
| 0 | 0.0% | The motor is not running |
| 1 | 100.0% | The motor is running |

Default Value 0

NvoFaulted

Definition Network output SNVT_switch nvoFaulted
Explanation This output indicates whether or not the drive is currently faulted.
Valid Range:

| State | Value | Command |
|-------|--------|--------------------------|
| 0 | 0.0% | The drive is not faulted |
| 1 | 100.0% | The drive is faulted |

Default Value 0

NvoEmrgOvr Stat

Definition Network output SNVT_hvac_emerg nvoEmrgOvrStat
Explanation Feedback for the nviEmrgOvr
Valid Range:

| Value | Function |
|----------------|---|
| EMERG_NORMAL | Not emergency mode, motor control enabled |
| EMERG_SHUTDOWN | Emergency shutdown mode. Motor stopped. |

Default Value EMERG_NORMAL

NvoParValue

Definition Network output SNVT_count nvoParValue
Explanation This variable contains the data read at the parameter set by nciParRead.
Valid Range 1 - 46
Default Value 0

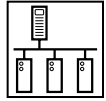

4.4 Supported Configuration Network Variables

NciSndHrtBt

| | |
|---------------|--|
| Definition | Network config input SNVT_time_sec nciSndHrtBt |
| Explanation | This input configuration network variable provides the maximum send time for the variable nvoDrvSpeed. |
| Valid Range | 0.0 to 6553.5 sec The value 0 disables the Send Heartbeat mechanism. The value 0xFFFF represents invalid data. |
| Default Value | 0 sec (disabled) |

NciRcvHrtBt

| | |
|---------------|---|
| Definition | Network config input SNVT_time_sec nciRcvHrtBt |
| Explanation | This configuration property is used to control the maximum time that elapses after the last update to input network variables nviDrvSpeedStpt or nviDrvSpdScI. If a timeout occurs, the module indicates an RX_FAIL condition to the drive which induces the Serial Loss action described in Section 3.5. |
| Valid Range | 0.0 to 6553.5 sec The value 0xFFFF represents invalid data. The value 0 disables the Receive Heartbeat mechanism. |
| Default Value | 0 sec (disabled) |

NciMinOutTm

| | |
|---------------|--|
| Definition | Network config input SNVT_time_sec nciMinOutTm |
| Explanation | This input configuration network variable controls the minimum period of time that expires before the network output variables can be propagated (resent). |
| Valid Range | 0.0 to 6553.5 sec The value 0xFFFF represents invalid data. The value 0 disables transmission limiting. |
| Default Value | 0.0 sec (disabled) |

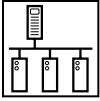

LonWorks Network Variables

nciNmISpeed

| | |
|---------------|--|
| Definition | Network config input SNVT_rpm nciNmISpeed |
| Explanation | This configuration property is used to provide the nominal speed of the motor. |
| Valid Range | 1 to 65000 RPM The value 0xFFFF represents invalid data. |
| Default Value | 1800 RPM |

nciNmIFreq

| | |
|---------------|--|
| Definition | Network config input SNVT_freq_hz nciNmIFreq |
| Explanation | This configuration property is used to provide the nominal frequency of the motor. |
| Valid Range | 0.0 - 650.00 Hz |
| Default Value | 60.00 Hz |

nciMinSpeed

| | |
|---------------|--|
| Definition | Network config input SNVT_lev_percent nciMinSpeed |
| Explanation | This configuration property is used to define the minimum speed of a motor. Its value is entered as a percentage of nominal speed, as defined by the Nominal Speed (nciNmISpeed) configuration value. The value of the minimum speed must be validated against the value of the maximum speed as follows: $-163.840\% \leq \text{minimum speed} \leq \text{maximum speed} \leq 163.835\%$ |
| Valid Range | -163.840% to 0.000 % or 0.000% to +163.835% The value 0x7FFF represents invalid data. |
| Default Value | 0.830% |

nciMaxSpeed

| | |
|---------------|---|
| Definition | Network config input SNVT_lev_percent nciMaxSpeed |
| Explanation | This configuration property is used to define the maximum speed of a motor. Its value is entered as a percent of nominal speed, as defined by the Nominal Speed (nciNmISpeed) configuration value. The value of the maximum speed must be validated against the value of the minimum speed as follows: $-163.840\% \leq \text{minimum speed} \leq \text{maximum speed} \leq 163.835\%$ |
| Valid Range | -163.840% to 0.000 % or 0.000% to +163.835% The value 0x7FFF represents invalid data. |
| Default Value | 100.000% |

LonWorks Network Variables

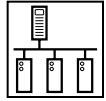

nciRampUpTm

| | |
|---------------|--|
| Definition | Network config input SNVT_time_sec nciRampUpTm |
| Explanation | This configuration property is used to set the ramp up time of the drive (i.e. the time that it will take for the drive to ramp the motor from 0.00Hz to Max Frequency). |
| Valid Range | 0.1 to 3600.0 sec (Refer to MCH Installation and Operation Manual for the actual minimum boundary) The value 0xFFFF represents invalid data. |
| Default Value | 30.0 sec |

nciRampDownTm

| | |
|---------------|--|
| Definition | Network config input SNVT_time_sec nciRampDownTm |
| Explanation | This configuration property is used to set the ramp down time of the drive (i.e. the time that it will take for the drive to ramp the motor from Max Frequency to 0.00Hz). |
| Valid Range | 0.3 to 3600.0 sec (Refer to MCH Installation and Operation Manual for the actual minimum boundary) The value 0xFFFF represents invalid data. |
| Default Value | 30.0 sec |

nciLocation

| | |
|---------------|--|
| Definition | Network config input SNVT_str_asc nciLocation |
| Explanation | This configuration property can optionally be used to provide more descriptive physical location information than can be provided by the Neuron Chip's 6-byte location string. The location relates to the object and not to the node. |
| Valid Range | 31 characters |
| Default Value | Empty spaces |

nciDrvSpdScl

| | |
|---------------|--|
| Definition | Network config input SNVT_lev_percent nciDrvSpeedScale |
| Explanation | Default value for nviDrvSpdScl. |
| Valid Range | -163.840% to 0.000 % or 0.000% to +163.835% The value 0x7FFF represents invalid data. |
| Default Value | 100.000% |

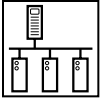

LonWorks Network Variables

nciStopMode

Definition Network config input SNVT_switch nciStopMode

Explanation This input network variable is used to choose between coast and ramp stop.

Valid Range:

| State | Value | Command |
|-------|--------|---------------|
| 0 | 0.0% | Coast to stop |
| 1 | 100.0% | Ramp to stop |

Default Value 0

nciStopLevel

Definition Network config input SNVT_lev_percent nciStopLevel

Explanation This is the stop level for the drive when it is in ramp to stop mode. When the drive is ramping to a stop and reaches this level, a coast to stop is performed. The value is relative to nvoDrvSpeed (i.e. a value of 5% corresponds to a nvoDrvSpeed value of 5%).

Valid Range -163.840% to 0.00 % or 0.00% to +163.835%
The value 0x7FFF represents invalid data.

Default Value 5.000 %

nciParValue

Definition Network config input SNVT_count_inc nciParValue

Explanation This nci is used as a value input for the user selected parameter nciParWrite.

Valid Range 1 - 46

Default Value 0

nciParRead

Definition Network config input SNVT_count nciParRead

Explanation Chooses the parameter value to be read from the drive.

Valid Range 1 - 46

Default Value 0

LonWorks Network Variables

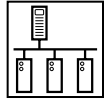

nciParWrite

| | |
|---------------|---|
| Definition | Network config input SNVT_count nciParWrite |
| Explanation | Chooses the parameter value to be written to the drive. |
| Valid Range | 1 - 46 |
| Default Value | 0 |

4.5 LonWorks XIF Files

The LonMark external interface (or XIF) file is used to set up a LonWorks network with an MCH Series drive that has not yet been commissioned. These files are available for download in the Technical Library of the Lenze-AC Tech website.

Use Drive Parameter #63 to retrieve the software version of your MCH drive. Drives with software versions MC11103 and later, and MC121xx use the 21312203.XIF file. If your MCH drive has an earlier software version (MC11101 or MC11102), then contact technical support for the appropriate XIF file.

4.6 Reference and Links

MCH Series Variable Frequency Drives visit:

<http://www.lenze-actech.com>

LonWorks and Echelon Corporation visit:

<http://www.echelon.com>

LonMark Functional Profiles (including 6010) visit:

<http://www.lonmark.org>

ANYBUS-S Drive Profile Embedded Interface Cards, LonMark 6010 Functional Profile visit:

<http://www.anybus.com/products/abs.shtml>

AC Technology Corporation

630 Douglas Street • Uxbridge MA 01569 • USA
Sales: 800-217-9100 • Service: 508-278-9100
www.lenze-actech.com

RG-MHLON-e3