

Getting Started

In This Chapter. . . .

- Introduction
 - HSC Features
 - How Does the HSC Work With the CPU?
 - Physical Characteristics & Specifications
 - Overview of HSC Inputs and Outputs
 - X Input and Y Output Assignments
 - Putting It All Together
-

Introduction

The Purpose of this Manual

Thank you for purchasing the High Speed Counter module for the DL405. This manual shows you how to install, program, and maintain the equipment. It also helps you understand the module's operating characteristics. Since we constantly try to improve our product line, we occasionally issue addenda that document new features and changes to the products. If an addendum is included with this manual, please read it to see which areas of the manual or product have changed.

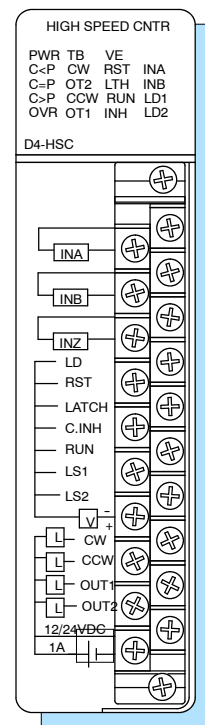

Who Should Read this Manual

If you understand PLC systems, this manual will provide all the information you need to get and keep your High Speed Counter module up and running. We will use examples and explanations to clarify our meaning and perhaps help you brush up on specific features used in the DL405 system. This manual is not intended to be a generic PLC training manual, but rather a user reference manual for the DL405 High Speed Counter Module.

Where to Begin

If you are in a hurry and already understand the basics of high speed counters and basic motion control, you may only want to skim this chapter, and move on to Chapter 2, Installation and Wiring.

Be sure to keep this manual handy for reference when you run into questions. If you are a new DL405 customer, we suggest you read this manual completely so you can fully understand the high speed counter module's configurations and the procedures used. We believe you will be pleasantly surprised with how much you can accomplish with PLC**Direct**[™] products.

Supplemental Manuals

Depending on the products you have purchased, there may be other manuals necessary for your application. You will want to supplement this manual with any other manuals written for other products. We suggest:

- D4-USER-M (the D4-405 User Manual)
- DA-DSOFT-M (the **DirectSOFT** User Manual)

Technical Assistance

If you have questions that are not answered by this manual, our Technical Support Team is glad to help. They are available from 9:00AM until 6:00PM Eastern Time Monday through Friday at 800-633-0405.

Chapters

Below is a table showing a summary of contents provided within each section of this manual. The manual is organized into the following seven chapters:

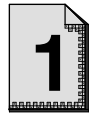
**Getting Started**

includes a brief description of the high speed counter module, common applications for high speed counters, and an overview of the steps necessary to setup and operate the high speed counter.

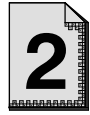
**Installation and Wiring**

shows you step-by-step how to install and wire the HSC. Includes wiring diagrams.

**Understanding Operation**

a must for understanding the rest of the manual. It covers the shared memory concept, the assignment of data types for the HSC, and how values are stored.

**Setting Up and Controlling the Count**

covers offsets and presets, which are needed for many applications. It provides the programming tools needed to make full use of the counting capability. It includes count inhibiting, count latching and overflow flags.

**Controlling the Outputs**

this chapter introduces you to the HSC's four different control outputs. It shows you how HSC RUN uses your preset information and current count to trigger the outputs in an ordered format. It also covers "manual" operation of the outputs *without* using HSC RUN.

**Special Features**

covers two special features that have been built into the HSC. You will learn about sampling and home search capabilities.

**Applications**

shows you how to write programs that will provide possible solutions for some common applications you might encounter.

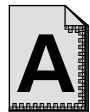
Appendices**Introduction to Motor Drives and Shaft Encoders**

although **PLCDirect™** does not provide encoders or motor drives, we have included a brief overview explaining some of the more common encoders and electronic drives that may be used with the D4-HSC High Speed Counter.

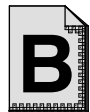
**Introduction to Motor Drives and Shaft Encoders**

this includes the X and Y data type assignment chart and an address map for the seven shared memory parameters.

Other Resources

You can also check our online resources for the latest product support information:

- **Internet** - the address of our Web site is <http://www.plcdirect.com>
- **Bulletin Board Service (BBS)** - call (770) 844-4209



The "note pad" icon in the left-hand margin indicates the paragraph to its immediate right will be a **special note**.

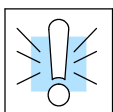

The "exclamation mark" icon in the left-hand margin indicates the paragraph to its immediate right will be a **warning** or **caution**. These are very important because the information may help you prevent serious personal injury or equipment damage.

HSC Features

What is a High Speed Counter?

Literally, high speed counters count fast! The D4-HSC high speed counter has one channel for counting pulses from sensors, encoders, switches, and so on, at rates up to 100 kHz (50% duty cycle). It is designed to make your job simpler. The HSC has its own microprocessor that asynchronously counts and accumulates the high speed pulses. This means the main CPU of the DL405 is free to do the other important tasks. It can simply check the accumulated count when it needs to do so.

Who Needs a High Speed Counter?

If you have an application that needs to count pulses rapidly, then you are a prime candidate for an HSC. The D4-HSC also has 4 outputs that can be used for controlling motor speed and direction. There is one special requirement. The variable speed motors or motor drives that are used must be capable of changing speed when receiving a voltage input between 10.2 VDC and 26.4 VDC. Many digital drives being offered today offer programmable input capability, precisely for this sort of application.

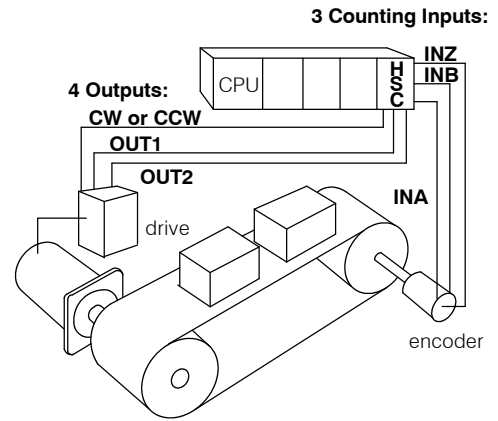

NOTE: The motor control capability should not be confused with a pulse output capability such as used with stepper motors. The D4-HSC outputs a voltage level dependent on an external power supply and **does not have pulse output capability**. You should check the specs of your drive or motor carefully to make certain that the specifications of this module match your application requirements.

Types of Counting

The D4-HSC can do **standard** UP and DOWN counting or it can do **quadrature** counting. These are software selectable as two different modes.

Standard Counting

With standard counting you can use the two counting input signals (**INA** and **INB**) of the D4-HSC. One input is used for counting UP and the other used for counting DOWN. You can't use both inputs for the same direction of counting.

You could be using only one of the inputs if desired. In this case, the other input terminal should be left unwired. You control the direction of counting by the manner in which you set a certain bit in your control program (shown later).

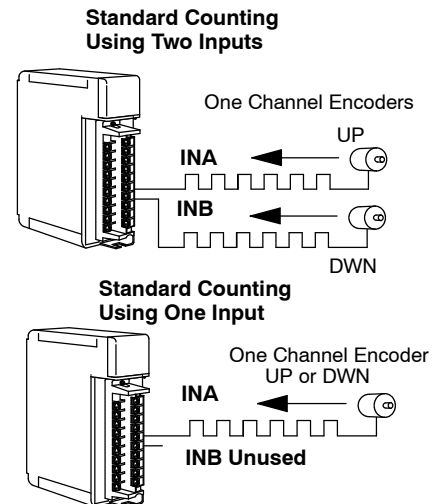

Quadrature Counting

With quadrature counting, you must use both signals (**INA** and **INB**). Both input terminals are connected to the same field device, capable of outputting two square wave signals, each being offset 90 degrees. Quadrature counting is often preferred to standard counting because it can sense direction. Quadrature inputs are also more noise immune. With quadrature counting, the direction (UP or DOWN counting) is determined by whether the signal being received at INA leads or lags the signal received at INB. The D4-HSC looks at the signals coming in and compares them. It then determines which is leading and which is lagging. **NOTE:** We have not shown the optional use of the Z-output signal (connected to INZ of the HSC) that comes standard on most quadrature encoders. The use of this input option will be discussed when we cover resetting the counter externally and the automatic home search feature.

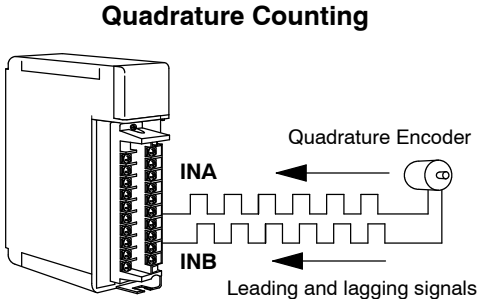

With a rotary encoder, the leading and lagging signal is determined by which direction the shaft is turning. This is how quadrature counting is able to sense direction.

Output Control

A typical application for the D4-HSC might be that of having a quadrature type shaft encoder connected to your motor with the HSC counting and accumulating the pulses from the encoder as the motor rotates. The HSC knows which way the motor shaft is turning because it knows which of the two signals being received is leading and lagging. You can write ladder logic to change either the motor's speed or direction. (We'll show you how to do that a little later!) The D4-HSC provides output signals that can be used to change speed or direction. Usually these signals are connected to an electronic drive or motor controller rather than the motor itself. Some motors are "smart" with built-in logic circuitry for initiating speed and direction changes. In these exceptional cases, the HSC can be connected directly to the motor to initiate the changes. We leave it up to you to specify the motor control and thus dictate the load side of the application. **Make sure you check the specs of your motor or motor controller and that you are sure they match up with the specs of D4-HSC before making any connections.**

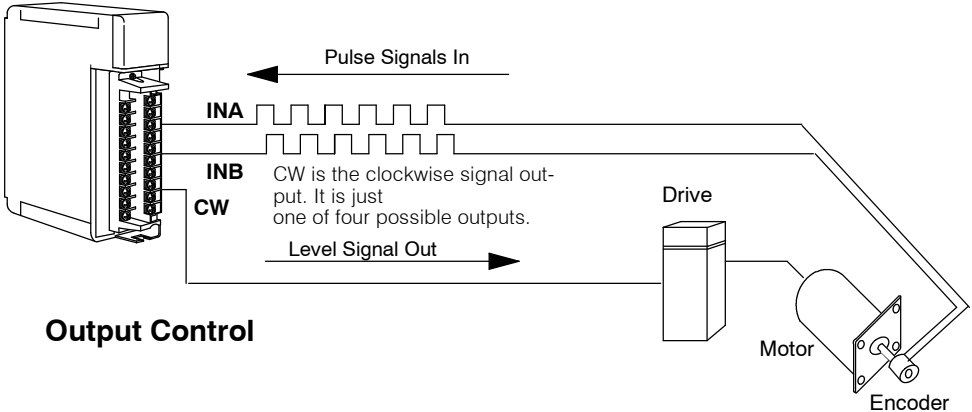

Sampling

The HSC can also do sampling over time. That is, you can use simple ladder logic instructions to indicate the time period for a sampling. When you invoke the sampling feature of the HSC, it will keep track of the counted pulses for the time period you have specified and store the total for later RLL retrieval. This is a great feature for determining frequency of incoming pulses. It's as simple as specifying a time base, say 3 seconds, and then counting the pulses for that period. If the HSC sees 6000 pulses during that time span, then you know that you have an incoming pulse rate of 2 kHz ($6000/3=2000$). There are many other uses for the sampling feature--frequency counting is just one example.

Home Search

Many applications require a known starting position for a given work cycle, called "home point". This is the point to which the moving piece of apparatus doing the work (i.e. welder, drill, saw, glue gun, etc.) is returned at the end of each work cycle.

The HSC has an automatic feature that is designed to help find and return to a home position at the end of each work cycle. You could, of course, write your own home search RLL. However, the D4-HSC relieves you of that task. Since the algorithm associated with the automatic home search routine assumes a certain type of configuration, you will have to make sure that the components and position of each meets certain specified criteria. Then, you activate the home search using a Y-output relay. The HSC takes over from there. We'll show you how to do this later in this manual.

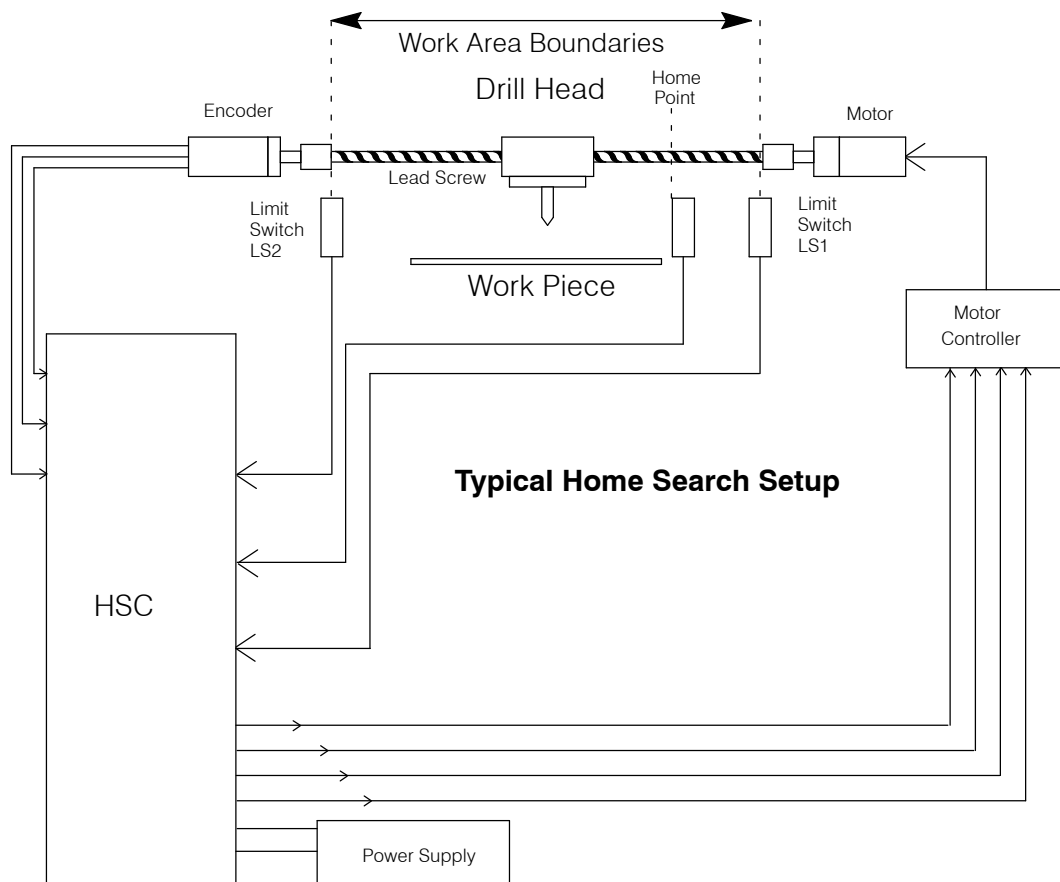

How Does the HSC Work With the CPU?

Setup Performed Via Shared Memory The D4-HSC is an intelligent module that has its own microprocessor and memory. The microprocessor operates asynchronously to the DL405 CPU. Its memory area is called “shared memory”, because both the DL405 CPU and the HSC can read and write to this area. In fact, that’s how you handle important items like-- telling the counter your preset value. In this case, you store parameters first in your DL405 CPU’s V-memory area; and then you transfer them to the shared memory area. Then, the HSC can read and use the information. The HSC microprocessor cannot read information directly from the DL405’s V-memory area. Likewise, it cannot write information directly into the CPU’s V-memory area. This is why the two-step process is always necessary.

The diagram below shows you the basic concept. Chapter 4 will cover the subject in depth.

The CPU and the HSC do not communicate directly. They do so by exchanging information to and from the shared memory area, via the CPU’s V-Memory. Your ladder logic decides what information and when it is read and written between the two memory areas.

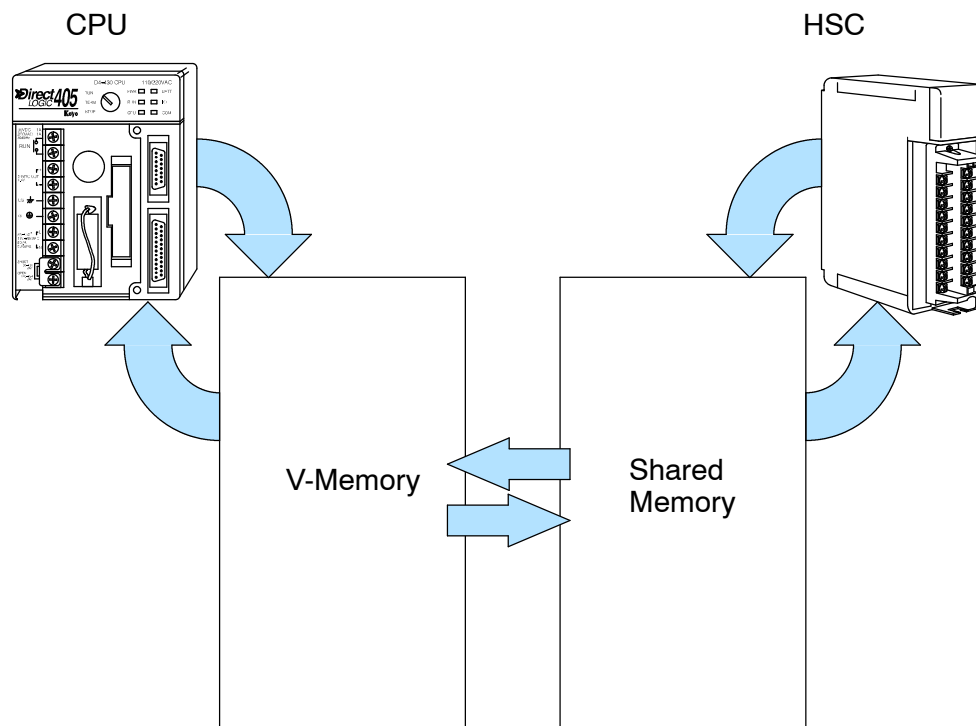

Physical Characteristics & Specifications

LED Assignments

Label	Function
PWR	5V POWER ON
C<P	CURRENT COUNT LESS THAN PRESET
C=P	CURRENT COUNT EQUAL TO PRESET
C>P	CURRENT COUNT MORE THAN PRESET
OVR	COUNT OVERFLOW
TB	LOOSE OR MISSING TERMINAL BLOCK
CW	CLOCKWISE OUTPUT ENERGIZED
OUT2	BRAKE (OUT2) OUTPUT ENERGIZED
CCW	COUNTER CLOCKWISE OUTPUT ENERGIZED
OUT1	DECELERATION (OUT1) OUTPUT ENERGIZED
VE	EXTERNAL POWER SUPPLY FOR OUTPUTS FAILED
RST	SIGNAL APPLIED TO RESET INPUT (External Only)
LTH	SIGNAL APPLIED TO LATCH INPUT (External Only)
RUN	SIGNAL APPLIED TO RUN INPUT (External Only)
INH	SIGNAL APPLIED TO INHIBIT CNT INPUT (External Only)
INA	SIGNAL APPLIED TO INA INPUT
INB	SIGNAL APPLIED TO INB INPUT
LD1	SIGNAL APPLIED TO INZ INPUT
LD2	SIGNAL APPLIED TO LD INPUT

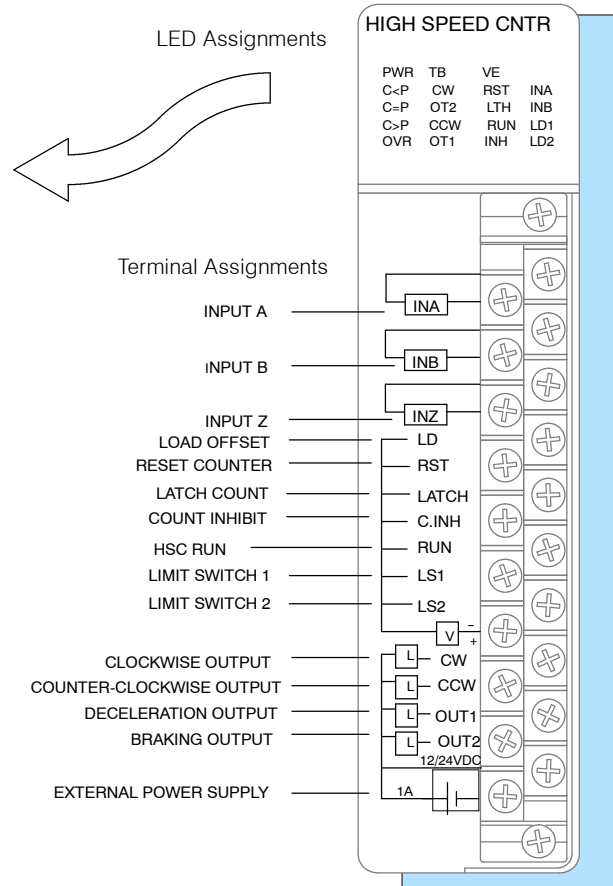

General Specification	Rating or Requirement
405 CPU Firmware Requirements	Any PLCDirect CPU or other vendor's 405 CPU (Version 1.6 or later.)
Slot for Installation	Can be installed in any CPU or expansion base. Cannot be installed in a remote base.
Maximum No. HSC's per CPU	8
No. of I/O points required	Consumes 16 X-inputs and 32 Y-outputs
Intelligence Source	Has its own microprocessor (operates asynchronously to the DL405 CPU)
Internal Power Consumption	300 mA maximum at 5VDC
Field Wiring Connector	Removable terminal type
Count Signal Level	4.75VDC to 30VDC less than 10mA
Maximum Count Speed	100 kHz (50% duty cycle)
Minimum Input Pulse Width for Counting	5 μs (either state)
Count Input Signal Types	Standard (UP/DOWN) or quadrature (phase differential)
Count Range	-8,388,608 to +8,388,607
Count Direction	UP or DOWN (software selectable or hardwired)
CPU Scan Time Increase per HSC in base	4.2 to 5.5 ms

Counting Inputs (INA, INB, INZ)	Rating or Requirement
Input Voltage Range	4.75VDC to 30VDC
Maximum Input Current	10 mA
ON Voltage	4.75VDC
ON Current	5mA
OFF Voltage	2.0VDC
OFF Current	1.6mA
OFF to ON Delay	1.2 μ s at 5VDC 0.8 μ s at 12VDC 0.5 μ s at 24VDC
ON to OFF Delay	1.0 μ s at 5VDC 1.2 μ s at 12VDC 2.5 μ s at 24VDC

Control Inputs (LD, LATCH, RST, CINH, RUN, LS1 LS2)	Rating or Requirement
Input Voltage Range	10.2VDC-26.4VDC
Maximum Input Current	10mA
ON Voltage	10.2VDC
ON Current	5mA (LD and LATCH); \geq 4.8mA (RST,CINH,RUN,LS1 and LS2)
OFF Voltage	4.6VDC (LD and LATCH); \leq 5.6VDC (RST,CINH,RUN,LS1 and LS2)
OFF Current	1.6mA (LD and LATCH); \leq 2mA (RST,CINH,RUN,LS1 and LS2)
OFF to ON Delay	75 μ s at 12VDC (LD and LATCH) 82.5 μ s at 12VDC (RST,CINH,RUN,LS1 and LS2) 30 μ s at 24VDC (LD and LATCH) 37.5 μ s at 24VDC (RST,CINH,RUN,LS1 and LS2)
ON to OFF Delay	240 μ s at 12VDC (LD and LATCH) 105 μ s at 12VDC (RST,CINH,RUN LS1 and LS2) 260 μ s at 24VDC (LD and LATCH) 105 μ s at 24VDC (RST,CINH,RUN LS1 and LS2)

Control Outputs (CW,CCW,OUT1,OUT2)	Rating or Requirement
Output Power Source	External 10.2VDC-26.4VDC, 1A
Output Type	Open Collector
Maximum Output Current	100 mA per point
Output ON Voltage Drop	1.5VDC
Output OFF Leakage Current	100 μ A
Output OFF to ON Delay	22.5 μ s at 12VDC 21 μ s at 24VDC
Output ON to OFF Delay	210 μ s at 12VDC 270 μ s at 24VDC
Built-In Protection	Shut off when output driver IC=175°C (Recovers at 150°C) Shut off when short (500mA) is detected (Recovers when short is removed)
Input-pulse-reaching-Preset to internal-signal-reaching-Output 1 Time Delay	110 μ s

Overview of HSC Inputs and Outputs

Counting Inputs

INA-Depending on mode chosen, this is either a standard UP/DOWN counter input, or one of the quadrature counter inputs.

INB-Depending on mode chosen, this is either a standard UP/DOWN counter input, or one of the quadrature counter inputs.

INZ-This input can be used to *help you find home position* for positioning control. It can also be used as an external means of resetting the counter.

Control Inputs

LD-If you want to *use an offset number with your counting*, a rising edge signal at this terminal will copy the offset value into the current count.

RST-A high (ON) signal at this terminal *resets the counter to zero and it remains there until there is a transition to a low signal (OFF)*.

LATCH - You may want to *store the current count*. The rising edge of a signal at this terminal will store the current count in shared RAM. Counting continues with no interruption.

C.INH- You may want to temporarily ignore the count inputs coming in on INA and INB. A high (ON) signal at this terminal will *inhibit the counting* to accomplish this need. Current count is suspended until a transition to a low (OFF) signal is seen.

RUN-Not to be confused with RUN mode of the DL405, a high (ON) signal here will *activate HSC RUN*. A low (OFF) signal will de-activate it.

LS1 or LS2-Either or both of these terminals can be connected to limit switches to help find home position, or they can merely be used as discrete inputs.

Control Outputs

CW-You connect the output of this terminal to the appropriate terminal of your motor controller for *clockwise motion* when current count is **less than preset** and HSC RUN is ON, or when the output has been turned ON with RLL.

CCW-You connect the output of this terminal to the appropriate terminal of your motor controller for *counter-clockwise motion* when current count is **more than preset** and HSC RUN is ON, or when the output has been turned ON with RLL.

OUT1 - As you approach a target position, you may need to *trigger motor deceleration*. A signal from this output can do that. This is used in the automatic home search algorithm also.

OUT2 - When you reach your target (current count=preset), you may need to *activate a brake to stop the motor*. A signal from this output can do that.

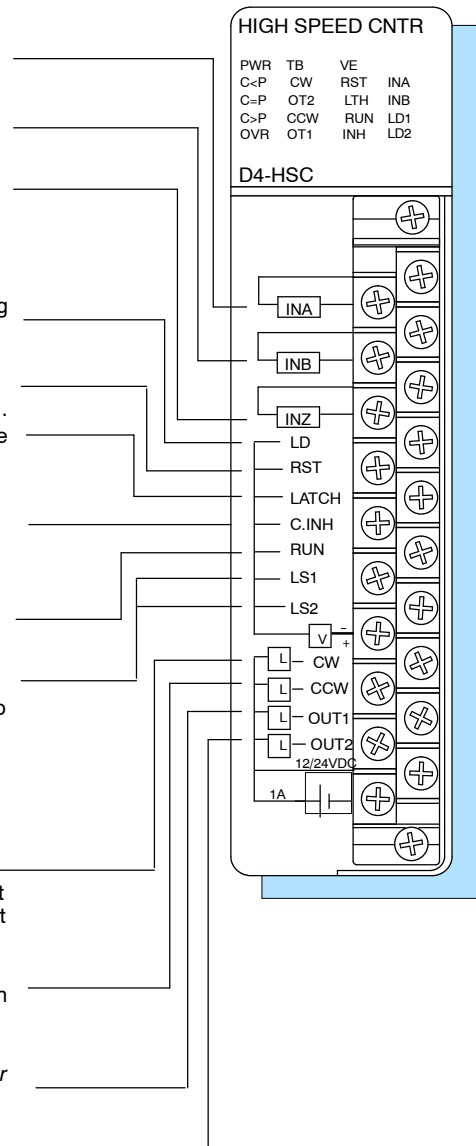

Y Data Type Equivalents for Some Functions

LD, RST, LATCH, C.INH, and RUN all have software equivalents built-in to the logic of the D4-HSC. These are Y data types that are discussed on the next page. Thus, you have your choice of either triggering these control inputs *externally* or accomplishing essentially the same task *internally from within your RLL*. They have been shaded to make them easy to spot.

NOTE: Use **external inputs** if immediate responses are needed. When a function is activated through RLL (Y-outputs in this case), the function will not activate until the I/O update has been performed. This delay is dependent on your CPU's scanning speed and the size of your program.

X Input and Y Output Assignments

There are certain X's and Y's reserved by the D4-HSC. By convention, we will be referring to these assignments as Xn+(z) and Ym+(z) where n and m are offset values based on which slot of the CPU base you have placed your HSC. The letter z will be some octal number that maps the X or Y to a specific input or output function. For example if you have the HSC in slot 0, and are using automatic addressing, then m and n will both be equal to zero. In such case, the data type assignments would be as shown below. All of this is explained in great detail in Chapter 4. You will also at that time be given a complete table of the X and Y assignments.

In this example we have placed the HSC in slot 0 of the CPU base. This simplifies X and Y identification because X's and Y's both start at 00.

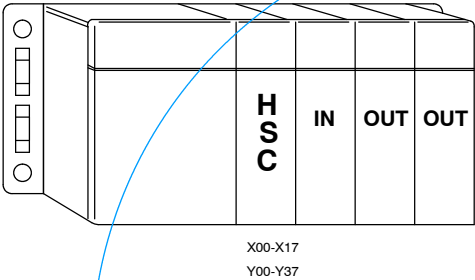

For example:
 $X_{n+6} = X_6 =$ Status of CW output
 $Y_{m+3} = Y_3 =$ ON for HSC RUN

X No.	Function
Xn+0	ON if current count is greater than preset
Xn+1	ON if current count is equal to preset
Xn+2	ON if current count is less than preset
Xn+3	Latched ON if overflow occurs (reset with Ym+1)
Xn+4	Status of CCW output
Xn+5	Status of OUT2 (brake) output
Xn+6	Status of CW output
Xn+7	Status of OUT1 (deceleration) output
Xn+10	Status of Limit Switch 2
Xn+11	Status of Limit Switch 1
Xn+12	ON if doing a search for home position
Xn+13	ON if a sampling is being conducted
Xn+14	NOT USED
Xn+15	ON for missing terminal block
Xn+16	ON if external power supply for outputs is missing or OFF

Y No.	Function
Ym+0	ON to reset OUT1 and OUT2 when in HSC run
Ym+1	ON to reset overflow flag (Xn+3)
Ym+2	Rising edge of this signal copies offset value into current count
Ym+3	ON for HSC run
Ym+4	Used to control CCW when not in HSC RUN or Home Search
Ym+5	Used to control OUT2 when not in HSC RUN or Home Search
Ym+6	Used to control CW when not in HSC RUN or Home Search
Ym+7	Used to control OUT1 when not in HSC RUN or Home Search

Putting It All Together

Up to this point, we have given you only the very basic information about the HSC module. The six chapters that follow will give you the additional information you need to make full use of the HSC. There are five basic steps for using the HSC.

Five Steps for Using the HSC

Document **Install the Module and Connect the Wiring** — Chapter Two

Document **Understand How the Module Maps into the I/O Points, and How the Setup Information is Stored** — Chapter Three

Document **Setup the Counting and Control Input Parameters** — Chapter Four

Document **Setup the Control Outputs** — Chapter Five

Document **Setup Any Special Features, Such as Home Search or Sampling** — Chapter Six

The Next Chapter

The next chapter will walk you through the installation and wiring before moving you on to Step 2.
