



## Artisan Technology Group is your source for quality new and certified-used/pre-owned equipment

- FAST SHIPPING AND DELIVERY
- TENS OF THOUSANDS OF IN-STOCK ITEMS
- EQUIPMENT DEMOS
- HUNDREDS OF MANUFACTURERS SUPPORTED
- LEASING/MONTHLY RENTALS
- ITAR CERTIFIED SECURE ASSET SOLUTIONS

### SERVICE CENTER REPAIRS

Experienced engineers and technicians on staff at our full-service, in-house repair center

### *InstraView*<sup>SM</sup> REMOTE INSPECTION

Remotely inspect equipment before purchasing with our interactive website at [www.instraview.com](http://www.instraview.com) ↗

### WE BUY USED EQUIPMENT

Sell your excess, underutilized, and idle used equipment. We also offer credit for buy-backs and trade-ins. [www.artisanng.com/WeBuyEquipment](http://www.artisanng.com/WeBuyEquipment) ↗

### LOOKING FOR MORE INFORMATION?

Visit us on the web at [www.artisanng.com](http://www.artisanng.com) ↗ for more information on price quotations, drivers, technical specifications, manuals, and documentation

**Contact us:** (888) 88-SOURCE | [sales@artisanng.com](mailto:sales@artisanng.com) | [www.artisanng.com](http://www.artisanng.com)

# User Manual



**73A-308**

**Relay and High Voltage Logic Driver Module**

**070-9118-02**



This document applies for firmware version 1.00  
and above.

Copyright © Tektronix, Inc. All rights reserved.

Tektronix products are covered by U.S. and foreign patents, issued and pending. Information in this publication supercedes that in all previously published material. Specifications and price change privileges reserved.

Printed in the U.S.A.

Tektronix, Inc., P.O. Box 1000, Wilsonville, OR 97070-1000

TEKTRONIX and TEK are registered trademarks of Tektronix, Inc.

## WARRANTY

Tektronix warrants that this product will be free from defects in materials and workmanship for a period of three (3) years from the date of shipment. If any such product proves defective during this warranty period, Tektronix, at its option, either will repair the defective product without charge for parts and labor, or will provide a replacement in exchange for the defective product.

In order to obtain service under this warranty, Customer must notify Tektronix of the defect before the expiration of the warranty period and make suitable arrangements for the performance of service. Customer shall be responsible for packaging and shipping the defective product to the service center designated by Tektronix, with shipping charges prepaid. Tektronix shall pay for the return of the product to Customer if the shipment is to a location within the country in which the Tektronix service center is located. Customer shall be responsible for paying all shipping charges, duties, taxes, and any other charges for products returned to any other locations.

This warranty shall not apply to any defect, failure or damage caused by improper use or improper or inadequate maintenance and care. Tektronix shall not be obligated to furnish service under this warranty a) to repair damage resulting from attempts by personnel other than Tektronix representatives to install, repair or service the product; b) to repair damage resulting from improper use or connection to incompatible equipment; or c) to service a product that has been modified or integrated with other products when the effect of such modification or integration increases the time or difficulty of servicing the product.

**THIS WARRANTY IS GIVEN BY TEKTRONIX WITH RESPECT TO THIS PRODUCT IN LIEU OF ANY OTHER WARRANTIES, EXPRESSED OR IMPLIED. TEKTRONIX AND ITS VENDORS DISCLAIM ANY IMPLIED WARRANTIES OF MERCHANTABILITY OR FITNESS FOR A PARTICULAR PURPOSE. TEKTRONIX' RESPONSIBILITY TO REPAIR OR REPLACE DEFECTIVE PRODUCTS IS THE SOLE AND EXCLUSIVE REMEDY PROVIDED TO THE CUSTOMER FOR BREACH OF THIS WARRANTY. TEKTRONIX AND ITS VENDORS WILL NOT BE LIABLE FOR ANY INDIRECT, SPECIAL, INCIDENTAL, OR CONSEQUENTIAL DAMAGES IRRESPECTIVE OF WHETHER TEKTRONIX OR THE VENDOR HAS ADVANCE NOTICE OF THE POSSIBILITY OF SUCH DAMAGES.**

## EC Declaration of Conformity

We

Tektronix Holland N.V.  
Marktweg 73A  
8444 AB Heerenveen  
The Netherlands

declare under sole responsibility that the

**73A-308**

meets the intent of Directive 89/336/EEC for Electromagnetic Compatibility.  
Compliance was demonstrated to the following specifications as listed in the Official  
Journal of the European Communities:

EN 55011                    Class A Radiated and Conducted Emissions

EN 50081-1 Emissions:

EN 60555-2    AC Power Line Harmonic Emissions

EN 50082-1 Immunity:

IEC 801-2        Electrostatic Discharge Immunity

IEC 801-3        RF Electromagnetic Field Immunity

IEC 801-4        Electrical Fast Transient/Burst Immunity

IEC 801-5        Power Line Surge Immunity

To ensure compliance with EMC requirements only high quality shielded cables having a reliable, continuous outer shield (braid & foil) which has low impedance connections to shielded connector housings at both ends should be connected to this product.

# 73A-308 RELAY AND HIGH VOLTAGE LOGIC DRIVER MODULE QUICK REFERENCE GUIDE

Numbers in parentheses refer to the page(s) in the Operating Manual.

## SETUP

- Be sure all switches are correctly set. (p. 3)
- Follow Installation guidelines. (p. 10)

The default condition of the 73A-308 Module after the completion of power-up self test is as follows:

- All relay driver outputs disabled.
- VXlibus external triggers disabled.
- Non-buffered mode.
- Request True interrupts disabled.
- Wait hold off disabled.

## LEDs

When lit, the LEDs indicate the following:

- Power Failed
- ERR an error has been found in self test or programming module failure
- MSG module is processing a VMEbus cycle
- ENB indicates the output drivers are enabled
- R9 - R0 this bit of the currently displayed byte is pulled low. R9 = MSB, R0 = LSB.
- MSD 10s digit for the relay LEDs (R9-R0):

MSD Selected	D4	LED status:	D2	D1
0	unlit	unlit	unlit	unlit
1	unlit	unlit	unlit	lit
2	unlit	lit	lit	unlit
3	unlit	lit	lit	lit
4	lit	unlit	unlit	unlit
5	lit	unlit	unlit	lit
6	lit	lit	lit	unlit
7	lit	lit	lit	lit

spaces whose length is greater than or equal to the maximum number of bytes expected from the 73A-332.

CALL SEND (ADDRESS%, WRT\$, STATUS%)

Outputs the contents of the string variable WRT\$ to the IEEE-488 instrument whose decimal primary address is in the variable ADDRESS%. The variable STATUS% = '0' if the transfer was successful and an '8' if an operating timeout occurred in the PC.

END Terminates the program.

FOR/NEXT Repeats the instructions between the FOR and NEXT statements for a defined number of iterations.

GOSUB n Runs the subroutine beginning with line n. The end of the subroutine is delineated with a RETURN statement. When the subroutine reaches the RETURN statement, execution will resume on the line following the GOSUB command.

GOTO n Program branches to line n.

IF/THEN Sets up a conditional IF/THEN statement. Used with other commands, so that IF the stated condition is met, THEN the command following is effective.

REM All characters following the REM command are not executed.

RETURN Ends a subroutine and returns operation to the line after the last executed GOSUB command.

<CR> Carriage Return character, decimal 13.

<LF> Line Feed character, decimal 10.

## ERRORS

If an error is queued, the module will respond with 'ERROR' until a QE command is issued. See the Q command description, p. 27, for a full description.

- 0 NO ERRORS
- 1 SELF TEST FAILURE (BANK X BIT - B DATA Y-Z)
- 2 SYNTAX ERROR
- 3 INPUT BUFFER OVERFLOW
- 4 TOO MANY DIGITS IN EXPONENT
- 5 TWO DECIMAL POINTS WITHIN NUMBER
- 6 INVALID CHANNEL NUMBER 'X'
- 7 INVALID TRIGGER VALUE 'X'
- 8 INVALID QUERY COMMAND 'X'
- 9 INVALID LOAD COMMAND - WRONG NUMBER OF CHARACTERS 'X'
- 10 INVALID (OR MISSING) HEX VALUE 'X'
- 11 INVALID INTERRUPT COMMAND 'X'
- 12 MAXIMUM SEQUENCE LENGTH EXCEEDED - XX
- 13 INVALID BANK NUMBER 'X'
- 14 INVALID WAIT VALUE 'X'
- 15 UNKNOWN ERROR

---

### SYSTEM COMMANDS

These non-data commands are initiated by the 73A-308's commander. The following VXibus Instrument Protocol commands affect the 73A-308:

ABORT NORMAL OPERATION	END NORMAL OPERATION
ASYNCHRONOUS MODE CONTROL	ERROR QUERY
BEGIN NORMAL OPERATION	IDENTIFY COMMANDER
BYTE AVAILABLE	READ PROTOCOL
CLEAR	READ STATUS
CONTROL EVENT	TRIGGER

---

### COMMAND SYNTAX

Command protocol and syntax for the 73A-308 Module is as follows: (15)

- 1) Commands consist of a string of up to 255 characters and must end with either a <LF> or a (.) delimiter. A <CR> is treated as a white space character, and is ignored if received.
  - 2) All commands are operated on in the order they are received, and executed when the delimiter is received.
  - 3) If a parameter is omitted, either its default state or its last programmed state will be in effect (depending on the command).
  - 4) Any character may be sent in either upper or lower case form.
  - 5) Any of the following white space characters are allowed within the command string, and are ignored by the module:  
00-09, 0B-20, 80-89, 8B-90
  - 6) Any command syntax or programming errors will cause an error to be flagged. All commands up to the error will remain valid. The invalid command will be ignored, and all following valid commands will be accepted. Clear the error condition by hardware or software reset. Q command, or unprogrammed readback.
  - 7) All responses from the module are terminated by a <CR> <LF>.
  - 8) A command may be issued in either the full or the short form.
- 

### MODULE COMMANDS

Commands may be issued either in full or short form. Only the short form is listed here.

- BD puts the module in non-buffered mode (default). (17)
- BE puts the module in buffered mode. (18)
- 

C z close an external relay connection to an individual control line. (19)

CB z allows the system controller to close a bank of outputs (8 drivers). (20)

D disables all relay drivers. (21)

E enables all relay drivers. (22)

Iz enables or disables the VXI Request True interrupt; can be programmed to be active when an error occurs, when a trigger is received, on either event, or to disable all interrupts. (23)

L{R<sub>20</sub>... R<sub>0</sub>} loads hex data bytes to output drivers. (24)

O z opens an external relay connection to an individual control line. (25)

OB z allows the system controller to open a relay bank (8 relay drivers). (26)

Oz read the current state of the module: (27)  
- error data  
- the trigger setup programmed  
- trigger status, whether trigger has occurred  
- driver status (enabled or disabled)

R resets the board to its power-up state. (30)

S the module executes a self test, then returns to its previously programmed state. (31)

T pulse a VXibus TTL trigger line specified by the Trigger Setup command. (32)

TS x,y sets up VXibus TTL trigger lines in and out. (33)

V returns the current software revision level of the board. (35)

W x waits for a specified number of 1 ms intervals before accepting commands. (36)

---

PROGRAMMING The programming examples in the manual are written in Microsoft GW BASIC. For programming examples, see page 38.

CALL ENTER (R\$, LENGTH%, ADDRESS%, STATUS%)

Inputs data into the string R\$ from the IEEE-488 instrument whose decimal primary address is contained in the variable ADDRESS%. LENGTH% = the number of bytes read from the instrument. STATUS% = '0' if the transfer was successful; 'g' if an operating system timeout occurred in the PC. To use the CALL ENTER statement, the string R\$ must be set to a string of

# Table of Contents

## Description

Introduction .....	1
Controls And Indicators .....	3
Switches .....	3
Fuses .....	4
LEDs .....	4
BITE (Built-In Test Equipment) .....	5

<b>Specifications</b> .....	<b>6</b>
-----------------------------	----------

## Installation

Installation Requirements and Cautions .....	10
Installation Procedure .....	11
Installation Checklist .....	12

## Operation

Overview .....	14
Power-up .....	14
System Commands .....	14
Module Commands .....	14
Command Summary .....	15
Command Descriptions .....	17
SYSFAIL, Self Test, and Initialization .....	37
Programming Examples .....	37
Definition of BASIC Commands .....	37
Programming Examples in BASIC .....	38
Synchronizing Multiple Instrumentation Modules .....	43

## Appendices

Appendix A – VXIbus Operation .....	44
Appendix B – Front Panel Output Connections .....	50
Appendix C – VXIbus Glossary .....	54
Appendix D – Typical Driver Circuit .....	56
Appendix E – User Service .....	57
Appendix F – Performance Verification Procedure .....	69





# Safety Summary

The general safety information in this summary is for both operating and servicing personnel. Additional specific warnings and cautions are found throughout the manual where they apply, and may not appear in this summary.

## TERMS

### In This Manual

**WARNING** statements identify conditions or practices that could result in personal injury or loss of life.

**CAUTION** statements identify conditions or practices that could result in damage to the module or other property.

### Marked on the Module

**DANGER** indicates a personal injury hazard immediately accessible as one reads the marking.

**CAUTION** indicates a personal injury hazard not immediately accessible as one reads the marking, or a hazard to property, including the module itself.

## SYMBOLS

### In This Manual



This symbol indicates where applicable cautionary or other information is to be found.



This symbol indicates where special explanatory information is included in the manual. There is no caution or danger associated with the information.

### Marked on the Module



**DANGER** — High Voltage.



Protective ground (earth) terminal.



**ATTENTION** — Refer to the manual.



Refer to manual before using.

## Power Source

This module is intended to operate in a mainframe whose power source does not apply more than 250V rms between the supply conductors or between either supply conductor and ground. A protective ground connection through the grounding conductor in the power cord(s) is essential for safe operation.

## Grounding the Module

This module is grounded through the grounding conductor of the mainframe power cord(s). To avoid electrical shock, plug the mainframe power cord(s) into a properly wired receptacle before connecting to the module connectors. A protective ground connection through the mainframe is essential for safe operation.

## Danger Arising from Loss of Ground

Upon loss of the protective-ground connection, all accessible conductive parts can render an electric shock.

## Use the Proper Fuse

To avoid fire hazard, use only fuses specified in the module parts list. A replacement fuse must meet the type, voltage rating, and current rating specifications required for the fuse that it replaces.

## Do Not Operate in Explosive Atmosphere

To avoid explosion, do not operate the module in an explosive atmosphere.

## Do Not Remove Covers or Panels

To avoid personal injury, the module covers should be removed only by qualified service personnel. Do not operate the module without covers and panels properly installed.



# 73A-308 RELAY AND HIGH VOLTAGE LOGIC DRIVER MODULE

## DESCRIPTION

---

### INTRODUCTION

The 73A-308 Relay and High Voltage Logic Driver Module is a printed circuit board assembly for use in a card cage conforming to the VXIbus Specification, such as the 73A-021 used in the CDS 73A IAC System. The 73A-308 provides 80 open collector 300 milliamp relay drivers. The 80 programmable lines are organized as ten banks of eight relay drivers.

Each of the ten banks can be independently configured under full program control. All commands and responses are in ASCII hex notation for ease of programming, and to insure compatibility with the widest range of system controllers. Program controlled parameters include:

- o readback of current relay outputs, with or without drivers enabled,
- o control on command basis, VXIbus TTL trigger lines, or IEEE-488 Group Execute Trigger, and
- o full reporting of operating parameters at any time.

The outputs can be controlled as individual relay drivers and as banks of relay drivers. Output is controlled by commands, a VXIbus TTL trigger line, or an IEEE-488 Group Execute Trigger.

Relay driver lines can be set inactive (tri-state) or active low under program control.

All lines are capable of up to 300 mA of sink current per output, with a maximum voltage drop of 500 mV across the output to common. The 80 drivers have built-in transient suppression diodes or clamp diodes to eliminate voltage spikes created when relays turn off.

There are two output connectors on the 73A-308, P4 and P5. Each connector has the outputs of 40 drivers, two clamp diode lines, and eight grounds. The clamp diode lines may be jumpered to any of the five blocks of eight outputs (a single UDN-2596A driver chip is a block of eight drivers). Refer to Appendix D for a typical driver circuit.

The clamp lines are set at the factory, but may be changed if necessary. (See the Installation section for details.)

The 73A-308 provides full access to system status information, which is especially helpful during system trouble-shooting, software de-bugging, and operational system checks. At any time, the system controller can read the state of the relay driver outputs and up-to-date error data.

Note that certain terms used in this manual have very specific meanings in the context of a VXIbus System. These terms are defined in the VXIbus Glossary (Appendix C).

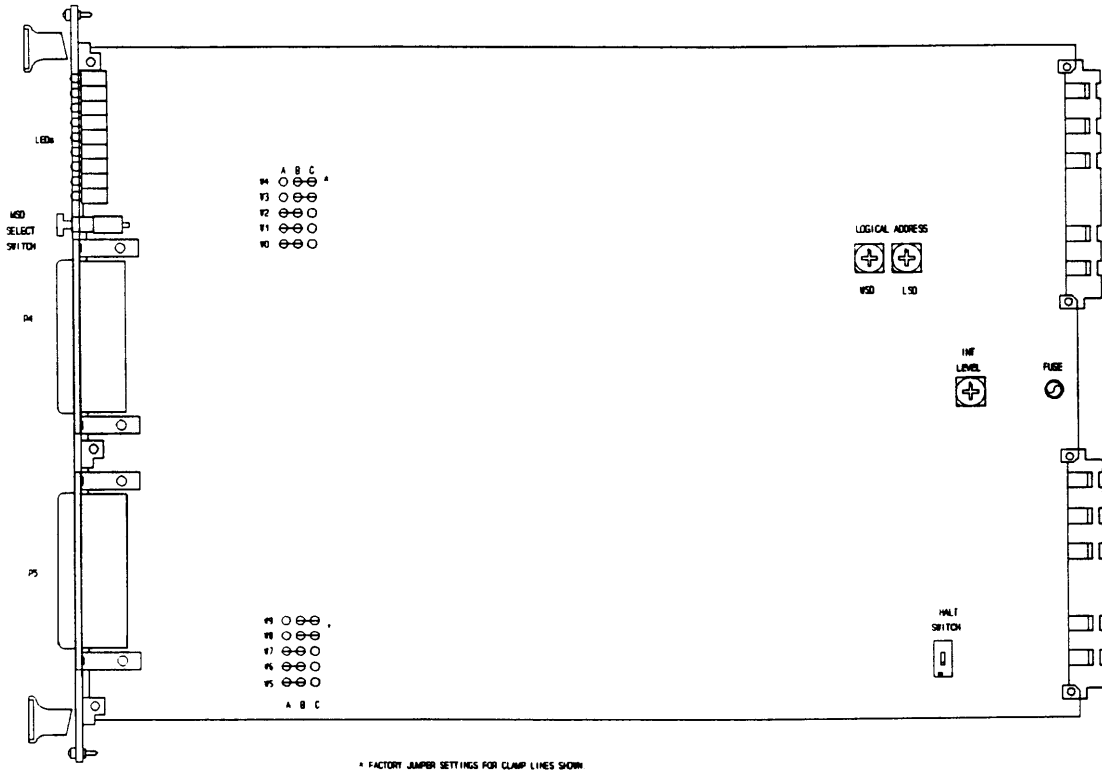

Figure 308-1A: 73A-308 Controls and Indicators

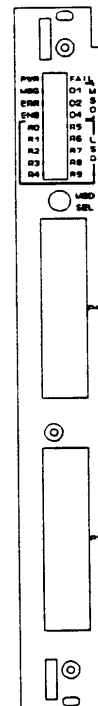

Figure 308-1B: Front Panel

## CONTROLS AND INDICATORS

The following controls and indicators are provided to select and display the functions of the 73A-308 Module's operating environment. See Figure 308-1 for their physical locations.

- **Switches**

### Logical Address Switches

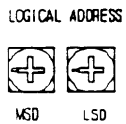

Each function module in a VXibus System must be assigned a unique logical address, from 1 to 255 decimal. The base VMEbus address of the 73A-308 is set to a value between 1 and FFh (255d) by two hexadecimal rotary switches. Align the desired switch position with the arrow on the module shield.

The actual physical address of the 73A-308 module is on a 64 byte boundary. If the switch representing the most significant digit (MSD) of the logical address is set to position X and the switch representing the least significant digit (LSD) of the logical address is set to position Y, then the base physical address of the 73A-308 will be  $[(64d * XYh) + 49152d]$ . For example:

M	L	Base Physical
L. S S	A. D D	Addr. (d)
Ah 0 A	(64*10)	+ 49152 = 49792d
15h 1 5	(64*21)	+ 49152 = 50496d

where: L.A. = Logical Address  
MSD = Most Significant Digit  
LSD = Least Significant Digit

### IEEE-488 Address

Using the 73A-308 Module in an IEEE-488 environment requires knowing the module's IEEE-488 address in order to program it.

The logical address switch on the 73A-155 Module is used to define the IEEE-488 address of the 73A-308 Module. Different manufacturers of IEEE-488 interface devices may have different algorithms for equating a logical address with an IEEE-488 address.

If the 73A-308 is being used in a CDS IEEE-488 IAC system, consult the operating manual of the CDS 73A-1XX Series slot 0 embedded controller or IEEE-488 Interface Module.

If the 73A-308 is being used in a MATE system, VXibus logical addresses are converted to IEEE-488 addresses using the algorithm specified in the MATE IAC standard (MATE-STD-IAC). This algorithm is described in detail in the 73A-156 Operating Manual.

If the 73A-308 is not being used in a CDS IAC System, consult the operating manual of the IEEE-488 interface device being used for recommendations on setting the logical address.

### VMEbus Interrupt Level Select Switch

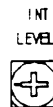

Each function module in a VXibus System can generate an interrupt on the VMEbus to request service from the interrupt handler located on its commander (for example, the 73A-155 RM/IEEE-488 Interface Module in a CDS 73A-IBX System). The VMEbus interrupt level on which the 73A-308 Module generates interrupts is set by a BCD rotary switch. Align the desired switch position with the arrow on the module shield.

Valid Interrupt Level Select switch settings are 1 through 7, with setting 1 equivalent to level 1, etc. The level chosen should be the same as the level set on the 73A-308's interrupt handler, typically the module's commander. Setting the switch to an invalid interrupt level (0, 8, or 9) will

disable the module's interrupts. When using the 73A-308 in a CDS 73A-IBX System, set the interrupt level to the same level chosen on the 73A-155.

Interrupts are used by the module to return VXibus Protocol Events to the module's commander. Refer to the Operation section for information on interrupts. The VXibus Protocol Events supported by the module are listed in the Specifications section.

### Halt Switch



This two-position slide switch selects the response of the 73A-308 Module when the Reset bit in the module's VXibus

Control register is set.

If the Halt switch is in the ON position, then the 73A-308 Module is reset to its power-up state and all programmed module parameters are reset to their default values.

If the Halt switch is in the OFF position, the module will ignore the Reset bit and no action will take place.

**NOTE:** The module is not in strict compliance with the VXibus Specification when the Halt switch is OFF.

Control of the Reset bit depends on the capabilities of the 73A-308's commander. In a CDS 73A-IBX System, for example, the Reset bit is set when the 73A-155 RM/IEEE-488 Interface Module receives a STOP command.

### MSD Select Switch

MSD  
SELECT  
SWITCH

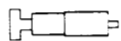

The MSD (Most Significant Digit) Select switch located on the front panel is a momentary action push button switch that selects

the tens digit for the relay drivers being displayed. Each time the switch is depressed, the state of the next ten relay

drivers is displayed. For example, if the state of MSD is 0 (all LEDs off), the state of relay drivers 0 through 9 will be displayed. If the MSD switch is pressed once, LED D1 will be lit. This will display relay driver lines 10 through 19.

### • Fuses

The 73A-308 Module has a single +5V fuse. The fuse protects the module in case of an accidental shorting of the power bus or any other situation where excessive current might be drawn.

If the +5V fuse opens, the VXibus Resource Manager will be unable to assert SYSFAIL INHIBIT on this module to disable SYSFAIL\*.

If the +5 V fuse opens, remove the fault before replacing the fuse. Replacement fuse information is given in the Specifications section of this manual.

### • LEDs

The following LEDs are visible at the top of the 73A-308 Module's front panel to indicate the status of the module's operation:

#### Power LED

This green LED is normally lit and is extinguished if the +5V power supply fails, or if the +5V fuse blows.

#### Failed LED

This normally off red LED is lit whenever a module failure is detected. Module failures include failure to correctly complete a self test, loss of the +5 power rail, or failure of the module's central processor.

**NOTE:** If the module loses its +5 power voltage, the Failed LED will be

lit and SYSFAIL\* asserted. A module power failure is indicated when the module's Power LED is extinguished.

**MSG LED**

This green LED is normally off. When lit, it indicates that the module is processing a VMEbus cycle. The LED is controlled by circuitry that appears to stretch the length of the VMEbus cycle. For example, a five microsecond cycle will light the LED for approximately 0.2 seconds. The LED will remain lit if the module is being constantly addressed.

**MSD**

These three LEDs labeled D1, D2, and D4 indicate the tens digit for the Relay Driver LEDs (R9-R0) that are currently being displayed, as shown:

MSD <u>Selected</u>	<u>LED status:</u>		
	<u>D4</u>	<u>D2</u>	<u>D1</u>
0	unlit	unlit	unlit
1	unlit	unlit	lit
2	unlit	lit	unlit
3	unlit	lit	lit
4	lit	unlit	unlit
5	lit	unlit	lit
6	lit	lit	unlit
7	lit	lit	lit

**ERR**

When lit, this indicates a programming error has occurred. This LED will remain lit until the error condition is cleared, either through a hardware or software reset, or by reading the error out with the Q command.

**ENB**

A lit Enable LED indicates the output drivers are enabled.

**R9 - R0**

These LEDs indicate the state of each relay driver (Least Significant Digit) of the currently displayed MSD. The LED being lit indicates the bit is active (pulled low). An unlit LED indicates the relay driver is not active (tri-stated). R9 is the most significant relay driver and R0 the least significant relay driver of the selected MSD.

**BITE (Built-In Test Equipment)**

BITE is provided on the module by an internal loop-back path, which allows the module to be tested with the outputs disabled. The self test automatically tests and verifies all loop-back paths for each byte.

Self test is automatically performed on power-up, and can also be commanded. All the outputs are checked with the output drivers disabled.

Front panel LEDs indicate the status of power, backplane cycles, module failure, programming errors, output driver status, and individual output drivers. In addition, the Query command can be used to determine the current state of the module during operation, including error codes (see the Query command in the Command Descriptions subsection).



# SPECIFICATIONS

---

Number of Output Channels:	80.
Configuration:	80 open collector outputs.
Each Transistor Collector-Emitter Saturation Voltage:	0.5V max at $I_c = 300$ mA.
Max. Collector Current ( $I_c$ ):	300 mA.
Max. Switching Voltage:	50V resistive, 35V inductive.
Max. Total Switching Current:	20 Amps.
Output Driver:	Sprague UDN-2596A.
Relay Control:	May be controlled individually, in banks of eight, or all 80 simultaneously (C or O commands, CB or OB commands, or L command).
Command-to-Output Delays (typical):	C and O commands: 400 $\mu$ s. CB and OB commands: 250 $\mu$ s. L command: 180 $\mu$ s.
VXIbus TTL Trigger-to-Output Delay:	1 $\mu$ s typical.
Command to VXIbus TTL Trigger Output:	T command: 100 $\mu$ s typical.
VXIbus TTL Trigger Pulse Width:	3 $\mu$ s typical.
Output Control:	On program command, a VXIbus TTL trigger line, or an IEEE Group Execute Trigger.
Output Enable Control:	On program command, all outputs may be enabled or disabled (tri-stated).
Interrupt Modes:	Program selectable, on programming error, and/or external trigger (VXIbus TTL trigger line input, or an IEEE Group Execute Trigger).
VXIbus Compatibility:	Fully compatible with the VXIbus Specification for message-based instruments with the Halt switch in the ON position.

VXI Device Type:	VXI message based instrument, Revision 1.3.
VXI Protocol:	Word serial.
VXI Module Size:	C size, one slot wide.
Module-Specific Commands:	All module-specific commands and data are sent via the VXIbus Byte Available command. All module-specific commands are made up of ASCII characters. Module-specific data may be in either ASCII or binary format.
VMEbus Interface:	Data transfer bus (DTB) slave - A16, D16 only.
Interrupt Level:	Switch selectable, levels 1 (highest priority) through 7 (lowest).
Interrupt Acknowledge:	D16, lower 8 bits returned are the logical address of the module.
VXIbus ACFAIL*:	Disables all outputs when activated.
VXIbus Data Rate:	Write: 20 Kbytes/sec maximum. Read: 400 Kbytes/sec maximum.
VXIbus Commands Supported:	All VXIbus commands are accepted (e.g. DTACK* will be returned). The following commands have effect on this module; all other commands will cause an Unrecognized Command Event: <ul style="list-style-type: none"> <li>BYTE AVAILABLE (with or without END bit set)</li> <li>BYTE REQUEST</li> <li>BEGIN NORMAL OPERATION</li> <li>READ PROTOCOL</li> <li>READ STATUS</li> <li>CLEAR</li> <li>TRIGGER</li> <li>* GRANT DEVICE</li> <li>* SET LOCK</li> <li>* CLEAR LOCK</li> <li>* IDENTIFY COMMANDER</li> </ul> <p>* These commands are accepted, but have no effect on the module.</p>
VXIbus Protocol Events Supported:	VXIbus events are returned via VME interrupts. The following events are supported and returned to the 73A-308 Module's commander: <ul style="list-style-type: none"> <li>REQUEST TRUE (In IEEE-488 systems such as the 73A-155, this interrupt will cause a Service Request (SRQ) to be generated on the IEEE-488 bus.</li> </ul>

<b>VXIbus Registers:</b>	<p>ID  Device Type  Status  Control  Protocol  Response  Data Low  See Appendix A for definition of register contents.</p>
<b>Device Type</b>	
<b>Register Contents:</b>	FECB (ones complement of binary value of model number).
<b>Power Requirements:</b>	All required dc power is provided by the Power Supply in the VXIbus card cage.
<b>Voltage:</b>	+5 Volt Supply: 4.75V dc to 5.25V dc.
<b>Current (Peak Module, I<sub>PM</sub>):</b>	5 volt supply: 2.0 A.
<b>Power-up Defaults:</b>	<p>All relay driver outputs disabled.  VXIbus external triggers disabled.  Non-buffered mode.  Request True interrupts disabled.  Wait hold off disabled.</p>
<b>Fuses:</b>	Replacement fuse: Little Fuse P/N 273004
<b>Cooling:</b>	Less than 10°C temperature rise with TBD liters/sec. of air at a pressure drop of TBD mm of H <sub>2</sub> O.
<b>Temperature:</b>	<p>0°C to +50°C, operating .  -40°C to +85°C, storage.</p>
<b>Humidity:</b>	<p>Less than 95% R.H. non-condensing, 0°C to +30°C.  Less than 75% R.H. non-condensing, +31°C to +40°C.  Less than 45% R.H. non-condensing, +41°C to +50°C.</p>
<b>VXI Bus Radiated Emissions:</b>	Complies with VXIbus Specification.
<b>VXI Bus Conducted Emissions:</b>	Complies with VXIbus Specification.
<b>Module Envelope</b>	
<b>Dimensions:</b>	VXI C size. 262 mm x 353 mm x 30.5 mm (10.3 in x 13.9 in x 1.2 in)
<b>Dimensions, Shipping:</b>	<p>When ordered with a CDS card cage, this module will be installed and secured in one of the instrument module slots (slots 1 - 12).</p> <p>When ordered alone, the module's shipping dimensions are:</p>

406 mm x 305 mm x 102 mm.  
(16 in x 12 in x 4 in).

<b>Weight:</b>	1.9 kg. (4.2 lbs.)
<b>Weight, Shipping:</b>	When ordered with a CDS card cage, this module will be installed and secured in one of the instrument module slots (slots 1-12).  When ordered alone, the module's shipping weight is: 2.4 kg. (5.2 lb).
<b>Mounting Position:</b>	Any orientation.
<b>Mounting Location:</b>	Installs in an instrument module slot (slots 1-12) of a C or D size VXIbus card cage. (Refer to D size card cage manual for information on required adapters.)
<b>Front Panel Signal Connectors:</b>	2 - 50 pin (DD50P) connector, pin. Refer to Appendix B for connector pinouts.
<b>Recommended Cable:</b>	73A-642 Analog Cable (2 required for all 80 relay drivers).
<b>Equipment Supplied:</b>	1 - 73A-308 Module.
<b>Software Revision:</b>	V1.4

# INSTALLATION

---

## INSTALLATION REQUIREMENTS AND CAUTIONS

The 73A-308 Module is a C size VXIbus instrument module and therefore may be installed in any C or D size VXIbus card cage slot other than slot 0. If the module is being installed in a D size card cage, consult the operating manual for the card cage to determine how to install the module in that particular card cage. Setting the module's Logical Address switch defines the module's programming address. Refer to the Controls and Indicators subsection for information on selecting and setting the 73A-308 Module's logical address.

### CAUTION:

To avoid confusion, it is recommended that the slot number and the logical address be the same.

### Tools Required

The following tools are required for proper installation:

Slotted screwdriver set.

### CAUTION:

Note that there are two ejector handles on the card. To avoid installing the module incorrectly, make sure the ejector labeled "73A-308" is at the top.

### CAUTION:

In order to maintain proper card cage cooling, unused card cage slots must be covered with blank front panels supplied by the card cage manufacturer. Based on the number

of IAC Modules ordered with a CDS card cage, blank front panels are supplied to cover all unused slots.

### CAUTION:

Verify that the card cage is able to provide adequate cooling and power for the 73A-308 Module. Refer to the card cage Operating Manual for instructions on determining cooling and power compatibility.

### CAUTION:

If the 73A-308 Module is inserted in a slot with any empty slots to the left of the module, the VME daisy-chain jumpers must be installed on the backplane in order for the 73A-308 Module to operate properly. Check the manual of the card cage being used for jumpering instructions.

If a CDS 73A-021 Card Cage is being used, the jumper points may be reached through the front of the card cage. There are five (5) jumpers that must be installed for each empty slot. The five jumpers are the pins to the left of the empty slot.

## INSTALLATION PROCEDURE

### CAUTION:

The 73A-308 Module is a piece of electronic equipment and therefore has some susceptibility to electrostatic damage (ESD). ESD precautions must be taken whenever the module is handled.

- 1) Record the module's Revision Level, Serial Number (located on the CDS label on the top shield of the 73A-308), and switch settings on the Installation Checklist on the next page. Only qualified personnel should install the 73A-308 Module.
- 2) Verify that the Logical Address and Interrupt Level switches are switched to the correct values. The Halt switch should be in the ON position unless it is desired to not allow the resource manager to reset this module.

Note that with either Halt switch position, a "hard" reset will occur at power-up and when SYSRST\* is set true on the VXibus backplane. If the module's commander is a CDS 73A-155 RM/IEEE-488 Interface Module, SYSRST\* will be set true whenever the Reset switch on the front panel of the 73A-155 is depressed. Also note that when the Halt switch is in the OFF position, the module is not in strict compliance with the VXibus Specification.

- 3) The module can now be inserted into any slot of the chassis other than slot 0.
- 4) Installation of Cables:

If the module is being installed in a CDS 73A Series card cage, route the cables from the front panel of the

module down through the cable tray at the bottom of the card cage and out the rear of the card cage. Connect the cable to the 73A-308 Module's P4/PS interfaces.

If a special cable is needed, 73A-780S and 73A-82P Hooded Connectors may be used to cable between the module's output connectors and the UUT.

### Clamp Lines

The charts below show the connections for the clamp line jumpers on the P4 and P5 connectors (see also Figure 308-1A). The 73A-308 has four different clamp (suppression diode) lines, two for each P-connector. Individual banks of drivers may be connected to either of the two clamp lines (pins 17 and 50) of the P connector. Bank 0 to 4 (relay drivers 0 to 39) use the P4 connector. Bank 5 to 9 (relay drivers 40 to 79) use the P5 connector. Each bank of eight relay drivers may be selected to either pin 50 or pin 17 of its corresponding connector. Refer to Appendix B for output connections that correspond to clamp lines.

### P4 Clamp Selection

Top of Board				
	Bank	A	B	C
W4	4	o	o ---- o	o
W3	3	o	o ---- o	o
W2	2	o ---- o	o	o
W1	1	o ---- o	o	o
W0	0	o ---- o	o	o

A - P4 Pin 50  
 B - bank of 8 relay drivers  
 C - P4 Pin 17

Default settings are shown.

### P5 Clamp Selection

	Bank	A	B	C
W9	9	o	o ---- o	o
W8	8	o	o ---- o	o
W7	7	o ---- o	o	o
W6	6	o ---- o	o	o
W5	5	o ---- o	o	o

Bottom of board

A - P5 pin 50  
B - bank of 8 relay drivers  
C - P5 pin 17

Default settings are shown.

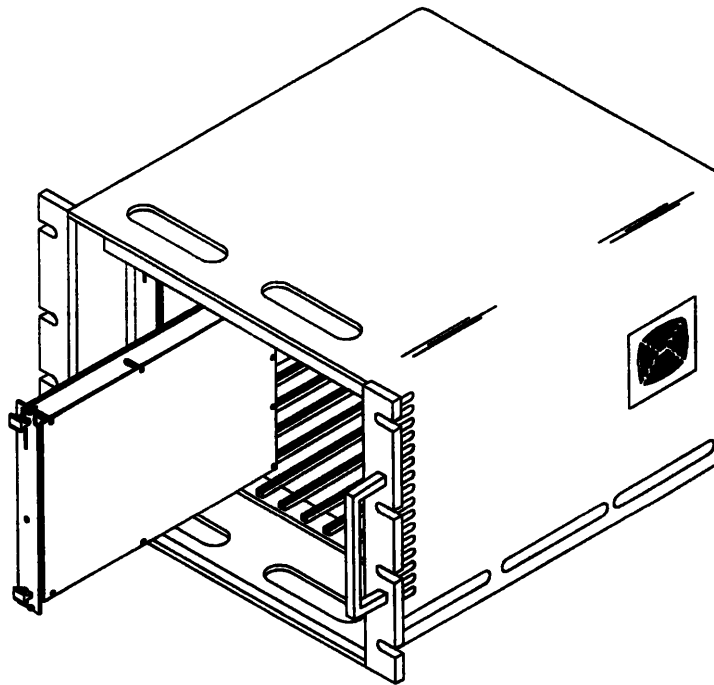

*Figure 3: Module Installation*

# INSTALLATION CHECKLIST

Installation parameters may vary depending on the card cage being used. Be sure to consult the card cage Operating Manual before installing and operating the 73A-308 Module.

Revision Level: \_\_\_\_\_

Serial No.: \_\_\_\_\_

Card Cage Slot Number: \_\_\_\_\_

### Switch Settings:

VXIbus Logical Address Switch: \_\_\_\_\_

Interrupt Level Switch: \_\_\_\_\_

Halt Switch: \_\_\_\_\_

### Clamp Lines:

\_\_\_ Default settings retained

\_\_\_ Changed to:

P4 \_\_\_\_\_

P5 \_\_\_\_\_

### Cabling Installed:

P4 Cable: \_\_\_\_\_

P5 Cable: \_\_\_\_\_

Performed by: \_\_\_\_\_ Date: \_\_\_\_\_



# OPERATION

---

## OVERVIEW

The 73A-308 Module is programmed by ASCII characters issued from the system controller to the 73A-308 Module via the module's VXibus commander and the VXibus card cage backplane. The module is a VXibus Message Based instrument and communicates using the VXibus Word Serial Protocol. Refer to the manual for the VXibus device that will be the 73A-308 Module's commander for details on the operation of that device.

If the module is being used in a CDS 73A-IBX System card cage, the module's commander will be the 73A-155 Resource Manager/IEEE-488 Interface Module. Refer to the 73A-155 Operating Manual and the programming examples in the Operation section of this manual for information on how the system controller communicates with the 73A-155.

## POWER-UP

The 73A-308 Module will complete its self test and be ready for programming five seconds after power-up. The VXibus Resource Manager may add an additional one or two second delay to this time. The Power LED will be on, and the Failed LED off. The MSG LED will blink during the power-up sequence as the VXibus Resource Manager addresses all modules in the card cage. The default condition of the module after power-up is described in the SYSFAIL, Self Test and Initialization subsection.

## SYSTEM COMMANDS

Although these non-data commands are initiated by the 73A-308's commander (for example, the 73A-155 Module in a CDS 73A-IBX System) rather than the system controller, they have an effect on the 73A-308 Module. The following VXibus Instrument Protocol Commands will affect the 73A-308:

<u>Command</u>	<u>Effect</u>
Clear	The module clears its VXibus interface and any pending commands. Current module operations are unaffected.
Trigger	The trigger command will latch data to the outputs if enabled.
Begin Normal Operation	The module will accept programming commands.
Read Protocol	The module will return its protocol features to its commander.
Read Status	The module will return its status to its commander.

## MODULE COMMANDS

A summary of the 73A-308's Module's commands is listed below. This is followed by detailed descriptions of each of the commands. A sample BASIC program using

these commands is shown at the end of this section.

Command protocol and syntax for the 73A-308 Module is as follows:

- 1) Each command consists of a string of up to 255 characters. Every command must end with either a line-feed <LF> or a semi-colon (;) delimiter, shown in the command descriptions as <tm>. A <CR> is treated as a white space character, and is ignored if received.
- 2) All commands are operated on in the order they are received, and executed when the delimiter is received.
- 3) If a given parameter is omitted within a command, either its default state or its last programmed state will be in effect (depending on the particular command issued).
- 4) Any character may be sent in either upper or lower case form.
- 5) Any of the following white space characters, whose 8-bit hexadecimal values are given below, are allowed within the command string, and are ignored by the module:  
00-09, 0B-20, 80-89, 8B-90
- 6) Any command syntax or programming errors will cause the command to be ignored, and an error will be flagged. All commands up to the occurrence of the error will remain valid. The invalid command will be lost, and all following valid commands will be accepted. The error condition can be cleared either through a hardware or software reset, by reading the error out with the Q command, or taking an unprogrammed readback.
- 7) All responses from the module are terminated by a carriage return and line-feed <CR><LF>.

- 8) A command may be issued in either the full format or the short format. The short form is useful when a number of commands are sent in a single string.

#### • Command Summary

Detailed descriptions of each command (in alphabetical order) are given following the summary. An overview of the commands is as follows:

- BD BUFFER DISABLE - puts the module in non-buffered mode (default condition).
- BE BUFFER ENABLE - puts the module in Buffered mode.
- C CLOSE - allows the system controller to close or activate a single relay driver.
- CB CLOSE BANK - allows the system controller to close a bank of eight relay drivers.
- D DISABLE - disables the sink drivers. (default condition)
- E ENABLE - enables the sink drivers.
- I INTERRUPT - used to enable or disable the VXibus Request True interrupt. This interrupt can be programmed to be active when an error occurs, or when a trigger is received, or when any combination of these occurs.
- L LOAD - Performs a parallel load of ASCII hex data representing all 80 relay drivers. This command overrides all outputs.
- O OPEN - allows the system controller to open or deactivate a single relay driver.

- OB OPENBANK - allows the system controller to open a bank of eight relay drivers.
- Q QUERY - used to read the current state of the module. The information available includes:
- error data
  - the trigger setup programmed
  - trigger status, whether trigger has occurred
  - driver status (enabled or disabled)
  - output status (driver active or inactive)
- R RESET - resets the board to its power-up state.
- S SELFTEST - causes the module to execute a self test, and then return to its previously programmed state, before the self test was executed.
- T TRIGGER - pulse a VXibus TTL trigger line specified by the TRIGGER SETUP command.
- TS TRIGGER SETUP - sets up external triggers: Trigger Inputs are either VXibus TTL triggers or IEEE Group Execute Trigger. Trigger Outputs are VXibus TTL triggers.
- V VERSION - returns the current software revision level of the board.
- W WAIT - waits for a specified number of 1 ms intervals, to allow relays to close before any more commands may be accepted by the 73A-308.

*NOTE:*

The (), {}, ' ', and ... characters are not part of the command.

A detailed description of each command, in alphabetical order, is given on the following pages. The syntax used in the command descriptions is:

- ( ) optional parameter
- { } group of parameters
- ' ' ASCII character
- ... optional repetition

## • Command Descriptions

Command: BUFFER DISABLE or BD

Syntax: BUFFER DISABLE<TM>  
BD<TM>

Purpose: This command puts the module into the Nonbuffered mode of operation.

Description: In the Nonbuffered mode, a byte of command/data is not accepted from the VXibus until the previous character has been processed. By using this mode, the 73A-308 maintains synchronization with its commander, and the user knows when the commands have been completed. For example, if <CR><LF> is used as a terminator, it is guaranteed that the relay drivers programmed will be activated when the <LF> is accepted.

The major advantage of this method is that another module which may use relay drivers from the 73A-308 can immediately be programmed after the 73A-308. Consult the Synchronizing Multiple Instrumentation Modules section for more details.

*NOTE:* The following paragraph only applies to the programmer who will be switching back and forth between Buffered and Nonbuffered modes.

It is important to note that since this command typically will be received while the module is in the Buffered mode, it will not take effect until the processor has parsed it (receiving characters and processing them occur independently in buffered mode). To guarantee that the module is actually in Nonbuffered mode before executing another command, a query command (i.e. QER or V) should be sent to the 73A-308 after the BUFFER DISABLE command and the result read. This will re-synchronize the module and the controller, since the response to the query is not returned until both the BUFFER DISABLE and QER or V commands have been processed.

Default: Nonbuffered mode.

Example: BUFFER DISABLE<TM>  
BD<tm> Both commands disable the 73A-308 from buffered mode.

**Command:** BUFFER ENABLE or BE

**Syntax:** BUFFER ENABLE<TM>  
BE<TM>

**Purpose:** This command allows the system controller to send data and commands to the 73A-308 over the VXIbus at optimum speed, independent of the parsing and execution speed of this module. Default is that the buffers are disabled.

**Description:** In the Buffered mode, all data sent to the module is buffered before being parsed, allowing much faster transfer rates. This module operates using the VXIbus Fast Handshake mode while in buffered mode. See the Synchronizing Multiple Instrumentation Modules section for details on synchronizing multiple modules used in the Buffered mode. The module can take in up to 8192 characters at the 400 Kbyte rate before it has to temporarily hold off the VXIbus.

**NOTE:** The following discussion applies only to users planning on sending extremely large amounts of data in a very short period of time.

If you plan on sending 4000 bytes of data in under 200 milliseconds in Buffered mode (which roughly corresponds to 50  $\mu$ s/character), the data will be received faster than the 73A-308's parser is able to process the characters, and eventually the module's 8192-byte buffer will fill up. This will cause a temporary VXIbus hold off condition, which is transparent except for the effect it has on data transfer speed. If the IEEE-488 controller is slower than the module's parser rate, as many are, this hold off condition would never be encountered.

When the hold off situation occurs, the 73A-308 will not allow the VXIbus system controller to send any additional data until the parser has emptied half of its input buffer.

As an example, the first time the 8192-byte buffer is filled, the system controller will be held off until the first 4096 bytes are parsed. From this point on, every time the module releases the hold off condition, the controller may send another 2048 bytes, at which time it has to wait on the parser again.

Each character sent takes up one byte in the module input buffer unless the END bit is set (EOI for IEEE-488), in which case it takes up three bytes. All buffered VXIbus commands (Trigger, Set Lock, Clear Lock) take up three bytes. (The VXIbus commands Clear and Read Status are not buffered.) Refer to the 73A-308 commander's manual for information on generation of VXIbus commands. If the module is being used in a CDS 73A-IBX System, the 73A-155 is its commander.

**Default:** Nonbuffered mode.

**Example:** BUFFER ENABLE<TM> Enable the Input buffer on the 73A-308.

**Command:** CLOSE or C

**Syntax:** CLOSE z<tm>  
C z<tm>

**Purpose:** The Close command closes an individual relay driver line.

**Description:** z a number 0 through 79 which specifies the relay driver number to activate. The least significant relay driver is output control line 0. Relay driver 1 is control line 1, etc., and the most significant relay driver 79 is control line 79. Refer to the table in Appendix B which shows the driver numbers that correspond to control lines and output pins.

The Close command allows the 73A-308 to close the individual relay driver line specified by the z parameter.

The Trigger Setup (TS) command affects the operation of this command. If the TS command is specified to monitor an external trigger, then the C command will be latched to the relay drivers when the trigger is received. See the Trigger Setup command for a full description.

**NOTE:** The ENABLE (E) command must be sent to activate any drivers programmed by the C command. The E command only needs to be sent once.

**Default:** (not specified)

**Example:** CLOSE 1<tm> - activates relay driver 1. (Pin 36 of P4 will be activated.)  
CLOSE 7<tm> - activates relay driver 7. (Pin 1 of P4 will be activated.)

**Errors:** If the z parameter is not within the specified range of 0 to 79, an Invalid Channel Number error will be generated. This error will turn on the module's Error LED and generate a VXibus Request True event (if Interrupt On Error has been enabled with the I command). Refer to the I command for a complete description of the 73A-308 interrupts and to the QER command for error codes and messages.

Command: CLOSEBANK or CB

Syntax: CLOSEBANK z<tm>  
CB z<tm>

Purpose: The Close Bank command closes a bank of eight relay drivers.

Description: z a number 0 through 9, which specifies the bank of eight drivers to be activated. The least significant bank is control lines 0-7. Bank 1 is control lines 8-15, etc., and the most significant bank is control lines 72-79. Refer to the table in Appendix B which shows the bank numbers that correspond to control lines and output pins.

The Close Bank command allows the 73A-308 to close a bank of eight relay drivers lines specified by the z parameter.

The Trigger Setup (TS) command affects the operation of this command. If the TS command is specified to monitor an external trigger, then the CB command will be latched to the relay drivers when the trigger is received. See the Trigger Setup command for a full description.

*NOTE:* The ENABLE (E) command must be sent to activate any drivers programmed by the C command. The E command only needs to be sent once.

Default: (not specified)

Example: CLOSEBANK 0<tm> - activates drivers 0 to 7.  
CB 5<tm> - activates drivers 40 to 47.

Errors: If the z parameter is not within the specified range of 0 to 9, an Invalid Bank Number error will be generated. This error will turn on the module's Error LED and generate a VXIbus Request True event (if Interrupt On Error has been enabled with the I command). Refer to the I command for a complete description of the 73A-308 interrupts and to the QER command for error codes and messages.

**Command:** DISABLE or D

**Syntax:** DISABLE<tm>  
D<tm>

**Purpose:** The Disable command disables all relay drivers.

**Description:** Upon receipt of this command, all outputs will be disabled (high impedance). This command simply disables all relay drivers, without affecting any previous command. All C, O, CB, OB, and L commands sent to the 73A-308 will not affect the output drivers, but will be latched to the outputs. This means that the user may close other channels before enabling all relay drivers.

**Default:** All outputs disabled.

**Example:** Both of the following commands disable all relay drivers:  
DISABLE<tm>  
D<tm>



**Command:** ENABLE or E

**Syntax:** ENABLE<tm>  
E<tm>

**Purpose:** The Enable command sets all relay drivers active.

**Description:** All outputs will be enabled on receipt of this command. All C, O, CB, OB, and L commands sent to the 73A-308 prior to this command will be activated. This command only needs to be sent once, unless overridden by a Disable or Reset command.

**Default:** All outputs disabled.

**Example:** Both of the following commands enable all programmed relay drivers:

ENABLE<tm> - turns on all outputs previously or immediately programmed.  
E<tm> - turns on all outputs previously or immediately programmed.

**Command:** INTERRUPT or I

**Syntax:** INTERRUPTz<tm>  
Iz<tm>

**Purpose:** The Interrupt command is used to enable and disable VXibus Request True interrupts on either an error or an external trigger.

**Description:** z one of the following letters which specifies interrupt conditions:  
 E enable interrupt on programming error.  
 T enable interrupt on an external trigger (see TS command).  
 \* enable interrupt on either an external trigger or programming error.  
 D disables all interrupts.

A parameter must be specified, and once programmed, the setup remains valid unless specifically overridden by another I command or by a Reset. If there is an error pending and the IE command is issued, a VXibus Request True interrupt will occur.

When a VXibus Read Status command is sent to the 73A-308, the module will set bit 6 of the returned status byte if the Request True Interrupt has been generated.

In IEEE-488 controller applications, the Request True interrupt is used to generate an IEEE-488 Service Request (SRQ).

**Default:** interrupts disabled

**Examples:** IE<tm> interrupts when a programming error occurs  
 IT<tm> interrupts when an external trigger occurs  
 INTERRUPT\*<tm> interrupts either on an external trigger or a programming error  
 ID<tm> disables all interrupts

**Errors:** If the z parameter is not one of the specified parameters, an Invalid Interrupt Command error will be generated. This command will turn on the module's Error LED and generate a VXibus Request True event (if Interrupt On Error has been enabled with the I command). Refer to the QER command for error code information.

**Command:** LOAD or L

**Syntax:** LOAD(R<sub>19</sub>... R<sub>0</sub>)  
L(R<sub>19</sub>... R<sub>0</sub>)

**Purpose:** The Load command allows the user to latch hex data bytes to the relay drivers.

**Description:** R is a hex digit from 0 to F. Each of the hex digits controls four output lines. R<sub>0</sub> is the LSB, and R<sub>19</sub> is the MSB. All 20 digits must be sent to the 73A-308. This parallel load is a quick way to put data to the relay drivers. This command will override any existing drivers that have been activated or deactivated. See Appendix B for a full description of the R digit in relation to the hex digit that corresponds to the output pin connectors.

The Trigger Setup (TS) command affects the operation of this command. If the TS command is specified to monitor an external trigger line, then the L or Load command will be latched to the output drivers when the trigger is received. See the Trigger Setup command for a full description.

**NOTE:** The ENABLE (E) command must be sent to activate any drivers programmed by the LOAD (L) command. The E command only needs to be sent once.

**Default:** Not defined.

**Example:** LOADFF00550000FFFF55AA01<tm>

This command closes relay drivers 0, 9, 11, 13, 15, 16, 18, 20, 22, 24, 25, 26, 27, 28, 29, 30, 31, 32, 33, 34, 35, 56, 58, 60, 62, 72, 73, 74, 75, 76, 77, 78, and 79, so they are all active.

L000000000000000000000000<tm>

This command opens all relay drivers.

**Errors:** If the R parameter is not within the specified range of 0 to F, an Invalid (or Missing) Hex Value error will be generated.

If an incorrect number of digits (anything other than 20) is specified, an Invalid Load Command - Wrong Number of Characters error will be generated.

Both of these errors will turn on the module's Error LED and generate a VXIbus Request True event (if Interrupt On Error has been enabled with the I command). Refer to the QER command for error code information and to the I command for a description of the 73A-308's interrupts..

**Command:** OPEN or O

**Syntax:** OPEN z<tm>  
O z<tm>

**Purpose:** The Open command opens an individual relay driver line.

**Description:** z a number 0 through 79 which specifies the relay driver number to deactivate. The least significant relay driver 0 is control line 0, relay driver 1 is control line 1, etc., and the most significant relay driver 79 is control line 79. Refer to the table in Appendix B which shows the driver numbers that correspond to control lines and output pins.

The Open command allows the 73A-308 to open the individual relay driver control line specified by the z parameter.

The Trigger Setup (TS) command affects the operation of this command. If the TS command is specified to monitor an external trigger, then the O command will be latched to the relay drivers when the trigger is received. See the Trigger Setup command for a full description.

**Default:** Not defined.

**Example:** OPEN 1<tm> - deactivates relay driver 1. (Pin 36 of P4)  
OPEN 7<tm> - deactivates relay driver 7. (Pin 1 of P4)

**Errors:** If the z parameter is not within the specified range of 0 to 79, an Invalid Channel Number error will be generated. This error will turn on the module's Error LED and generate a VXIbus Request True event (if Interrupt On Error has been enabled with the I command). Refer to the I command for a complete description of the 73A-308 interrupts and to the QER command for error codes and messages.

Command: OPENBANK or OB

Syntax: OPENBANK z<tm>  
OB z<tm>

Purpose: The Open Bank command opens a bank of eight drivers.

Description: z a number 0 through 9 which specifies the bank of drivers to deactivate. The least significant bank is control lines 0 to 7, bank driver 1 is control lines 8 to 15, etc., and the most significant bank is control lines 72 to 79. Refer to the table in Appendix B which shows the bank numbers that correspond to control lines and output pins.

The Open Bank command allows the 73A-308 to open a bank of eight relay drivers specified by the z parameter.

The Trigger Setup (TS) command affects the operation of this command. If the TS command is specified to monitor an external trigger line, then the OB command will be latched to the relay drivers when the trigger is received. See the Trigger Setup command for a full description.

Default: Not defined.

Example: OPENBANK 1<tm> - deactivates drivers 0 to 7.  
OB 5<tm> - deactivates drivers 40 to 47.

Errors: If the z parameter is not within the specified range of 0 to 9, an Invalid Bank Number error will be generated. This error will turn on the module's Error LED and generate a VXibus Request True event (if Interrupt On Error has been enabled with the I command). Refer to the I command for a complete description of the 73A-308 interrupts and to the QER command for error codes and messages.

**Command:** QUERY or Q

**Syntax:** QUERY(z)  
Q(z)

**Purpose:** The Query command returns the status of various hardware and software states.

**Description:** z is one of the following ASCII strings which specifies what is to be returned:

- ER - Returns the current Error (see Error Responses below). If there are no errors, a 'NO ERRORS' response will be returned.
- EN - Status of the all output bytes: 1 = drivers Enabled; 0 = drivers disabled.
- RB - Reads back the programmed state of all relay drivers. The ASCII data returned is 20 hex bytes. Refer to Appendix B for a byte-to-output pin description.
- TS - Returns the trigger setup information.
- TG - Returns the current external Trigger status, if an external trigger has occurred: 0 = no trigger; 1 = trigger occurred. This command will return a 1 if any external triggers have been received prior to this command being issued. (See the TS command for external trigger explanation.)
- 0-79 - returns the output status of the specified driver: 0 = output disabled, 1 = output enabled.

If an error is queued, the module's Error LED will be lit until a QER command or an uncommanded readback is issued. If there are no errors, the module will respond with 'READY'. The error responses are listed below.

**Examples:** The following examples show how each of the above commands will respond on power-up:

1. QUERY ER<tm> returns an ASCII string with an explanation of the error that occurred. 'NO ERRORS<tm>' will be returned if no errors occurred, or when the last error has been read back.
2. QEN<tm> returns '1<tm>' if outputs are enabled and '0<tm>' if outputs are disabled.
3. If the following two commands are sent in sequence,
  - TS 0,D<tm> sets up the 73A-308 to monitor VXibus TTL trigger line 0 (see the TS command).
  - CLOSE 1<tm> closes relay driver 1.
  - then
  - QUERY RB<tm> returns 00000000000000000000<tm>
 When VXibus TTL trigger line 0 is pulsed,  
 QUERY RB<tm> returns 00000000000000000002<tm>

If the 73A-308 is set up to monitor a VXibus TTL trigger (TS command) and the following command is sent

LOADFF005500FFAA00000055<tm>

it loads the data into the latches. The data will not go to the outputs until a VXibus TTL TRIGGER occurs.

If the command

QUERY RB<tm>

is sent before a VXibus TTL trigger is received, the module will return 00000000000000000000<tm>

If the command

QUERY RB<tm>

is sent after a VXibus TTL trigger, the module will again return FF005500FFAA00000055<tm>

4. TS 0,D<tm> sets up an external trigger monitor condition (VXibus TTL trigger line 0).

QUERY TS<tm> returns 0,D<tm> (monitors VXibus TTL trigger line 0, card disable external trigger outputs)

QUERY TG returns "0<tm>" if a VXibus TTL trigger has not occurred on line 0 (provided the TS command above was given). It returns a "1<tm>" if a VXibus TTL trigger occurred.

5. CLOSE 1<tm> activates output driver 1.

QUERY 1<tm> returns a "1<tm>"

OPEN 1<tm> deactivates output driver 1.

QUERY 1<tm> returns a "0<tm>"

#### Error

Responses:

<u>Number</u>	<u>Error Message</u>
0	NO ERRORS
1	SELF TEST FAILURE (BANK X BIT - B DATA Y-Z) where X is an ASCII 0 through 9 indicating the bank which failed self test, B is an ASCII digit 0 to 7 indicating the bit that failed, Y is an ASCII 0 or 1 indicating the data written to the bank, and Z is an ASCII 0 or 1 indicating the data that was read back.
2	SYNTAX ERROR
3	INPUT BUFFER OVERFLOW
4	TOO MANY DIGITS IN EXPONENT
5	TWO DECIMAL POINTS WITHIN NUMBER
6	INVALID CHANNEL NUMBER 'X'

7                   where X is the invalid number.  
INVALID TRIGGER COMMAND  
8                   where X is the invalid character.  
INVALID QUERY COMMAND 'X'  
                  where X is the invalid character.  
9                   INVALID LOAD COMMAND - WRONG NUMBER OF  
CHARACTERS 'X'  
                  where X is the number of characters received.  
10                  INVALID (OR MISSING) HEX VALUE 'X'  
                  where X is the invalid hex character.  
11                  INVALID INTERRUPT COMMAND 'X'  
                  where X is the invalid character.  
12                  MAXIMUM SEQUENCE LENGTH EXCEEDED - XX  
                  where XX is the length of the sequence (up to six  
                  sequence numbers are valid).  
13                  INVALID BANK NUMBER 'X'  
                  where X is the invalid number.  
14                  INVALID WAIT VALUE 'X'  
                  where X is the invalid wait number.  
15                  UNKNOWN ERROR



Command:       RESET or R

Syntax:         RESET<tm>  
                  R<tm>

Description:    The Reset command resets the board to its power-up state:

                  All pins open or high impedance.  
                  Request True interrupts disabled.  
                  All output drivers disabled.  
                  All VXibus TTL triggers disabled.  
                  All pending programming errors are cleared.  
                  Non-buffered mode.  
                  Wait command disabled.

Examples:       Both of these commands reset the module to power-up conditions:

                  RESET<tm>  
                  R<tm>

Command: SELFTEST or S

Syntax: SELFTEST<tm>  
S<tm>

Purpose: The Self Test command causes the module to execute a self test, and then return to its previously programmed state.

Description: The self test consists of internal circuitry tests, and wraparound tests. All output drivers will be disabled during the self test, and then the module will be returned to its previous state when the self test is finished. The results of a self test can be read using the query command QER. If the self test fails, error '1' will be generated, and the module's Failed LED will be lit. Refer to the Query command for more information on error codes.

*NOTE:* The self test will not affect any programmed commands. However, the outputs will be disabled during the self test.

Default: Not defined.

Examples: Both of the following commands will perform a self test:  
SELFTEST<tm>  
S<tm>

**Command:** TRIGGER or T

**Syntax:** TRIGGER<tm>  
T<tm>

**Purpose:** Pulse a VXIbus TTL trigger line.

**Description:** The Trigger command will pulse a VXIbus TTL trigger line specified by the Trigger Setup command. If this command is issued and a VXIbus TTL trigger line has not been specified by the TS command, then this command will have no effect on the VXIbus TTL trigger lines.

**Default:** Disabled. (See TS command.)

**Example:** TRIGGER SETUP 0,3<tm> sets the 73A-308 to monitor VXIbus TTL trigger line 0 and to output on trigger line 3.

TRIGGER<tm> pulses VXIbus TTL trigger line 3 (the line specified by the above TRIGGER SETUP command).

**Command:** TRIGGER SETUP or TS

**Syntax:** TRIGGER SETUP x,y<tm>  
TS x,y<tm>

**Purpose:** This command sets up which external trigger the 73A-308 will monitor (VXIbus TTL trigger line or IEEE-488 Group Execute Trigger) and which VXIbus TTL trigger output line it will output on.

**Description:**

- x specifies the trigger in condition. Valid values for x are:
  - 0 - 7 specifies the VXIbus TTL trigger line to monitor.
  - D disable the 73A-308 from monitoring either a VXIbus TTL trigger line or an IEEE-488 Group Execute Trigger.
  - G selects an IEEE Group Execute Trigger.
- y specifies the VXIbus TTL trigger OUT. Valid values for y are:
  - 0 - 7 specifies the VXIbus TTL trigger line to be driven.
  - D disable the 73A-308 from monitoring a VXIbus TTL trigger line.

The x and y parameters remain valid until overridden by another TS command or a Reset command.

When the 73A-308 is set up to monitor a VXIbus TTL trigger line or an IEEE Group Execute Trigger, all C, O, CB, OB, and L commands sent to the 73A-308 will latch to the outputs when the specified VXIbus TTL trigger line is pulsed or when the IEEE Group Execute Trigger command is executed. Only one VXIbus TTL trigger line can be monitored at a time. The 73A-308 may also be set up to pulse a VXIbus TTL trigger line when issued a T or TRIGGER command. The IEEE Group Execute Trigger command is only valid for the Trigger In value.

**Default:** Trigger IN/OUT disabled.

**Example:** TRIGGER SETUP 2,4<tm> sets the 73A-308 to monitor TTL trigger line 2 and to output on trigger line 4.

TRIGGER SETUP 2,2<tm> sets the 73A-308 to monitor and to output a VXIbus TTL trigger on line 2. When a VXIbus TTL trigger is received, the output of the 73A-308 will be latched to the outputs. This will also allow a Trigger (T) command to pulse out a VXIbus TTL trigger and trigger itself.

TS G,0<tm> The first parameter 'G' sets the 73A-308 to latch outputs when an IEEE Group Execute Trigger is received. The second parameter sets the VXIbus TTL trigger line to output at 0. So when a T or TRIGGER command is issued, VXIbus TTL trigger line 0 will be pulsed.

TS D,D<tm>

This command disables all external triggers. All relay driver commands are directly output to drivers.

Errors:

If the x or y parameters are not within the specified values, an Invalid Trigger Command error will be generated. This error will turn on the module's error LEDs and generate a VXibus Request True (if Interrupt On Error has been enabled with the I command). Refer to the I command for a complete description of the 73A-308 interrupts and to the QER command for error codes and messages.

**Command:**       VERSION or V

**Syntax:**        VERSION<tm>  
                  V<tm>

**Purpose:**         The Version command returns the current software revision level of the module.

**Description:**   This command returns the revision level of the on-board firmware as an alphanumeric string.

**Example:**       VERSION<tm>

Typical response syntax would be

                  REVISION 1.0<CR><LF>

Command: WAIT or W

Syntax: WAIT x<tm>  
W x<tm>

Purpose: The Wait command holds off execution of commands sent to the 73A-308 to allow relay drivers to be delayed for a specified interval. This delay allows time for relays to be closed or opened before the next command is executed. Once a Wait command is issued, the hold off time will remain valid for all following commands unless overridden by another Wait command or a Reset.

Description: x a number between 0 and 32767 specifying the number of milliseconds.

The x parameter specifies the number of milliseconds the module will wait between the relay output commands C, O, CB, OB, and L. To cancel a command sent after a Wait command is issued, issue a VXibus CLR command to abort all pending commands. To cancel the hold off interval, issue a Wait command setting the hold off to zero, or use Reset.

*NOTE:* The Wait command will only operate when commands are sent. This means that delays programmed between commands will not be stored. When the external trigger is received, the outputs will be latched with no delay. This must be taken into account when using external triggers to latch the driver outputs. Refer to the TS command for more information on external triggers.

Default: x = 0, no wait interval.

Example: WAIT 10<tm> waits for 10 ms between relay output commands.

CLOSE 0<tm> closes relay driver 0

CLOSE 1<tm> with the above Wait command, the 73A-308 will hold off for 10 ms before closing relay driver 1.

Errors: If the x parameter is not specified or is not within the specified values, an Invalid Wait Value error will be generated. This error will turn on the module's Error LED and generate a VXibus Request True (if Interrupt On Error has been enabled with the I command). Refer to the I command for complete description of the 73A-308 interrupts and to the QER command for error codes and messages.

## SYSFAIL, SELF TEST, AND INITIALIZATION

The 73A-308 Module will execute a self test at power-up, or upon direction of a VXIbus hard or soft reset condition, or upon command. A VXIbus hard reset occurs when another device, such as the VXIbus Resource Manager, asserts the backplane line SYSRST\*. A VXIbus soft reset occurs when another device, such as the 73A-308's commander, sets the Reset bit in the 73A-308's Control register.

At power-up, as well as during self test, all module outputs are tri-stated.

During a power-up, or hard or soft reset, the following actions take place:

- 1) The SYSFAIL\* (VME system-failure) line is set active, indicating that the module is executing a self test, and the Fail LED is lit.
- 2) Self test consists of outputting to each byte, binary 0 through 255, and verifying via loopback circuitry that the data is correct.
- 3) If the self test completes successfully, the SYSFAIL\* line is released, and the module enters the VXIbus PASSED state (ready for normal operation). SYSFAIL\* will be released within five seconds in normal operation.

If the self test fails (detects a problem with the VXIbus interface), the SYSFAIL\* line remains active, the Fail LED remains on, and the module enters the VXIbus FAILED state.

If the self test detects a problem with the output drivers, the ERR LED will be lit, a message describing the failure will be queued up to be returned to the module's commander

with the QER command, the SYSFAIL\* line will be released, and the Fail LED will be cleared. In this state the module is still operational.

If the self test completes successfully, the SYSFAIL\* line is released, and the module enters the VXIbus PASSED state (ready for normal operation).

The default condition of the 73A-308 Module after the completion of power-up self test is as follows:

- All relay driver outputs disabled.
- VXIbus external triggers disabled.
- Non-buffered mode.
- Request True interrupts disabled.
- Wait hold off disabled.

A self test can also be run at any time during normal operation by using the S command. The self test consists of internal circuitry tests, and wraparound tests. The results of self test can be read using the query status command QER. If the self test fails, error '1' will be generated, and the module's Fail LED will be lit.

### SYSFAIL\* Operation

SYSFAIL\* becomes active on a software failure, during power-up, hard or soft reset, or if the module loses +5 volt power. When the card cage Resource Manager detects SYSFAIL\* set, it will attempt to inhibit the line. This will cause the 73A-308 Module to deactivate SYSFAIL\* in all cases except when +5 volt power is lost.

## PROGRAMMING EXAMPLES

This section contains example programs which demonstrate how the various programmable features of the 73A-308 are used. The examples are written in BASIC



using an IBM PC or equivalent computer as the system controller.

#### • Definition of BASIC Commands

The programming examples in this manual are written in Microsoft GW BASIC. These examples use the GW BASIC commands described below. If the programming language you are using does not conform exactly to these definitions, use the command in that language that will give the same result.

#### Command      Result

**CALL ENTER (R\$, LENGTH%, ADDRESS%, STATUS%)**

The CALL ENTER statement inputs data into the string R\$ from the IEEE-488 instrument whose decimal primary address is contained in the variable ADDRESS%. Following the input, the variable LENGTH% contains the number of bytes read from the instrument. The variable STATUS% contains the number '0' if the transfer was successful or an '8' if an operating system timeout occurred in the PC. Prior to using the CALL ENTER statement, the string R\$ must be set to a string of spaces whose length is greater than or equal to the maximum number of bytes expected from the 73A-308.

**CALL SEND (ADDRESS%, WRT\$, STATUS%)**

The CALL SEND statement outputs the contents of the string variable WRT\$ to the IEEE-488 instrument whose decimal primary address is contained in the variable ADDRESS%. Following the output of data, the variable STATUS% contains a '0' if the transfer was successful and an '8' if an operating timeout occurred in the PC.

**END** Terminates the program.

#### **FOR/NEXT**

Repeats the instructions between the FOR and NEXT statements for a defined number of iterations.

#### **GOSUB n**

Runs the subroutine beginning with line n. EX: GOSUB 750 - runs the subroutine beginning on line 750. The end of the subroutine is delineated with a RETURN statement. When the subroutine reaches the RETURN statement, execution will resume on the line following the GOSUB command.

#### **GOTO n**

Program branches to line n. EX: GOTO 320 - directs execution to continue at line 320.

#### **IF/THEN**

Sets up a conditional (IF/THEN) statement. Used with other commands, such as PRINT or GOTO, so that IF the stated condition is met, THEN the command following is effective. EX: IF I = 3 THEN GOTO 450 - will continue operation at line 450 when the value of variable I is 3.

#### **REM or '**

All characters following the REM command or a ' are not executed. These are used for documentation and user instructions. EX: REM \*\*CLOSE ISOLATION RELAYS\*\*

#### **RETURN**

Ends a subroutine and returns operation to the line after the last executed GOSUB command.

<CR> Carriage Return character, decimal 13.

<LF> Line Feed character, decimal 10.

## • Programming Examples In BASIC

The following sample BASIC programs show how commands for the 73A-308 might be used. These examples assume that the 73A-308 has logical address 24 and is installed in a VXibus card cage that is controlled via an IEEE-488 interface from an external system controller, such as an IBM PC or equivalent using a Capital Equipment Corp. IEEE-488 interface. The VXibus IEEE-488 interface is assumed to have an IEEE-488 primary address of decimal 0 and to have converted the 73A-308 Module's logical address to an IEEE-488 primary address of decimal 24.

Lines which are indented and not numbered are comments which clarify what the program is doing at those points.

### Example 1

Lines 10 through 40 initialize the PC's IEEE-488 interface card as a system controller with an IEEE-488 address of decimal 0. Line 50 assigns the decimal IEEE-488 address of the 73A-308 to the variable ADDR308%.

```
10  DEF SEG &HC400
      Defines memory location of IBM PC IEEE-488 Interface Module.
20  SEND = 9 : INIT = 0 : ENTER = 21
      Initialize PROM offsets for IBM PC IEEE-488 Interface Module.
30  PC.ADDRESS% = 0 : CONTROL% = 0
      Define IEEE-488 Interface Module's IEEE-488 address, and define it to be a
      controller.
40  CALL INIT (PC.ADDRESS%, CONTROL%)
50  ADDR308% = 24
      Define 73A-308's IEEE-488 address.
60  CONTROL% = 0
      Defines the I/O card as a bus controller.
70  CALL INIT(PC.ADDRESS%,CONTROL%)
80  RDS = SPACES(100)
      Allocate space for the input string variable.
90  TMS = CHR$(10)
      Define the command terminator to be a line feed.

      Reset the card, and then read its default message.
100 CLS
      Clear the screen.
105 STEPNUM = 1
```

Initialize the step number variable.

```

110 WRT$ = "R" + TMS
      Reset the card.
120 CALL SEND(ADDR308%,WRT$,STATUS%)
      Output the reset command.
130 CALL ENTER(RD$,LENGTH%,ADDR308%,STATUS%)
      Read the default message. The card should respond with "READY<CR><LF>".
140 PRINT "DEFAULT MESSAGE -> " + RD$
      Print the default message.
150 WRT$ = "S;QER" + TMS
      Issue a self test command to the card (S command), and read the result back using
      the query (QER) command. A semi-colon is used as the command terminator for
      the S command, and a line-feed as the terminator for the QER command.
160 CALL SEND(ADDR308%,WRT$,STATUS%)
      Output the command.
170 CALL ENTER(RD$,LENGTH%,ADDR308%,STATUS%)
      Read and print the results. The card should respond with
      "NO ERRORS<CR><LF>".
180 PRINT "SELF TEST RESULT -> " + RD$
190 WRT$ = "C0;C8;C6;E" + TMS
      Close and enable output lines 0, 8, and 6. The commands being issued do the following:
      C0, C8, C6 - close relay drivers 0, 8, and 6.
      E - enables the outputs.
      A semicolon between commands represents a terminator or line feed.
200 CALL SEND(ADDR308%,WRT$,STATUS%)
      Output the command. The R0, R8, and R6 LEDs and the ENB LED on the front
      panel should be lit.
210 WRT$ = "Q8" + TMS
      Read back the status of relay driver 8 using the Q command.
220 CALL SEND(ADDR308%,WRT$,STATUS%)
      Output the command.
230 CALL ENTER(RD$,LENGTH%,ADDR308%,STATUS%)
      Read and print the results.
240 PRINT "THE RELAY DRIVER STATUS IS -> " + RD$
      The card should respond with "1<CR><LF>" as the data. This means that the relay
      driver is active.
250 WRT$ = "O0;O8;O6" + TMS
      Open relay drivers 0, 8, and 6.
260 CALL SEND(ADDR308%,WRT$,STATUS%)
      Output the command.
270 WRT$ = "QRB" + TMS
      Read back the status of all outputs using the QRB command. The data is returned
      in 20 hex bytes.
280 CALL SEND(ADDR308%,WRT$,STATUS%)
290 CALL ENTER(RD$,LENGTH%,ADDR308%,STATUS%)
300 PRINT "THE DATA IS -> " + RD$
      The card should respond with "00000000000000000000<CR><LF>" as the data.

```

## Example 2

This is a more advanced program for the experienced user which demonstrates the use of the Close Bank, Open Bank, Load, Wait, and External Trigger commands.

Lines 10 through 90 are required to initialize the IEEE-488 Bus Interface Module.

```
10 DEF SEG = &HC400
    Defines memory location for PCX I/O card.
20 SEND = 9 : INIT = 0 : ENTER = 21
30 PC.ADDRESS% = 0
    defines I/O card address.
40 ADDR308% = 24
    Defines 73A-308 logical address.
50 CONTROL% = 0
    Defines I/O card as a bus controller.
60 TMS$ = CHR$(10)
    Define line feed terminator.
70 CALL INIT(PC.ADDRESS%,CONTROL%)
80 IF STATUS% <> 0 THEN PRINT "*** 488 FATAL ERROR ***": STOP
90 RD$ = SPACES$(100)
    Allocate space for the input string variable.
```

Reset the card, and then read its default message. The LEFT\$ function is used to suppress the carriage return / line feed characters from the response data for printing to the screen. The default message response is "READY".

```
100 CLS
    Clear the screen.
110 WRT$ = "R" + TMS$
    Reset the card.
120 CALL SEND(ADDR308%,WRT$,STATUS%)
130 CALL ENTER(RD$,LENGTH%,ADDR308%,STATUS%)
140 PRINT ("DEFAULT MESSAGE -> " + LEFT$(RD$,LENGTH%))
```

The following lines show how the Load (L) command works.

```
150 WRT$ = "L000000000018A000000A;E" + TMS$
160 GOSUB 1500
    Prints the command string and the read-back, or response data. The above Load
    command activates relay drivers 1, 3, 29, 31, 35, and 36. The 'E' enables outputs.
```

The following lines show how the CB, OB, and Wait commands operate.

```
170 WRT$ = "WAIT 200;CB0;CB1;OB0" + TMS$
180 GOSUB 1500
    The Wait 200 programs the 73A-308 for a 200 ms delay between output commands. Close
    bank 0, relay drivers 0 through 7 are active, and wait for 200 ms, then closes bank 1,
    relay drivers 8 through 15 are activated, and waits for 200 ms. Then bank 1 opens, and
    relay drivers 0 through 7 are deactivated, and the 73A-308 holds off other commands for
```

200 ms. The Enable command was sent with the previous Load command so the outputs are already enabled.

*NOTE:* The IEEE timeout must be greater than the maximum total Wait value. In this case, larger than 600 ms (adding all delays together).

The following lines show how the TS command operates.

```
190 WRT$ = "R" + TMS
```

```
200 GOSUB 1500
```

Reset the card.

```
210 WRT$ = "TS G,0"
```

```
220 GOSUB 1500
```

Sets up the 73A-308 to update all outputs only when an IEEE Group Execute Trigger is received, and also to output a VXibus trigger on TTL trigger line 0 when a T or TRIGGER command is issued.

```
230 WRT$ = "C0;C1;C2;"
```

The Close commands are stored until an IEEE-488 Group Execute Trigger is received. When the trigger is received, relay drivers 0, 1, and 2 will be activated. The above E (Enable) command enabled all drivers.

```
240 GOSUB 1500
```

```
250 WRT$ = "LOAD FFFFFFFFFFFFFFFFFFFFFF;"
```

```
260 GOSUB 1500
```

The load command will activate all relay drivers when an IEEE-488 Group Execute Trigger is received.

```
270 WRT$ = "QRB;"
```

```
280 GOSUB 1500
```

This Query command will return 20 hex bytes that represent the relay drivers. the response would be FFFFFFFFFFFFFFFFFFFFFF if an IEEE-488 Group Execute Trigger had been received, and would be "00000000000000000000<CR><LF>" if no trigger had been received.

```
1500 PRINT "cmd = " + WRT$
```

```
1510 CALL SEND(ADDR308%,WRT$,STATUS%)
```

```
1520 CALL ENTER(RD$,LENGTH%,ADDR308%,STATUS%)
```

```
1530 PRINT "73A-308 RESPONSE = " + LEFT$(RD$,LENGTH%)
```

```
1540 RETURN
```

## SYNCHRONIZING MULTIPLE INSTRUMENTATION MODULES

When designing a test procedure, it is important to take into account the problems that can arise if the individual instrument modules are not properly synchronized. For example, if a relay on one module switches a signal to a voltmeter on another module, and the voltmeter reads the value before the relay has settled, an improper reading will result.

There are two primary methods of implementing proper synchronization:

- 1) One is to send data to one or more modules as quickly as possible and then check to see if all on-module operations are complete before performing the secondary operation (for example, reading the voltage).
- 2) The second method is to have the module hold off the data coming from the controller until the on-module operation is complete. In this case, the voltmeter can be read immediately after the first module is programmed.

The particular application generally determines the method used. The first method results in faster throughput, but requires that some kind of polling sequence take place to assure that on-module operations are complete. The second method is easier to implement and insures that no module will be programmed before operations on a previously addressed module are complete. However, this method may cause one module to hold up data transfer during an interval when other modules could be programmed.

The 73A-308 allows you to use either method. The first method can be initiated by sending the BE (Buffer Enable) command, which allows data collection and

data processing to occur in parallel, thus allowing optimal data transfer rates. The VXI fast handshake protocol is used during this time. To be sure that the 73A-308 operations are complete, send any command that will return a response (V or QER commands) and then read the response. The response will not be returned until all commands in the 73A-308's input buffer have been executed.

The second method uses the default setting on the 73A-308, the nonbuffered mode. For C, CB, O, or OB commands, this means that the output will be programmed to the specified value upon the module's acceptance of the second byte after the last digit of a numeric value. If a <CR><LF> is used to terminate the command, this corresponds to the <LF>. If a semicolon is used for termination, either a space following the semicolon or two semicolons without a space between them can be sent. For all other commands, such as the L command, operations are guaranteed to be complete before the first character of the next command will be accepted.

When using synchronized nonbuffered mode, it is important that the slot 0 module maintain byte-to-byte synchronization between modules. The 73A-155 RM/488 Interface Module will maintain this synchronization.

## APPENDIX A - VXIbus OPERATION

The 73A-308 Module is a C size single slot VXIbus Message-Based Word Serial instrument. It uses the A16, D16 VME interface available on the backplane P1 connector and does not require any A24 or A32 address space. The module is a D16 interrupter.

The 73A-308 Module is neither a VXIbus commander or VMEbus master, and therefore it does not have a VXIbus Signal register. The 73A-308 is a VXIbus message based servant.

The module supports the Normal Transfer Mode of the VXIbus, using the Write Ready, Ready Ready, Data In Ready (DIR), and Data Out Ready (DOR) bits of the module's Response register.

A Normal Transfer Mode read of the 73A-308 Module proceeds as follows:

1. The commander reads the 73A-308's Response register and checks if the Write Ready and DOR bits are true. IF they are, the commander proceeds to the next step. If not, the commander continues to poll these bits until they become true.
2. The commander writes the Byte Request command (0DEFFh) to the 73A-308's Data Low register.
3. The commander reads the 73A-308's Response register and checks if the Read Ready and DOR bits are true. If they are, the commander proceeds to the next step. If not, the commander continues to poll these bits until they become true.
4. The commander reads the 73A-308's Data Low register.

A Normal Transfer Mode Write to the 73A-308 Module proceeds as follows:

1. The commander reads the 73A-308's Response register and checks if the Write Ready and DIR bits are true. If they are, the commander proceeds to the next step. If not, the commander continues to poll the Write Ready and DIR bits until they are true.
2. The commander writes the Byte Available command which contains the data (0BCXX or 0BDXX, depending on the End bit) to the 73A-308's Data Low register.

The 73A-308 Module also supports the Fast Handshake Mode during readback. In this mode, the module is capable of transferring data at optimal backplane speed without the need of the commander's testing any of the handshake bits. The 73A-308 Module asserts BERR\* to switch from Fast Handshake Mode to Normal Transfer Mode, per VXI Specification. The 73A-308's Read Ready, Write Ready, DIR and DOR bits react properly, in case the commander does not support the Fast Handshake Mode.

A Fast Handshake Transfer Mode Read of the 73A-308 Module proceeds as follows:

1. The commander writes the Byte Request command (0DEFFh) to the 73A-308's Data Low register.
2. The commander reads the 73A-308's Data Low register.

The 73A-308 Module has no registers beyond those defined for VXIbus message based devices. All communications with the module are through the Data Low register, the Response register or the VXIbus interrupt cycle. Any attempt by another

module to read or write to any undefined location of the 73A-308's address space may cause incorrect operation of the module.

As with all VXibus devices, the 73A-308 module has registers located within a 64 byte block in the A16 address space.

The base address of the 73A-308 device's registers is determined by the device's unique logical address and can be calculated as follows:

$$\text{Base Address} = V * 40H + C000H$$

where V is the device's logical address as set by the Logical Address switches.

#### 73A-308 Configuration Registers.

Below is a list of the 73A-308 Configuration registers with a complete description of each. In this list, RO = Read Only, WO = Write Only, R = Read, and W = Write. The offset is relative to the module's base address:

### REGISTER DEFINITIONS

<u>Register</u>	<u>Address</u>	<u>Type</u>	<u>Value (Bits 15-0)</u>
ID Register	0000H	RO	1011 1111 1111 1100 (BFFCh)
Device Type	0002H	RO	See Device Type definition below
Status	0004H	R	Defined by state of interface
Control	0004H	W	Defined by state of interface
Offset	0006H	WO	Not used
Protocol	0008H	RO	1111 0111 1111 1111 (F7FFh)
Response	000AH	RO	Defined by state of the interface
Data High	000CH		Not used
Data Low	000EH	W	See Data Low definition below
Data Low	000EH	R	See Data Low definition below



**BIT DEFINITIONS**

<u>Register</u>	<u>Bit Location</u>	<u>Bit Usage</u>	<u>73A-308 Value</u>	<u>73A-308 Usage</u>
ID	15-14	Device Class	10	Message Based
	13-12	Address Space	11	A16 only
	11-0	Manufact. ID	1111 1111 1100	Colorado Data Systems
Device Type	15-0	Device Type	1111 1110 1100 1011	Ones comp. of 308
Status	15	A24/32 Active	x	Not used
	14	MODID*	1 0	MODID line not active MODID line active
	13-4	Device dependent	xx xxxx xxxx	Not used
	3	Ready	0 or 1	Per VXI Spec.
	2	Passed	1 0	Passed VXI Interface failure
	1-0	Device dependent	xx	Not used
	Control	15	A24/32 Enable	x
14-2		Device dependent	xx xxxx xxxx xx	Not used
1		SYSFAIL Inhibit	1 0	Disables module from driving Sysfail Enables module to drive Sysfail
0		Reset	1 0	Reset Not reset
Protocol		15	CMDR*	1
	14	Signal Reg.*	1	No Signal Reg.
	13	Master*	1	Slave only
	12	Interrupter	1	Interrupter
	11	FHS*	0	Fast Handshake capability
	10	Shared Memory*	1	No Shared Memory capability
	9-4	Reserved	11 1111	Not used
	3-0	Device dependent	1111	Not used
Response	15	Defined value of 0	0	Per VXI
	14	Reserved	1	Per VXI
	13	DOR	1 or 0	1 indicates that instrument data may be read at this time.
	12	DIR	1 or 0	1 indicates that instrument data may be sent to this module.
	11	ERR*	1 0	No VXI error has occurred VXI error has occurred.

**BIT DEFINITIONS**

<u>Register</u>	<u>Bit Location</u>	<u>Bit Usage</u>	<u>73A-308 Value</u>	<u>73A-308 Usage</u>
Response	10	Read Ready	1 or 0	Indicates that data may be read from this module at this time. Set by the instrument following a "Byte Request" or any other VXI command requiring readback. Cleared on reset or when no data is left to send. Indicates that VXI commands or instrument data may be written at this time. Indicates that this module is capable of supporting fast handshake (not requiring handshake) at this point in time. Follows the state of the Clear Lock and Set Lock VXIbus commands. Not used
	9	Write Ready	1 or 0	
	8	FHS Active*	1	
	7	Locked*	1 or 0	
	6-0	Device dependant	xxx xxxx	

Data High - not implemented.

Data Low (read/write)

### Word Serial Commands

A write to the Data Low register causes this module to execute some action based on the data written. This section describes the device specific Word Serial commands this module responds to and the results of these commands.

Read Protocol Command:

```

15 14 13 12 11 10 9 8 7 6 5 4 3 2 1 0
1 1 0 1 1 1 1 1 1 1 1 1 1 1 1

```

If the Data Low register is read after this command, the contents are as follows:

### BIT DEFINITIONS

<u>Register</u>	<u>Bit Location</u>	<u>Bit Usage</u>	<u>73A-308 Value</u>	<u>73A-308 Usage</u>
-----------------	---------------------	------------------	----------------------	----------------------

Read Protocol	15	VXI Rev.	1	VXI Revision 1.3
	14-11	Device Dependant	1111	not used
	10	Reserved	1	Reserved
	9	RG*	1	response generation not supported
	8	EG*	0	event generation supported
	7	Zero	0	must be 0, per VXI specification.
	6	PI*	1	programmable interrupts not supported
	5	PH*	1	programmable interrupt handlers not supported
	4	TRG*	0	Word Serial Trigger command supported
	3	I4*	1	488.2 protocol not supported
	2	I*	0	VXIbus Instrument Protocol supported
	1	ELW*	1	Extended Long Word protocol not supported
	0	LW*	1	Long Word protocol not supported
Read STB	15-8	Upper byte	1111 1111	not used
	7	not used	0	not used
	6	RQS	1 or 0	set when a request true interrupt has been generated. Cleared upon the execution of this command.
	5-0	not used	0	not used
Async Mode Control	15-12	Status	1111 0111	command successful command unsuccessful. this occurs if bits 0 or 1 of this command are 1 indicating that a request is being made to have responses and/or events sent as signals. This module supports interrupts rather than signals.
	11-4	not used	1111 1111	not used
	3	Resp En*	0 or 1	if bits 15-12 are 1111, echos bit 3 of the command
	2	Event En*	0 or 1	if bits 15-12 are 1111, echos bit 2 of the command
	1	Resp Mode	0	interrupts are supported
	0	Event Mode	0	interrupts are supported

Register      Bit Location    Bit Usage                      73A-308 Value                      73A-308 Usage

Control

Response	15-12		1111	command passed
	11-7	not used	11111	not used
	6-0		1111111	no responses supported

## APPENDIX B - FRONT PANEL OUTPUT CONNECTIONS

Output pin assignments for P4 as a function of the commands.

Bank	Digit	BCD Bit	Relay Driver Control Line	Output Pin	Clamp
0	R <sub>0</sub>	1	0	36	W0 A - B* P4-50
		2	1	3	
		4	2	19	
		8	3	2	
	R <sub>1</sub>	1	4	35	
		2	5	1	
		4	6	34	
		8	7	18	
1	R <sub>2</sub>	1	8	40	W1 A - B* P4-50
		2	9	24	
		4	10	7	
		8	11	23	
	R <sub>3</sub>	1	12	39	
		2	13	6	
		4	14	38	
		8	15	22	
2	R <sub>4</sub>	1	16	43	W2 A - B* P4 - 17
		2	17	27	
		4	18	10	
		8	19	26	
	R <sub>5</sub>	1	20	42	
		2	21	9	
		4	22	41	
		8	23	25	
	R <sub>6</sub>	1	24	46	

Bank	Digit	BCD Bit	Relay Driver Control Line	Output Pin	Clamp		
		2	25	30			
3		4	26	13	W3 B - C* P4 - 17		
		8	27	29			
		R <sub>7</sub>	1	28		45	
	2	29	12				
	4	30	44				
	8	31	28				
	4	R <sub>8</sub>	1	32		49	W4 B - C* P4 - 17
			2	33		33	
4			34	16			
8			35	32			
R <sub>9</sub>		1	36	48			
		2	37	15			
		4	38	47			
		8	39	31			
Ground Returns: 4, 5, 8, 11, 14, 20, 21, 37							

\* Factory setting for Clamp line.

Output pin assignments for P5 as a function of the commands.

Bank	Digit	BCD Bit	Relay Driver Control Line	Output Pin	Clamp
5	R <sub>10</sub>	1	40	36	W5 A - B* P5-50
		2	41	3	
		4	42	19	
		8	43	2	
	R <sub>11</sub>	1	44	35	
		2	45	1	
		4	46	34	
		8	47	18	
6	R <sub>12</sub>	1	48	40	W6 A - B* P5-50
		2	49	24	
		4	50	7	
		8	51	23	
	R <sub>13</sub>	1	52	39	
		2	53	6	
		4	54	38	
		8	55	22	
7	R <sub>14</sub>	1	56	43	W7 A - B* P5 - 17
		2	57	27	
		4	58	10	
		8	59	26	
	R <sub>15</sub>	1	60	42	
		2	61	9	
		4	62	41	
		8	63	25	
	R <sub>16</sub>	1	64	46	

Bank	Digit	BCD Bit	Relay Driver Control Line	Output Pin	Clamp
8		2	65	30	W8 B - C* P5 - 17
		4	66	13	
		8	67	29	
		1	68	45	
	R <sub>17</sub>	2	69	12	
		4	70	44	
		8	71	28	
		1	72	49	
9	R <sub>18</sub>	2	73	33	W9 B - C* P5 - 17
		4	74	16	
		8	75	32	
		1	76	48	
	R <sub>19</sub>	2	77	15	
		4	78	47	
		8	79	31	
		Ground Returns: 4, 5, 8, 11, 14, 20, 21, 37			

\* Factory setting for Clamp line.



## APPENDIX C - VXibus GLOSSARY

Certain terms used in this manual have very specific meanings in the context of a VXibus System. A list of these terms is presented below.

### Commander

A VXibus device that has bus master capability and has VXibus servants under it in the system hierarchy. A commander may be a servant as well.

### Fast Handshake

Compared to the Normal Transfer Mode of the VXibus, the Fast Handshake Transfer Mode reduces the number of VMEbus data transfer cycles by 50%. On receipt of a request for data, a fast handshake module is able to return data in less than 20  $\mu$ s, so that the VXibus fast handshake protocol can be used by the module's commander. Using fast handshake protocol, data can be written and read without checking the ready bits in the module's Response register.

### Hard Reset

This is the state of the module when the SYSRESET\* line is true. While in this state, the module is inactive and its Status and Control registers are cleared. The SYSFAIL\* line is driven low, and the Failed LED is lit. In the case of a CDS 73A-IBX card cage, for example, a module hard reset occurs when the card cage is powered-up or the Reset switch on the front panel of the 73A-155 Resource Manager/IEEE-488 Interface Module is depressed.

### Interrupt Handler

The module in the VXibus system that generates the hardware interrupt acknowledge for a particular VME interrupt level. The software interrupt handler may or may not be on the same module as the hardware interrupt handler. In the case of CDS instrument modules, both the hardware and software interrupt handlers reside on the commander module of a given servant module.

### Logical Address

A unique eight bit number which identifies each VXibus device in a system. It defines the device's A16 register addresses, and indicates the device's commander/servant relationship.

### Reset Bit

Bit 0 in the Control register of the module. When set to a one (1) by the module's commander or resource manager, the device is forced into a reset state.

### Resource Manager

A message based commander located at logical address 0, which provides configuration management services, including self test, address map configuration, commander/servant mapping, and diagnostic management. In CDS systems, the Resource Manager function is co-located with the VMEbus controller, the slot 0 timing functions, and the system controller interface.

### Servant

A VXIbus device that may or may not have bus master capability, that is under control of a commander in the VXIbus system hierarchy. A servant may also be a commander.

### Soft Reset

This state is entered when the reset bit in the module's Control Register is set to one (1) by the module's commander. While in this state a device is inactive, interrupts which are pending are unasserted, all pending bus requests are unasserted, and the onboard processor is halted. The device's VMEbus slave interface is active in this state; however, the device is incapable of responding to any commands other than RESET and SYSFAIL INHIBIT. In the case of a CDS 73A-IBX card cage, for example, a module soft reset occurs when the card cage's 73A-155 Resource Manager/IEEE 488 Interface Module receives a STOP command over the IEEE-488 bus that is addressed to the 73A-308.

### SYSFAIL INHIBIT

Bit 1 in the Control register of the module. When set to a one (1) by the VXIbus Resource Manager, the device is disabled from driving the SYSFAIL\* line. CDS modules are designed so that the Sysfail Inhibit bit will work under all conditions except when the +5V power is lost.

### VXI Commands

These are commands passed from a commander to a servant within the VXIbus environment. A command may or may not be prompted by an external event. For example, an IEEE-488 GROUP EXECUTE TRIGGER will generate a trigger command to all addressed devices. However, a BEGIN NORMAL OPERATIONS command is generated

by the VXIbus Resource Manager and has no external source.

### VXI Events

Events are passed from a servant to a commander. They may be generated by the servant either in response to a command (for example, Unrecognized Command event) or due to a condition detected in the module (internal error).

### VXI Message Based Instrument

An intelligent instrument that implements the defined VXIbus registers and, at a minimum, the word serial protocol. All CDS instruments are message based.

### VXI Word Serial Protocol

The simplest required communication protocol supported by Message Based devices in a VXIbus system. It utilizes the A16 communications registers to transfer data using a simple polling handshake method. All CDS instruments implement the word serial protocol.

### 488-VXIbus Interface

An IEEE-488 to VXIbus Interface Device is a message based device which provides communication between the IEEE-488 bus and VXIbus instruments.

## APPENDIX D - TYPICAL DRIVER CIRCUIT

### CAUTION:

To avoid damage to the 73A-308 from inductive voltage spikes created when relays are turned off, the "Supply Input" must be connected to the positive terminal of the external supply that powers the relay coils.

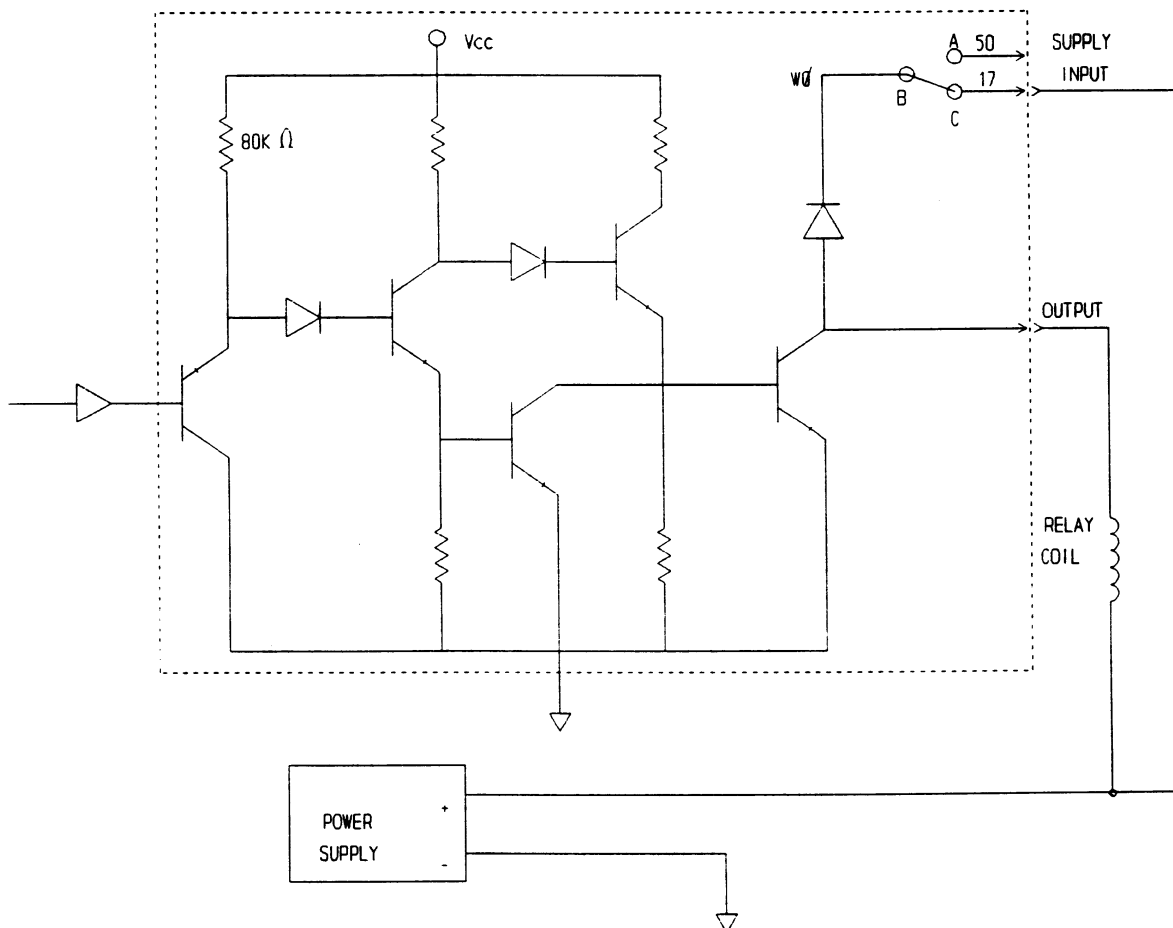

# Appendix E

## User Service

This appendix contains service-related information that covers the following topics:

- Preventive maintenance
- User-replaceable Parts

### Preventive Maintenance

You should perform inspection and cleaning as preventive maintenance. Preventive maintenance, when done regularly, may prevent malfunction and enhance reliability. inspect and clean the module as often as conditions require by following these steps:

1. Turn off power and remove the module from the VXIbus mainframe.
2. Remove loose dust on the outside of the instrument with a lint-free cloth.
3. Remove any remaining dirt with lint-free cloth dampened in a general purpose detergent-and-water solution. Do not use abrasive cleaners.

### User-Replaceable Parts

Replacement parts are available through your local Tektronix field office or representative.

Changes to Tektronix instruments are sometimes made to accommodate improved components as they become available. Therefore, when ordering parts, it is important to include the following information in your order.

- Part number
- Instrument type or model number
- Instrument serial number
- Instrument modification number, if applicable.

**User-Replaceable Parts**

<b>Part Description</b>	<b>Part Number</b>
User Manual	070-9118-02
Label, Tek CDS	950-0616-00
Label, VXI	950-0617-00
Fuse, Micro 4 Amp 125 V Fast	159-0374-00
Collar Screw, Metric 2.5 × 11 Slotted	950-0952-00
Shield, Front	950-1338-00
Screw, Phillips Metric 2.5 × 4 FLHD SS	211-0867-00

# Appendix F – Performance Verification Procedure

The performance verification procedure for the 73A-308 Relay and High Voltage Driver Module verify that the module is operating within specification.

## Conventions Used In This Procedure

All control of the 73A-308 Module will be accomplished through a VXI Slot 0 device. ASCII characters will form the commands sent to control the module and ASCII characters will be read from the module.

Throughout this document writes to the 73A-308 Module will be shown as:

Send “QERlf”

where QERlf is the command (Query the ERror) terminated with a linefeed character (lf). Commands will be sent exactly as shown.

Reads from the module are shown as:

Read “NO ERRORS<sub>crlf</sub>”

where NO ERRORS<sub>crlf</sub> is the ASCII string returned from the 73A-308 Module, terminated with a carriage return and linefeed (crlf). The ASCII string returned from the module will be exactly as shown.

Unless noted, all commands are sent to the 73A-308 Module and all ASCII strings read are read from the 73A-308 Module.

Two characters are used throughout the communication sequences: “cr” is the carriage return character (character 13) and “lf” is the line feed character (character 10). These characters are the terminating characters for communication. They are shown throughout this document in the font shown here. Most reads from the 73A-308 Module are terminated with both characters and are shown as “crlf”. Writes to the module require only a “lf”, but both characters may be used.

An ASCII upper case letter “O” will be shown as “O” whereas a ASCII zero will be shown as “0”.

## Equipment Required

Table 1–1 lists the equipment required for the performance and verification procedure.

**Table 1–1: Equipment Required**

Required tools and equipment	Part number
VXI Mainframe (such as the Tektronix VX1410)	n/a
VXI Slot 0 with resource Manager (Tektronix VX4521) and appropriate cables and interface cards.	n/a

**Table 1-1: Equipment Required (Cont.)**

Required tools and equipment	Part number
Digital Multi Meter (DMM)	standard lab equipment
+50 V POWER SUPPLY capable of 300ma	standard lab equipment
+5 V Power supply capable of 2.5A	standard lab equipment
15 $\Omega$ 3 Watt 5% Resistor, requires 8 resistors	n/a
165 $\Omega$ 3 Watt 5% Resistor	n/a
Talker/Listener (Send/Read) program with the capability to send out word	n/a
Serial commands	n/a

## Performance Verification Procedure

### Default Conditions

1. Shut the VXI system down, and then power up the VXI system and wait 10 seconds.
2. Only the green PWR LED will be lit, if this is not true, repeat step 1.
3. Send a “QERlf” (Query ERrors) to the 73A-308.
4. Read “NO ERRORScrlf”
5. Send “QENlf” (Query Enable/disable status) to the 73A-308.
6. Read “0crlf”
7. Send “QRBlf” (Query Read Back status) to the 73A-308.
8. Read “00000000000000000000crlf”
9. Send “QTGlf” (Query TriGger status) to the 73A-308.
10. Read “0crlf”

### LED Test

1. Remove power from the VXI system, then reapply power. The FAIL LED will be briefly lit in red during power up.
2. When the following command is sent to the 73A-308, the MSG LED will flash for about a half second.
  - a. Send “Rcrlf” (Reset)

- b. The PWR LED will be the only LED lit after the MSG LED goes out.
- 3. Send “AcrLf” (invalid command) to the 73A-308.
  - a. The ERR LED and PWR LED will be lit. All other LEDs will be out.
  - b. Send “RcrLf” (Reset) to the 73A-308
- 4. Send “EcrLf” (Enable outputs) to the 73A-308.
  - a. The ENB LED and PWR LED will be lit. All other LEDs will be out.
- 5. Send “D;CB0;CB1crLf” (Disable outputs, Close Banks 0 and 1) to the 73A-308.
  - a. The R0, R1, R2, R3, R4, R5, R6, R7, R8, R9, and PWR LEDs will all be lit. All other LEDs will be out.
  - b. Send “RcrLf” (Reset) to the 73A-308.
- 6. Press the MSD SEL button on the 73A-308 face plate.
  - a. The D1 LED will come on
  - b. Press the MSD SEL button again
  - c. The D2 and PWR LEDs will be lit, all other LEDs will be out
  - d. Press the MSD SEL button repeatedly and watch the D1, D2, and D4 LEDs do a binary count until all are lit, and then all LEDs will go out when the count reaches zero.

Selftest and Power Default Output State

- 1. Send “Sif” (Selfttest) to the 73A-308.
- 2. Read “READY<sub>crLf</sub>”.
  - a. If the 73A-308 returns another ASCII string, the built in self test failed and the string indicates what the failure was.
- 3. Send: “QRBif” (Query Read Back status) to the 73A-308.
- 4. Read: “00000000000000000000<sub>crLf</sub>”



## Collector Current Test

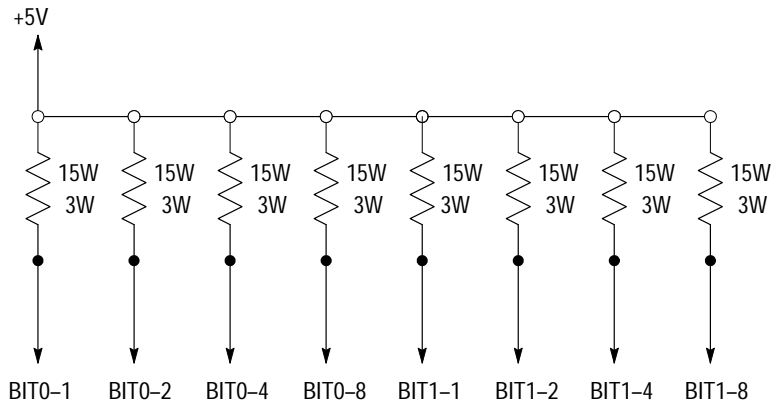

Figure 1-1: Resistor matrix

Table 1-2: Bit number versus pin number

Bit number	Connector P4 pin number
0-1	36
0-2	3
0-4	19
0-8	2
1-1	35
1-2	1
1-4	34
1-8	18

### Bank 0

1. Using the power supply listed in Table 1-1, connect a 15  $\Omega$ , 3 W resistor from +5V of the power supply, to each of the pins as shown in Figure 1-1, and in Table 1-2.
2. Connect the +5 V to P4 pin 50.
3. Connect the ground from the power supply to P4 pin-4 and pin-5.
4. Send “Dir” (Disable all outputs) to the 73A-308.
5. Send “CB0ir” (Close Bank 0) to the 73A-308.

6. Using a DMM measure the voltage at each pin of P4 as listed in Table 1–2. The voltage at each pin will be the same as the +5V source.
7. Send “Eif” (Enable all outputs) to the 73A-308.
8. Measure the voltage at each P4 pin shown in Table 1–2. The voltage at each pin will be less than +500 mV.
9. Send “QRBif”
10. Read “0000000000000000FF<sub>crif</sub>”
11. Send “O0if” (Open 0) to the 73A-308.
12. Use a DMM and measure the voltage at BIT 0–1 (refer to Table 1–2). The voltage will be the same as the +5 V source.
13. The voltage at the remaining 7 pins shown in Table 1–2 will be less than +500 mV.
14. Send “QRBif”
15. Read “0000000000000000FE<sub>crif</sub>”
16. Send “O1if” (Open 1) to the 73A-308.
17. Use a DMM and measure the voltage at BITS 0–1 and 0–2 (refer to Table 1–2). The voltage on both pins will be the same as the +5 V source.
18. The voltage at the remaining 5 pins shown in Table 1–2 will be less than +500 mV.
19. Send “QRBif”
20. Read “0000000000000000FC<sub>crif</sub>”
21. Send “O2if” (Open 2) to the 73A-308.
22. Use a DMM and measure the voltage at BITS 0–1, 0–2, and 0–4 (refer to Table 1–2). The voltage on these pins will be the same as the +5 V source.
23. The voltage at the remaining 4 pins shown in Table 1–2 will be less than +500 mV.
24. Send “QRBif”
25. Read “0000000000000000F8<sub>crif</sub>”
26. Send “O3if” (Open 3) to the 73A-308.
27. Use a DMM and measure the voltage at BITS 0–1, 0–2, 0–4, and 0–8 (refer to Table 1–2). The voltage on these pins will be the same as the +5 V source.

28. The voltage at the remaining 4 pins shown in Table 1–2 will be less than +500 mV.
29. Send “QRB<sub>if</sub>”
30. Read “0000000000000000F0<sub>crIf</sub>”
31. Send “O4<sub>if</sub>” (Open 4) to the 73A-308.
32. Use a DMM and measure the voltage at BITS 0–1, 0–2, 0–4, 0–8, and 1–1 (refer to TABLE 4–1). The voltage on these pins will be the same as the +5 V source.
33. The voltage at the remaining 3 pins shown in Table 1–2 will be less than +500 mV.
34. Send “QRB<sub>if</sub>”
35. Read “0000000000000000E0<sub>crIf</sub>”
36. Send “O5<sub>if</sub>” (Open 5) to the 73A-308.
37. Use a DMM and measure the voltage at BITS 0–1, 0–2, 0–4, 0–8, 1–1, and 1–2 (refer to Table 1–2). The voltage on these pins will be the same as the +5 V source.
38. The voltage at the remaining 2 pins shown in Table 1–2 will be less than +500 mV.
39. Send “QRB<sub>if</sub>”
40. Read “0000000000000000C0<sub>crIf</sub>”
41. Send “O6<sub>if</sub>” (Open 6) to the 73A-308.
42. Use a DMM and measure the voltage at BITS 0–1, 0–2, 0–4, 0–8, 1–1, 1–2, and 1–4 (refer to Table 1–2). The voltage on these pins will be the same as the +5 V source.
43. The voltage at the remaining pin shown in Table 1–2 will be less than +500 mV.
44. Send “QRB<sub>if</sub>”
45. Read “000000000000000080<sub>crIf</sub>”
46. Send “O7<sub>if</sub>” (Open 7) to the 73A-308.
47. Use a DMM and measure the voltage at all eight BITS (refer to Table 1–2). The voltage on these pins will be the same as the +5 V source.
48. Send “QRB<sub>if</sub>”
  - a. Read “000000000000000000<sub>crIf</sub>”

## **Banks 1 thru 9 – Perform the following for all the remaining groups:**

Connect the 15  $\Omega$  resistors to the output pins of the next Bank to be checked and insure that the positive (+) side of the +5 V is connected to the input pin for that bank: P4 pin-50 for banks 0, 1 and 2, P4 pin-17 for banks 3, and 4, or P5 pin-50 for banks 5, 6 and 7, P5 pin-17 for banks 8, and 9.

Perform the test requirements from number 4 thru 48 of the Bank 0 Test, substituting the appropriate group and relay numbers in the CB and O commands. The voltages read must meet the requirements of the Bank 0 Test.

### **High Voltage Test**

1. Send “R;E;Dir” (Reset, enable and then disable all outputs) to the 73A-308.
2. Connect one end of a 165  $\Omega$ , 15 W resistor to a +50V power supply and also connect the +50 V to P4 pin-50.

Connect the other end of the resistor to P4 pin-36, Relay Driver 0. Connect the ground from the +50V power supply to P4 pin-4 and 5.

The +50 V power supply must be capable of producing 300 mA.

3. Send “C0lf” (Close Relay Driver 0) to the 73A-308.
4. Measure the voltage at P4 pin-36. The voltage will be the same as the +50 V source.
5. Send “Elf” (Enable all outputs) to the 73A-308.
6. Measure the voltage at the P4 pin-36. The voltage will be less than +500 mV.
7. Send “R;E;Dir” (Reset, enable and then disable all outputs) to the 73A-308.
8. Connect the 165  $\Omega$ , 15 W resistor from the +50 V power supply to P4 pin-40, Relay Driver 8.
9. Send “C8lf” (Close Relay Driver 8) to the 73A-308.
10. Measure the voltage at P4 pin-40. The voltage will be the same as the +50V source.
11. Send “Elf” (Enable all outputs) to the 73A-308.
12. Measure the voltage at the P4 pin-40. The voltage will be less than +500 mV.
13. Send “R;E;Dir” (Reset, enable and then disable all outputs) to the 73A-308.
14. Connect the 165  $\Omega$ , 15 W resistor from the +50V to P4 pin-43, Relay Driver 16.

15. Send “C16lr” (Close Relay Driver 16) to the 73A-308.
16. Measure the voltage at P4 pin-43. The voltage will be the same as the +50 V source.
17. Send “Elr” (Enable all outputs) to the 73A-308.
18. Measure the voltage at P4 pin-43. The voltage will be less than +500 mV.
19. Send “R;E;Dir” (Reset, enable and then disable all outputs) to the 73A-308.
20. Connect the 165  $\Omega$ , 15 W resistor from the +50V, to P4 pin-46, Relay Driver 24.
21. Send “C24lr” (Close Relay Driver 24) to the 73A-308.
22. Measure the voltage at P4 pin-46. The voltage will be the same as the +50 V source.
23. Send “Elr” (Enable all outputs) to the 73A-308.
24. Measure the voltage at P4 pin-46. The voltage will be less than +500 mV.
25. Send “R;E;Dir” (Reset, enable and then disable all outputs) to the 73A-308.
26. Connect the 165  $\Omega$ , 15 W resistor from +50 V to P4 pin-49, Relay Driver 32.
27. Send “C32lr” (Close Relay Driver 32) to the 73A-308.
28. Measure the voltage at P4 pin-49. The voltage will be the same as the +50 V source.
29. Send “Elr” (Enable all outputs) to the 73A-308.
30. Measure the voltage at P4 pin-49. The voltage will be less than +500 mV.
31. Send “R;E;Dir” (Reset, enable and then disable all outputs) to the 73A-308.
32. Disconnect all resistors and the +50 V power source from P4.
  - a. Connect the +50 V power source to P5 pin-50.
  - b. Connect one end of the 165  $\Omega$ , 15 W resistor to +50V, and the other end of the resistor to P5 pin-36, Relay Driver 40.
  - c. Connect the ground of the +50 V power source to P5 pin-4 and pin-5.
33. Send “C40lr” (Close Relay Driver 40) to the 73A-308.
34. Measure the voltage at P5 pin-36. The voltage will be the same as the +50 V source.
35. Send “Elr” (Enable all outputs) to the 73A-308.

36. Measure the voltage at P5 pin-36. The voltage will be less than +500mv.
37. Send “R;E;Dir” (Reset, enable and then disable all outputs) to the 73A-308.
38. Connect the 165  $\Omega$ , 15 W resistor from +50 V, to P5 pin-40, Relay Driver 48.
39. Send “C48ir” (Close Relay Driver 48) to the 73A-308.
40. Use a DMM and measure the voltage at the P5 pin 40. The voltage at the pin will be the same as the +50V source.
41. Send “Eir” (Enable all outputs) to the 73A-308.
42. Measure the voltage at P5 pin-40. The voltage will be less than +500 mV.
43. Send “R;E;Dir” (Reset, enable and then disable all outputs) to the 73A-308.
44. Connect the 165  $\Omega$ , 15 W resistor from +50V to P5 pin-43, Relay Driver 56.
45. Send “C56ir” (Close Relay Driver 56) to the 73A-308.
46. Measure the voltage at P5 pin-43. The voltage will be the same as the +50 V source.
47. Send “Eir” (Enable all outputs) to the 73A-308.
48. Measure the voltage at P5 pin-43. The voltage will be less than +500 mV.
49. Send “R;E;Dir” (Reset, enable and then disable all outputs) to the 73A-308.
50. Connect the 165  $\Omega$ , 15 W resistor from +50V, to P5 pin-46, Relay Driver 64.
51. Send “C64ir” (Close Relay Driver 64) to the 73A-308.
52. Measure the voltage at P5 pin-46. The voltage will be the same as the +50V source.
53. Send “Eir” (Enable all outputs) to the 73A-308.
54. Measure the voltage at P5 pin-46. The voltage will be less than +500 mV.
55. Send “R;E;Dir” (Reset, enable and then disable all outputs) to the 73A-308.
56. Connect the 165  $\Omega$ , 15 W resistor from +50 V, to P5 pin-49, Relay Driver 72.
57. Send “C72ir” (Close Relay Driver 72) to the 73A-308.
58. Measure the voltage at P5 pin-49. The voltage will be the same as the +50 V source.
59. Send “Eir” (Enable all outputs) to the 73A-308.

60. Measure the voltage at P5 pin-49. The voltage will be less than +500 mV.
61. Send “R;E;Dir” (Reset, enable and then disable all outputs) to the 73A-308.

## Triggering

This tests the TTLTRG lines on the VXI backplane.

Steps 2 through 8 verify that the output will not go active until a trigger is received on the selected TTLTRG line. The test uses Relay Output 72 and a 300 mA current supplied by a +5V power supply.

Step 3 programs the Trigger Setup to use TTLTRG 0 as the input trigger line that activates Relay Driver 72. The command also sets TTLTRG 0 as the output line. This line will output a trigger pulse on the Trigger command (step 6). Since TTLTRG line 0 is used as both the input and output, the output trigger pulse will be the trigger input pulse that activates Relay Driver 72.

Steps 3 and 4 ensure that the driver is not active until the trigger command is received in step 6.

Steps 8 through 14 test that only the selected TTLTRG input line will cause the output to go active. Step 9 programs the Trigger Setup to use TTLTRG 0 as the input trigger line that activates Relay Driver 72 and TTLTRG 1 as the output line.

Steps 2 through 14 test TTLTRG line 0 for input.

1. Connect +5 V power supply to P5 pin-17. Connect a 15  $\Omega$ , 3 W resistor from +5V to P5 pin-49, Relay Driver 72. Monitor pin-49 with a DMM. The voltage at pin-49 will be the same as the +5 V.
2. Send “R;E;Dir” (Reset, Enable and then Disable) to the 73A-308.
3. Send “TS 0,0lf” ( Trigger Setup, TTLTRG0 IN, TTLTRG0 OUT) to the 73A-308.
4. Send “C72;Eif” (Close Relay Driver 72, Enable outputs) to the 73A-308.
5. The voltage at pin-49 will remain at +5 V.
6. Send “Tlf” (Trigger) to the 73A-308.
7. The voltage at pin-49 will be below 500 mV.
8. Send “R;E;Dir” (Reset, Enable and then Disable) to the 73A-308.
9. Send “TS 0,1lf” ( Trigger Setup, TTLTRG0 IN, TTLTRG1 OUT) to the 73A-308.
10. Send “C72;Eif” (Close Relay Driver 72, Enable outputs) to the 73A-308.
11. The voltage at pin-49 will remain at +5 V.

12. Send “Tlf” (Trigger) to the 73A-308.
13. The voltage at pin-49 will remain at +5 V.
14. Send “R;E;Dlf” (Reset, Enable and then Disable) to the 73A-308.

Repeat steps 2 thru 14 for each TTL trigger line 0–7 by substituting the TTL in and TTL out line of the TS command.

### **Interrupts Test**

This test the capability of the 73A–308 to generate interrupts on the VXI backplane.

1. Send “R;E;Dlf” (Reset, Enable and then Disable) to the 73A-308.
2. Send a WORD SERIAL COMMAND “Read STB” (command 0xCFFF) to the 73A-308 and the query byte returned will have bit 6 cleared ignore all other bits. If this is the case then an interrupt has not been generated, otherwise the test failed.
3. Send “IElf”(Enable interrupts on syntax errors) to the 73A-308.
4. Send “ASASASlf”(illegal command) to the 73A-308.
5. Send a WORD SERIAL COMMAND “Read STB” (command 0xCFFF) to the 73A-308 and the query byte returned will have bit 6 set (decimal 64) ignore all other bits. If this is the case then an interrupt has been generated, otherwise the test failed.
6. Send “R;E;Dlf” (Reset, Enable and then Disable) to the 73A-308.
7. Send a WORD SERIAL COMMAND “Read STB” (command 0xCFFF) to the 73A-308 and the query byte returned will have bit 6 cleared ignore all other bits. If this is the case then an interrupt has not been generated, otherwise the test failed.
8. Send “TS 0,0lf” ( Trigger Setup, TTLTRG0 IN, TTLTRG0 OUT) to the 73A-308.
9. Send “ITlf”(Enable interrupts on external trigger) to the 73A-308.
10. Send “C72;Elf” (Close Relay Driver 72, Enable outputs) to the 73A-308.
11. Send “Tlf” (Trigger) to the 73A-308.
12. Send a WORD SERIAL COMMAND “Read STB” (command 0xCFFF) to the 73A-308 and the query byte returned will have bit 6 set (decimal 64) ignore all other bits. If this is the case then an interrupt has been generated, otherwise the test failed.
13. Send “R;E;Dlf” (Reset, Enable and then Disable) to the 73A-308.







## Artisan Technology Group is your source for quality new and certified-used/pre-owned equipment

- FAST SHIPPING AND DELIVERY
- TENS OF THOUSANDS OF IN-STOCK ITEMS
- EQUIPMENT DEMOS
- HUNDREDS OF MANUFACTURERS SUPPORTED
- LEASING/MONTHLY RENTALS
- ITAR CERTIFIED SECURE ASSET SOLUTIONS

### SERVICE CENTER REPAIRS

Experienced engineers and technicians on staff at our full-service, in-house repair center

### *InstraView*<sup>SM</sup> REMOTE INSPECTION

Remotely inspect equipment before purchasing with our interactive website at [www.instraview.com](http://www.instraview.com) ↗

### WE BUY USED EQUIPMENT

Sell your excess, underutilized, and idle used equipment. We also offer credit for buy-backs and trade-ins. [www.artisanng.com/WeBuyEquipment](http://www.artisanng.com/WeBuyEquipment) ↗

### LOOKING FOR MORE INFORMATION?

Visit us on the web at [www.artisanng.com](http://www.artisanng.com) ↗ for more information on price quotations, drivers, technical specifications, manuals, and documentation

**Contact us:** (888) 88-SOURCE | [sales@artisanng.com](mailto:sales@artisanng.com) | [www.artisanng.com](http://www.artisanng.com)