

# FLOALARM rel. 1.2

## Alarm System

### K4 / K8



## User manual

September 2013



Spectron Gas Control Systems GmbH  
 Fritz-Klatte-Str. 8 - 65933 Frankfurt / Main – Germany  
 Tel. +49 (0)69 - 38016 - 0 \* Fax +49 (0)69 - 38016 - 200

# TABLE of CONTENTS

**OVERVIEW**..... 2

**SET-UP** ..... 3

    CONNECTING POWER SUPPLY..... 3

    CONNECTING INPUTS ..... 3

    CONNECTING RELAY OUTPUT ..... 3

    FIRST POWER-UP ..... **FEHLER! TEXTMARKE NICHT DEFINIERT.**

**PROGRAMMING** ..... 4

**OPERATION** ..... 6

    ALARM MANAGEMENT..... 6

    TEST AND PROGRAMMING CHECK..... 7

    NO / INVALID SETUP PARAMETERS ..... 7

    SUMMARY OF OPERATIONS ..... 8

**MECHANICAL INFORMATION**..... 9

**ELECTRICAL CONNECTIONS**..... 10

**TECHNICAL CHARACTERISTICS**..... 11

**DECLARATION OF CONFORMITY**..... 12

## OVERVIEW

FLOALARM is especially conceived to monitor alarm conditions in compressed gas storages and supply pipelines.

Two types are available: K4 with four alarm inputs and K8 with eight alarm inputs.

All alarm inputs are compatible with popular switch sensors and inductive proximity sensors type Namur.

The alarm status is testified by visual and acoustic signals.

Visual signals include 4 (8) red leds, associated to each alarm input.

Blinking status of red led testifies that the corresponding alarm input is active and this alarm condition is still unacknowledged.

Fixed lighted status of red led testifies that the corresponding alarm input is active and this alarm condition was already acknowledged.

Acoustic signal indicates one or more unacknowledged alarm conditions.

All current unacknowledged alarm conditions become acknowledged and the acoustic signal switches off by pushing CANCEL HOOTER pushbutton.

The TEST pushbutton starts the standard test of all signaling devices and the programming check cycle. A relay output is available to drive an additional hooter or an external alarm indicator. All programming functions can be set and modified by two pushbuttons on the front panel.

## SET-UP

**WARNING!** – For safety reasons, the installing operations must be performed in accordance with the instructions of this manual, by qualified operators only; disconnect power supply line from the equipment before opening the housing. The manufacturer rejects whichever responsibility for accidents or damages due to negligence of these recommendations. For use with flammable gases or input signals from ex-protected areas the European Directive 94/9/EC (ATEX) must be observed.

Signal sources in ex-protected areas must only be operated on intrinsically safe signal circuits using suitable safety barriers.

Notice: The FLOALARM-unit must be installed outside the ex-protected area!

### Connecting Power Supply

Use 1.5 mm<sup>2</sup> section cables.

Put a 2 A bipolar security interrupter on the power supply line.

### Connecting Inputs

Connect each sensor using bipolar 0.25 – 0.5 mm<sup>2</sup> section cable.

Shielded cables with shields connected to earth are suggested, but not mandatory.

### Connecting Relay Output

Use 0.5 to 1.5 mm<sup>2</sup> section cables, in function of switching current and line length.

Don't forget that maximum working voltage is 220 Vac and maximum current 1 A for this output.

## PROGRAMMING

Programming parameters can be set or modified by the pushbuttons on the front panel.

You can set operation and delay of each alarm input, besides buzzer and relay output operation.

Tables below show the alarm condition related to the input operation and delay for both sensor types and supply some suggestions about remaining setting.

### *Alarm inputs*

PROGRAMMING PARAMETER	ALARM CONDITION FOR	
	SWITCH SENSOR	INDUCTIVE NAMUR
Normally Closed (NC)		
Normally Open (NO)		
No delay	Immediate	
Delay 2 sec	Delayed 2 seconds	

### *Buzzer*

OPERATION	SUGGESTIONS
Continue	Use this setting if the alarm equipment is placed outdoor or in industrial environments and, in general, when the maximum volume is required.
Pulse	Use this setting if the alarm equipment is placed in site habitually frequented by people and, in general, when a moderate volume is required.
OFF	Use this setting to disable the alarm sound.

### *Relay output*

OPERATION	SUGGESTIONS
Buzzer repeater	Use this setting to drive an additional external hooter in case one or more unacknowledged alarm conditions are in progress.
Cumulative alarm	Use this setting to drive an additional external alarm indicator. Logic N.C.

Push and hold **TEST** pushbutton: system starts test and programming check cycle then, after about 10 seconds, switches OFF all leds.

Release **TEST** button after leds switch off: the system enters the programming mode and begins step 1 of the programming sequence.

During programming sequence, push **CANCEL HOOTER** to select the desired option, push **TEST** to confirm current setting and jump to next step;

**Programming sequence**

Step	Prg Function	User Interface	First Option (default)	Second Option	Third Option
1	<b>Input 1 Operation</b>	LED 1 →	<b>Normally Open</b> fixed light	<b>Normally Closed</b> fast blinking	----
2	<b>Input 1 Delay</b>	LED 1 = ON Buzzer →	<b>No delay</b> Short buzz	<b>Delay 2 sec</b> Long buzz	----
3	<b>Input 2 Operation</b>	LED 2 →	<b>Normally Open</b> fixed light	<b>Normally Closed</b> fast blinking	----
4	<b>Input 2 Delay</b>	LED 2 = ON Buzzer →	<b>No delay</b> Short buzz	<b>Delay 2 sec</b> Long buzz	----
5	<b>Input 3 Operation</b>	LED 3 →	<b>Normally Open</b> fixed light	<b>Normally Closed</b> fast blinking	----
6	<b>Input 3 delay</b>	LED 3 = ON Buzzer →	<b>No delay</b> Short buzz	<b>Delay 2 sec</b> Long buzz	----
7	<b>Input 4 operation</b>	LED 4 →	<b>Normally Open</b> fixed light	<b>Normally Closed</b> fast blinking	----
8	<b>Input 4 Delay</b>	LED 4 = ON Buzzer →	<b>No delay</b> Short buzz	<b>Delay 2 sec</b> Long buzz	----
----	----	----	----	----	----
9 (17)	<b>Buzzer Operation</b>	All LEDs OFF Buzzer →	<b>Continue mode</b> Continue tone	<b>Pulse mode</b> Pulse tone	<b>Disabled</b> Off
10 (18)	<b>Relay OUT Operation</b>	All LEDs = ON Buzzer →	<b>Buzzer repeater</b> Pulse tone	<b>Cumulative Alarm</b> OFF	----
<i>EXIT from PROGRAMMING MODE - RETURN to RUNNING MODE</i>					

The exit from Programming Mode occurs at the end of the programming sequence or by the 30-seconds key-timeout.

The exit by timeout also preserves all previous changes, except for those corresponding to the current input.

For example: if timeout occurs while the system stands in step 8, only previous modifications concerning the inputs 1, 2 and 3 will be preserved.

On the contrary, the exit by timeout does not recover a NO / INVALID SETUP PARAMETERS condition (refer to corresponding section).

## OPERATION

### Alarm management

The standard alarm sequence includes three steps:

**Case 1:** acknowledgement before the end of the alarm event

- Start of alarm event:** input switches from normal to alarm condition. Buzzer switches on and the corresponding alarm led becomes blinking, indicating an unacknowledged alarm status.
- Alarm acknowledgement:** user pushes **CANCEL HOOTER** pushbutton. Buzzer stops and alarm led switches from blinking to fixed, indicating an acknowledged alarm status.
- End of alarm event:** input switches from alarm to normal condition. Alarm led switches from fixed to off.

**Case 2:** acknowledgement after the end of the alarm event

- Start of alarm event:** input switches from normal to alarm condition. Buzzer switches on and the corresponding alarm led becomes blinking, indicating an unacknowledged alarm status.
- End of alarm event:** input switches from alarm to normal condition. Same signals continue, system remains in previous alarm status.
- Alarm acknowledgement:** user pushes **CANCEL HOOTER** pushbutton. Buzzer stops and alarm led turns off.

The alarm management is “with memory”; namely, if the end of the alarm event occurs before the acknowledgement, the equipment remains in unacknowledged alarm status, until the acknowledgement.

Acknowledgement operation is effective over all the current alarms.

### Test and Programming check

Pushing **Test** button, system turns on all alarm leds, relay and buzzer for three seconds (standard test), then shows current programming parameters through the signaling sequence described in table below.

The duration of each step is about three seconds

**Programming check sequence**

<u>Step</u>	<u>Checking</u>	<u>Function Signaling</u>	<u>First Option</u>	<u>Second Option</u>	<u>Third Option</u>
1	Input 1	<b>Operation</b> Led 1 →	<b>NC</b> fast blinking	<b>NO</b> fixed light	----
		<b>Delay</b> Buzzer →	<b>Delayed</b> Long buzz	<b>No delay</b> Short buzz	----
2	Input 2	<b>Operation</b> Led 2 →	<b>NC</b> fast blinking	<b>NO</b> fixed light	----
		<b>Delay</b> Buzzer →	<b>Delayed</b> Long buzz	<b>No delay</b> Short buzz	----
3	Input 3	<b>Operation</b> Led 3 →	<b>NC</b> fast blinking	<b>NO</b> fixed light	----
		<b>Delay</b> Buzzer →	<b>Delayed</b> Long buzz	<b>No delay</b> Short buzz	----
4	Input 4	<b>Operation</b> Led 4 →	<b>NC</b> fast blinking	<b>NO</b> fixed light	----
		<b>Delay</b> Buzzer →	<b>Delayed</b> Long buzz	<b>No delay</b> Short buzz	----
----	----	----	----	----	----
5 (9)	Buzzer	<b>Operation</b> Buzzer → All LEDs OFF	<b>Continue</b> Continue tone	<b>Pulse</b> Pulse tone	<b>Disabled</b> OFF
6 (10)	Relay OUTPUT	<b>Operation</b> Buzzer → All LEDs ON	<b>Buzzer repeater</b> Pulse tone	<b>Cumulative al.</b> Always OFF	----

### No / invalid setup parameters

After a programming error or before first programming, the programming parameters in memory are invalid or missing. In this condition, the system does not operate and flashes all alarm leds periodically.

Perform a full programming sequence to restart the system (refer to FIRST POWER-UP section for details).

### Summary of operations

#### **Visual and acoustic signals in working mode**

<u>DEVICE</u>	<u>STATUS</u>	<u>CONDITION</u>
<b>Alarm led 1(.... 8)</b>	OFF	Normal condition 1(.... 8)
	<i>Blinking</i>	Unacknowledged alarm 1(.... 8)
	<i>fixed lighted</i>	Acknowledged alarm 1(.... 8)
	<i>flashing (all alarm leds)</i>	No or invalid setup parameters
<b>Buzzer</b>	OFF	No or acknowledged alarms / Disabled
	ON	One or more unacknowledged alarms

#### **Buzzer operation**

<u>BUZZER SETTING</u>	<u>OPERATION IN ON STATUS</u>
<b>Continue tone</b>	always ON
<b>Pulse tone</b>	0.5 sec ON / 1.5 sec OFF
<b>Disabled</b>	Always OFF

#### **Output Relay operation**

<u>RELAY SETTING</u>	<u>OPERATION</u>
<b>Buzzer repeater</b>	Follows the status of the buzzer as shown in table above, without consideration for the buzzer setting
<b>Cumulative alarm relay</b>	OFF if one or more alarms are in progress
	ON if no alarm are in progress

### Mechanical information

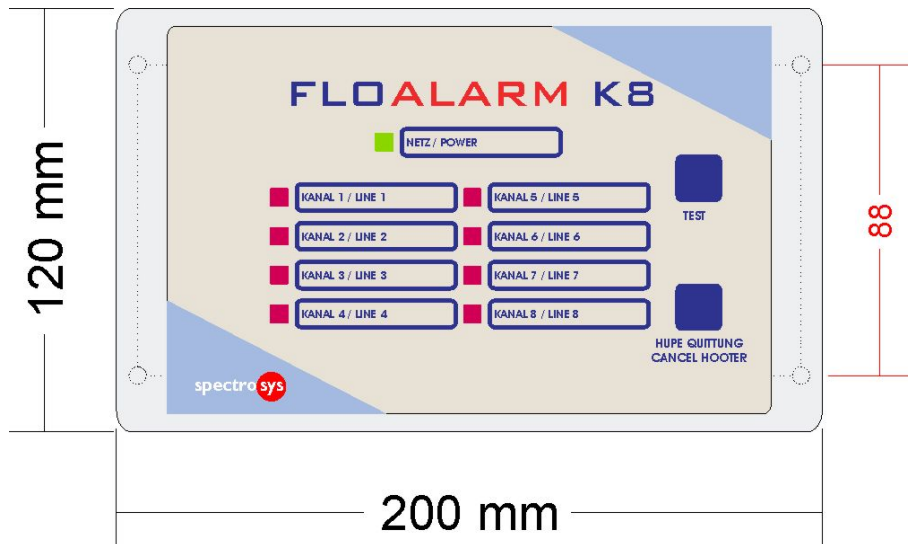
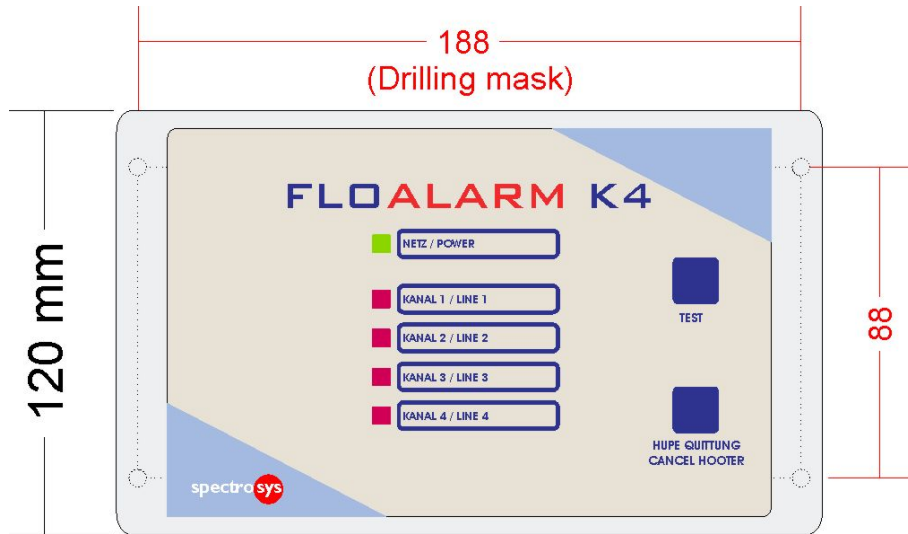

### Electrical connections

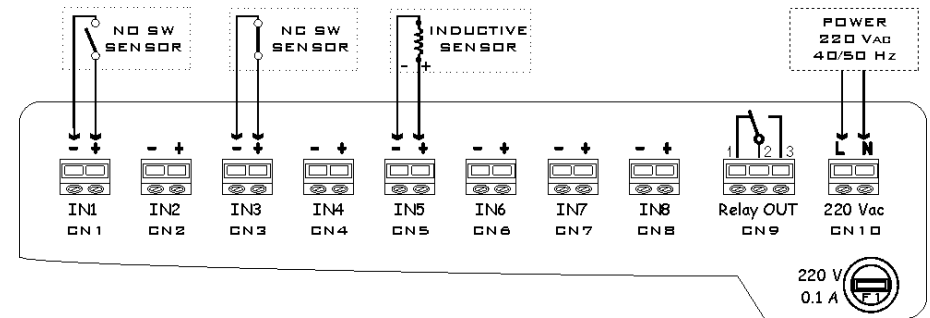

#### Warning

Each sensor must be directly connected to the corresponding screw connector only and using both wires. Avoid connections different from that shown in diagram above.

**CN1 – CN8  
Alarm inputs**

Pin	Mechanical switch sensor	Solid state switch sensor	Inductive sensor NAMUR type normal / ATEX
-	COM	-	- white cable / - blue cable
+	NO or NC	+	+ brown cable/ + brown cable

**CN9  
Relay Output**

Pin	Signal
1	NC
2	COM
3	NO

**CN10  
Supply 220 Vac**

Pin	Signal
L	220 Vac – (L)
N	220 Vac – (N)

## TECHNICAL CHARACTERISTICS

<b>INPUTS specifications</b>	V(max) = 15 Vdc; I(max) = 20 mA	
<b>INPUTS compatibility</b>	Standard mechanical switch sensors Solid state PNP / NPN switch sensors, DC only Inductive proximity sensors type NAMUR	
<b>RELAY OUTPUT</b>	V(max) = 220 Vac; I <sub>max</sub> = 1 A NO and NC contacts available	
<b>SUPPLY VOLTAGE</b>	220 Vac / 50-60 HZ, P(max) = 8 VA	
	<b>Fuse</b>	220 V / 0.1 A
<b>HOUSING</b>	IP65 plastic box for wall mounting K4 type: 200 x 120 x (h) 57 mm K8 type: 200 x 120 x (h) 77 mm	
	<b>Namur specifications</b>	
<b>SUPPLY VOLTAGE</b>	5 Vdc < +Vs < 25 Vdc	
<b>LOAD CURRENT</b>	<i>Target Present</i>	IL < 1mA
	<i>Target Absent</i>	3mA < IL < 15 mA

Made by: AMBRA Sistemi s.r.l. Grugliasco (TO) Italy



Sistemi s.r.l.

Grugliasco, September 06<sup>th</sup>, 2013

<b>Manufacturer name</b>	AMBRA SISTEMI s.r.l.
<b>Manufacturer address</b>	125, Strada del Portone I-10095 GRUGLIASCO TO

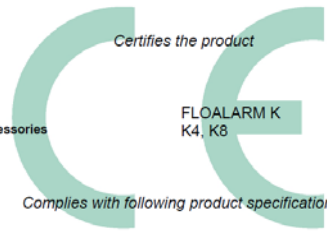

Certifies the product

**Product name** FLOALARM K  
**Options and accessories** K4, K8

Complies with following product specifications:

EN 61000-6-1: 2007	EMC Generic standard Immunity for residential, commercial and light-industrial environments
EN 61000-6-3: 2007	EMC Generic standard Emission standard for residential, commercial and light-industrial environments

DECLARATION  
of  
CONFORMITY  
in accordance with  
ISO/IEC – Guide 22  
EN 45014

**Additional notes:**

- ⇒ The included products comply with Low Voltage Directive 2006/95/CE
- ⇒ The included products comply with EMC Directive 2004/108/CE
- ⇒ All tests are performed in typical configuration.

Claudio Guidotti  
Technical manager



**AMBRA Sistemi s.r.l. – 125, Strada del Portone – I-10095 Grugliasco (TO) ITALY**  
 Phone: +39 011 967.77.75 – Fax: +39 011 967.77.25 – E-mail: [info@ambrasistemi.it](mailto:info@ambrasistemi.it) – <http://www.ambrasistemi.it>