

2 phase stepping motor driver

NanoDrive

SND100 series

【 User's manual 】

m4com

Safety precautions

Please read this operation manual thoroughly before starting any operation. This manual will guide the customers for proper use and avoid any mis-operation. This manual if properly read, will protect the users as well as other people from possibilities physical injuries, property damage and other serious accidents.



DANGER

Indicates a possibility of causing serious injury or worst, death to the user, caused by fire or electric shock if this warning is ignored. Also indicates that the equipment has the highest degree of causing damage.



WARNING

This shows the possibility that the user may get serious injury by fire or electrical shock if this warning is neglected.



CAUTION

This shows the possibility that may cause slight injury or damage to this product or other equipment.

DANGER

- Do not operate this product if it is damaged or disassembled. Otherwise, it may cause fire or electrical shock.
- In any case, do not attempt to repair or modify this product as it may cause fire, electrical shock or serious injuries.
- Do not use this product, in a place where the air includes a corrosive gas, inflammable gas, or any type of explosive gas, or the water or oil splashes, or it is near a flammable material. Otherwise, it may cause fire or electrical shock.
- Leave works such as installation, wiring, operation, checking and maintenance to experts who have enough knowledge on this product. Operation without knowledge may cause electrical shock and other serious physical or property damages.
- Keep the power supply within the rated voltage range. Otherwise, it may cause fire or other damages.
- Make sure all the connections correctly done referring to the wiring diagram shown in this user's manual. Otherwise, it may cause fire or other damages.
- Do not, in any circumstances, touch the terminal block while the power is on as there are some terminals which high voltage appeared. Otherwise, it may cause electrical shock.
- Do not touch or place objects such as metals or foreign substance on the board. Otherwise, it may cause fire or electrical shock.
- Do not bend, pull or place the power or motor cables by the extreme force. Otherwise, it may cause fire or electrical shock.
- Do not make a mistake connecting the motor output terminals to protective earth or power supply. Otherwise, it may cause fire.

- Do not do the driver's installation preventing ventilation. Otherwise, it may cause fire.
- When the "HEAT" is activate, stop the pulse signal. Otherwise, it may cause fire. (Only the product have a Overheat function.)

 **WARNING**

- Do not attempt any type of works such as moving the machine, wiring, maintenance, checking while the power is on. It is recommended that such works should be done only when more than ten seconds have elapsed after the power is off. Otherwise, it may cause electrical shock.
- Do not touch this product with wet hands while the power is on. Otherwise, it may cause electrical shock.
- Connect the protective earth terminal (PE) properly to it on your equipment, as illustrated in this user's manual. Otherwise, it may cause electrical shock.
- Use this product which installed properly in the enclosure. Otherwise, it may cause electrical shock or injury.
- Do not leave the cover off from the terminal block while the power is on. Otherwise, it may cause electrical shock or injury.
- Fix this product securely onto your equipment. Otherwise, it may cause injury.
- Do not touch this product while it is running or right after it is stopped. Otherwise, it may cause injury, as its surface remains hot.
- Depending on the setting of this product, it may show an unexpected operation when recovering from overheating. Please read this user's manual carefully and pay a special attention.
- Use a DC power supply with reinforced insulation for dangerous voltage. Otherwise, it may cause electrical shock.(Only DC input type)

 **CAUTION**

- Do not use or store this product under a dusty environment. Otherwise, it may cause malfunction.
- Do not give a big shock to this product. Otherwise, it may cause malfunction.
- Do not use or store this product in a place of high or low temperature, or under an environment of extremely high or low humidity. Otherwise, it may cause short circuit to your device or further damage.
- Do not install this product in a place where a dew is generated. Otherwise, it may cause short circuit to your device or further damage.
- MYCOM is, in no way, responsible for any damages or malfunctions that are caused by user's repair or modifications on this driver. If the user performed these initiations and the driver does not work satisfactorily, a warranty will not be provided.
- When giving up the use of the driver, dispose it according to an appropriate regulation on the industrial waste.
- Please do not remove the name plate.

INDEX

1. Specification of driver.....	1
SND100-220L	1
2. Model number & Factory default.....	2
2-1. Model number of set.....	2
2-2. Factory default	2
3. Pulse waveform.....	3
3-1. Input pulse type	3
3-2. Pulse waveform	3
4. Each part name and functions.....	4
4-1. Each part name	4
4-2. Description of function.....	4
4-2-1. Power display LED (POWER).....	4
4-2-2. Resolution select switch (SW 1st - 4th pole)	5
4-2-3. Auto current down function (A.CD, SW 5th pole).....	6
4-2-4. Pulse input type select switch(1P/2P, SW 6th pole).....	6
4-2-5. Driving current adjusting volume (C.ADJ).....	6
4-2-6. Power supply connector (CN-1).....	7
4-2-7. Motor connector (CN-2).....	7
4-2-8. Signal input connector (CN-3).....	7
5. Example Of connection.....	7
6. Wiring and Install condition.....	8
6-1. Wiring for power lines.....	8
6-2. Wiring for motor lines.....	8
6-3. Wiring of signal line	8
6-4. Install condition	8
7. How to Current Adjustment	9
7-1. Connection and adjustment procedure	9
8.Dimension.....	10
8-1. Dimension of SND100-220L.....	10
9. Option.....	11

1. Specification of driver

SND100-220L

Driver model name	SND100-220L
Power source	DC24V \pm 10%
Power consumption	85W or less
Driving type	Uni-polar constant current type
Output current	2.0A/phase MAX
Resolution	Basic step : 1, 2, 2.5, 5, 8, 10, 20, 25, 40, 50, 100, 125, 200, 250, 500, 1000
Function	Auto-current down
Signal input	Photo coupler input; Input resistance 220 Input signal voltage : L : 0 - 0.5V, H : 4 - 5V 1 pulse(PLUSE, CW/CCW), 2 pulses(CW, CCW)
Insulation resistance	100M or more applied DC 500V megger in normal temperature and humidity. <ul style="list-style-type: none"> • Power input : Motor leads collection terminal - chassis • Power input : Motor leads collection terminal - signal I/O
Operating environmental temperature	0 to +40 No freezing
Operating environmental humidity	Less than 80%, No condensation
Storing environmental temperature	-10 to +60 No freezing
Storing humidity	Less than 80%, No condensation
Operating height	Less than 1,000m from sea level
Atmosphere	In the room without corrosive gas, inflammable gas and dust. Without splashing water and oil
Weight	120g
Accessories	User's manual(This book)

2. Model number & Factory default

2-1. Model number of set

SND100 - 220L - 268A

Series name

Extension of set

List of motor and driver combination

Series name, SND100		
Extension of set	Motor model	Current A/phase
243A(B)	PF243-A(B)	0.9
244A(B)	PF244-A(B)	1.2
245A(B)	PF245-A(B)	1.2
264A(B)	PF264-A(B)	2.0
265A(B)	PF265-A(B)	2.0
268A(B)	PF268-A(B)	2.0
444A(B)	PS444-02A(B)	0.8
443A(B)	PS443-01A(B)	0.95
445A(B)	PS445-01A(B)	1.2
464A(B)	PF464-02A(B)	2.0
466A(B)	PF466-02A(B)	2.0
468A(B)	PF468-02A(B)	2.0

2-2. Factory default

Driver model number	SND100-220L
Phase current	2.0 A/phase Max
Current down value	1.0 A/phase
Auto current down function	Auto current down function, valid
Input type	2 pulse type
Resolution	1/1(FULL)

3. Pulse waveform

3-1. Input pulse type

2 pulses type
Timing chart

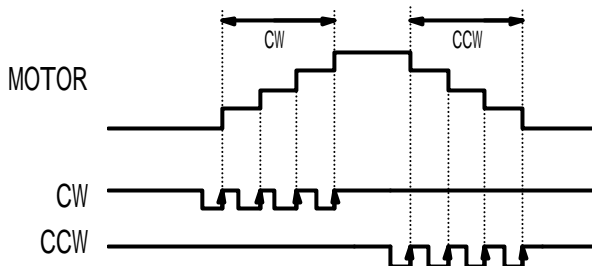

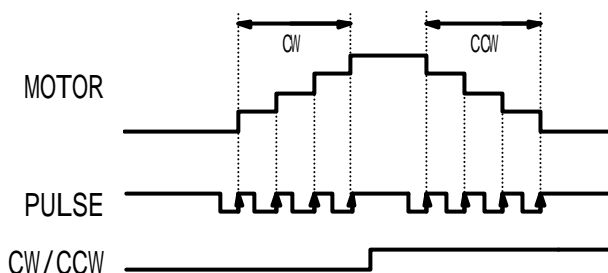

1 pulse type
Timing chart

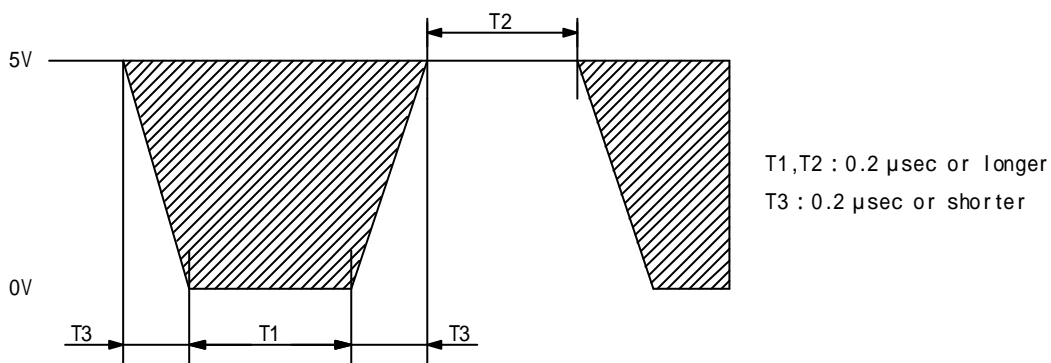

3-2. Pulse waveform

Please input the pulse signal of the below shown waveform.



 This section shows "ON" status of internal photo coupler.
Motor starts to rotate by rising edge of waveform.

4. Each part name and functions

4-1. Each part name

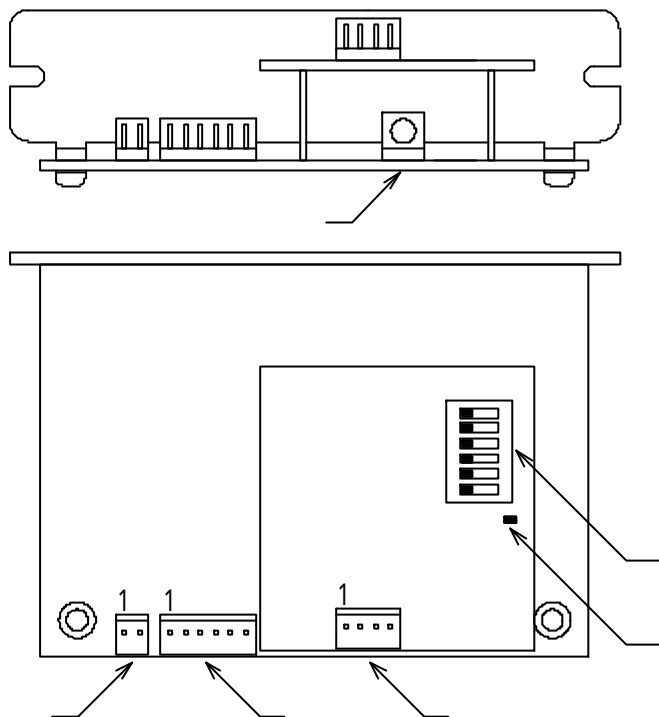

Power display LED (POWER)

This lights on during power on.

Power connector(CN-1)

This connects to power

Motor connector (CN-2)

Connect in accordance with the color of motor leads.

Signal I/O connector(CN-3)

Various I/O signals are connected.

Switching

- Resolution select switch: 1st-4th pole

This selects the resolution.

- Switching of Auto current down function (A.CD) : 5th pole

This turns on/off the auto current down function.

- Switching of input pulse input (1P/2P) : 6th pole

This switches the input pulse type.

Current adjust volume for current (C.ADJ)

This adjusts the current when current.

4-2. Description of function

4-2-1. Power display LED (POWER)

This lights on during power on.

4-2-2. Resolution select switch (SW 1st - 4th pole)

Resolution select switch(4-1.Each Part name , SW 1st-4th pole) can set 16 various resolutions individually.

	Resolution
No. 1	1/1
No. 2	1/2
No. 3	1/2.5
No. 4	1/5
No. 5	1/8
No. 6	1/10
No. 7	1/20
No. 8	1/25
No. 9	1/40
No. 10	1/50
No. 11	1/100
No. 12	1/125
No. 13	1/200
No. 14	1/250
No. 15	1/500
No. 16	1/1000

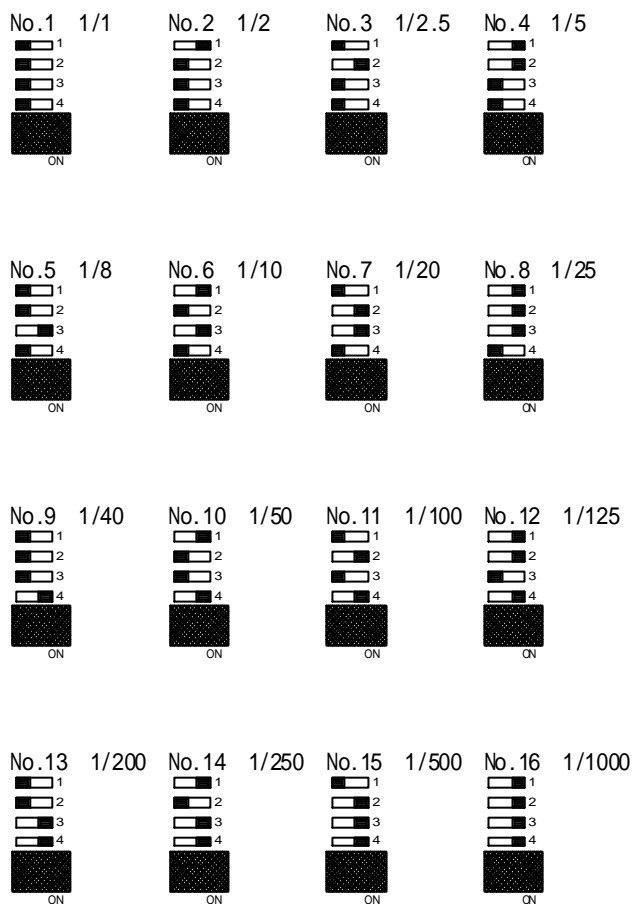

4-2-3. Auto current down function (A.CD, SW 5th pole)

This automatically reduces the motor driving current to 50%(default) of normal current to reduce temperature rising of motor after the motor stops and 200ms. later.

OFF/A.CD switch (4-1. Each part name , SW 5th pole) can release the function.

Auto current down valid

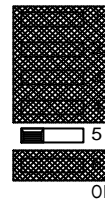

Auto current down invalid

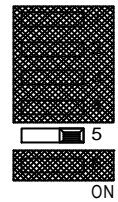

4-2-4. Pulse input type select switch(1P/2P, SW 6th pole)

1P/2P switch sets the driving pulse to 1 pulse type or 2 pulses type.

(4-1. Each part name , SW 6th pole) Please refer “3. Pulse wave” about input type.

1 pulse type



2 pulse type

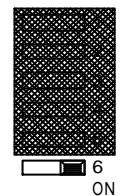

⚠ CAUTION

- When automatic current down release is carried out, compulsive air cooling is required for the driver.
- When automatic current down release is carried out, be careful of heat generation of a motor and a driver.

4-2-5. Driving current adjusting volume (C.ADJ)

C.ADJ volume (4-1. Part name) adjusts the value of motor driving current.

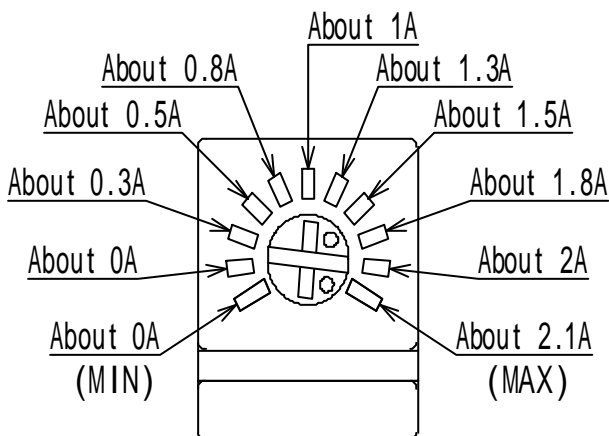

Left figure shows the position of volume adjusted about 2A.

⚠ Attention

- The above figure of volume is approximate value.
- There is a possibility to flow over current if volume is turned into the end position(MAX) of clockwise direction. Pay attention for the heating of a motor and a driver.

4-2-6. Power supply connector (CN-1)

DC24V and 0V are connected.

Connector pin assignment	
1	DC24V
2	0V

4-2-7. Motor connector (CN-2)

This is connected according to the motor lead color.

Connector pin assignment			
1	ACOM	4	/A phase
2	BCOM	5	B phase
3	A phase	6	/B phase

4-2-8. Signal input connector (CN-3)

This is to be connected with driving pulse signal.

1 pulse mode

1	PULSE+
2	PULSE -
3	CW/CCW+
4	CW/CCW -

2 pulses mode

1	CW+
2	CW -
3	CCW+
4	CCW -

5. Example Of connection

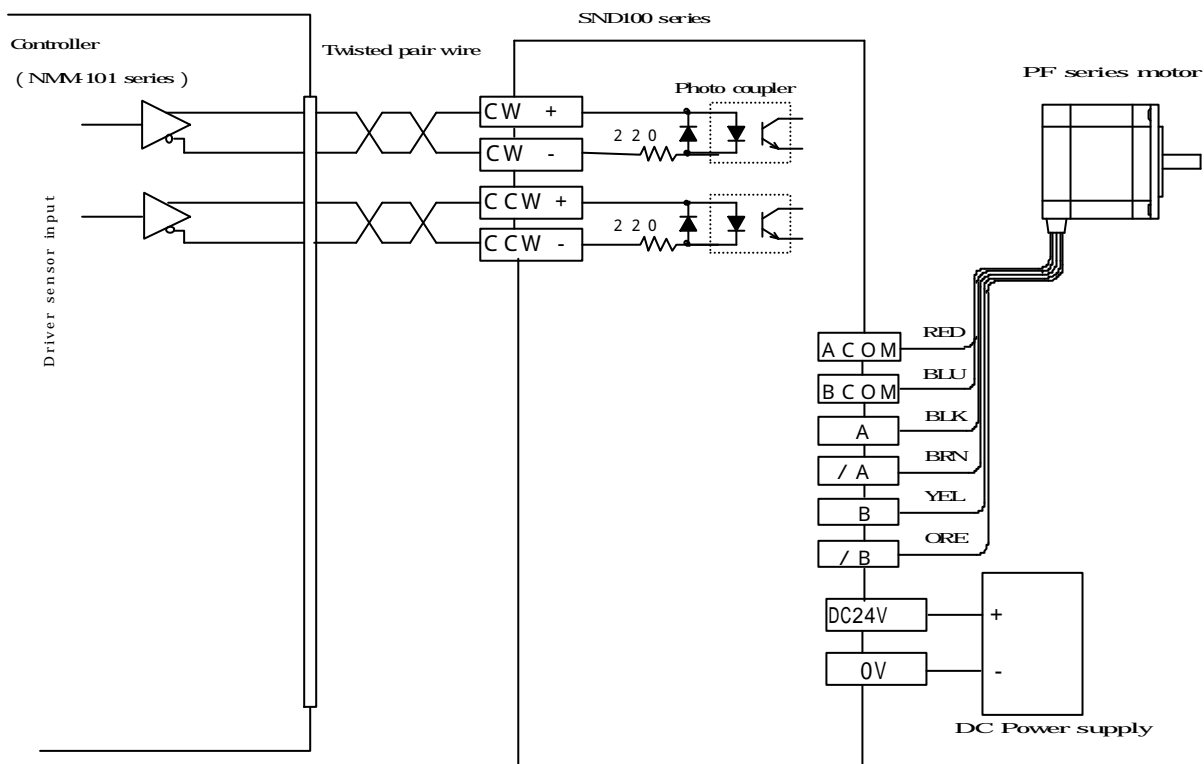

6. Wiring and Install condition

6-1. Wiring for power lines

- Install noise filter at power input where noise sources exist near the driver or there are effects of power noise.

6-2. Wiring for motor lines

- The radiant noise may be avoided by sealed line if unnecessary radiation causes troubles.

6-3. Wiring of signal line

If the following procedure is not made, there may be a cause of incorrect operation.

- Use bigger cable than AWG28 which suits with the connector.
- Use twisted pair line or shield line.

6-4. Install condition

- Use in control box.
- Fix the driver on heat conductive earthed metal plate tightly.
- Put 3cm or more space between each driver and fix the drivers when multiple drivers are arranged.
- Because this unit uses high speed photo coupler for the part of input pulse, use the shield line for signal cable. Also do not connect the signal line which is not used. It becomes the cause of incorrect operation.
- Use M3 screws of length of “thickness of installing place plus 3mm”.

Attention

There is a possibility that driver heat sink temperature exceeds 60 centimeter degree depending on loading or environmental condition.

7. How to Current Adjustment

7-1. Connection and adjustment procedure

- As shown in the figure below, connect ACOM and BCOM of driver with “+” of ammeters. Connect ACOM and BCOM of motor with “-” of ammeters.
- Power driver on after turning C.ADJ volume until MIN position, which is end of clockwise direction, and setting resolution 1/1.
- Turn auto-current down OFF (invalid)
- Adjust driving current by C.ADJ volume.
Adjust the current to double value of motor rated current.
As shown in the connection figure below, in case that the rated current of motor is 2A, twice of rated current are required to adjust the current for two phase by one ammeter.

Ex. In case that the rated current of motor is 2A,
 $2A \times 2 = 4A$

Ex. In case that the rated current of motor is 1.2A,
 $1.2A \times 2 = 2.4A$

- Turn auto-current down ON (valid)

Attention

- Make sure the rating of ammeters and connect to motor and driver.
- Connect two “COM” with ammeters without fail.
- There is a possibility to flow over current if volume is turned into the end position(MAX) of clockwise direction.)

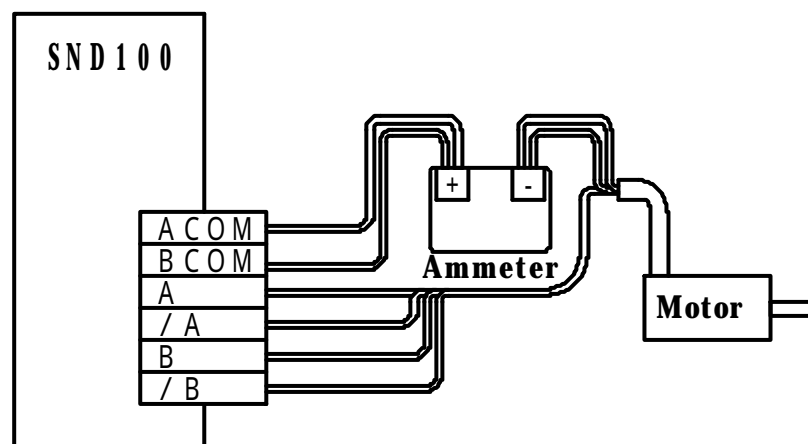

8.Dimension

8-1. Dimension of SND100-220L

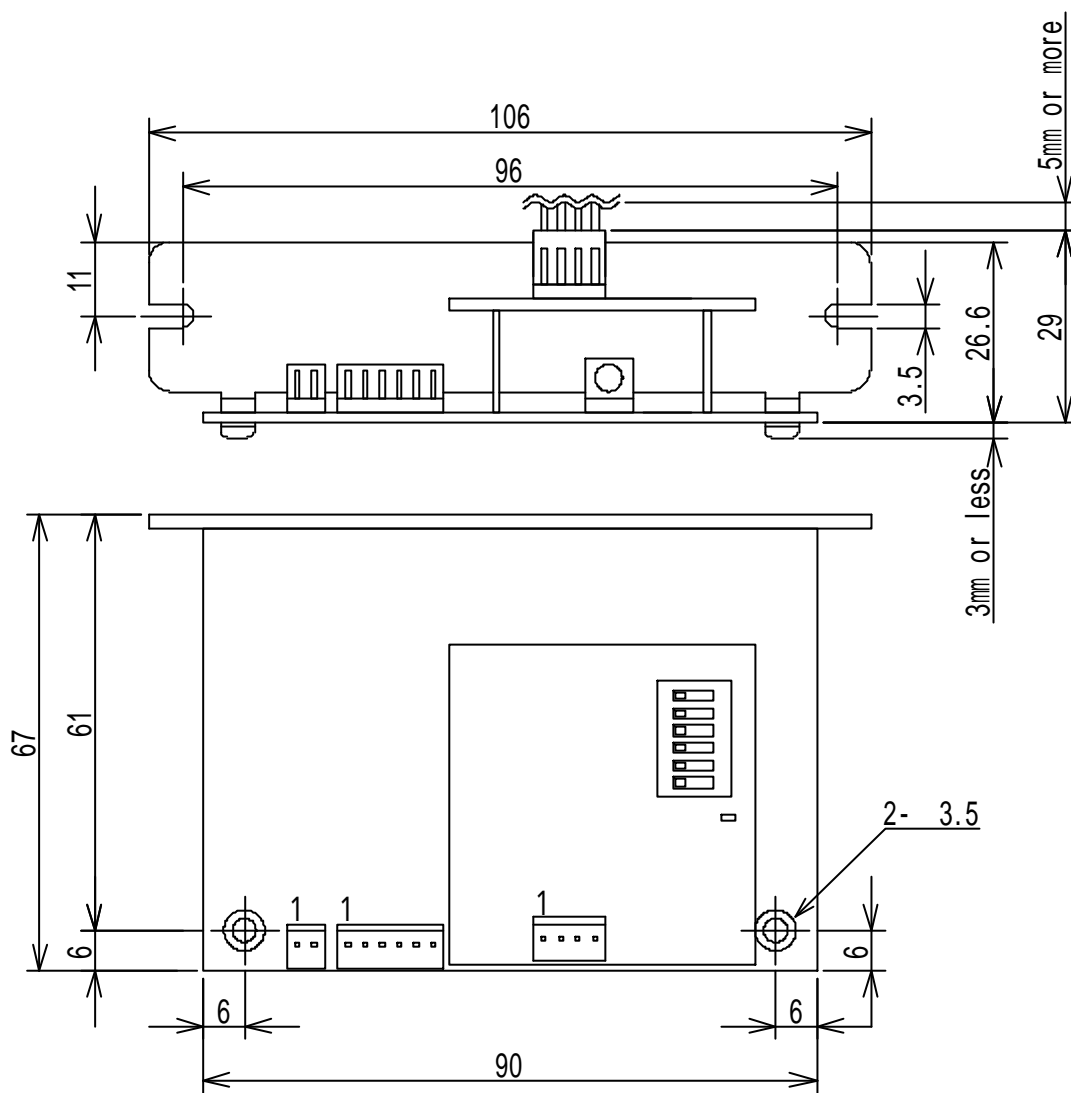

Unit: mm. (The screw head is not included.)

9. Option

It is available to supply the following optional cables which have covering connector at the one side.

- CN1 : Power cable

Model number : OPC-IL2P3

Connector : IL-G-2S-S3C2-SA *1

Cable : AWG22 lose line 3m

Loose cable AWG22 3m

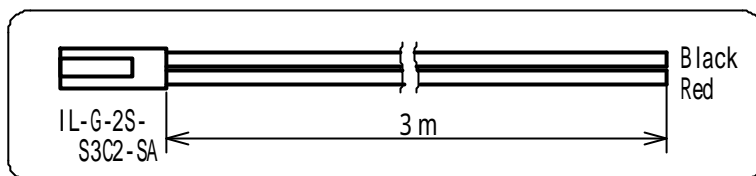

- CN2 : Motor cable

Model number : OMC-IL6P3

Connector : IL-G-6S-S3C2-SA *1

Cable : AWG22 lose line 3m

Loose cable AWG22 3m

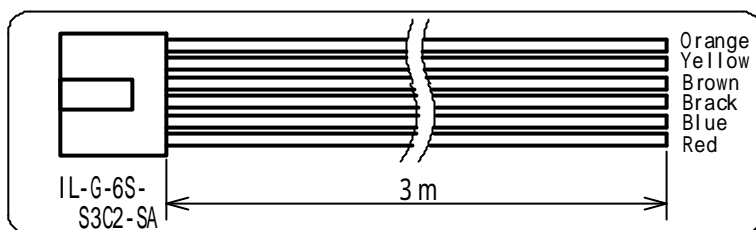

- CN3 : Pulse cable

Model number : OSC-IL4P3

Connector : IL-G-4S-S3C2-SA *1

Cable : AWG24 shield line 3m

Twisted pare cable AWG24 3m

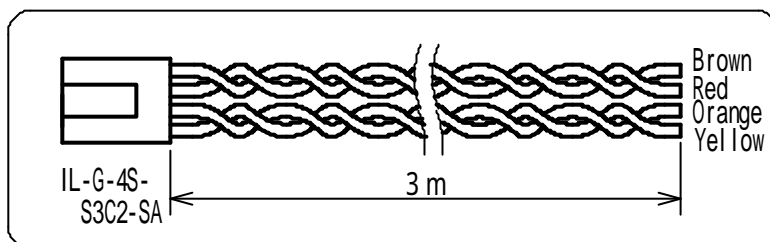

*1= J.A.E brand housing (Contact, IL-G-C2-SC-10000 is used)

• Bracket

Model number; SND100-OPM-01

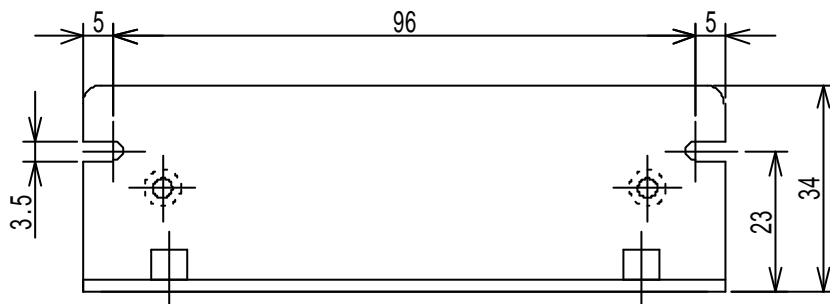
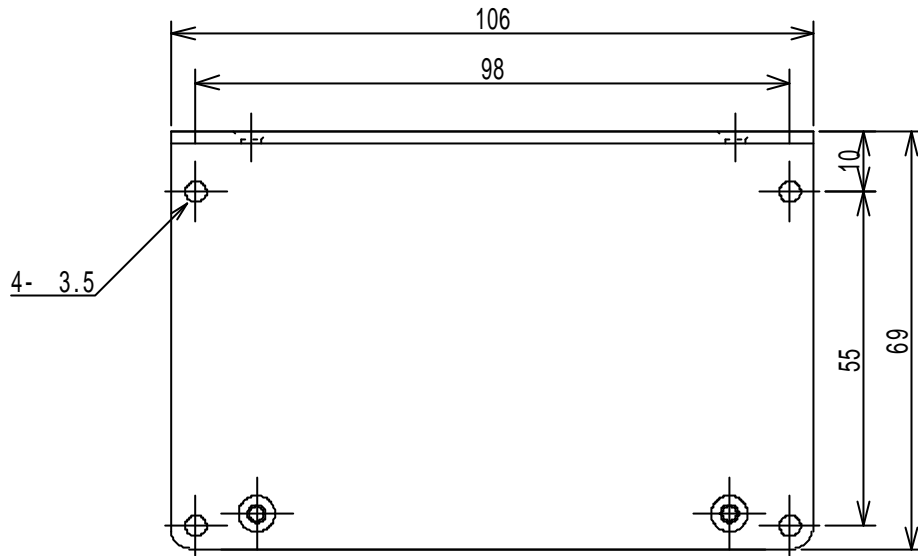

Please understand that we may make modifications to our products without notification in order to improve the capabilities and external appearance of our products.

MYCOM

MYCOM, INC. (Head office)

12, S. Shimobano, Saga hirosawa, Ukyo, Kyoto, Japan 616-8303

TEL: 81-75-882-3601

FAX : 81-75-882-6531

Home Page : <http://www.mycom-japan.co.jp/>

NYDEN CORP.

2610, North First St. #B San Jose, Ca, 95134, USA

TEL: 1-408-232-7700

Home Page: <http://www.nyden.com>

MYCOM TECHNOLOGY, INC.

2Fl., No.333, Fuhsing N, Road Taipei, Taiwan, R.O.C.

TEL : 886-2-2719-0525

MYCOM KOREA, INC.

Rm.301, Keum Chang Bldg. #328-1, 6Ka, Dangsang-Dong Yeoung Dungpo-ku Seoul,
Korea

TEL : 82-2-2635-6703

MYCOM THCHNOLOGY (SINGAPORE) PTE. LTD.

No.1, Sims Lane #05-05, One Sims Lane, Singapore 387355

TEL : 65-6743-4476

Home Page : <http://www.mycommts.com.sg>

Malaysian Contact;

No.1E-12-07, Jalan Batu Uban, Sunny Ville, Penang, Malaysia

TEL : 60-04-656-0328