

READ AND SAVE THESE INSTRUCTIONS

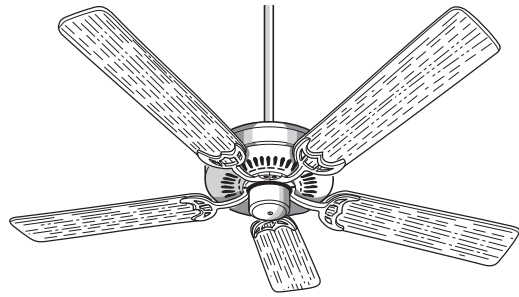

DESIGNER REMOTE Series Ceiling Fan Owner's Manual

Net Weight: 17.3 Lbs.



Model No.

CF759OB00 CF759PB00
CF759TG00 CF759HTW00
CF759BS00 CF759AB00
CF759WW00

LIMITED WARRANTY

What The Warranty Covers:

This warranty covers the motor and the other components and accessories of your Emerson ceiling fan against all defects in workmanship and materials. You must be the original purchaser or user of the product to be covered.

What The Period Of Coverage Is:

As it applies to the motor, this warranty will last for thirty years from the date you purchased your ceiling fan. All other components and accessories are covered by this warranty for one year from the date you purchased your ceiling fan. ANY IMPLIED WARRANTY OF MERCHANTABILITY OR FITNESS FOR A PARTICULAR PURPOSE, MADE WITH RESPECT TO COMPONENTS AND ACCESSORIES IS ALSO LIMITED TO ONE YEAR.

What Will Emerson Company Do To Correct Problems:

Emerson Company will replace a defective Emerson Air Comfort Ceiling Fan motor, blade, component or other accessory at no charge to you. If repair of the motor or blades is not practical or possible within a reasonable time and no replacement can be provided, Emerson Company will refund the actual purchase price of your fan. We will ship the repaired product or replacement to you at no charge, but you are responsible for all costs or removal, reinstallation and shipping of the product to Emerson Electric.

How Can You Get Service:

YOU MUST HAVE PROOF OF YOUR PURCHASE OF THE CEILING FAN TO OBTAIN LIMITED WARRANTY SERVICE. KEEP YOUR RECEIPT OR OTHER PROOF OF PURCHASE. You can return the product to our factory or to your nearest authorized service center.

- To return the product to the factory, obtain a return authorization and service identification tag by writing to Air Comfort Products, Division of Emerson Company, 8100 W. Florissant Ave., St. Louis, MO 63136. Include all model numbers shown on the product with your request.
- To return the product to an authorized service center, call 1-800-654-3545 for the address of the nearest authorized service center.

You will be responsible for all insurance, freight or other transportation charges to our factory or authorized service center. Your Emerson Air Comfort Ceiling Fan should be properly packed to avoid damage in transit since we will not be responsible for any such damage.

What Is Not Covered:

The glass globes and light bulbs of your ceiling fan are not covered by this warranty. This warranty also does not cover any defects, malfunctions or failures caused by:

- Repairs by persons not authorized by Emerson Company,
- Use of parts or accessories not authorized by Emerson Company,
- Mishandling, improper installation, modifications or damage to your ceiling fan while in your possession, or
- Unreasonable use, misuse, abuse, including failing to do reasonable and necessary maintenance, and normal wear and tear.

Additionally, this warranty and any implied warranty of merchantability or fitness for a particular purpose are voided when:

- The original purchaser or user ceases to own the product, or
- The fan is moved from its original point of installation.

This warranty is only valid within the 50 states of the United States and the District of Columbia. No other written or oral warranties apply, and no employee, agent, dealer or other person is authorized to give any warranties on behalf of Emerson Company.

REPAIR, REPLACEMENT OR A REFUND ARE THE EXCLUSIVE REMEDIES AVAILABLE UNDER THIS WARRANTY AND EMERSON IS NOT RESPONSIBLE FOR DAMAGES OF ANY KIND, INCLUDING INCIDENTAL AND CONSEQUENTIAL DAMAGES. Incidental damages include but are not limited to such damages as loss of time and loss of use. Consequential damages include but are not limited to the cost of repairing or replacing other property which was damaged if this product does not work properly.

How State Law Relates To The Warranty:

Some states do not allow the exclusion or limitation of incidental or consequential damages so the above exclusion or limitation may not apply to you. This warranty gives you specific legal rights, and you may also have other rights which vary from state to state.

 **WARNING**

WARNING: To avoid fire, shock, and serious personal injury, follow these instructions.

Safety Instructions

1. Read your owner's manual carefully and keep it for future reference.
2. Before servicing or cleaning unit, switch power off at service panel and lock service panel disconnecting means to prevent power from being switched on accidentally. When the service disconnecting means cannot be locked, securely fasten a warning device, such as a tag, to the service panel.
3. Be careful of the fan and blades when cleaning, painting, or working near the fan. Always turn off the power to the ceiling fan before servicing.
4. Do not put anything into the fan blades while they are turning.
5. Do not operate reversing switch until fan blades have come to a complete stop.

Additional Safety Instructions for Installation

1. To avoid possible shock, be sure electricity is turned off at the fuse box before wiring, and do not operate fan without blades.
2. All wiring must satisfy National and Local Electrical Codes. Use the National Electrical Code if Local Codes do not exist. The ceiling fan must be grounded as a precaution against possible electrical shock. Electrical installation should be made or approved by a licensed electrician.
3. The outlet box and joist must be securely mounted and capable of reliably supporting at least 50 pounds. Use only U.L. outlet boxes listed as acceptable for fan support, and use the mounting screws provided with the outlet box. Most outlet boxes commonly used for support of light fixtures are not acceptable for fan support and may need to be replaced. Consult a qualified electrician if in doubt.
4. The downrod furnished with the fan proves the minimum recommended floor to fan blade clearance for an 8 foot ceiling.
5. The fan must be mounted with the fan blades at least 7 feet from the floor to prevent accidental contact with the fan blades.
6. Follow the recommended instructions for the proper method of wiring your ceiling fan. If you do not know enough about electrical wiring, have your fan installed by a licensed electrician.

WARNING: To avoid fire, shock or injury, do not use an Emerson or any other brand of control not specifically approved for this fan.

WARNING: This product is designed to use only those parts supplied with this product and/or any accessories designated specifically for use this product by Emerson. Substitution of parts or accessories not designated for use with this product by Emerson could result in personal injury or property damage.

WARNING: To Reduce the risk of personal injury, do not bend the blade flange when installing the blade flanges, balancing the blades or cleaning the fan. Do not insert foreign objects in between rotating fan blades.

DATE CODE: _____

The date code of this fan may be found on the box, stamped in ink on a white label.

You should record this data above and keep it in a safe place for future use.

This Manual Is Designed to Make it as Easy as Possible for You to Assemble, Install, Operate and Maintain Your Ceiling Fan

Tools Needed for Assembly

One Phillips head screwdriver
One 1/4" blade screwdriver
Three wire connectors (supplied).

One stepladder
One wire stripper

Installed Wire Length
Up to 50 ft.
50-100 ft.

Wire Size A.W.G.
14
12

MATERIALS

Wiring outlet box and box connectors must be of type required by the local code. The minimum would be a 3-conductor (2-wire with ground) of size shown to the right:

⚠ WARNING

Before assembly your ceiling fan, refer to section on proper method of wiring your fan (page 6). If you feel you do not have enough wiring knowledge or experience, have your fan installed by a licensed electrician.

Unpacking Instructions

For your convenience, check-off boxes are provided next to each step. As each step is completed, place a check mark in the box. This will insure that all steps have been completed and will be helpful in finding your place should you be interrupted.

⚠ WARNING

Do not install or use fan if any part is damaged or missing. Call Toll-Free:

1-800-654-3545

⚠ WARNING

This product is designed to use only those parts supplied with this product and/or any accessories designated specifically for use with this product by Emerson Company. Substitution of parts or accessories not designated for use with this product by Emerson Company could result in personal injury or property damage.

NOTE: Place the parts from the loose parts bags in a small container to keep them from being lost. If any parts are missing, contact your local retailer or catalog outlet for replacement before proceeding.

2. Remove the fan assembly from the protective plastic bag. Place the fan assembly into the upper foam pad with the bottom of the motor facing up.

The upper foam pad serves as a holder for the fan during the first stages of assembly.

1. Check to see that you have received the following parts:

NOTE: If you are uncertain of part description, refer to exploded view illustration.

- Fan motor assembly
- One switch housing assembly with receiver
- One hand held transmitter
- Five fan blades
- One ceiling cover
- Five blade flanges
- One hanger ball/downrod assembly
- One hanger bracket
- One coupling cover
- One loose parts bag containing:
 - Sixteen 3/16-24 x 5/16" slotted Phillips blade screws
 - Sixteen blade washers
 - Eleven 1/4-20 x 1/2" Phillips oval head flange screws
 - Three wire connectors
 - Two threaded studs
 - Two knurled knobs
 - Two lockwashers
 - One clevis pin
 - One hairpin clip

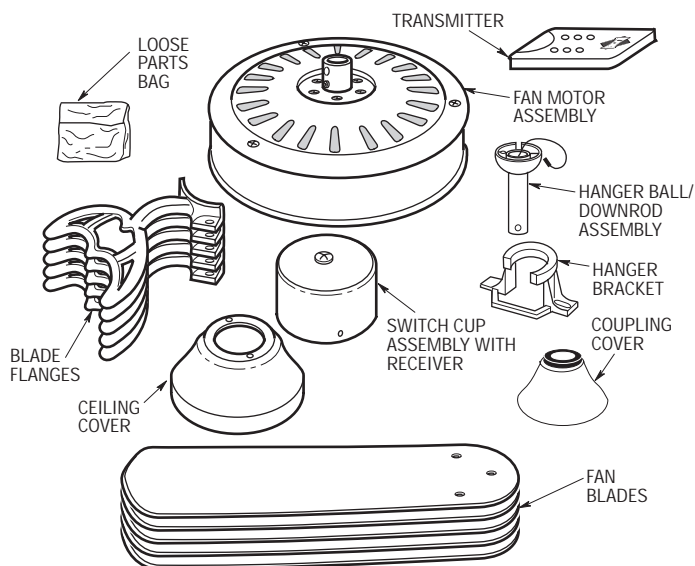

How to Put Your Ceiling Fan Together

1. Remove the hanger ball by loosening the setscrew in the hanger ball until the ball falls freely down the downrod (Figure 1). Remove the pin from the downrod, then remove the hanger ball. Retain the pin and hanger ball for reinstallation in step 5.

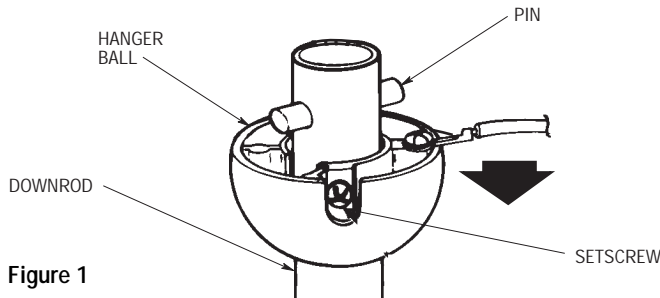



Figure 1

2. Separate, untwist and unkink the three 80" motor leads. Route the motor lead wires through the downrod. Remove the upper setscrew from the motor coupling. Align the clevis pin holes in the downrod with the holes in the motor coupling. Install the clevis pin and secure with the hairpin clip (Figure 2). The clevis pin must go through the holes in the motor coupling and the holes in the downrod. Be sure to push the straight leg of the hairpin clip through the hole near the end of the clevis pin until the curved portion of the hairpin clip snaps around the clevis pin. The hairpin clip must be properly installed to prevent the clevis pin from working loose. Pull on the downrod to make sure the clevis pin is properly installed. Reinstall the upper setscrew in the motor coupling. Check that the lower setscrew is tightened securely (Figure 2).

NOTE: The setscrews must be properly installed as described above, or fan wobble could result.

 WARNING
<p>It is critical that the clevis pin in the motor coupling is properly installed and the setscrews securely tightened. Failure to verify that the pin and setscrews are properly installed could result in the fan falling.</p>

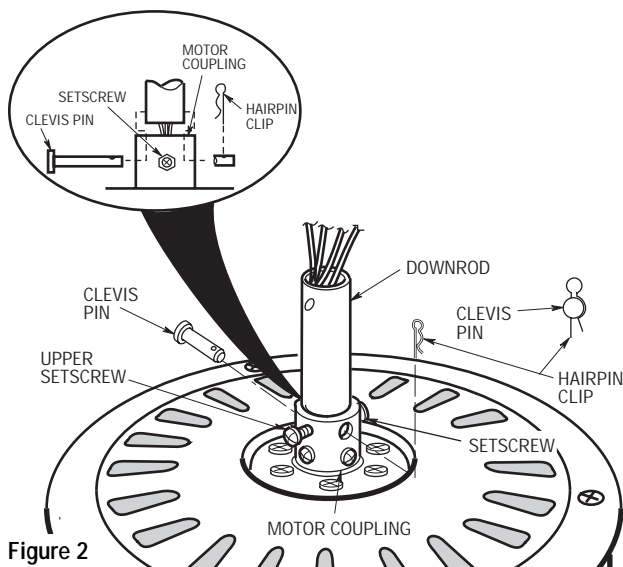

Figure 2

3. Make sure the grommet is properly installed in the coupling cover, then slide the coupling cover on the downrod until it rests on the motor housing. Place the ceiling cover over the downrod. Be sure that the ceiling cover and the coupling cover are both oriented correctly (Figure 3).

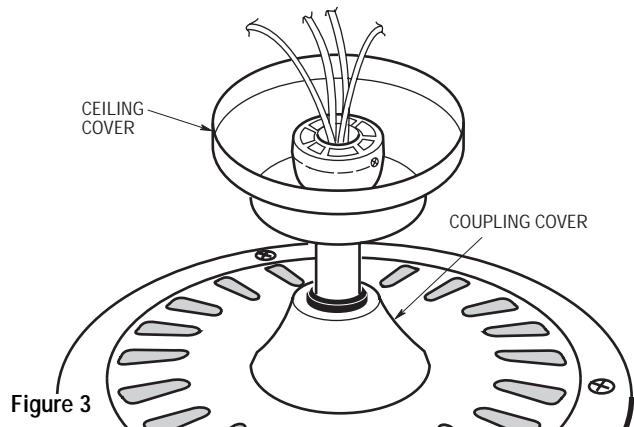



Figure 3

4. Reinstall the hanger ball (Figure 4) on the downrod as follows. Route the three 80" motor leads through the hanger ball. Position the pin through the two holes in the downrod and align the hanger ball so the pin is captured in the groove in the top of the hanger ball. Pull the hanger ball up tight against the pin and securely tighten the setscrew in the hanger ball. A loose setscrew could create fan wobble.

 WARNING
<p>It is critical that the pin in the hanger ball is properly installed and the setscrew securely tightened. Failure to verify that the pin and setscrew are properly installed could result in the fan falling.</p>

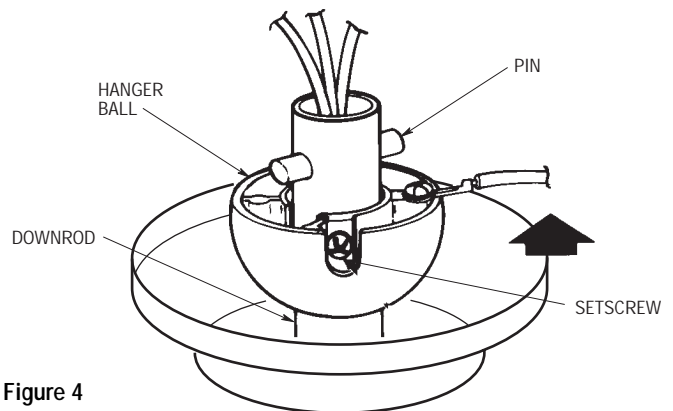

Figure 4

5. The fan comes with blue, black and white leads that are 80" long. Before installing fan, measure up approximately 6 to 9-inches above top of hanger ball/downrod assembly. Cut off excess leads and strip back insulation 1/2-inch from end of leads.
6. Engage the connector of the switch housing assembly with the motor connector (Figure 5). The two connectors are keyed and color-coded and must be mated correctly (color-to-color) before they can be engaged. Make sure the connector latch closes properly.

- 7. Remove the three switch housing mounting screws (Figure 5) from the switch housing plate. Position the switch housing assembly on the switch housing plate and align the holes in the switch housing assembly with the holes in the plate. Secure the switch housing assembly by installing the three screws (Figure 6).

▲ WARNING

To avoid possible fire or shock, do not pinch wires between the switch cup assembly and the switch cup plate.

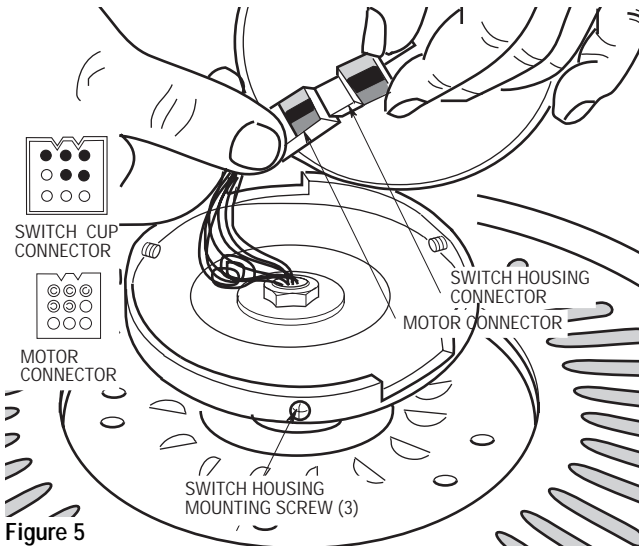

Figure 5

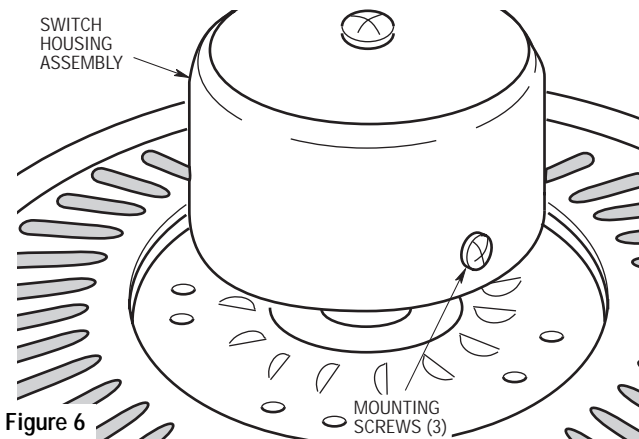

Figure 6

- 8. Turn fan assembly upside down in preparation for mounting fan blade assemblies.
- 9. Mount blade flanges to fan blades using three 3/16-24 x 5/16" slotted Phillips blade screws and three blade washers (Figure 7).

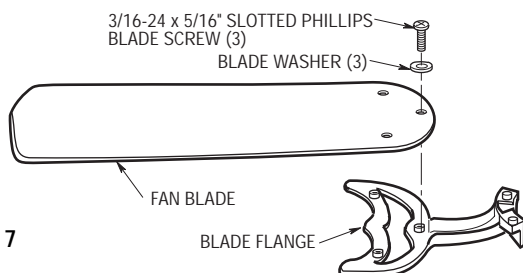

Figure 7

NOTE: Take care not to scratch fan housing when installing blades.

NOTE: Remove and discard the four shipping spacers and screws from the motor hub.

- 10. Loosely attach one blade assembly to the motor hub using two 1/4-20 x 1/2" Phillips oval head flange screws. Make sure the screws are **NOT** tightened. (Figure 8.) Repeat this procedure for other four blade assemblies.

▲ WARNING

To reduce the risk of personal injury, do not bend the blade flange when installing the blade flanges, balancing the blades or cleaning the fan. Do not insert foreign objects in between rotating fan blades.

- 11. The blade flanges have an interlocking feature that must be fully engaged before tightening the screw. Make sure all the flanges are properly engaged and then tighten the flange screws. If one of the flanges does not seat properly on the motor hub, loosen the adjacent flange screws, re-engage and reseat the flanges, then tighten the screws again.

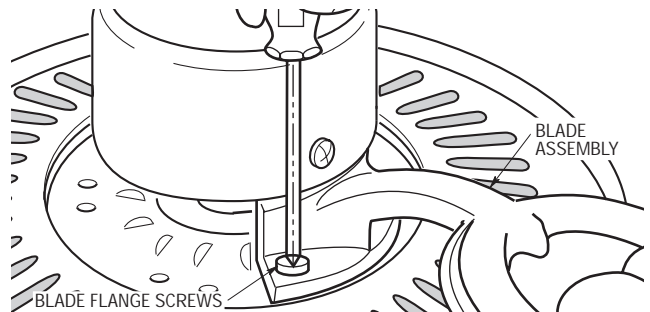

Figure 8

- 12. You have now completed the assembly of your new ceiling fan. You can now proceed with hanging and wiring your fan.

Electrical Requirements

Your new ceiling fan will require a grounded electrical supply line of 120 volts AC, 60 Hz, 15 amp circuit.

The outlet box must be securely anchored and capable of withstanding a load of at least 50 pounds.

▲ WARNING

To reduce the risk of fire, electric shock, or personal injury, mount fan to outlet box marked acceptable for fan support, and use screws supplied with outlet box. Most outlet boxes commonly used for support of light fixtures are not acceptable for fan support and may need to be replaced. Consult a qualified electrician if in doubt.

If your fan is to replace an existing ceiling light fixture, turn electricity off at the main fuse box at this time and remove the existing light fixture.

▲ WARNING

Turning off wall switch is not sufficient. To avoid possible electrical shock, be sure electricity is turned off at the main fuse box before wiring. All wiring must be in accordance with National and Local codes and the ceiling fan must be properly grounded as a precaution against possible electrical shock.

⚠ WARNING

To avoid fire or shock, follow all wiring instructions carefully.
Any electrical work not described in these instructions should be done or approved by a licensed electrician.

How to Hang Your Ceiling Fan

⚠ WARNING

The fan must be hung with at least 7' of clearance from floor to blades (Figure 9).

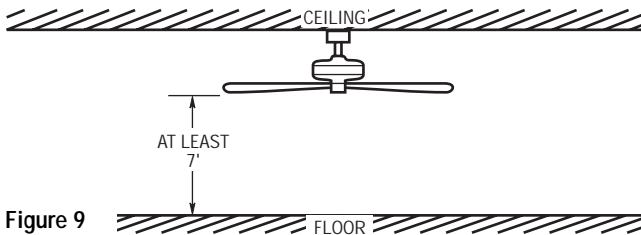

Figure 9

⚠ WARNING

The outlet box must be securely anchored and capable of withstanding a load of at least 50 lbs.

⚠ WARNING

To reduce the risk of fire, electric shock, or personal injury, mount fan to outlet box marked acceptable for fan support, and use screws supplied with outlet box. Most outlet boxes commonly used for support of light fixtures are not acceptable for fan support and may need to be replaced. Consult a qualified electrician in in doubt.

- 1. Securely attach the hanger bracket to the outlet box using the two screws supplied with the outlet box. (Figure 10.)

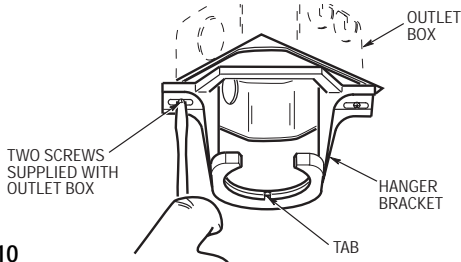

Figure 10

- 2. Carefully lift the fan and seat the hanger ball/downrod assembly on the hanger bracket that was just attached to the outlet box (Figure 11). Be sure the groove in the ball is lined up with tab on the hanger bracket (Figure 10).

⚠ WARNING

Hanger bracket must seat firmly against outlet box. If the outlet box is recessed, remove wall board until bracket contacts box. If bracket and/or outlet box are not securely attached, the fan could wobble or fall.

⚠ WARNING

Failure to seat tab in groove could cause damage to electrical wires and possible shock or fire hazard.

NOTE: CEILING COVER, SUPPLY WIRES AND FAN WIRES OMITTED FOR CLARITY.

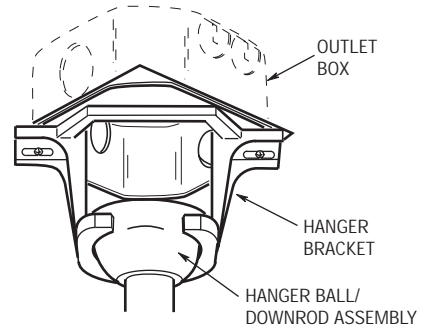

Figure 11

⚠ WARNING

To avoid possible fire or shock, do not pinch wires between the hanger ball/downrod assembly and hanger bracket.

How to Wire Your Ceiling Fan

If you feel that you do not have enough electrical wiring knowledge or experience, have your fan installed by a licensed electrician.

⚠ WARNING

To avoid possible electrical shock, be sure electricity is turned off at the main fuse box before wiring.
NOTE: If you are not sure if the outlet box is grounded, contact a licensed electrician for advice, as it must be grounded for safe operation.

- 1. Connect the green grounding lead from the hanger ball and the green grounding lead from the hanger bracket to the grounding conductor of supply (this may be a bare wire or wire with green colored insulation). Securely connect wires with wire connector supplied (Figure 12).

NOTE: If you are using an Emerson Light Fixture with your fan, refer to Light Fixture Owner's Manual for wiring.

- 2. Securely connect the fan motor white wire to the supply white (neutral) wire using wire connector supplied (Figure 12). Securely connect the fan motor black wire and blue wire to the supply black (hot) wire using wire connector supplied (Figure 12). After connections have been made, turn leads upward and carefully push leads into the outlet box, with the white and green leads on one side of the outlet box and the black and blue leads on the other side of the outlet box.

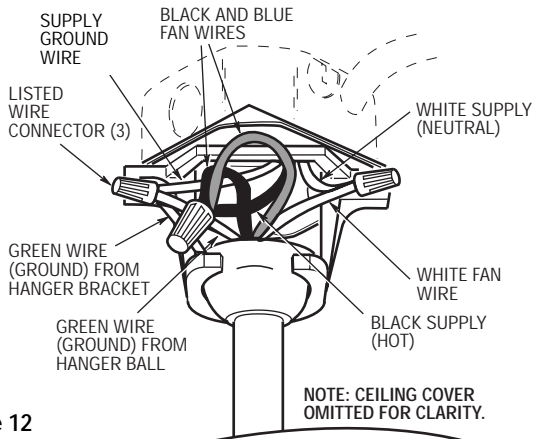

Figure 12

▲ WARNING

Check to see that all connections are tight, including ground, and that no bare wire is visible at the wire connectors, except for the ground wire. Do not operate fan until blades are in place. Noise and fan damage could result.

- 3. Screw the two threaded studs (supplied) into the tapped holes in the hanger bracket.
- 4. Lift the ceiling cover up to the threaded studs and turn until studs protrude through the holes in the ceiling cover (Figure 13).
- 5. Secure the ceiling cover in place by sliding lockwashers over the threaded studs and installing the two knurled knobs (supplied). (Figure 13). Tighten the knurled knobs securely until the ceiling cover fits snugly against the ceiling and the hole in the ceiling cover is clear of the downrod. Your fan is now wired to be turned on and off from the fan switch.

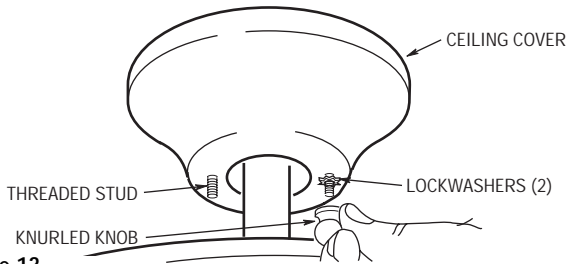

Figure 13

▲ WARNING

To avoid possible fire or shock, make sure that the electrical wires are completely inside the outlet box and not pinched between the ceiling cover and the ceiling.

Setting Remote Control Operating Frequency

Your Emerson Remote Control Fan receiver and transmitter can be set to operate at one of 16 different frequencies. In most cases you will not need to change the factory set frequency. The frequency should only need to be changed for one of the following reasons:

- a. Multiple fans in one location that you wish to operate from one transmitter. (ALL fans should be set at the same frequency.)

NOTE: Your Emerson Remote Control is designed to operate from a distance up to 20 feet from the fan. If you are operating multiple fans with one transmitter you should be no more than 20 feet from any of the fans to ensure that all fans will respond at the same time.

- b. Multiple fans in one location that you wish to operate from different transmitters. (ALL fans set to different frequencies.)
- c. Interference with other household systems such as your garage door opener.

NOTE: If you change the operating frequency, you must change both the transmitter and receiver to the same frequency. The remote control will not operate unless both the transmitter and receiver are set at the same frequency.

Setting Transmitter Frequency

- 1. Remove battery cover and the battery from the transmitter. Locate the switch with four levers numbered 1, 2, 3, 4, just above the battery compartment (See Figure 14).
- 2. With a narrow blade screwdriver, change the position of one or more of the four levers on the switch. Note the positions of each of the four levers by number; down is ON, up is OFF.

Setting Receiver Frequency

- 1. After electricity has been turned off at the main fuse box, remove the switch housing assembly by removing the three mounting screws (See Figure 6).
- 2. Disconnect the switch housing connector from the motor connector by squeezing the latch and pulling the connectors apart.
- 3. Remove the receiver from the switch housing and locate the switch with four numbered levers (same as transmitter). (See Figures 14 and 15).
- 4. Set the position of all four levers, ON or OFF to the same position as those on the transmitter.
- 5. Install the receiver in the switch housing, push the motor connector into the switch housing connector and assemble the switch housing assembly to the housing plate (See Figures 5 and 6).

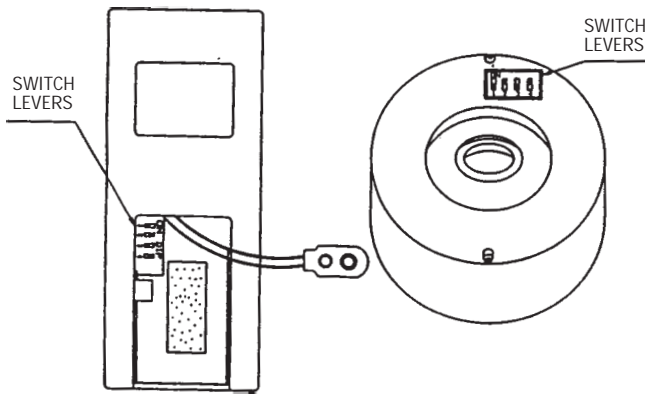

Figure 14. TRANSMITTER

Figure 15. RECEIVER

Operation of Your Remote Control

1. To set the desired fan speed, push the HI, MED or LOW buttons to set your fan on high, medium or low speed. (See Figure 17).
2. To reverse the direction the fan is turning, press the FOR/REV button. The direction the fan turns will change each time the FOR/REV button is pressed.
3. To turn the fan OFF press the FAN/OFF button.
4. To set the level of light brightness, press and hold the LIGHT DIMMER button. The light brightness will continue to increase then decrease while the button is held down. When the light is at the desired brightness, release the button.
5. To turn the light ON or OFF, press and release the LIGHT DIMMER button. The light will turn ON at the light level previously set (See Step 4).

Red light turns on when any button is pressed. If the light does not come on, replace your battery.

Using Your Ceiling Fan

1. Restore electrical power to the outlet box by turning the electricity on at the main fuse box.
2. Remove the battery cover by pressing firmly on the arrow and sliding the cover off the control transmitter.
3. Engage the connector in the transmitter with the terminals of a 9-volt alkaline battery (not supplied) (Figure 16).
4. Position the battery in the transmitter and replace the battery cover.
5. Operate ceiling fan using the Remote Control transmitter.

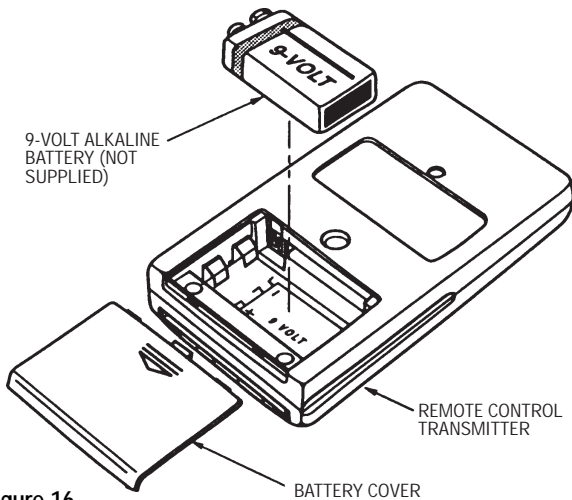

Figure 16

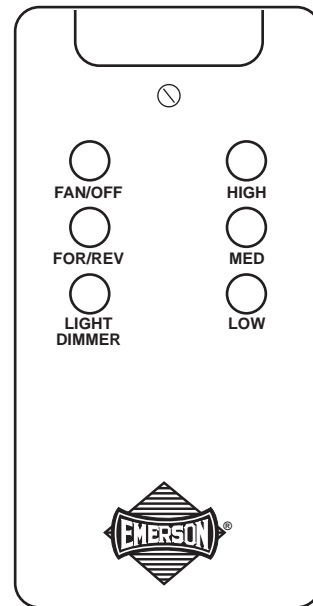

Figure 17

Maintenance

IMPORTANT CARE INSTRUCTIONS for your Ceiling Fan

Periodic cleaning of your new ceiling fan is the only maintenance that is needed.

When cleaning, use only a soft brush or lint free cloth to avoid scratching the finish.

Abrasive cleaning agents are not required and should be avoided to prevent damage to finish.

 WARNING
<p>Do not use water when cleaning your ceiling fan. It could damage the motor or the blades and create the possibility of an electrical shock.</p>

Accessories

1. Ceiling Fan Light Kits (see store or catalog).
2. Downrod Kits (see store or catalog).

 WARNING
<p>The use of any other control not specifically approved for this fan could result in fire, shock and personal injury.</p>

 WARNING
<p>This product is designed to use only those parts supplied with this product and/or any accessories designated specifically for use with this product by Emerson Company. Substitution of parts or accessories not designated for use with this product by Emerson Company could result in personal injury or property damage.</p>

⚠ WARNING: FOR YOUR OWN SAFETY TURN OFF POWER AT FUSE BOX OR CIRCUIT BREAKER BEFORE TROUBLE SHOOTING YOUR FAN.

Trouble Shooting

TROUBLE	PROBABLE CAUSE	SUGGESTED REMEDY
1. Fan will not start.	<ol style="list-style-type: none"> 1. Fuse or circuit breaker blown. 2. Loose power line connections to the fan, or loose switch wire connections in the switch housing. 3. Reversing switch in neutral position. 	<ol style="list-style-type: none"> 1. Check main and branch circuit fuses or circuit breakers. 2. Check line wire connections to fan and switch wire connections in the switch housing. 3. Make sure reversing switch position is all the way to one side. <p>⚠ WARNING: Make sure main power is turned off.</p>
2. Fan sounds noisy.	<ol style="list-style-type: none"> 1. Blades not attached to fan. 2. Loose screws in motor housing. 3. Screws securing fan blade flanges to motor hub are loose. 4. Switch housing binding against blade hub. 5. Wire connectors inside switch housing rattling. 6. Motor noise caused by solid-state variable speed control. 7. Screws holding blades to flanges are loose. 	<ol style="list-style-type: none"> 1. Attach blades to fan before operating. 2. Check to make sure all screws in motor housing are snug (not over-tight). 3. Check to make sure the screws which attach the fan flanges to the motor hub are tight. 4. Check to make sure that the switch housing does not bind against the blade hub. 5. Check to make sure wire connectors in switch housing are not rattling against each other or against the interior wall of the switch housing. 6. Some fan motors are sensitive to signals from Solid-State variable speed controls. If Solid-State Control is used and motor noise results choose an alternative control method. 7. Tighten screws securely. <p>⚠ WARNING: Make sure main power is turned off.</p>
3. Fan wobbles excessively.	<ol style="list-style-type: none"> 1. Screws securing fan blade flanges to motor hub are loose. 2. Fan blade flanges not seated properly. 3. Hanger bracket and/or ceiling outlet box is not securely fastened. 4. Fan blades out of balance. 	<ol style="list-style-type: none"> 1. Check to be sure screws which attach the fan blade flanges to the motor hub are tight. 2. Check to be sure the fan blade flanges seat firmly and uniformly to the surface of the motor hub. If flanges are seated incorrectly, loosen the flange screws and retighten according to the procedure in the section on "How to Put Your Ceiling Fan Together". 3. Tighten the hanger bracket screws to the outlet box, and/or secure outlet box. 4. Interchanging an adjacent (side-by-side) blade pair can redistribute the weight and result in smoother operation.

Repair Parts Listing

Key No.	Description	Part Numbers						
		Model No. CF759AB00	Model No. CF759PB00	Model No. CF759OB00	Model No. CF759TG00	Model No. CF759BS00	Model No. CF759HTW00	Model No. CF759WW00
*	Hanger Ball Assembly, Consisting of:	760750	760750-1	760750-36	760750-37	760750-24	760750-34	760750-3
1	Hanger Bracket	—	—	—	—	—	—	—
2	Hanger Ball	—	—	—	—	—	—	—
3	Downrod	—	—	—	—	—	—	—
*	Parts Bag Containing:	761538-6	761538-5	761538-8	761538-8	761538-7	761538-5	761538-5
4	Wire Connector (3)	—	—	—	—	—	—	—
5	Pin, Clevis	—	—	—	—	—	—	—
6	Clip, Hairpin	—	—	—	—	—	—	—
7	Screw, 1/4-20 x 1/2" (11)	—	—	—	—	—	—	—
8	Screw, 3/16-24 x 5/16" (16)	—	—	—	—	—	—	—
9	Threaded Stud (2)	—	—	—	—	—	—	—
10	Lockwasher (2)	—	—	—	—	—	—	—
11	Knurled Knob (2)	—	—	—	—	—	—	—
12	Blade Washer (16)	—	—	—	—	—	—	—
13	Canopy, Ceiling	760169-2	760169-1	760169-24	760169-25	760169-15	760169-20	760169
14	Coupling Cover	761860-7	761860-10	761860-4	761860-1	761860-3	761860-5	761860
15	Control Transmitter	762023	762023	762023	762023	762023	762023	762023
16	Control Receiver	762036	762036	762036	762036	762036	762036	762036
17	Switch Housing	762024-3	762024-1	762024-4	762024-6	762024-5	762024-2	762024
18	Blade (set of 5)	761859-8	761859-8	761859-5	761859-16	761859-17	761859-6	761859-22
19	Flange (set of 5)	761901	761901-1	761901-4	761901-11	761901-9	761901-8	761901-5
—	Owner's Manual	BP7240-1	BP7240-1	BP7240-1	BP7240-1	BP7240-1	BP7240-1	BP7240-1

Before discarding packaging material, be certain all parts have been removed.

HOW TO ORDER REPAIR PARTS

WHEN ORDERING REPAIR PARTS, ALWAYS GIVE THE FOLLOWING INFORMATION:

- PART NUMBER
- PART DESCRIPTION
- NAME OF ITEM
- MODEL NUMBER

For repair parts, phone 1-800-654-3545.

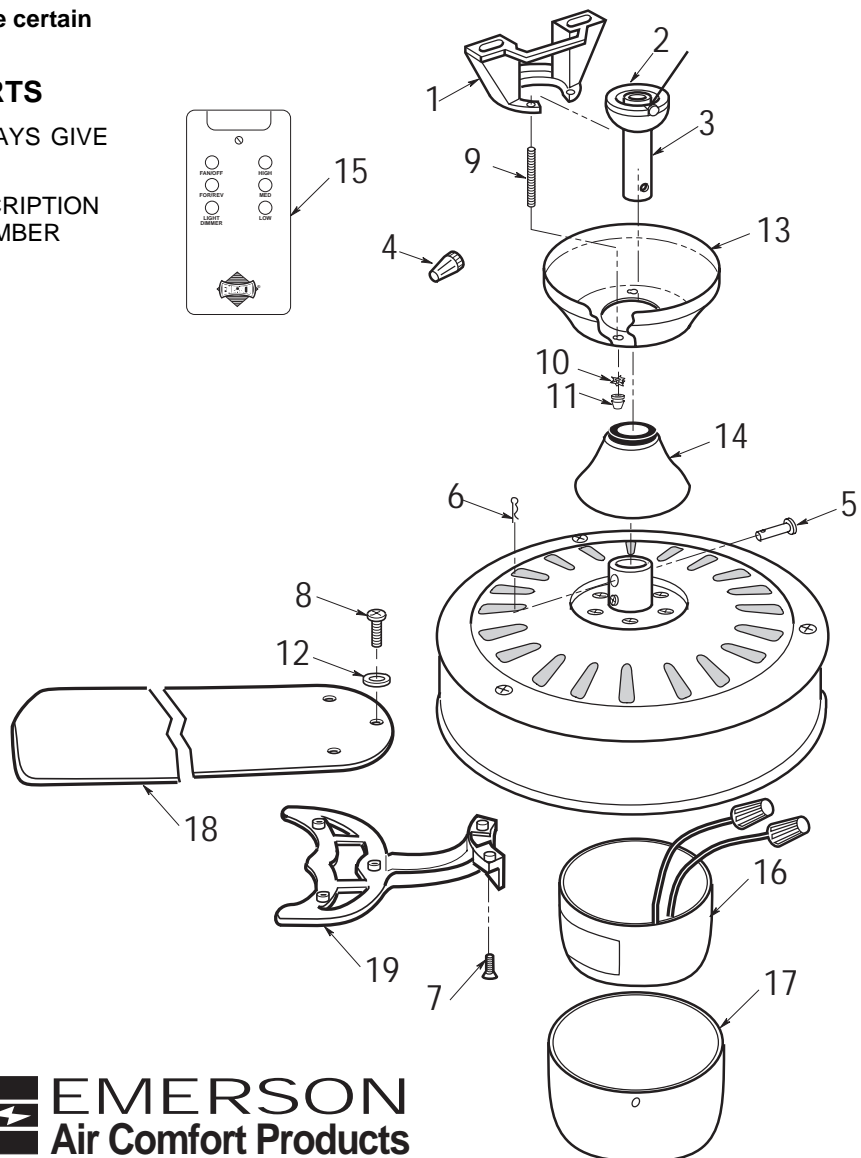

EMERSON
Air Comfort Products
 DIVISION OF EMERSON COMPANY
 8100 W. Florissant, St. Louis, MO 63136