



FLEXIT S4 X/TT - A4 X/TT S7 X/TT - A7 X/TT

E **User Manual**
Air Handling Unit
Cabinet Models with Heat Recovery



Contents

1	Important Safety Instructions	3
2	Method of Operation - System	3
3	Operation - Control	4
	3.1 Operation via a Kitchen Hood (A Models)	4
4	Troubleshooting	5
5	Cleaning - Maintenance	6
	5.1 Filters	6
	5.2 Other Maintenance	7
6	Overview Drawings	8
	6.1 Overview Drawing, S4 X/TT - A4 X/TT	8
	6.2 Overview Drawing, S7 X/TT - A7 X/TT	8
7	Technical Data	9
	7.1 Technical Data, S4 X/TT - A4 X/TT	9
	7.2 Technical Data, S7 X/TT - A7 X/TT	9
8	Dimensioned Drawings	10
9	Adjusting the Unit	11
	9.1 Adjustment	11
	9.2 Control Card Adjustment Options	11
10	CE Declaration of Conformity	12

Symbols Used

This product has a number of symbols that are used to label the product itself and in the installation and user documentation. Here is an explanation of some of the commonest symbols.



Supply air

SUPPLY AIR



Extract air

EXTRACT AIR

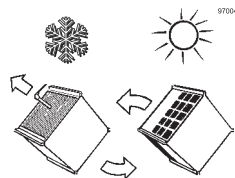

Normal Summer Cassette Option
EXCHANGER/SUMMER
CASSETTE

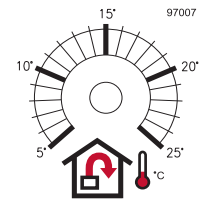

HEATING THERMOSTAT



DANGER! ELECTRICITY



DANGER! DO NOT TOUCH



Exhaust air

EXHAUST AIR



Outdoor air

OUTDOOR AIR

Symbols for units/electric heating



123

Normal speed

TRANSFORMER
ADJUSTMENT
SUPPLY AIR
STAGE 2



123

Normal speed

TRANSFORMER
ADJUSTMENT
EXTRACT AIR
STAGE 2

*Our products are subject to continuous development and we therefore reserve the right to make changes.
We also disclaim liability for any printing errors that may occur.*

1 Important Safety Instructions



To reduce the risk of fire, electric shock or injury, read all the safety instructions and warning texts before using the unit.

- This unit is only designed to handle ventilation air in buildings.
- It must not be used to extract combustibles or flammable gases.
- Remove the power plug before commencing any service and maintenance work.
- Before you open the door, the unit must be dead and the fans must be given time to stop (min. 2 minutes).
- The unit contains heating elements that must not be touched when they are hot.
- The unit must not be operated without the filters being in place.
- Follow the user manual precisely.



To maintain a good indoor climate, comply with regulations and avoid condensation damage, the unit must never be stopped apart from during service/maintenance or in connection with an accident.

All descriptions of Flexit S4 and S7 in this manual also apply to the A models, except where specified otherwise.

2. Functional Description

In the heat exchanger cassette **HR-X**, the cold outdoor air and the warm extract air “cross” each other without coming into direct contact with each other. With this principle, 60-70% of the heat in the extract air will be transferred to the supply air. In addition, a thermostat-controlled heating element **EB1** will ensure that the supply air has the desired temperature. This supply air is passed via ducts and valves to living rooms and bedrooms. The extract air is extracted either from the same room or via door gaps/overflow gratings to toilets and wet rooms. The used air is passed via a duct system back to the unit, emits heat as stated above and is blown out of the building via a roof hat or wall grating.

Heating Elements

The heating elements are protected against overheating by overheating thermostats **F20/F21**, which switch off at 65°C. As an additional safety measure, overheating thermostats **F10/F11** switch off at 80°C. The overheating thermostats can be reset manually by pressing the white button. They are located at the front on the top of the unit. They are accessible by opening the doors and removing the plastic cover that covers the access opening. See the label. The RESET button is located on the innermost panel a little way inside the opening.



This is purely a ventilation system and not a heating system. The home must be heated in the normal manner. The heat gained from heat recovery must be seen in relation to a situation in which the extract air is blown right out of the home without recovery.

System Drawing

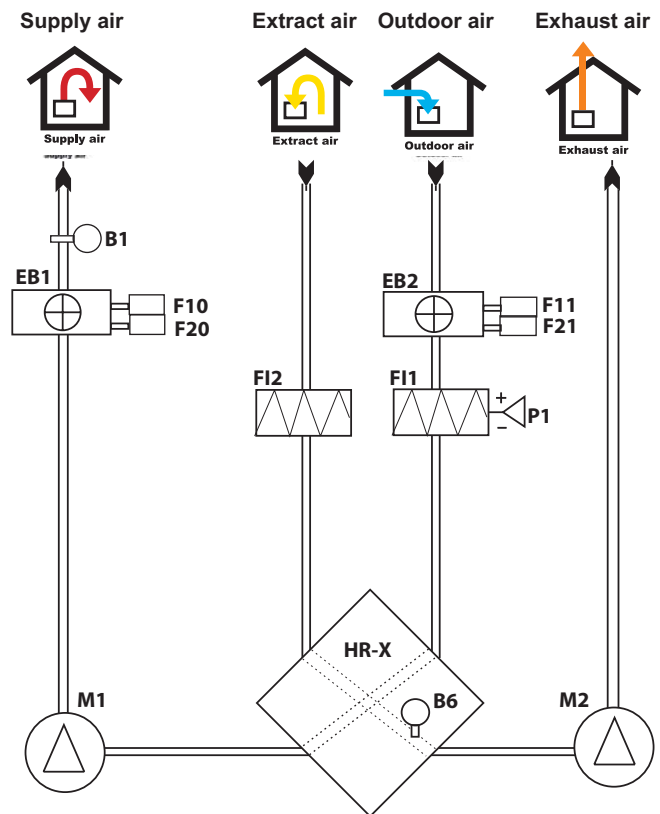

- B1 SUPPLY AIR TEMPERATURE SENSOR
 - B6 THERMOGUARD
 - F1, F2 OVERHEATING THERMOSTATS
 - F20, F21 OVERHEATING THERMOSTATS
 - F11 SUPPLY AIR FILTER
 - F12 EXTRACT AIR FILTER
 - EB1 HEATING ELEMENT
 - EB2 PREHEATING ELEMENT
 - HR-X HEAT EXCHANGER CASSETTE
 - M1 SUPPLY AIR FAN
 - M2 EXTRACT AIR FAN
 - P1 PRESSURE GUARD (ACCESSORY)
- * The following applies to the A models:
 K KITCHEN HOOD
 DA4 DAMPER - KITCHEN HOOD

Frost Protection

The unit is fitted with a special thermoguard for maximum utilisation of the heat recovery function and maintenance of balanced ventilation.

The thermoguard has a sensor rod B6 with a dual function. This is located in the exchanger cassette’s extract air duct and has an NTC element to check the temperature and an indicator to register condensation water.

If the extract air is dry, the thermoguard will ensure that the unit works normally down to an outdoor temperature of approximately -15°C. At lower temperatures, it will produce an impulse to activate the frost protection function. This function will be repeated periodically until the exchanger cassette’s temperature is sufficient to prevent freezing. If the extract air is damp, this function will start at an outdoor temperature of approximately -8°C. The frost protection function operates as follows:

- The preheating element **EB2** is activated.
- When this does not produce sufficient frost protection, the speed of the supply air fan **M1** is reduced.

3 Operation - Control

The speed of the fans in the unit is controlled from a separately mounted SP 30 control switch. On model S4, this is located at the bottom of the unit. Depending on the operating situation, the fan speed is set to the desired level.

- MIN stage:** Used when not as much ventilation as normal is required.
- NORMAL stage:** Normal operating ventilation. This is the position for daily operation.
- MAX stage:** Used when increased ventilation is required in wet rooms or throughout the flat. Must be used during and for a while after showering and clothes drying, for example, to avoid condensation in the ducts.

SP 30 Control Switch for Electronic Automatic Control with a Thermoguard

This contains the following functions:

- Right pressure switch (fan symbol) to choose between min, normal and max speeds with an indicator lamp to show which speed stage is active.
- Left pressure switch (+ symbol) to choose heating OFF/ON. This switch is used to switch heating off/on (disconnected during the warm part of the year). The heating thermostat (item 4/Chap. 6 General Drawings) is factory-set to 20°C in the unit. It is located inside the heating adjustment (item 4/page 8) and should not be set to over 25°C. It can be adjusted with a flat screwdriver. The sensor for the thermostat is located in the supply air duct. Some heat loss up to the valves must be expected where ducts pass through a cold environment.

- Red lamp (!): Slow flash: Filter must be replaced (provided that a pressure guard is installed).
Fast flash: Overheating thermostat triggered or thermoguard not connected.
Permanently on: Both errors
- Green lamp (+): This lights when the heating switch is in the ON position:
- Yellow lamp (°C): This lights when the heating is active (the element is heating).

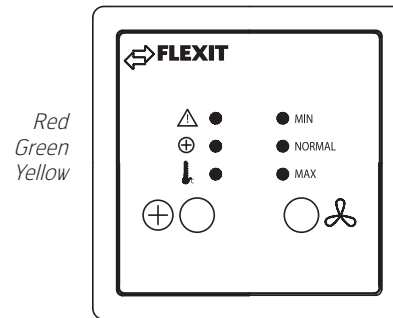

Red
Green
Yellow

If the unit is in temporary automatic frost protection mode in the winter, the unit will not react to a change in speed before the frost protection function has ceased.



If there is a power cut, the unit will automatically be set to the Normal level and active heating when it restarts. This means that the heating element will provide heat if needed.

3.1 Operation via a Kitchen Hood (A Models)

Figure 1:

A – Knob for damper/timer

B – Pushbutton for light

Open the damper when preparing food. The damper closes automatically after a maximum of 60 minutes or if you turn the damper knob to  as shown in Figure 1. When the timer is activated, the air handling unit is forced in addition to the damper function.

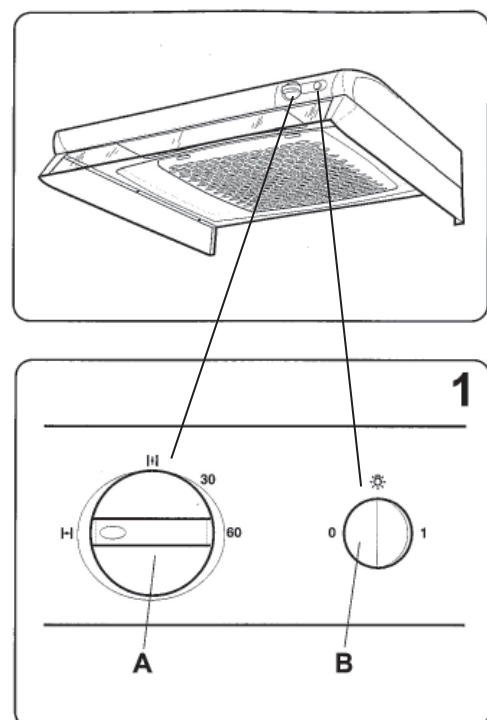

4 Troubleshooting

FAULT	DO THE FOLLOWING
If the fans are not working or cannot be adjusted	<ul style="list-style-type: none"> • Check that the power plug is correctly inserted in the power point. • Check that the fuses in the electrical cabinet are switched on. • The fire thermostat(s) (item nos. 7, 8/ Chap. 6 General Drawings) may have been triggered. Remove the white plastic cover and press in the white reset button. • Check that the thermoguard (item no. 3) is connected.
If the supply air feels too cold	<ul style="list-style-type: none"> • Check that the heating switch is on and a summer cassette is not loaded. • The heating thermostat (item no. 4) can be set to a higher temperature. • Check that the thermoguard (item no. 3) is connected. • The fire thermostat(s) (item nos. 7, 8) may have been triggered. Remove the white plastic cover and press in the white reset button. • Check that the heating switch is activated
If the air flow rate has been seriously reduced	<ul style="list-style-type: none"> • The filters (item nos. 1, 2) may be clogged by dirt. Clean or replace them. See under "Cleaning - Maintenance". • The grille in the outdoor air cap may be clogged. See under "Cleaning - Maintenance".

If none of this helps, please contact your supplier for service. Please state the serial number on the rating plate inside the unit (open the door).

5 Cleaning - Maintenance



Before opening the door of the heat recovery system, switch off the heat, let the fans continue for three minutes to remove hot air, remove the power and wait 2 minutes before opening the doors.

5.1 Filters

Why change the filters?

Clean, filtered air is essential to ensure that your ventilation system contributes to a healthy indoor environment. Therefore, the unit is fitted with replaceable filters. It is very important to change them when they are dirty. Otherwise, the system may be damaged.

When should the filters be changed?

In general, the filters need to be changed once a year, preferably in the autumn (after the pollen season). In areas with a lot of dust and contamination, the filters should be changed in the spring and autumn.

*Cabinet model filter location
(the drawing shows the left
model/the right model is
inverted)*

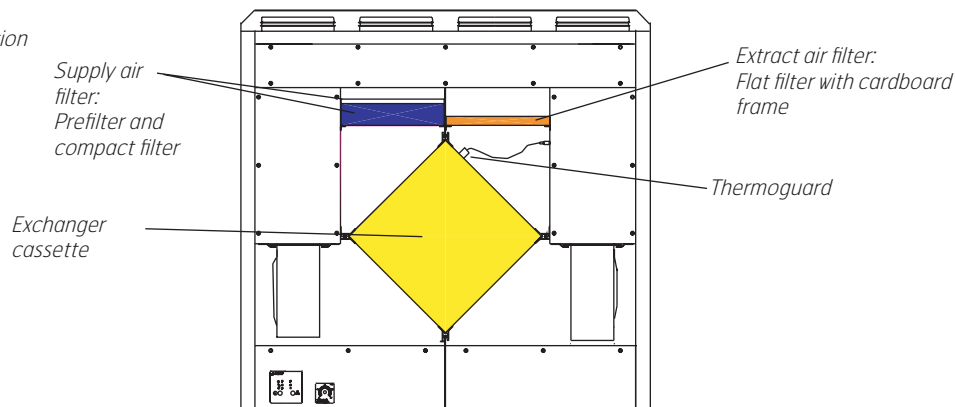

How?

1. Switch off the unit as explained at the top of the page.
2. Pull the extract air filter (1) of type G3 flat filter with a cardboard frame (coarse filter) straight out of the rail. Insert a new filter in the same place
3. Pull the supply air filter (2) out of the rail and insert a new filter in the same place. The supply air filter is of type S4, a composite filter consisting of a prefilter in the form of a G3 flat filter (coarse filter) and an F7 compact filter (fine filter).

The filter set must be installed in the following order, from the exchanger cassette (11): compact filter - prefilter - steel grille. The supply air filter is of type S7, an F7 bag filter with several long bags beside each other.

If the filters are not changed regularly, the following problems will occur:

1. Dirty filters cause increased air resistance and therefore reduce the supply of fresh, filtered air to the home.
2. Dirty, clogged filters reduce the quality of the indoor air.
3. Pollen particles that are caught in the filter may, over time, be released and distributed in the air blown in.
4. A poor indoor environment increases the risk of allergy problems.
5. Bacterial growth may occur in dirty filters and may be distributed in the air blown in.

Order nos. for a complete set of filters: S4 X (TT)/A4 X (TT)- 12318, S7 X (TT)/A4 X (TT) - 12313

5.2 Other Maintenance

Exchanger cassette:

Should be checked roughly once a year for dust and dirt in the air ducts. First remove the thermoguard (3) and carefully pull the cassette (11) out. If cleaning is required, place it in a bowl with warm soapy water (NB! not soda) and finally flush it through with warm water. Clean the thermoguard separately with a dry cloth. When removing/installing the exchanger cassette, it is important to ensure that both the cassette and the sensor rod are located correctly and that the cable plug is inserted in the contact. The thermoguard must be located 6 cm from the top of the exchanger cassette and in the centre of the exchanger cassette. Place it in the area visible beneath the extract air filter (1).

Valves and duct system:

The valves should be cleaned at least once a year. The duct system should be cleaned at least every 10 years.

Outdoor air intake: Check once a year that the grille is not clogged with leaves, dust and dirt.

Roof hat: Check once a year that the drainage gap at the bottom is not clogged with leaves. This applies only if the system has a roof hat.

Summer operation: During the warm part of the year (outdoor air temperature over 15–20^o), there is no need to recover heat. The exchanger cassette can be replaced with a summer cassette that is available as an accessory. This is pushed into place where the exchanger cassette (11) is located. This allows the outdoor air to enter the building directly without heat recovery taking place. The thermoguard (3) must then be transferred to the summer cassette. Its location is shown on the label. NB! At the same time, the heating must be switched off (press the left switch (+) on the control panel so that the green light goes out) to avoid the heating element switching on unnecessarily.



Remember to reverse this again in the autumn

Drainage:

At the base of the unit there is a condensation water drain (14) that conducts condensation water to the waste water drain. It is important that this drain is always open, in good condition and well insulated where it is exposed to frost. It is recommended that you keep an eye on the drainage system to avoid any leaks occurring.

Fans:

Item nos. 9 and 10. The fans normally do not need to be inspected. If necessary, they can be cleaned with a small brush and compressed air, if possible. NB! Do not use water. Disassemble the fans as follows:

S4 X/A4 X: Unscrew 2 screws at the front of each motor. One motor can then be pulled out. The other is located within a distance piece. Pull the fan(s) carefully out of the track and then disconnect the electric quick-release contact so that the fan is completely released. The motor and fan blades are removed by unscrewing the 4 screws in the round motor plate and carefully pulling the motor out of the motor housing.

S7 X/A7 X: Unscrew 2 screws at the bottom front of each fan housing. The entire fan housing can then be pulled straight out. Disconnect the electric quick-release contact so that the fan housing is completely released. The fan is now accessible from the open side.

Kitchen hood/ A model:

For cleaning, see the description in the kitchen hood manual.



Lack of cleaning as prescribed will increase the risk of fire in the event of an accident

6 Overview Drawings

6.1 Overview Drawing, S4 X/TT - A4 X/TT

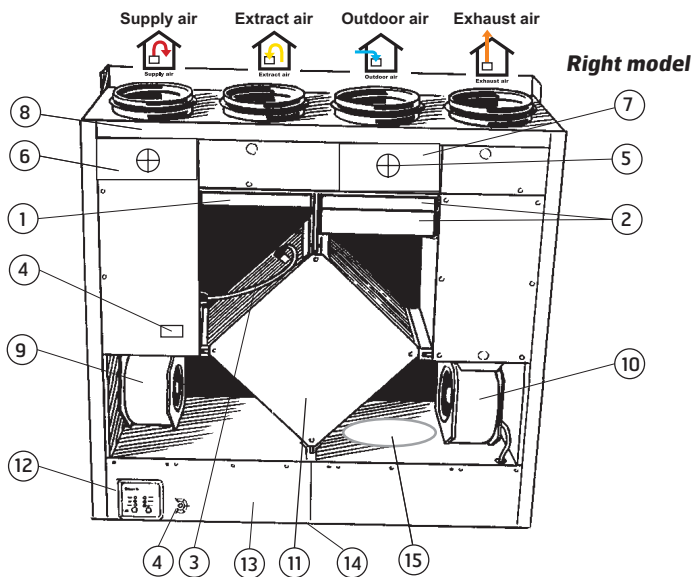

Item Part no.

- 1 G3 extract air filter
- 2 G3 + F7 supply air filter
- 3 Thermoguard
- 4 Heating adjustment
- 5 Preheater
- 6 Heating battery
- 7 Preheating fire thermostat (Reset)
- 8 Heating thermostat (Reset)
- 9 Supply air fan
- 10 Extract air fan
- 11 S4/TT exchanger cassette/cross heat exchanger
- 12 Control switch
- 13 Control unit
- 14 Drainage outlet
- 15 Connection for kitchen hood (only for A model)

6.2 Overview Drawing, S7 X/TT - A7 X/TT

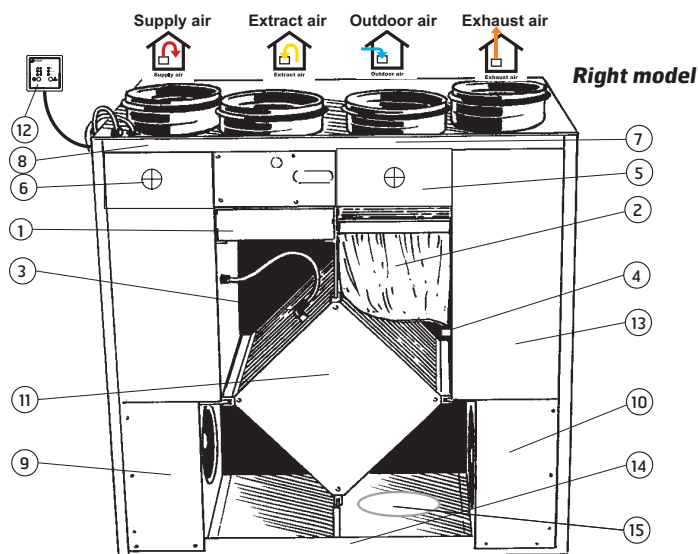

Item Part no.

- 1 G3 extract air filter
- 2 F7 supply air filter (bag)
- 3 Thermoguard
- 4 Heating adjustment
- 5 Preheater
- 6 Heating battery
- 7 Preheating thermostat (Reset)
- 8 Heating fire thermostat (Reset)
- 9 Supply air fan
- 10 Extract air fan
- 11 S7/TT exchanger cassette/cross heat exchanger
- 12 Control switch
- 13 Control unit
- 14 Drainage outlet
- 15 Connection for kitchen hood (only for A model)

7 Technical Data

7.1 Technical data, S4 X/TT - A4 X/TT

	S4 X	S4 X TT
Rated voltage	230 V/50 Hz	230 V/50 Hz
Fuse	10 A	10 A
Rated current, total	8.7 A	8.7 A
Rated power, total	1980 W	1980 W
Rated power, electric batteries	1650 W	975 W
Rated power, fans	2 x 165 W	2 x 165 W
Rated preheating power	975 W	1650 W
Fan type	F-wheel	F-wheel
Fan motor control	Transformer	Transformer
Max. fan speed	2230 RPM	2230 RPM
Standard automatic control	SP30	SP30
Filter type (SUP/EXTR)	F7/G3	F7/G3
Filter dimensions, SUP (WxHxD)	255x220x50 mm	255x220x50 mm
Filter dimensions, EXTR (WxHxD)	255x220x20 mm	255x220x20 mm
Weight	51 kg	56 kg
Duct connection*	Dia. 160 mm	Dia. 160mm
Height	830 mm	830 mm
Width	900 mm	900 mm
Depth	320 mm	320 mm

* For A-model kitchen hood: Dia. 125

All descriptions of Flexit S4 and S7 in this manual also apply to the A models, except where specified otherwise.

7.2 Technical data, S7 X/TT - A7 X/TT

	S7 X	S7 X TT
Rated voltage	230 V/50 Hz	230 V/50 Hz
Fuse	16 A	16 A
Rated current, total	10.4 A	10.4 A
Rated power, total	2380 W	2380 W
Rated power, electric batteries	2000 W	975 W
Rated power, fans	2 x 190 W	2 x 190 W
Rated preheating power	975 W	2000 W
Fan type	B-wheel	B-wheel
Fan motor control	Transformer	Transformer
Max. fan speed	2465 RPM	2465 RPM
Standard automatic control	SP30	SP30
Filter type (SUP/EXTR)	F7/G3	F7/G3
Filter dimensions, SUP (WxHxD)	394x223x250 mm	394x223x250 mm
Filter dimensions, EXTR (WxHxD)	394x223x20 mm	394x223x20 mm
Weight	72 kg	78 kg
Duct connection*	Dia. 200 mm	Dia. 200 mm
Height	935 mm	935 mm
Width	950 mm	950 mm
Depth	458 mm	458 mm

* For A-model kitchen hood: Dia. 125

All descriptions of Flexit S4 and S7 in this manual also apply to the A models, except where specified otherwise.

8 Dimensioned Drawings

S4 X /S4 X TT

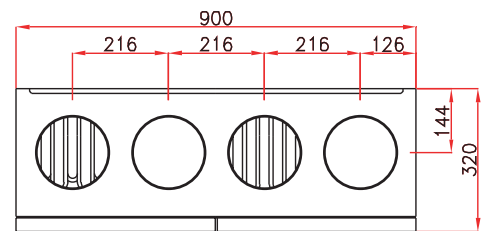
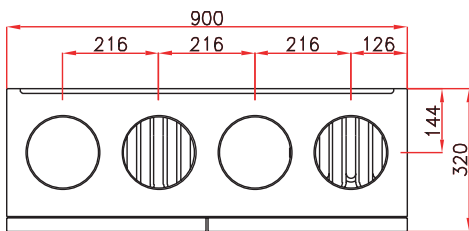
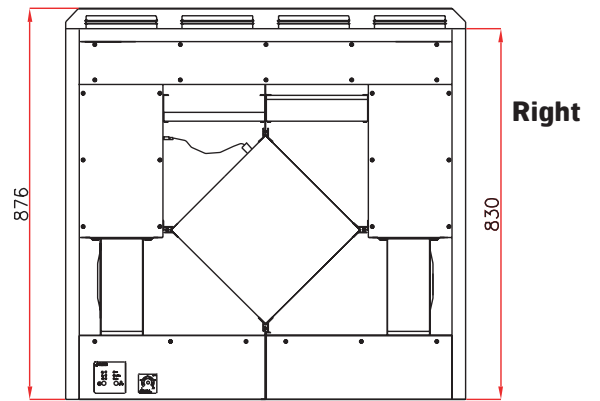
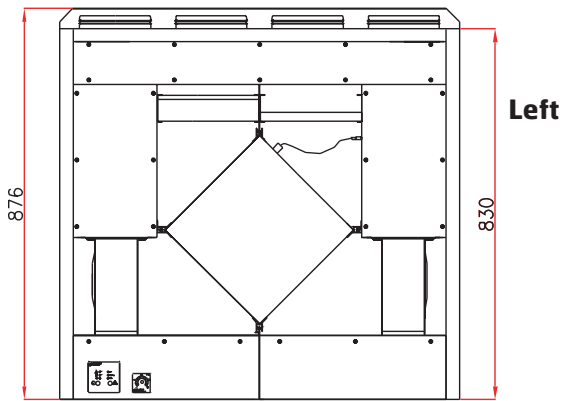

S7 X /S7 X TT

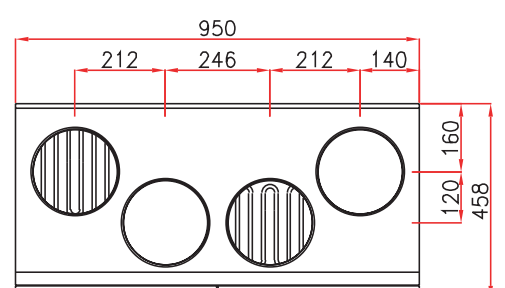
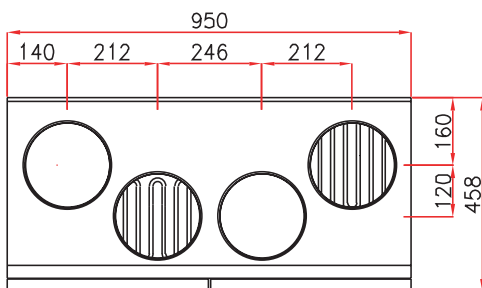
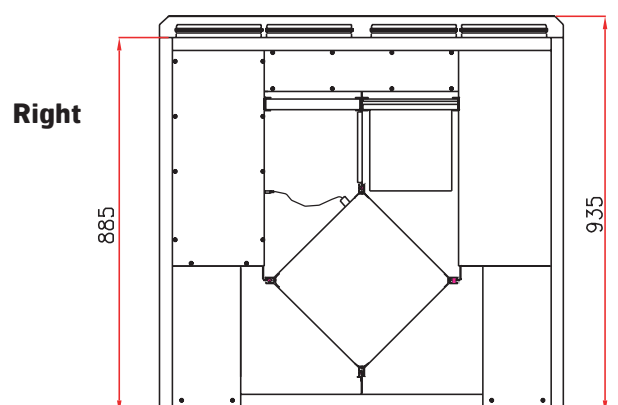
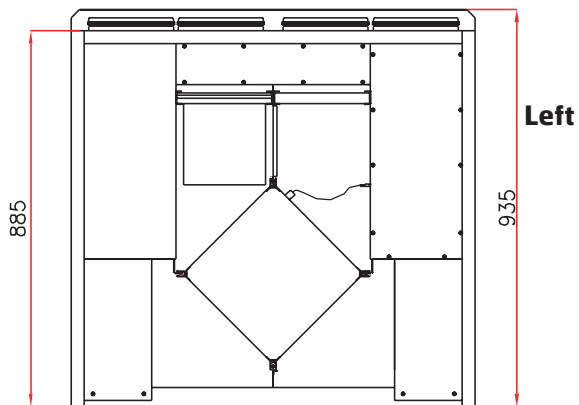

*All measures in mm

9 Adjusting the Unit



Before opening the door of the heat recovery system, switch off the heat, let the fans continue for three minutes to remove hot air, remove the power from the unit and wait 2 minutes before opening the doors.

9.1 Adjustment

The speed of the unit at the normal stage must be set to the voltage specified in the “Documentation of Ventilation Data” form that is enclosed with the ventilation drawings from the company responsible for project planning. Open the door and unscrew and remove the cover of the automatic control compartment. The transformer is then visible (see picture below) and the cables marked 1 2 3 (as shown on page 2) can be switched over to the specified voltage level.

S4X/S4TT: The automatic control compartment is behind the cover at the bottom of the unit.
 S7X/S7TT: The automatic control compartment is always on the right side.

		Extract air	Supply air
Factory setting	150 V	170 V	170 V
Factory setting	150 V	170 V	170 V

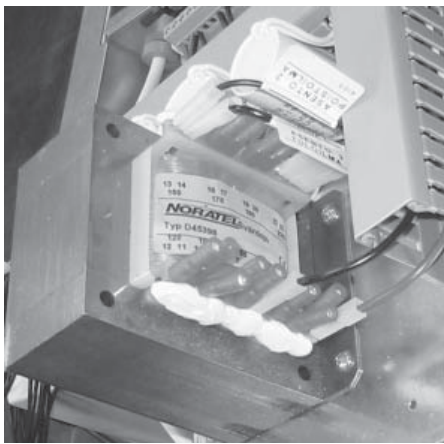

Transformer

11	12	13	14	15	16		18	19	20
150		170		190				230	
120		105		85		60		0	
10	9	8	7	6	5	4	3	2	1

Connection alternatives on the transformer
(label/connection points)

9.2 Control Card Adjustment Options

Dipswitch no.	OFF	ON
1	Heating is not affected with frost protection	Heating is switched off with frost protection
2	Heating and preheating function normally	Heating and preheating are switched off at the min stage
3	Not affected with nighttime temperature reduction	Temperature is reduced by 3°C with night-time temperature reduction
4	Not affected with nighttime temperature reduction	Fan speed is reduced to low with nighttime temperature reduction
5	Preheating element is used only for frost protection	Preheating element is also used for heating
6	Must be in this position	Not used

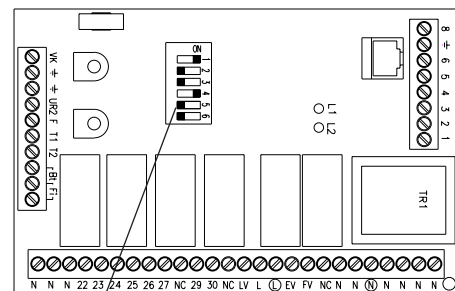

Cross exchanger unit control card
Dipswitch

Bold type shows the standard factory setting. All settings can be combined.

With the standard settings, the unit functions in such a way that heating is available if required with normal operation, while heating is switched off with frost protection operation, when the preheating element takes over.

If both elements are required for heating in cold areas during frost protection operation, switch 1 must be switched to OFF. Please note that the unit’s rated power will then increase with the power of the preheating element. On the L4/S4, 13 A fuses must be used in such cases.

10 CE Declaration of Conformity

This declaration confirms that the products meet the requirements in the following Council Directives and standards:

89/336/EEC Electromagnetic compatibility (EMC)

73/23/EEC Low-voltage Directive (LVD)

EN 60335-1:94, + A11:95, + A1:96, +A1:96, +A12:96

EN 50081-1:92, EN 50082-1:92

Manufacturer: FLEXIT AS, Televeien 15, N-1870 Ørje
Equipment group: Ventilation units for installation in ducts

Type: **Falcon VGS400: 1998**
VGS700: 1998

The product is CE-marked: Shown in the list above

FLEXIT AS 02/05/2001



Pål J. Martinsen
 General Manager

The right to give notice of lack of conformity applies to this product in accordance with the existing terms of sale, provided that the product is correctly used and maintained. Filters are consumables.



The symbol on the product or on its packaging indicates that this product may not be treated as household waste. Instead it shall be handed over to the applicable collection point for the recycling of electrical and electronic equipment.

By ensuring this product is disposed of correctly, you will help prevent potential negative consequences for the environment and human health, which could otherwise be caused by inappropriate waste handling of this product. For more detailed information, please contact your local city office, your household waste disposal service or the shop where you purchased the product.

Notice of lack of conformity as a result of incorrect or defective installation must be submitted to the installation company responsible. The right to give notice of lack of conformity may lapse if the system is used incorrectly or maintenance is grossly neglected.

