

SIEMENS



# Fridge-freezer KD..N..

[siemens-home.com/welcome](https://siemens-home.com/welcome)

en User manual

Register  
your  
product  
online

---

## en Table of Contents

Safety and warning information .....	3	Freezing fresh food .....	10
Information concerning disposal .....	4	Super freezing .....	11
Scope of delivery .....	5	Thawing frozen food .....	12
Ambient temperature and ventilation ..	6	Interior fittings .....	12
Connecting the appliance .....	6	Switching off and disconnecting the appliance .....	13
Getting to know your appliance .....	7	Defrosting .....	13
Switching the appliance on .....	8	Cleaning the appliance .....	13
Setting the temperature .....	8	Light (LED) .....	14
Usable capacity .....	9	Tips for saving energy .....	14
Refrigerator compartment .....	9	Operating noises .....	14
Freezer compartment .....	9	Eliminating minor faults yourself .....	15
Max. freezing capacity .....	10	Customer service .....	17
Freezing and storing food .....	10		

# Safety and warning information

## Before you switch ON the appliance

Please read the operating and installation instructions carefully! They contain important information on how to install, use and maintain the appliance.

The manufacturer is not liable if you fail to comply with the instructions and warnings. Retain all documents for subsequent use or for the next owner.

## Technical safety

This appliance contains a small quantity of environmentally-friendly but flammable R600a refrigerant. Ensure that the tubing of the refrigerant circuit is not damaged during transportation and installation. Leaking refrigerant may cause eye injuries or ignite.

If damage has occurred

- Keep naked flames and/or ignition sources away from the appliance,
- thoroughly ventilate the room for several minutes,
- switch off the appliance and pull out the mains plug,
- inform customer service.

The more refrigerant an appliance contains, the larger the room must be in which the appliance is situated. Leaking refrigerant can form a flammable gas-air mixture in rooms which are too small. The room must be at least 1 m<sup>3</sup> per 8 g of refrigerant. The amount of refrigerant in your appliance is indicated on the rating plate inside the appliance.

If the power cord of this appliance is damaged, it must be replaced by the manufacturer, customer service or a similarly qualified person. Improper installations and repairs may put the user at considerable risk.

Repairs may be performed by the manufacturer, customer service or a similarly qualified person only.

Only original parts supplied by the manufacturer may be used. The manufacturer guarantees that only these parts satisfy the safety requirements.

A extension cable may be purchased from customer service only.

## Important information when using the appliance

- Never use electrical appliances inside the appliance (e.g. heater, electric ice maker, etc.). Risk of explosion!
- Never use a steam cleaner to defrost or clean the appliance! The steam may penetrate electrical parts and cause a short-circuit. Risk of electric shock!
- Do not use pointed and sharp-edged implements to remove frost or layers of ice. You could damage the refrigerant tubes. Leaking refrigerant may ignite or cause eye injuries.
- Do not store products which contain flammable propellants (e.g. spray cans) or explosive substances in the appliance. Risk of explosion!
- Do not stand on or lean heavily against base of appliance, drawers or doors, etc
- To clean the appliance, pull out the mains plug or switch off the fuse! Do not pull out the mains plug by tugging the cable.

## en

- Bottles which contain a high percentage of alcohol must be sealed and stored in an upright position.
- Keep plastic parts and the door seal free of oil and grease. Otherwise, parts and door seal will become porous.
- Never cover or block the ventilation openings for the appliance.
- People (children incl.) who have limited physical, sensory or mental abilities or inadequate knowledge must not use this appliance unless they are supervised or given meticulous instructions.
- Do not store bottled or canned drinks (especially carbonated drinks) in the freezer compartment. Bottles and cans may explode!
- Never put frozen food straight from the freezer compartment into your mouth.  
Risk of low-temperature burns!
- Avoid prolonged touching of frozen food, ice or the evaporator pipes, etc.  
Risk of low-temperature burns!

### Children in the household

- Keep children away from packaging and its parts.  
Danger of suffocation from folding cartons and plastic film!
- Do not allow children to play with the appliance!
- If the appliance features a lock: keep the key out of the reach of children!

## General regulations

The appliance is suitable

- for refrigerating and freezing food,
- for making ice,
- for dispensing drinking water.

This appliance is intended for use in the home and the home environment.

The appliance is suppressed according to EU Directive 2004/108/EC.

The refrigeration circuit has been checked for leaks.

This product complies with the relevant safety regulations for electrical appliances (EN 60335-2-24).

---

## Information concerning disposal

### Disposal of packaging

The packaging protects your appliance from damage during transit. All utilised materials are environmentally safe and recyclable. Please help us by disposing of the packaging in an environmentally friendly manner.

Please ask your dealer or inquire at your local authority about current means of disposal.

## Disposal of your old appliance

Old appliances are not worthless rubbish! Valuable raw materials can be reclaimed by recycling old appliances.



This appliance is identified according to the European guideline 2002/96/EC on waste electrical and electronic equipment – WEEE. The directive specifies the framework for an EU-wide valid return and re-use of old appliances.

### Warning

Redundant appliances

1. Pull out the mains plug.
2. Cut off the power cord and discard with the mains plug.
3. Do not take out the trays and receptacles: children are therefore prevented from climbing in!
4. Do not allow children to play with the appliance once it has spent its useful life. Danger of suffocation!

Refrigerators contain refrigerant and gases in the insulation. Refrigerant and gases must be disposed of professionally. Ensure that tubing of the refrigerant circuit is not damaged prior to proper disposal.

---

## Scope of delivery

After unpacking all parts, check for any damage in transit.

If you have any complaints, please contact the dealer from whom you purchased the appliance or our customer service.

The delivery consists of the following parts:

- Free-standing appliance
- Bag containing installation materials
- Interior fittings (depending on model)
- Operating instructions
- Installation manual
- Customer service booklet
- Warranty enclosure
- Information on the energy consumption and noises

## Ambient temperature and ventilation

### Ambient temperature

The appliance is designed for a specific climate class. Depending on the climate class, the appliance can be operated at the following temperatures.

The climate class can be found on the rating plate. Fig. **7**

Climate class	Permitted ambient temperature
<b>SN</b>	+10 °C to 32 °C
<b>N</b>	+16 °C to 32 °C
<b>ST</b>	+16 °C to 38 °C
<b>T</b>	+16 °C to 43 °C

### Note

The appliance is fully functional within the room temperature limits of the indicated climatic class. If an appliance of climatic class SN is operated at colder room temperatures, the appliance will not be damaged up to a temperature of +5 °C.

### Ventilation

Fig. **2**

The air on the rear panel and on the side panels of the appliance heats up. Conduction of the heated air must not be obstructed. Otherwise, the refrigerating unit must work harder. This increases power consumption. Therefore: Never cover or block the ventilation openings!

## Connecting the appliance

After installing the appliance, wait at least 1 hour until the appliance is switched on. During transportation the oil in the compressor may have flowed into the refrigeration system.

Before switching on the appliance for the first time, clean the interior of the appliance (see chapter “Cleaning the appliance”).

### Electrical connection

The socket must be near the appliance and also freely accessible following installation of the appliance.

The appliance complies with the protection class I. Connect the appliance to 220–240 V/50 Hz alternating current via a correctly installed socket with protective conductor. The socket must be fused with a 10 to 16 A fuse.

For appliances operated in non-European countries, check whether the stated voltage and current type match the values of your mains supply match the values of the mains supply. This information can be found on the rating plate. Fig. **7**

## Warning

Never connect the appliance to electronic energy saver plugs.

Our appliances can be used with mains and sine-controlled inverters. Mains-controlled inverters are used for photovoltaic systems which are connected directly to the national grid. Sine-controlled inverters must be used for isolated applications (e.g. on ships or in mountain lodges) which are not connected directly to the national grid.

---

## Getting to know your appliance

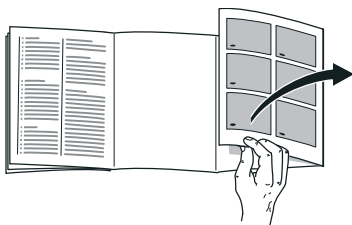

Please fold out the illustrated last page. These operating instructions refer to several models.

The features of the models may vary.

The diagrams may differ.

Fig. 1

\* Not all models.

- 1-4 Controls
- 5 Temperature controller
- 6 Fast freezer compartment\*
- 7 Ice maker \*
- 8 Ice cube container\*
- 9 Light switch
- 10 Extendable glass shelf
- 11 Air outlet opening
- 12 Light (LED)
- 13 Shelf in the refrigerator compartment
- 14 Bottle shelf \*
- 15 Cold storage compartment
- 16 Vegetable container
- 17 Height-adjustable feet
- 18 Egg rack
- 19 Door shelf
- 20 Shelf for large bottles
  
- A Freezer compartment
- B Refrigerator compartment

## Controls

- 1 **On/Off button**  
Serves to switch the whole appliance on and off.
- 2 **Selection button for freezer compartment**  
The freezer compartment temperature can be selected from  $-24\text{ °C}$  to  $-16\text{ °C}$ .  
The set temperature is indicated on display 3.
- 3 **Temperature display freezer compartment**  
The numbers next to the temperature display lights correspond to freezer compartment temperatures in  $^{\circ}\text{C}$ . The lit lamp indicates the selected temperature.
- 4 **“Super” button (freezer compartment)**  
Switches super freezing on and off.

---

## Switching the appliance on

Fig. 1

Switch on the appliance with the On/Off button 1.

The temperature display 3 flashes until the appliance has reached the set temperature.

The appliance begins to cool. Light is switched on when the door is open.

The factory has recommended the following temperatures:

- Refrigerator compartment:  $+4\text{ °C}$
- Freezer compartment:  $-18\text{ °C}$

## Operating tips

- When the appliance has been switched on, it may take several hours until the set temperatures have been reached.
- The fully automatic No Frost system ensures that the freezer compartment remains free of ice. Defrosting is no longer required.
- The sides of the housing are sometimes heated slightly. This prevents condensation in the area of the door seal.
- If the freezer compartment door cannot be immediately re-opened after it has been closed, wait until the resulting low pressure has equalised.

---

## Setting the temperature

### Refrigerator compartment

Turn temperature controller, Fig. 1/5, to the required setting.

We recommend a medium setting.

Higher settings lower the temperature in the refrigerator compartment.

Select a higher setting only temporarily if:

- the ambient temperature is high,
- door is opened frequently,
- large quantities of food are placed in the refrigerator compartment.



## Freezer compartment

The temperature can be set from -16 °C to -24 °C.

Keep pressing temperature setting button 2 until the required freezer compartment temperature is set.

The value last selected is saved. The set temperature is indicated on display 3.

## Usable capacity

Information on the usable capacity can be found inside your appliance on the rating plate. Fig. 7

## Refrigerator compartment

The refrigerator compartment is the ideal storage location for ready meals, cakes and pastries, preserved food, condensed milk, hard cheese, fruit and vegetables sensitive to cold as well as tropical fruit.

### Note when loading products

Wrap or cover food before placing in the appliance. This will retain the aroma, colour and freshness of the food. In addition, flavours will not be transferred between foods and the plastic parts will not become discoloured.

#### Note

Avoid contact between food and rear panel. Otherwise the air circulation will be impaired.

Food or packaging could freeze to the rear panel.

## Note the chill zones in the refrigerator compartment

The air circulation in the refrigerator compartment creates different chill zones:

#### ■ Coldest zone

is on the rear panel inside the appliance and on the cold storage compartment. Fig. 11/15

#### Note

Store perishable food e.g. fish, sausage, meat in the coldest zones.

#### ■ Warmest zone

is at the very top of the door.

#### Note

Store e.g. cheese and butter in the warmest zone. When served, the cheese will not have lost its flavour and the butter will be easy to spread.

## Freezer compartment

### Use the freezer compartment

- To store deep-frozen food.
- To make ice cubes.
- To freeze food.

#### Note

Ensure that the freezer compartment door has been closed properly. If the door is open, the frozen food will thaw. The freezer compartment will become covered in thick ice. Also: waste of energy due to high power consumption!

---

## Max. freezing capacity

Information about the max. freezing capacity within 24 hours can be found on the rating plate. Fig. 7

---

## Freezing and storing food

### Purchasing frozen food

- Packaging must not be damaged.
- Use by the “use by” date.
- Temperature in the supermarket freezer must be -18 °C or lower.
- If possible, transport deep-frozen food in an insulated bag and place quickly in the freezer compartment.

### Note when loading products

Freeze large quantities of food in the fast freezer compartment where food freezes particularly quickly and therefore also gently.

Food which is already frozen must not come into contact with the food which is to be frozen.

---

## Freezing fresh food

Freeze fresh and undamaged food only.

To retain the best possible nutritional value, flavour and colour, vegetables should be blanched before freezing. Aubergines, peppers, zucchini and asparagus do not require blanching. Literature on freezing and blanching can be found in bookshops.

### Note

Keep food which is to be frozen away from food which is already frozen.

- The following foods are suitable for freezing:
  - Cakes and pastries, fish and seafood, meat, game, poultry, vegetables, fruit, herbs, eggs without shells, dairy products such as cheese, butter and quark, ready meals and leftovers such as soups, stews, cooked meat and fish, potato dishes, soufflés and desserts.
- The following foods are not suitable for freezing:
  - Types of vegetables, which are usually consumed raw, such as lettuce or radishes, eggs in shells, grapes, whole apples, pears and peaches, hard-boiled eggs, yoghurt, soured milk, sour cream, crème fraîche and mayonnaise.

## Packing frozen food

To prevent food from losing its flavour or drying out, place in airtight containers.

1. Place food in packaging.
2. Remove air.
3. Seal the wrapping.
4. Label packaging with contents and date of freezing.

### Suitable packaging:

Plastic film, tubular film made of polyethylene, aluminium foil, freezer containers.

These products are available from specialist outlets.

### Unsuitable packaging:

Wrapping paper, greaseproof paper, cellophane, bin liners and used shopping bags.

### Items suitable for sealing packaged food:

Rubber bands, plastic clips, string, cold-resistant adhesive tape, etc.

Bags and tubular film made of polyethylene can be sealed with a film heat sealer.

## Shelf life of frozen food

Storage duration depends on the type of food.

At a temperature of -18 °C:

- Fish, sausage, ready meals and cakes and pastries:  
up to 6 months
- Cheese, poultry and meat:  
up to 8 months
- Vegetables and fruit:  
up to 12 months

---

## Super freezing

Food should be frozen solid as quickly as possible in order to retain vitamins, nutritional value, appearance and flavour.

Several hours before placing fresh food in the freezer compartment, switch on super freezing to prevent an unwanted temperature rise.

As a rule, 4-6 hours is adequate.

This appliance runs constantly and the freezer compartment drops to a very low temperature.

If the max. freezing capacity is to be used, super freezing must be switched on for 24 hours before the fresh produce is placed in the freezer compartment.

Smaller quantities of food (up to 2 kg) can be frozen without "super freezing".

### Note

When super freezing is switched on, increased operating noises may occur.

## Switching on and off

Fig. 1

Press "super" button 4.

If the super freezing has been switched on the button is lit.

Super freezing automatically switches off after approx. 2½ days.

---

## Thawing frozen food

Depending on the type and application, select one of the following options:

- at room temperature
- in the refrigerator
- in an electric oven, with/without fan assisted hot-air
- in the microwave

### **Caution**

Do not refreeze thawing or thawed food. Only ready meals (boiled or fried) may be refrozen.

No longer store the frozen produce for the max. storage period.

---

## Interior fittings

You can reposition the shelves inside the appliance and the door shelves as required:

- Pull shelf forwards, lower and swing out to the side.
- Raise the door shelf and remove.

## Special features

(not all models)

### **Taking out the extendable glass shelf**

Fig. **1**/10

The glass shelf can be removed for cleaning. To do this, pull out shelf, lift at the front and take out.

### **Bottle shelf**

Fig. **1**/14

Bottles can be stored securely on the bottle shelf. The holder can be adjusted.

### **Cold storage compartment**

Fig. **1**/15

The cold storage compartment has lower temperatures than the refrigerator compartment. Even temperatures below 0 °C may occur.

Ideal for storing fish, meat and sausage. Not suitable for lettuce and vegetables and produce sensitive to cold.

### **Ice maker**

Fig. **3**

1. Remove the ice cube tray, fill  $\frac{3}{4}$  full of water and re-insert.
2. When the ice cubes are frozen, rotate the knobs on the ice cube trays several times to the right and release. The ice cubes loosen and fall into the storage container.
3. Remove ice cubes from the storage container.

### **Ice cube tray**

Fill the ice cube tray  $\frac{3}{4}$  full of water and place in the freezer compartment.

If the ice tray is stuck to the freezer compartment, loosen with a blunt implement only (spoon-handle).

To loosen the ice cubes, twist the ice tray slightly or hold briefly under flowing water.

### **Vegetable container with humidity control**

Fig. **4**

To create the optimum storage climate for vegetables, salad and fruit, the air humidity in vegetable container can be regulated according to the quantity stored.

**Smaller quantities of food** – slide the regulator to the right.

**Larger quantities of food** – slide the regulator to the left.

---

## Switching off and disconnecting the appliance

### Switching off the appliance

Fig. 1

Press the On/Off button 1.  
Refrigerating unit and light switch off.

### Disconnecting the appliance

If you do not use the appliance for a prolonged period:

1. Switch off the appliance.
2. Pull out mains plug or switch off fuse.
3. Clean the appliance.
4. Leave the appliance door open.

---

## Defrosting

### Refrigerator compartment

Defrosting is actuated automatically. The condensation runs through the drainage hole into an evaporation pan on the rear of the appliance.

### Freezer compartment

The fully automatic No Frost system ensures that the freezer compartment remains free of ice. Defrosting is no longer required.

---

## Cleaning the appliance

### Caution

- Do not use abrasive, chloride or acidic cleaning agents or solvents.
- Do not use scouring or abrasive sponges.  
The metallic surfaces could corrode.
- Never clean shelves and containers in the dishwasher.  
The parts may warp!

### Water used for cleaning must not drip into the

- slots in the front base area in the freezer compartment,
- controls,
- and light.

### Proceed as follows:

1. Before cleaning: Switch the appliance off.
2. Pull out the mains plug or switch off the fuse.
3. Take out the frozen food and store in a cool location. Place the ice pack (if enclosed) on the food.
4. Clean the appliance with a soft cloth, lukewarm water and a little pH neutral washing-up liquid. The rinsing water must not run into the light.
5. Wipe the door seal with clear water only and then wipe dry thoroughly.
6. After cleaning reconnect and switch the appliance back on.
7. Put the frozen food back in the freezer compartment.

## Interior fittings

All variable parts of the appliance can be taken out for cleaning.

### Take out glass shelves

Pull the glass shelves forwards and take out.

---

## Light (LED)

Your appliance features a maintenance-free LED light.

These lights may be repaired by customer service or authorised technicians only.

---

## Tips for saving energy

- Install the appliance in a dry, well ventilated room! The appliance should not be installed in direct sunlight or near a heat source (e.g. radiator, cooker).

If required, use an insulating plate.

- Allow warm food and drinks to cool down before placing in the appliance.
- Thaw frozen food in the refrigerator compartment and use the low temperature of the frozen food to cool refrigerated food.
- Open the appliance as briefly as possible.
- Occasionally clean the rear of the appliance to prevent an increased power consumption.

- If available: Fit wall spacers to obtain the indicated energy rating of the appliance (see Installation instructions). A reduced wall gap will not restrict the function of the appliance. The energy rating may then change slightly. The gap of 75 mm must not be exceeded.

---

## Operating noises

### Quite normal noises

#### Droning

Motors are running (e.g. refrigerating units, fan).

#### Bubbling, humming or gurgling noises

Refrigerant is flowing through the tubing.

#### Clicking

Motor, switches or solenoid valves are switching on/off.

#### Cracking

Automatic defrosting is running.

## Preventing noises

### The appliance is not level

Please align the appliance with a spirit level. Use the height-adjustable feet or place packing underneath them.

### The appliance is not free-standing

Please move the appliance away from adjacent units or appliances.

**Containers or storage areas wobble or stick**

Please check the removable parts and re-insert them correctly if required.

**Bottles or receptacles are touching each other**

Move the bottles or receptacles slightly away from each other.

---

## Eliminating minor faults yourself

Before you call customer service:

Please check whether you can eliminate the fault yourself based on the following information.

Customer service will charge you for advice – even if the appliance is still under guarantee!

<b>Fault</b>	<b>Possible cause</b>	<b>Remedial action</b>
Temperature differs greatly from the set value.		<p>In some cases it is adequate to switch off the appliance for 5 minutes.</p> <p>If the temperature is too high wait a few hours and check whether the temperature has approached the set value.</p> <p>If the temperature is too low check the temperature again the next day.</p>
The light does not function.	The LED light is defective.	See chapter “Light (LED)” section.
	<p>Appliance was open too long.</p> <p>Light is switched off after approx. 10 min.</p>	When the appliance is closed and opened, the light is on again.
Displays do not illuminate.	Power failure; the fuse has been switched off; the mains plug has not been inserted properly.	Connect mains plug. Check whether the power is on, check the fuses.

---

Fault	Possible cause	Remedial action
The temperature in the freezer compartment is too warm.	Appliance opened frequently.	Do not open the appliance unnecessarily.
	The ventilation openings have been covered.	Remove obstacles.
	Large quantities of fresh food are being frozen.	Do not exceed max. freezing capacity.
Freezer compartment door was open for a long time; temperature is no longer reached.	The evaporator (refrigeration generator) in the No Frost system is covered in thick ice and can no longer be defrosted fully automatically.	<p>To defrost the evaporator, remove the frozen food with the compartments, insulate well and store in a cool location.</p> <p>Switch off the appliance and move it away from the wall. Leave the appliance door open.</p> <p>After approx. 20 min. the condensation begins to run into the evaporation pan, at the rear of the appliance. Fig. <b>6</b></p> <p>To prevent the evaporation pan from overflowing in this case, mop up the condensation with a sponge.</p> <p>The evaporator is defrosted when the water stops running into the evaporation pan. Clean the interior. Switch the appliance back on again.</p>



---

## Customer service

Your local customer service can be found in the telephone directory or in the customer-service index. Please provide customer service with the appliance product number (E-Nr.) and production number (FD).

These specifications can be found on the rating plate. Fig. **7**

To prevent unnecessary call-outs, please assist customer service by quoting the product and production numbers. This will save you additional costs.

## Repair order and advice on faults

Contact information for all countries can be found on the enclosed customer service list.

GB	0844 8928999	Calls from a BT landline will be charged at up to 3 pence per minute. A call set-up fee of up to 6 pence may apply.
IE	01450 2655	
US	866 447 4363	toll-free

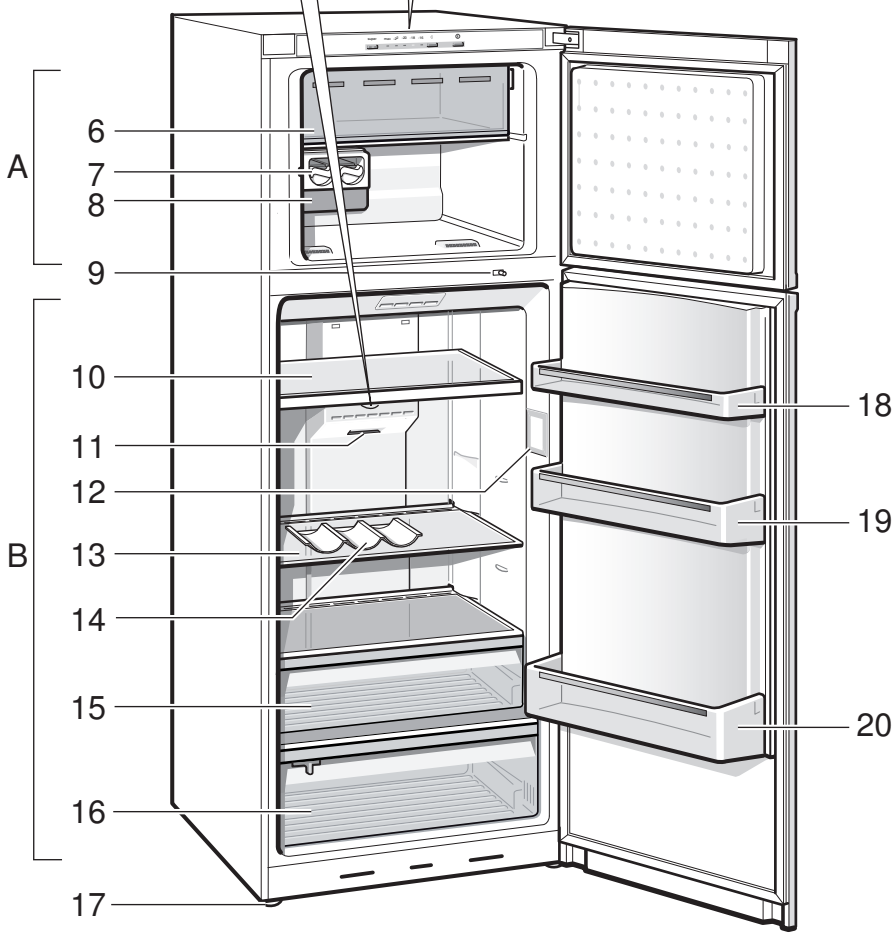
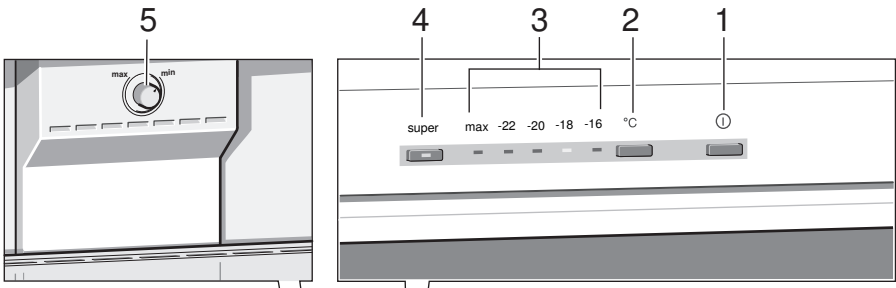

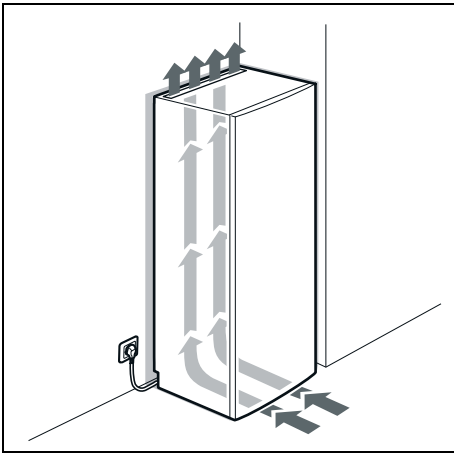

2

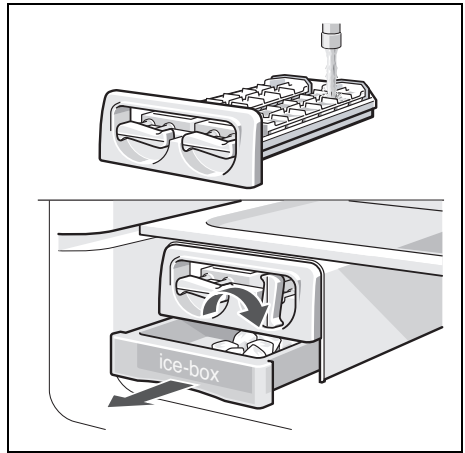

3

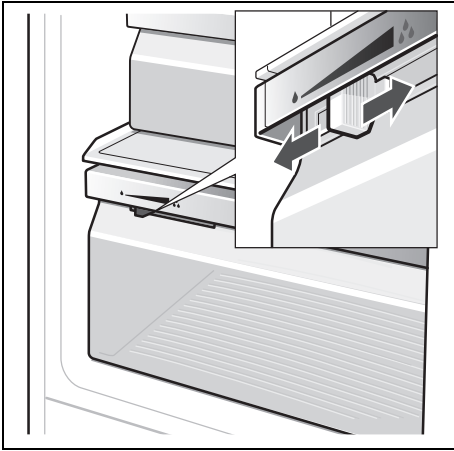

4

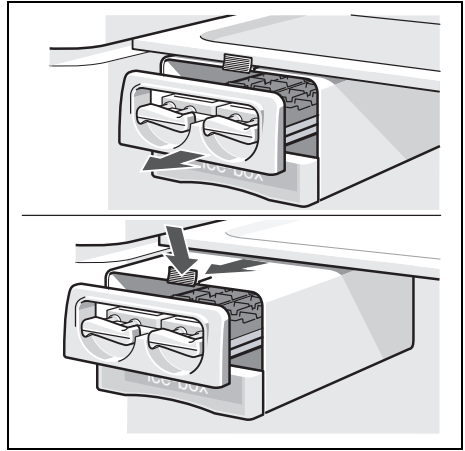

5

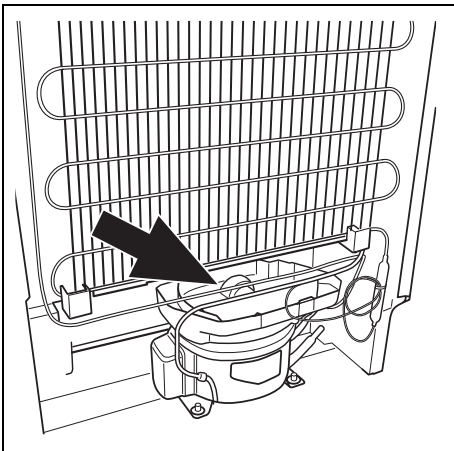

6

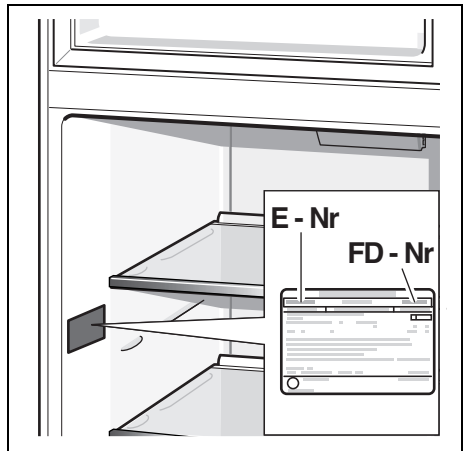

7

BSH Hausgeräte GmbH  
Carl-Wery-Straße 34  
81739 München, GERMANY

[siemens-home.com](https://www.siemens-home.com)

**9000782376(9412)**  
en