



Newport.

ORIEL PRODUCT LINE

150 Long Beach Boulevard
Stratford, CT 06615
Phone: (203) 377-8282
(800) 714-5393
Fax: (203) 378-2457
E-MAIL oriel.sales@newport.com

MERLIN™ RADIOMETRY SYSTEMS

MODELS 70100 THRU 70105

USER MANUAL

Please read these instructions completely before operating this equipment. The specification and operating instructions apply only to the model(s) covered by this manual. If there are any questions or problems regarding the use of this equipment, please contact Newport or the representative from whom this equipment was purchased.

Rev: 10-31-07

TABLE OF CONTENTS

I.	INTRODUCTION	1
II.	"15 MINUTE EXPERT"™	3
	II.1 STARTING	3
	II.2 INTENSITY MONITOR.....	5
	II.3 CALIBRATED OPERATION	6
	II.4 OPERATION IN A RATIO MODE	6
	II.5 COMPUTERIZED USAGE	7
III.	MERLIN™ RADIOMETER DESCRIPTION	8
	III.1 SYSTEM CONFIGURATION	8
	III.2 ANALOG SIGNAL PROCESSING SECTION	10
	III.3 DIGITAL SIGNAL PROCESSING	11
	III.4 CHOPPER CONTROL.....	12
	III.5 FRONT PANEL DISPLAY/KEY PAD/FUNCTION KEYS	13
	III.6 COMMUNICATIONS INTERFACE	14
	III.7 POWER SUPPLY	14
IV.	SPECIFICATIONS	15
V.	CIRCUIT DESCRIPTION	16
	V.1 ASP	16
	V.2 DSP	16
	V.3 CHOPPER CONTROL.....	16
	V.4 DETECTOR LNTERFACE.....	16
	V.5 COMPUTER LNTERFACE	17
VI.	MENU SCREENS	18
VII.	STAND-ALONE OPERATION OF MERLIN™ DETECTOR.....	55
	VII.1 SINGLE SIGNAL VS. RATIO	56
	VII.2 SINGLE PHASE VS. TWO PHASE PROCESSING	56
	VII.3 CALIBRATED DETECTOR OPERATION.....	57
	VII.4 INTERNAL/EXTERNAL CHOPPER CONTROL.....	57
	VII.5 TWO CONFIGURATION CAPABILITY	58
	VII.6 MODEL 70102, SECOND DETECTOR CHANNEL	58
	VII.7 INSTALLATION INSTRUCTIONS FOR MERLIN™ ADDITIONAL DETECTOR CHANNEL MODEL 70102..	59
VIII.	COMPUTER CONTROLLED OPERATION OF MERLIN™	60
	VIII.1 THE RUNES™ SOFTWARE PACKAGE.....	61
	VIII.2 TALKING TO MERLIN™	63
	VIII.3 ACCESSING THE DISPLAYED READING.....	64
	VIII.4 PROGRAMMABLE FUNCTIONS.....	66
	VIII.5 SPECIAL PROCEDURES.....	68
	VIII.6 WAVELENGTH TABLE DATA.....	73
	VIII.7 IEEE - 488 SAMPLE SESSION.....	75
IX.	DECLARATION OF CONFORMITY	77
X.	WARRANTY AND RETURNS	78

I. INTRODUCTION

Thank you for choosing MERLIN™ radiometer system for your light measurement needs. This unit was designed to provide all the necessary functions needed for phase sensitive detection of low level light signals, or Lock-In Amplification, utilizing state of the art digital signal processing techniques. Chopper control board and multi-detector compatible, dual channel interface board are included with the unit.

A computer interface (either RS-232 or IEEE-488) is part of the basic unit. A second full function detector interface channel may be ordered as part of the Merlin™ (Models 70104 and 701 05) or the second detector channel may be purchased separately (Model 701 02) for upgrading a single channel unit.

The "**15 MINUTE EXPERT**"™ section, which follows, will introduce you to some typical setups which take advantage of the power of this unit. More detailed descriptions of various menu and equipment options are contained in the remainder of the manual and in the manuals of the individual components, e.g. choppers and detectors.

A basic Merlin™ System consists of a chopper, a detector head and the Merlin™ control and processing unit. The chopper modulates the radiation to be measured. The detector head senses the chopped radiation and the zero level as the blade blocks the beam. The Merlin™ control unit drives the chopper and acts as a lock-in amplifier to retrieve the signal and ignore detector signal from un-chopped radiation. Merlin™ computes the signal value using any previously input calibration data. The signal value is displayed in appropriate units.

The Merlin™ Advantage

The Merlin™ incorporates a true digital lock-in. A new, powerful, signal processing computer performs the demodulation and filtering. This allows greater flexibility and fidelity than that available from conventional lock in hardware since the post-demodulator gain is not subject to the drift that limits analog lock-ins. Select single or dual phase operation and single or double time constant (one or two pole filtering) as needed. The impressive computational capability allows immediate signal rationing and conversion and forms the basis of our Smart Ranging™.

Versatility With Simplicity

You can use a Merlin™ System to measure very low light levels in the visible, recording the results in picowatts. You can then switch to the infrared to detect low level signals and switch the display to dBm if you prefer. We offer broadband pyroelectric detectors and sensitive silicon and lead sulfide detectors. We also provide photomultipliers for the visible and ultraviolet. All of these detectors have optimized preamplifiers matched to Merlin™. No longer do you need to select a lock-in, find a detector, experiment with preamplifiers, and then puzzle over the output. Merlin™ takes the mystery out of radiation measurement.

It is not only the comprehensive family of detectors and the menu driven software that affords versatility. The hardware design is based on PC computer style plug-in cards (see Fig. 1). Each basic Merlin™ has two free slots for optional hardware enhancements.

Calibrated Performance

Most lock-in based radiometers display the result in volts; we calibrate all Merlin™ systems to read out in radiometric or spectroradiometric units. Units include watts, $\text{watts cm}^{-2} \text{ nm}^{-1}$ and dBm, as well as volts.

We have been calibrating radiometers with spectrally neutral (**black**) detectors for many years. The responsivity of these is independent of wavelength, but they are only useful if you are measuring radiation power above the 10-100 nW level. Unfortunately, for lower power levels you must use a **photon detector**. The responsivity of all these detectors, photomultipliers, silicon photodiodes or sensitive infrared detectors, or any detector-spectrometer combination varies with wavelength.

To address this, we offer wavelength calibration capability with our Merlin™ Systems for calibrated measurement of even low power monochromatic sources. We do this in two ways; we offer Calibration PROMS (Programmable Read Only Memory) for selected detectors, and we allow you to store a responsivity/wavelength table in memory. If you let Merlin™ know the wavelength, either by manual keyboard entry or by computer, the calibration data is used to compute the power.

II. "15 MINUTE EXPERT"™

II.1 STARTING

- A. Before plugging the unit into an electrical outlet please check that the voltage selector, located next to the power cord receptacle, is set to the correct position of 115 OR 230 VAC.

SAFETY: Please make sure that the unit is not plugged into an electrical outlet before attempting any service activities.

A small, flat blade screwdriver will be needed to modify the voltage setting. The correction can be accomplished by pulling the voltage module out from the unit, gently pushing the screwdriver blade between the black module housing and the green voltage selector until the latch, indicated by a black arrow, is released, and then pulling the green voltage selector out. Replace the voltage selector in appropriate orientation for your supply voltage.

- B. The On/Off switch is located next to the voltage selector.
- C. Turning the unit off and then turning it back on while pressing the leftmost MENU SELECTION key on the front panel (Figure 1), will reset the unit to factory preset menu selections. We would like to encourage you to explore the means of accessing various menu options through the four "soft-buttons" and the numeric key-pad to get comfortable with the way the unit responds. The exact meaning of the various options will be explained later. Use the reset function to return to original menu selections at the end of this exercise.

NOTE: Brightness and contrast functions are independent of the reset. The display adjustments are done by holding down the brightness or contrast buttons and pressing the up or down arrow keys.

MERLIN HARDWARE

Merlin Control Units contains the key printed circuit boards. These boards are removable for ease of servicing. All are powered by the internal power supply through the backplane bus. Two open slot are open for dual channel radiometry and other options.

CHOPPER CONTROL BOARD

Each Merlin includes a variable frequency chopper drive and control board. This board operates the Oriel 75154 Open and 75152 Enclosed Chopper Heads and uses the opto sensors on the head for frequency control. The advance drive features rapid slew rate, fast settling time and extremely tight frequency control of the servo loop. Chopping frequencies to 1100 Hz are selectable from the menu. The optimum chopping frequency depends on the detector type, any modulation of undesired ambient radiation and the power spectrum of interfering electromagnetic noise. Input synch pulses allow synchronization to externally controller choppers.

ANALOG SIGNAL PROCESSOR BOARD

This low noise board has an extremely wide dynamic range amplifier chain. The Smart Ranging™ features does not require switching of amplifier stages. Merlin monitors all amplifiers all the time, checking for gain stage saturation. The processor uses this information to determine signal level. There is no time or signal information lost in hardware range switching.

COMMUNICATION BOARD
 This RS 232 link has selectable baud rates to 9600 and is available for data uptake or calibration downloading.

DIGITAL SIGNAL PROCESSOR BOARD

The digital signal processor board uses a digital signal processing microcomputer, optimized for high speed number crunching. This new device gives orders of magnitude improvement in signal processing capability over conventional processors. It operates on 16 bit data at 10 mips (10 million instructions per second), creating 32 bit outputs with 40 bit accumulator and registers. The microcomputer utilizes three computational units, data address generators, a program sequencer, two serial ports, a programmable timer, extensive interrupt capability, and on-board program and data SRAM. This extensive architecture is required for the demanding signal processing involved in precise measurement of the input signal and conversion to meaningful units. The processor selects data, calculates the magnitude and phase, filters the data, converts to radiometric units or ratios as required. At the same time the processors controls the data taking, keeps the chopper operating at exactly the right frequency, display the results and takes care of communications. The signal processor board also holds the non-volatile memory for savings menu, calibration and set-up data.

FRONT PANEL INTERFACE BOARD
 This board controls display and also process entries from the keypad and menu functions keys.

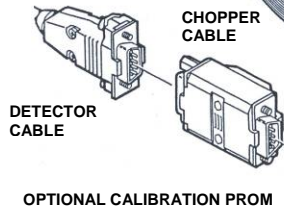

DETECTOR INTERFACE BOARD

The detector Interface Board is Merlin's connection with any of its detector heads. A single socket carries signal and regulated $\pm 15V$ detector preamplifier supply connections. The board includes line notch filters and an instrumentation amplifier for signal conditioning. When a detector with Calibration PROM is connected, Merlin automatically utilizes the identification and calibration information. This board also has an input reference socket for a 0-10 volt DC Input. Reference inputs are typically derived from a reference photodiode such as that on the Oriel Photofeedback System, or from control current or voltage reference on a laser. The reference signal passes through a programmable gain amplifier. The main processor on Merlin controls the amplifier gain. Merlin provides intelligent range switching for best resolution with the 12 bit A/D. Reference channel filtering mimics the filtering of the main signal to ensure appropriate referencing. For higher resolution referencing or independent signal filtering you can add the full ratio option.

MENU FUNCTION KEYS

The high-resolution display is a 1/64 duty multiplexed Super Twist (Twisted Nematic) Liquid Crystal Display with 240 by 64 pixel and full dot matrix graphics capability. The clear 130 x 40 mm while on blue display fields is backlit by a cold cathode fluorescent lamp for a long life. The backlighting is fully adjustable.

MANU FUNCTION KEYS

Function keys allow rapid access to any item in the menu.

KEYPAD
 This 16 button keypad lets you enter the operating parameters and set the display contrast and brightness.

Figure 1: Hardware layout of the MERLIN™ Control Unit

II.2 INTENSITY MONITOR

We will start with a simple application of the MERLIN™ light measuring system to demonstrate initial system connections and menu selection process. The application involves monitoring the light intensity from a room lamp.

Components needed:

- 1 70100 series MERLIN™ unit;
- 1 one chopper, e.g. the 75152 enclosed chopper head with the 751 62 two-aperture chopper wheel;
- 1 detector head, e.g. the 70111 Silicon Detector.

Please make all the connections before turning the unit on.

Secure the chopper to your table. Attach the detector to the chopper with their mating flanges. Connect the chopper cable to the Chopper Motor socket and the detector cable to the Main socket in the back of the MERLIN™ unit.

Turn the unit on. Use the soft Arrow keys to select OPTIONS and then to move selector bar to FREQUENCY option and press SELECT key. Enter 30.0 Hz as a desired setting in 60 Hz power line countries (25.0 Hz in 50 Hz countries). Hit ACCEPT and then DONE keys. These particular chopper frequencies will provide good rejection of line frequency related intensity fluctuations. Use now the soft Arrow keys to move selector bar to CHOPPER option and press SELECT key. Move to ON+CAL setting and hit SELECT. This causes the MERLIN™ unit to start the chopper, determine the rotational constants of the chopper and then to settle at the requested chopping frequency.

Move now to FILTER option and hit SELECT. Choose 2 POLE filter and enter SELECT. This places you in the TIME CONSTANT sub-menu. Move between the time constants and note the changing effective bandwidth. This bandwidth is calculated for the type of filter you selected and will be different for the 1 POLE and 2 POLE filters. Choose .300 s setting and hit SELECT. Let's now ascertain that the PHASE option is set to the 2 PHASE setting and that INTERNAL SYNChronization is used (left as easily accomplished exercises to the user).'

Since MERLIN™ is an AC voltmeter, the default display units are in mV, the most typical signal level displayed. Moving to the NUCT PAGE, using leftmost soft key, select AUTORANGE and turn it ON. This will keep the display automatically optimized for different signal levels. Room lights should register a significant signal level on the detector and MERLIN™ will be displaying the voltage generated by the detector. Signal level should be in the nanovolt to volts range under most lighting conditions and with most load resistor selections on the detector. Signal level above 6 V will put the MERLIN™ system into nonlinear range of operation and are therefore signalled by 2 BIG display.

Let's now explore display modes. The center section of the LCD is called GRAPH, Fig.2, in this manual. It can contain menus, sub-menus, analog meter, or oscilloscope type displays. The default selection is the SCOPE which is reached as you scroll through the screens with the leftmost soft key. The upper and lower limits of the scope screen need to be defined for a meaningful display. Those limits are the same as for the analog output function and are set through the VOLTS OUT menu selection. For widely varying signals one could choose the LOG output type. However, since room lights should not be that variable, please choose the LINEAR scale. Choose the lower and upper signal levels for the SCOPE display and VOLTAGE OUT in the sub-menu of LINEAR SCALE of VOLTS OUT. We can choose -1.000 E-9 as the closest approximation to zero the system allows us to enter and set the upper limit to a value somewhat larger than the maximum light signal displayed in the upper left hand section of the display. As an example, an upper limit of 2.500 E-1 can be entered if the maximum signal observed was 210 mV. Hit DONE to exit back to the main menu.

NEXT PAGE soft key will allow us to scroll to the actual scope display. Blocking and unblocking the input to the chopper-detector assembly should result in the swings of the scope trace. The line should be fairly steady in the absence of people/objects motion in the room. Before we explore line frequency rejection vs. chopping frequency we will look at the customizing possibilities of the MERLIN™ system. Please notice the empty labels above three of the soft keys. They can be customized to your application. Hit OPTIONS and NEXT PAGE keys and then select SET MENU option. Use vertical arrow keys to bring FREQUENCY label above the second soft key. Move to the next label location with sideways soft key arrows and bring PAN/ZOOM in and then FREEZE into the last label location. Hit NEXT PAGE soft key twice to return to the scope display. Use the custom FREQUENCY soft key to explore signal stability vs. frequency. Try frequencies 1, 2, 3 Hz away from the 30 Hz (25Hz) initial setting and note the beat "noise" or in reality the real fluctuation of room lights at harmonics of line frequency. The original frequency setting, at sub-multiple of the line frequency, hid this fluctuation from us. It would do the same if we were to look for some other signals and room lights were the stray light we wanted to eliminate - chopping at sub-multiple of line frequency will provide the optimum filtering under most circumstances. You can use the FREEZE button to stop the writing of the scope trace to study some event at your leisure. The PAN/ZOOM button will be used when METER display replaces the SCOPE.

To change to METER display hit OPTIONS and then NEXT PAGE soft key and select GRAPH option. Choose METER and then scroll through menus until an analog meter display is seen. The sensitivity of the ten decade logarithmic display can be increased by using the PAN/ZOOM soft key. The scale can be expanded successively by factors of two (in decades) by the ZOOM soft key which also returns the display to the full, ten decade version. Sideways arrows can be used to center the indicator in the display. DONE selects the desired magnification.

II.3 CALIBRATED OPERATION

MERLIN™ can display not only simple voltage measurements but also calibrated readings in radiometric units. The detectors that Newport provides for use with MERLIN™ all come with a single point responsivity value which may be used to calculate incident power and display these readings in real time. Likewise, Newport also offers Calibration Modules for some MERLIN™ detectors so that accurate radiometric calculations can be done across a broad spectral range.

Because MERLIN™ is compatible with a wide variety of detectors, the exact procedure for obtaining calibrated results varies. Typically it is necessary to load wavelength and responsivity values into one of the Wavelength Tables, enter a Calibration Scale Number, and enter the wavelength you would like to measure. With these three steps MERLIN™ will readout accurate calibrated data in watts.

Please see the manual for your MERLIN™ Detector Head for detailed instructions calibrated operation of these detectors.

NOTE: Using MERLIN™ calibrated mode affects only the digital readout and does **not** affect the METER, SCOPE, or VOLTS OUT functions described later in this manual.

II.4 OPERATION IN A RATIO MODE

MERLIN™ system allows one to take readings in a ratio mode by providing a reference channel input. This serves to improve the accuracy of response measurements by removing the source variability. Any kind of detector can be used for reference as long as its signal level is compatible with the more limited dynamic range of the reference channel. Less than 6 V and significantly more than 0.18 mV signal level is desired for best operation. A BNC connector is provided which can be used in a grounded or floating mode, switch settable on the rear of the unit, whichever limits the noise the best.

Information on different menu options associated with the ratio modes are contained in the MENU SCREENS section of this manual.

II.5 COMPUTERIZED USAGE

COMMUNICATIONS TEST PROGRAM FOR MERLIN™

QBASIC VERSION FOR THE RS-232 BOARD

- Every version of Microsoft's MS-DOS® since v5.0 comes with QBasic. This version of the BASIC language supports high speed serial communications through your computer's COM1 or COM2 serial ports.
- Bring up QBasic® by typing: QBASIC (at the DOS prompt)
- In the main editing window, enter the following program. Make sure to substitute the COM port actually connected to MERLIN™ for COM2 on the sixth line
- Run the program. It will collect and display 100 readings from the meter and will then write a single column ASCII file MERLIN.DAT to your current working directory.

MERLIN.BAS file listing, below, demonstrates the use of the PRO (Procedure Zero) and TD (Take Data) statements to get data from the MERLIN™ system. These statements, the PD (Put Data) statement, and the addresses and values that are used to query or modify are listed in the COMPUTER CONTROLLED OPERATION OF MERLIN™ chapter of this manual.

MERLIN.BAS program listing:

```
' PROGRAM TO DEMONSTRATE DATA ACQUISITION FROM MERLIN
' AND TO SAVE DATA TO A DATA ARRAY AND TO A DISK FILE
CLEAR
OPTION BASE 0
Number% = 100
OPEN "COM2:96001N,8,1" FOR RANDOM AS #1
OPEN "Merlin.dat" FOR OUTPUT AS #2
DIM A AS STRING * 17
PRINT " MERLIN DATA:"
FOR i% = 1 TO Number%
    PRINT #1, "PR 0 \r"
    GET #1, 2, A
    PRINT #1, "TD 1 3 \r"
    GET #1, , A
    IF MID$(A, 7, 1) = "0" THEN Sign$ = "+" ELSE ESign$ = "-"
    IF MID$(A, 8, 1) = "0" THEN ESign$ = "+" ELSE ESign$ = " - "
    Exp$ = ESign$ + MID$(A, 9, 2)
    Man$ = Sign$ + MID$(A, 12, 1) + "." + MID$(A, 13, 3)
    Array (i) = VAL (Man$ + "E" + Exp$)
    PRINT Man$ + "E" + Exp$; " "
    PRINT #2, Man$ + "E" + Exp$
NEXT
CLOSE #1
CLOSE #2
END
```

III. MERLIN™ RADIOMETER DESCRIPTION

III.1 SYSTEM CONFIGURATION

The Merlin™ Radiometer is configured as shown by Figure 2. At its input port it accepts an A-C (chopped) signal from a detector (the main signal), amplifies and filters it, converts it into digital form and then demodulates it to give a digital D-C output signal. This signal, displayed on the front panel, is also available as an analog output voltage and may be transmitted to a computer by RS-232 or IEEE-488 link.

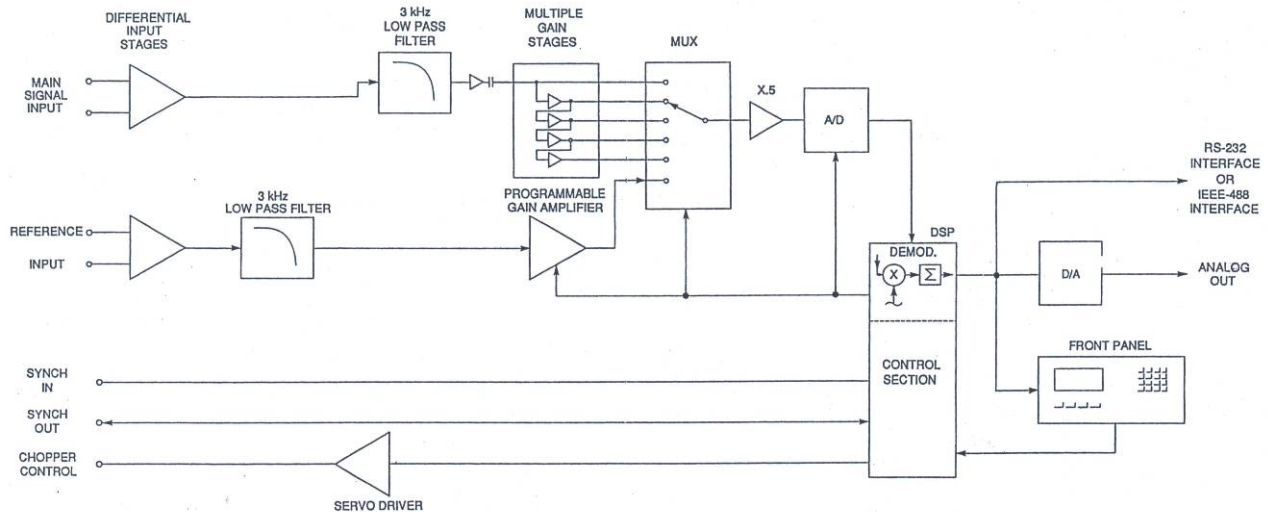

Figure 2: Signal Flow Diagram of MERLIN™ Radiometer

In addition to the main signal, a reference signal, which may be either D-C or A-C, is also filtered, amplified, converted and is then available for ratioing with the main signal following the demodulation process.

Besides these signals, a synchronizing (Sync) signal, generated either externally or internally, is used to synchronize the sine and cosine demodulation waveforms. The processing of these signals is now described in further detail.

Both the main and reference signals enter through differential amplifier stages which provide high (typically 11 Odb) of rejection to common mode signals. This insures that any off-ground voltages present at the detectors will have little effect on the true signals from the detectors. The high frequency noise accompanying the signals is removed by the 3 kHz low pass filters.

The main signal then passes through the multiple gain section where it is amplified in four stages, each having a gain of nine. The unamplified signal and the four amplified signals go to five inputs of the multiplexor (MUX). Each of these passes successively to the AID converter (ADC) and then to the digital signal processor (DSP). At the same time the reference signal passes through the programmable gain amplifier to the remaining multiplexor input and also to the ADC and DSP, insuring that the reference signal is processed in the same way as the main signal. The cycle times of the MUX and ADC are set by the DSP and are such that at least 13 full MUX cycles are completed during each chopper cycle when operating at the maximum chopping frequency. (At lower frequencies, $N \times 13$ MUX cycles will be completed where $N = 2, 4, 8, \text{etc.}$).

Thus each cycle of the main signal is sampled a minimum of 13 times at each of the five different gain levels. All these samples are stored in a buffer memory.

After each complete cycle the DSP compares the sampled main signal at each of the five gain levels and checks to see at which gain level, if any, the signal was saturated. Then the largest unsaturated level is noted for later use in the cycle.

The signals at each of the gain levels are multiplied, point-by-point, by synthesized cosine and sine waves which are synchronized by the sync signal from the chopper or from the internal sync generator (See Figure 3). The resulting products are summed and the end-of-cycle values, called the **correlation sums**, are stored in a series of memory locations. At the end of each cycle the correlation sums are multiplied by the appropriate gain equalization factors to put them all on the same gain basis. Since the results are floating point numbers this causes no reduction of the signal-to-noise ratio.

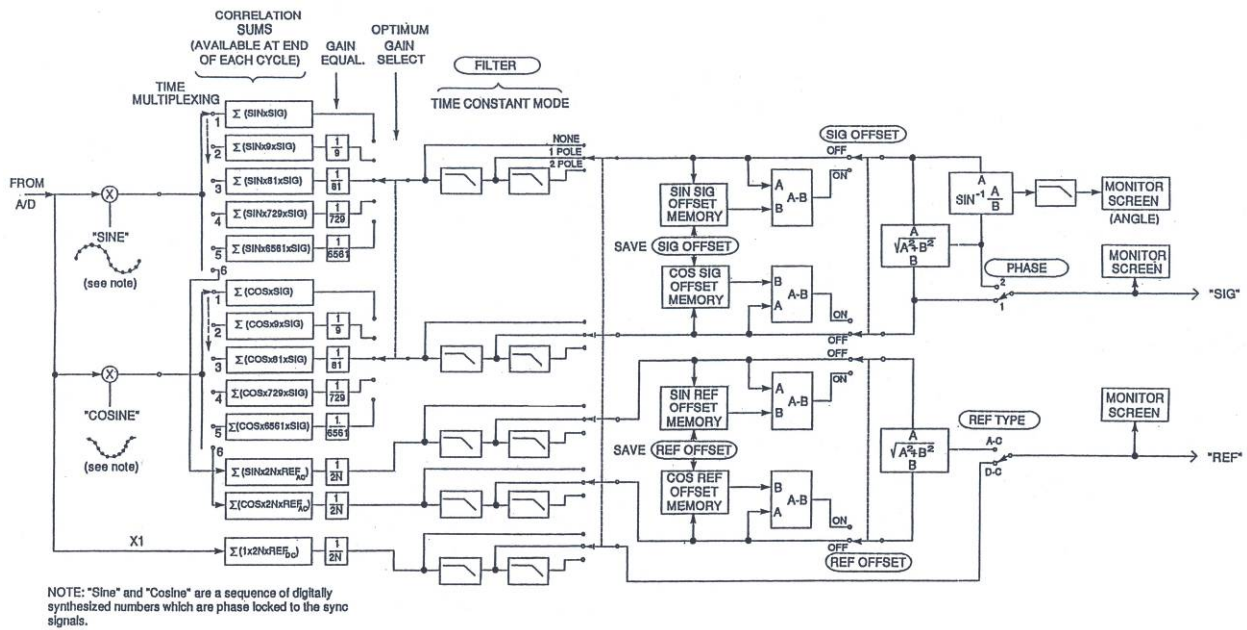

Figure 3: Digital Demodulation and Signal Processing in the DSP

The stored indication of the largest unsaturated gain level is now used to select the sine and cosine correlation sums. These values are then passed through a digital filtering section where they may be left unfiltered or, more typically, filtered by a one or two pole filter. The filtered signals are adjusted for any offset and then may be combined to give a magnitude (two phase) signal or a single phase signal with angle. The reference signal is processed similarly, except that only the magnitude is provided. Both the main signal (Sig) and reference signal (Ref), as well as the phase angle are available for further processing before being displayed on the monitor screen. The control of this processing is by means of on-screen menus which will be described later in Menu Screens section.

We now give an in-depth description of the operations occurring in each section of MERLIN™.

III.2 ANALOG SIGNAL PROCESSING SECTION

Analog signal processing in the Merlin™ is done on two boards: The Detector Interface Board and the Analog Signal Processor Board (see Figure 4).

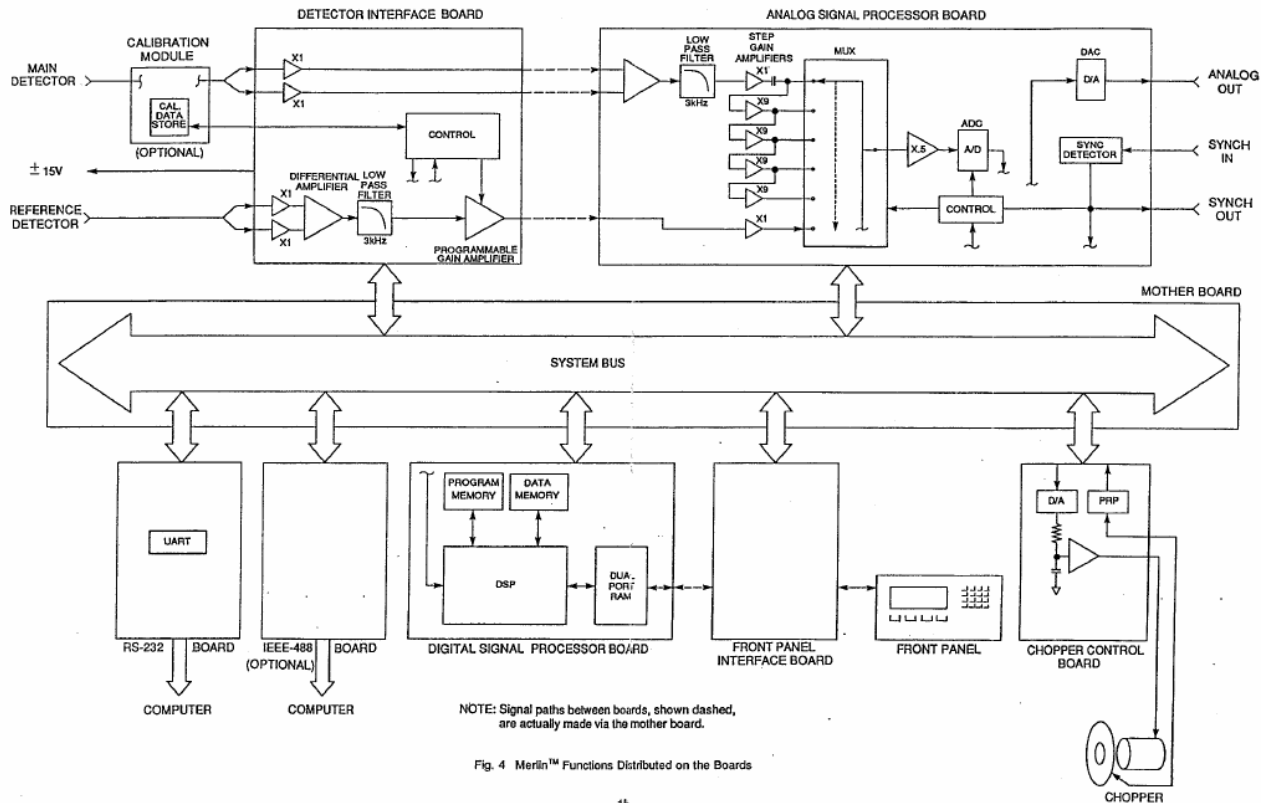

Figure 4: Merlin™ Functions Distributed on the Boards

The **Detector Interface Board** takes the main signal, either directly or through the calibration module and passes it through buffer amplifiers to a differential amplifier which provides about 110dB of common mode rejection.

The reference signal, which may be either d-c or chopped a-c, is similarly amplified and filtered through the selectable notch filter. A 3 kHz low pass filter is also in the path to eliminate aliasing problems, and finally a programmable gain amplifier brings the reference signal to a suitable level.

The optional **calibration module**, in addition to transmitting the main signal unchanged, has a PROM in which the calibration data for its detector is stored. This data consists of detector responsivity values at a number of wavelengths (up to 100). This data can be read out under control of the DSP when it is needed to convert the main detector's output into an irradiance value at any specific wavelength.

The amplified and filtered signals then pass to the **Analog Signal Processor Board**. The main signal goes through a 3 kHz low pass filter to the step gain amplifiers, while the reference signal goes directly to one of the MUX inputs. The MUX sequentially samples the main signal at each of the five gain levels and then the single level reference signal.

This simultaneous processing of the main signal at the five levels is the essence of the Smart Ranging™ feature which, unlike ordinary autoranging, provides an optimized signal level at all times. No time is lost while autoranging to the correct gain level.

The MUX outputs are attenuated by a 0.5 gain buffer before digital conversion in the ADC. The outputs from the ADC, a sequence of 12 bit numbers, are stored in a buffer memory before being transferred in groups to the Digital Signal Processor Board.

Other functions performed on the ASP Board are conversion of the processed signals to analog form by the DAC, the detection of the incoming sync signals and the output of sync signals generated by the DSP. The control of the MUX and ADC are mediated by a CONTROL module, which is in turn controlled by the DSP. The CONTROL module also produces the sync output signal.

NOTE: Signal paths between boards, shown dashed, are actually made via the motherboard.

III.3 DIGITAL SIGNAL PROCESSING

The digital signal from the ADC consists of a series of numbers which represent the values of the main signal at the various gain levels as well as the single level reference signal at various times during one chopper cycle. The signals are shown schematically in Figure 5. The waveform shown at the top is of the unamplified main signal which enters MUX Channel 1. The dots on the waveform indicate the times at which it will be sampled (read) by the ADC during the cycle. The number of readings shown, 13, is the smallest number that would be made during each cycle at the highest chopping frequencies; at lower frequencies multiples of this number of readings would be made.

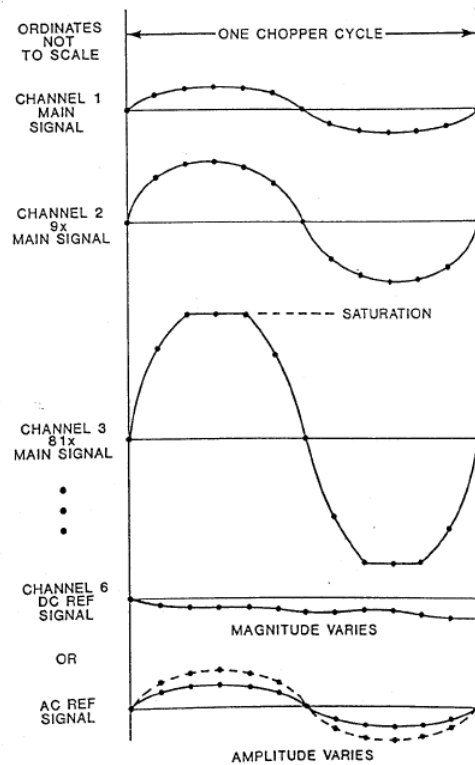

Figure 5: MUX Input Signals Showing A/D Conversion Points

The sequence of readings is of the first point in each waveform, channels 1 through 6, followed by the second point in each waveform, for all the channels and so on until all the points on all the channels are read. These readings are transferred in blocks from a buffer memory at the ADC's output to the DSP where they are processed.

The **Digital Signal Processing Board** holds a DSP module as well as various memory modules and logic blocks. The bulk of the data manipulation is done in the DSP. The more important operations are shown schematically in Figure 3. All of these operations are carried out digitally although some of them appear to be analog.

The first reading (number) of the data sequence goes to each of two multipliers. In one of these the number is multiplied by a corresponding number from a synthesized sine wave and in the other by the equivalent number from a synthesized cosine wave. The resulting products are transferred to two memory locations which are designated respectively on Fig. 3 as $\Sigma(\sin \times \text{sig})$ and $\Sigma(\cos \times \text{sig})$. The next point is multiplied by the same sine and cosine numbers and sent the $\Sigma(\sin \times 9 \text{ sig})$ and $\Sigma(\cos \times 9 \text{ sig})$ locations. This continues, point by point, until all six MUX signals have been multiplied and stored in this way. (An exception occurs if the reference signal is d-c; in this case it is simply multiplied by the gain of the programmable gain amplifier, 2^N . The a-c reference signals are multiplied by 2^N also, as well as by the sine and cosine numbers.)

The second set of six points is similarly processed by multiplying them by the next points one the sine and cosine waves and adding their products to the numbers already in the corresponding memories. This process continues until all the points for a complete chopper cycle have been processed and the products summed into their memories. These end-of-cycle sums are called correlation sums; they represent the demodulated signals at the various gain levels.

The correlation sums at each gain level are then divided by that gain to bring all the sums to the same relative gain (Gain Equalization). Then the largest unsaturated correlation sums are selected and passed on to the Time Constant section. Here the stream of sums are processed as if passing through a one or two pole filter. (The filter section may also be bypassed.)

The values of all the sine and cosine signals may also be saved and then subtracted from all subsequent sine and cosine readings; this allows any unwanted offset to be removed. Then the root mean square of the sine and cosine signals is taken, giving the **Two-phase** output signal. This is also termed a **magnitude** or **vector** output. Alternatively, the cosine signal alone gives the **One-phase** output signal. The phase angle between sine and magnitude signals is also computed and sent to the monitor screen.

In addition to these basic computations, the signals are processed in a variety of ways to yield other outputs. These are shown in MENU SCREENS section.

III.4 CHOPPER CONTROL

The Chopper Control Board provides for variable frequency control of Oriel 75154 Open and 751 52 Enclosed Chopper Heads. These choppers are driven by d-c motors, have interchangeable chopper wheels with 2, 5, 30 and 40 blades and have opt0 sensors which can be used for frequency control.

Chopping speeds up to 1 100 Hz can be selected from the menu. After a chopping frequency is selected, the DSP compares the actual frequency, as indicated by the pulses from the opto sensor, with the desired frequency. A digital correction signal is sent to the Chopper Control Board. This is converted to analog form and results in a motor drive signal to change the chopper speed. This process continues until the chopper is running at the selected frequency.

III.5 FRONT PANEL DISPLAY/KEY PAD/FUNCTION KEYS

The heart of the Merlin™ human interface capability is the display. This is a high resolution 240 x 60 pixel liquid crystal panel with full dot matrix graphics capability. It is controlled from the Front Panel Interface Board, which holds the logic for generating the various screens from data provided by the Digital Signal Processor.

The display consists of 4 distinct fields: the READOUT, MONITOR, GRAPH and MENU BAR. The READOUT (upper left) is a four-digit presentation of the desired measurement with a wide variety of formats. The MONITOR (upper right) can be used to present secondary information such as reference signal value or operating frequency. The GRAPH (center) is used to present a meter-like presentation of the main channel signal, display the menu selections, or a scope-like presentation of the analog output. The MENU BAR (bottom) presents the select options for that particular screen.

Shown below are two typical screens. The first presents the meter in the GRAPH region and the second replaces the meter with a typical menu screen.

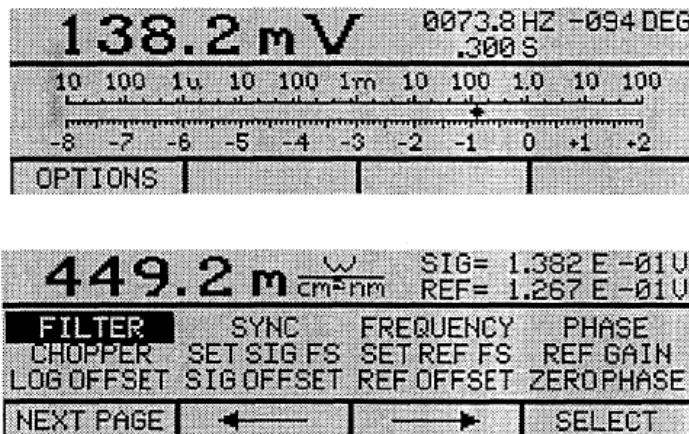

The menu function keys, Figure 1 are used to select the item/operation indicated on the menu bar directly above the key.

The keypad on the right side of the panel is used for entering numbers into the system. The right column of keys is used for adjusting the brightness and contrast of the display with simultaneous pressing of the desired key and either the up or down arrow.

A description of more of Merlin's menu screens is given in the MENU SCREENS section.

III.6 COMMUNICATIONS INTERFACE

The standard computer interface provided with Merlin™ is an RS-232 link on a separate **RS-232 Board**. It has selectable baud rates of 300, 1200, 2400, 4800 and 9600. It also allows for Even, Odd or No parity checking, 7 or 8 data bits per word and 1 or 2 stop bits per word. All these may be selected from the **COMPORT** menu screen.

The Merlin™ Serial Port has a DCE (Data Communication Equipment) configuration and, therefore, transmits data on pin 3 and receives data on pin 2 of the 25 pin D-sub miniature connector.

An **IEEE-488 Board** is an option replacing the RS-232 board in the Merlin™.

III.7 POWER SUPPLY

Merlin™ is powered by 115 V, 50-60 Hz or 230V, 50-60 Hz. Selection of the power line voltage is by means of a reversible link in the rear panel power entry module. The power switch is also located there. To change the line voltage selection; unplug the line cord and, with a small screw driver, remove the voltage select/fuse module from the power entry block. Pull out the voltage selector from the module. Rotate the selector until the correct line voltage is facing the module and re-insert the selector into the module. Replace the module in the power entry block.

IV. SPECIFICATIONS

SIGNAL CHANNEL

Frequency Range: 8 - 1100 Hz
 Sensitivity (referenced to input):
 LSB: 0.5 μ V
 Full Scale: \pm 6 V
 Input: Differential
 Common Mode Rejection Ratio: 110 dB
 Maximum Input Voltage \pm 15 V
 Input Noise: 60nV(Hz)^{-1/2} at 1 kHz
 Dynamic Reserve (for S/N = 100): 80 dB

RATIO CHANNEL

Sensitivity (referenced to input):
 LSB on A/D: 180 μ V
 Full Scale: \pm 6 V
 Input: Differential, grounded or floating
 CMRR: 95 dB
 Maximum Input Voltage: 15 V
 Input Noise: 12 μ V p-p in 3 kHz BW

INTERNAL FREQUENCY REFERENCE

Mode: Fundamental
 Phase Drift: None
 Orthogonality: 90° exactly
 Synchronizing Source: Internal or External

CHOPPER CONTROL

8 - 1100 Hz
 Closed loop servo
 Zero phase error
 8 s max slew time

DEMODULATOR

Operating Method: Input signal multiplied by digitally synthesized sine and cosine waves
 Signal Output: Single phase (Rcos Θ) yields amplitude & phase or Two phase (vector) yields magnitude.
 Time Constant: Chop period to 100S, single or two pole

OUTPUTS

Digital Panel Display: Digital presentation of one or two signals, in optical units. Chopping frequency, time constant, and phase angle.
 Log Meter: Shows signal level continuously.
 Analog Output: 0 to 10V; Log (IV/decade) or linear (programmable minimum and maximum)
 Digital Output: RS 232C standard; Data Rate to 9600 baud IEEE-488 optional (replaces RS-232)
 Synchronizing Output: TTL

GENERAL

Dimension: 11 1/8 x 14 1/8 x 5 1/4 inches (283 x 359 x 134 mm)
 Shipping Weight: 14 pounds (6.5 kg)
 Power: 95 - 130 VAC, 50 - 60 Hz
 190 - 260 VAC, 50 - 60 Hz (user selectable)
 Display Size: 5 x 1 3/8 inches (127 x 35 mm)
 240 x 64 pixels

V. CIRCUIT DESCRIPTION

V.1 ASP

The Analog Signal Processor (ASP) printed circuit board (pcb) receives the main signal and the reference signal from the Detector Interface pcb, processes these analog signals and converts them to digital format. Also located on the ASP pcb are BNC's for sync input, sync output, and analog output as well as their associated circuitry.

The BNC's on the ASP rear panel are:

TOP	Analog output voltage; 0 to 10 VDC, the significance is set through the VedUf menuselection.
CENTER	Sync output; TTL pulse occurring once every chop/instrument cycle.
BOOTOM	Sync input; any signal, amplitude > 100 mV & < 50 Vp-p, 8 - 11 OOHZ, to control operating frequency when external sync is selected.

V.2 DSP

The Digital Signal Processor (DSP) pcb is the heart of the Merlin™. The state of the art DSP chip located on this pcb provides the speed and computing power to both control the Merlin™ and perform all the mathematical operations required for demodulation and post-demodulation processing. The DSP pcb contains all the buffers and memory to support the DSP chip as well as a programmable logic device for synchronizing to the chopper or external sync signal.

The memory consists of 9K 24 bit words of program memory, 8.5K of 16 bit data RAM and 8K of nonvolatile data RAM where constants and set up information are stored. There is also dual port RAM which services the front panel through the front panel interface pcb.

There are no external connections to the DSP pcb.

V.3 CHOPPER CONTROL

The Chopper Control pcb incorporates a closed loop velocity servo that guarantees operation with zero phase error and quick slew response to speed commands (8 seconds min to max or max to min). The chopper rear panel contains a 10 pin (2 rows ,5 pins each) connector for connection to the Oriel Model 751 52, 75154 chopper motors.

V.4 DETECTOR LNTERFACE

The Detector Interface pcb provides connection, including power, to the main detector and buffers its output to the ASP pcb. The reference detector signal is connected through a BNC, buffered, passed through a differential amplifier, anti-alias filter and programmable gain amplifier also to the ASP pcb. On this board is the logic for reading out the optional calibration module and sending it to the DSP.

The 9-pin D-sub connects to the main detector (through the calibration module if used). The three test points (main signal high, main signal low and pcb ground) located above this connector permit access to the input signal lines for set up monitoring purposes; these points are connected directly to the input signal lines, care should be taken that any monitoring does not affect the true signal. The BNC is for the reference channel, the switch above the BNC selects whether the reference signal is floating or tied to the Merlin™ signal ground. At the bottom of the panel is a chassis ground which is different from the signal ground and may prove advantageous when shielding or ground loops enter the picture.

V.5 COMPUTER LNTERFACE

Each Merlin™ includes either an RS-232 serial interface card (Models 70100 and 70104) or an IEEE-488/GLIB interface card (Models 70103 and 70105). The Merlin computer interface card may be changed easily if desired.

The RS232 Interface pcb supports communication at baud rates from 300 to 9600, and full flexibility with respect to parity, and the number of data and stop bits. The rear panel connection is a 25 pin D-sub with transmitted data on pin 3 and received data on pin 2.

The IEEE-488 interface pcb is IEEE-488.1 compatible and supports data transfer at a much faster rate.

VI. MENU SCREENS

The menu screens provide front panel access to the powerful signal processing and set up capabilities that the Merlin™ makes possible. The menu keys, located below the display, are used for selecting menu items and the keypad is used for numeric data entry.

There are four primary level screens: the main screen, and three menu screens. The main screen provides the most measurement information while the menu screens are used for changing the instrument set up.

In the following discussion some of the menu screens, the shadowed text, e.g. **FILTER**, represents a menu item in the graph field, while bracketed text, e.g. [OPTIONS], indicates the selection of menu bar item by pressing the function key below that menu bar position.

THE MAIN SCREEN

The main screen, shown below, typically presents the meter in the graph area. The meter can be turned off or replaced by a scope type presentation (**GRAPH**). The readout, monitor and menu bar are not affected by the graph display. The empty positions on the menu bar may be filled with any of the menu items (**SETMENU**),

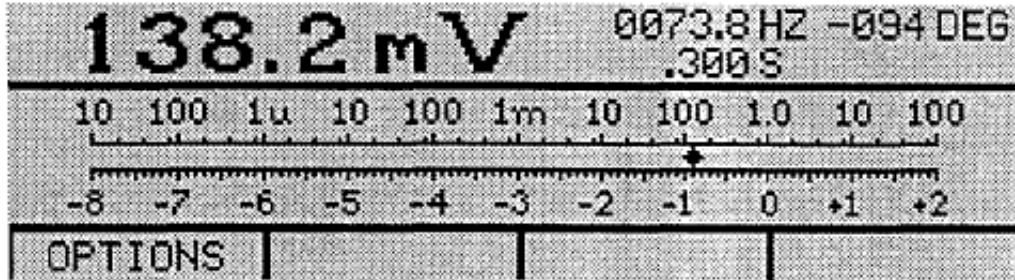

[OPTIONS] advances to menu screen # 1.

MENU SCREEN #1:

Menu screen #1 provides access to 12 menu items that are among the most frequently used. Any of these items may be included in the main screen by use of **SETMENU**. Menu screen # 1 is pictured below.

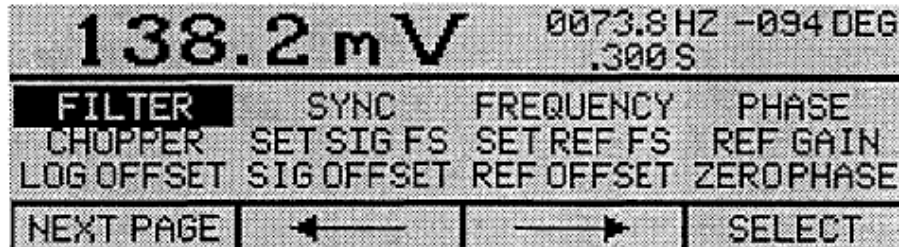

- [NEXT PAGE]** advances to menu screen # 2.
- [<--]** moves the highlight bar one item to the left.
- [-->]** moves the highlight bar one item to the right.
- [SELEC]** chooses highlighted item for modification/review.

FILTER

One of the major advantages of a chopped detection system is the capability of providing very narrow bandwidth filtering in order to reduce the effect of noise on a measurement. The narrower the bandwidth, the lower the noise (the noise being proportional to the square root of the bandwidth). However, the narrower the bandwidth the longer the response time and bandwidth selection is usually a compromise between reduced noise and longer response time. The Merlin™ eases this burden somewhat by presenting the selection in terms of both bandwidth and effective time constant. The Merlin™ filter selection runs the gamut from no filter, i.e. limited only by chopper frequency, to a time constant of 100 seconds. Single pole and two pole filters are selectable, the two pole filter providing faster roll off at the edges of the bandpass. The Merlin™ filters are implemented digitally and applied to both the main and reference signals.

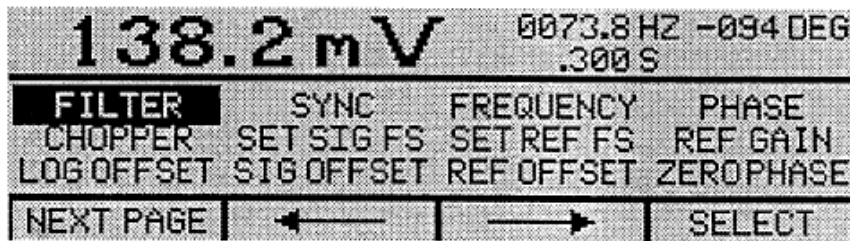

FILTER [SELECT] advances to the first filter screen.

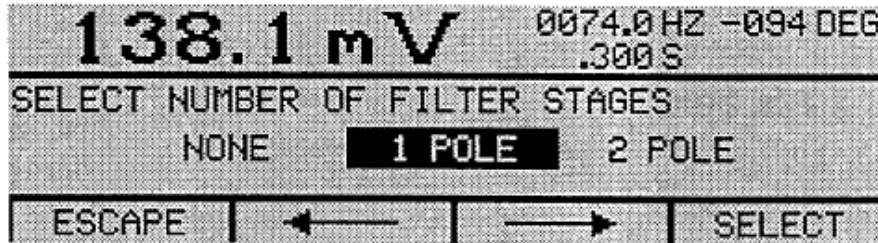

[ESCAPE] returns to menu #1, filter unchanged.

[<---] [--->] moves the highlight bar left/right.

NONE [SELECT] chooses no filter, returns to menu #1.

1 POLE at 2POLE [SELECT] chooses the highlighted filter type, brings up the time constant select screen.

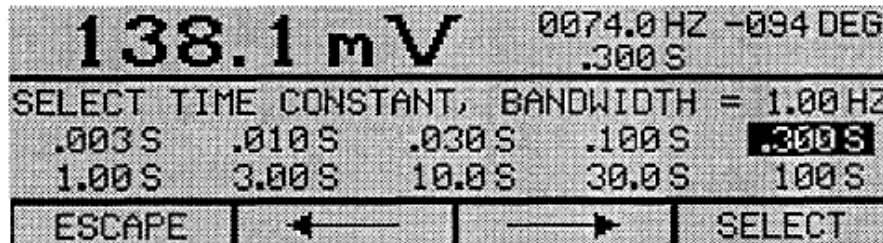

[ESCAPE] returns to menu # 1, filter unchanged.

[<---] [--->] moves the highlight bar left/right.

time constant [SELECT] chooses the filter time constant, returns to menu # 1. Note bandwidth indication in upper right corner of graph area.

SYNC

The synchronization source for establishing the Merlin™ operating frequency may be either internal or external. The external sync signal (>100 mV, 8 - 1 100Hz) is applied to the lower BNC on the rear panel of the ASP. If external sync is selected and no chopper is being used (the Merlin™ is being used as a synchronous AC voltmeter) the chopper must be turned off.

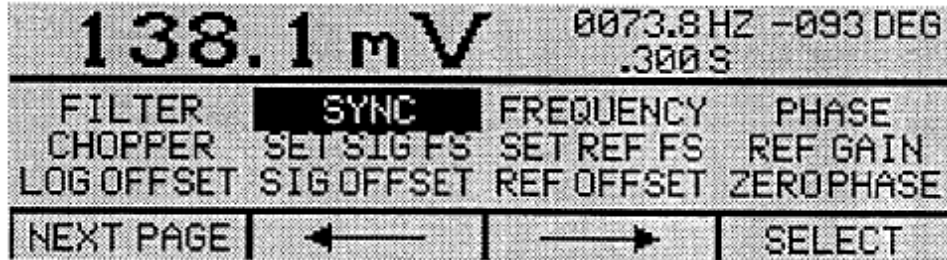

SYNC [SELECT] advances to the sync screen.

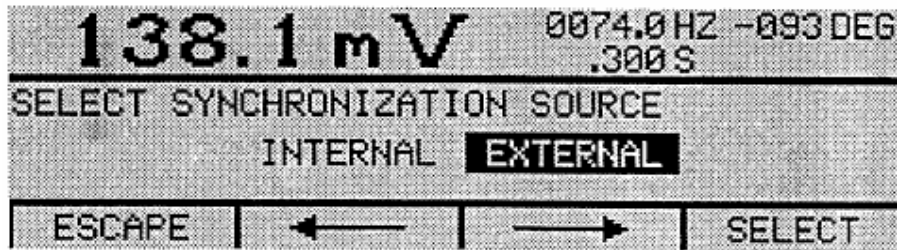

[ESCAPE] returns to menu # 1, sync unchanged.

[<---] [--->] moves the highlight bar left/right.

INTERNAL or EXTERNAL. [SELECT] chooses the highlighted synchronization source, returns to menu # 1.

FREQUENCY

This function sets the frequency for running on internal sync. The Merlin™ runs at any frequency from 8 to 1100Hz. However the Merlin™ chopper runs at a maximum of 100 revolutions per second so that the maximum operating frequency with the chopper is limited to 100N where N is the number of apertures in the chopper blade. Operation at frequencies higher than this limit may damage the chopper motor. Setting the frequency requires numeric entry. When the frequency screen is entered both a current setting and desired setting are displayed. At screen entry these numbers should be the same. Changes are made to the desired setting using the left/right arrows to position the cursor and either straight numeric entry or the up/down arrows for that digit. When satisfied, [ACCEPI makes this the current setting. The screen, however, is not left until [DONE] so that tweaking can be easily accomplished.

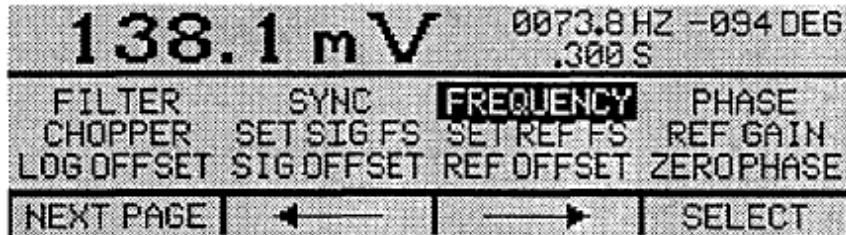

FREQUENCY [SELECT] advances to the frequency screen.

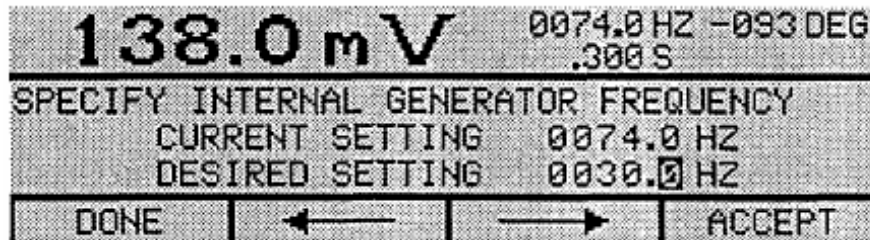

[ESCAPE] returns to menu # 1, frequency unchanged.

[<--] [-->] moves the cursor left/right one digit.

[ACCEP] moves desired value into current, advances to second frequency screen.

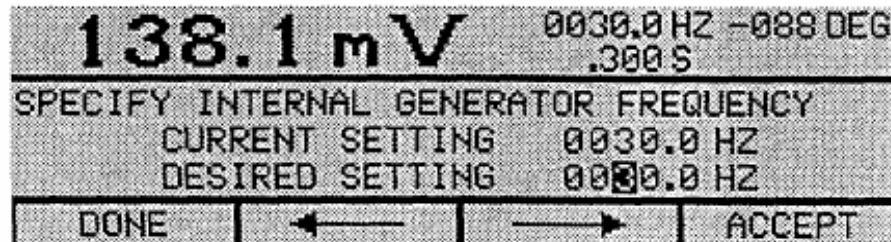

[DONE] returns to menu # 1.

[ACCEPT] moves desired value into current.

PHASE

The phase choices are two phase (or vector) which provides magnitude information and is insensitive to phase, or one phase ($R \cos\theta$) which provides amplitude and phase information but requires phase zeroing (aligning the input signal and the synthesized modulation wave) to achieve a true magnitude output. In general two phase processing is preferred, but for infrared measurements where negative numbers are significant one phase is more meaningful. In these cases it may be preferable to use one phase processing and **ZEROPHASE** on a robust signal.

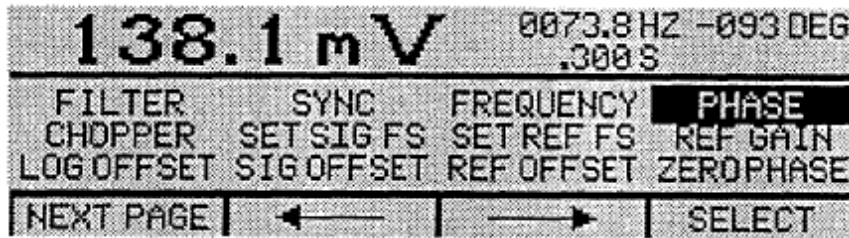

PHASE [SELECT] advances to the phase screen.

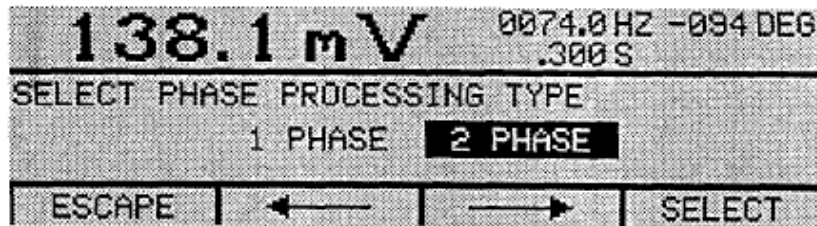

[ESCAPE] returns to menu # 1, phase unchanged.

[<---] [--->] moves the highlight bar left/right.

1 PHASE or 2 PHASE [SELECT] chooses the highlighted phase processing type, return to menu # 1.

CHOPPER

The chopper may be turned off or on from this screen. When a new chopper wheel has been installed or if there is some uncertainty about the chopper/wheel combination the on plus calibrate selection will result in the Merlin™ momentarily taking control of the chopper and determining the appropriate constants and then running the chopper at the predetermined frequency. If the chopper is selected on, the Merlin™ requires feedback from the chopper and will not run without it.

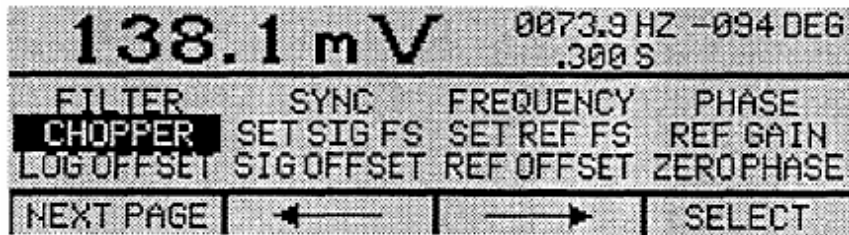

CHOPPER [SELECT] advances to the chopper screen.

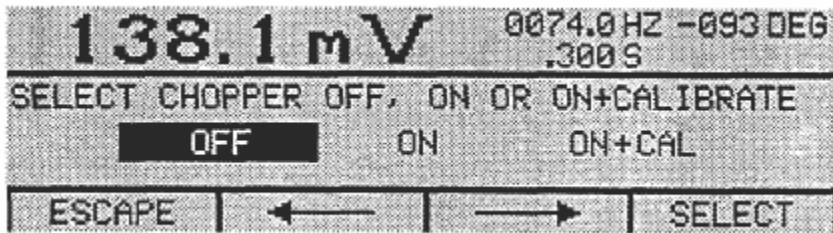

[ESCAPE] returns to menu # 1, chopper unchanged.

[<---] [--->] moves the highlight bar left/right.

chopper mode [SELECT] chooses the highlighted chopper mode, returns to menu # 1.

SET SIG FS

This function can be used to capture the main channel full scale. Having this value allows the Merlin™ to display the ratio of the present measurement to the captured full scale reading (**FACTOR**) either as a dimension-less constant or in dB format.

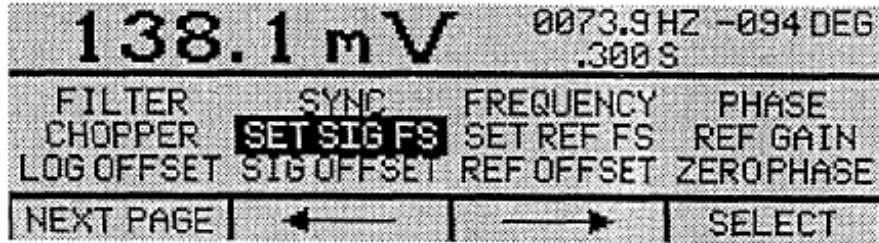

SET SIG FS [SELECT] advances to the FS capture screen.

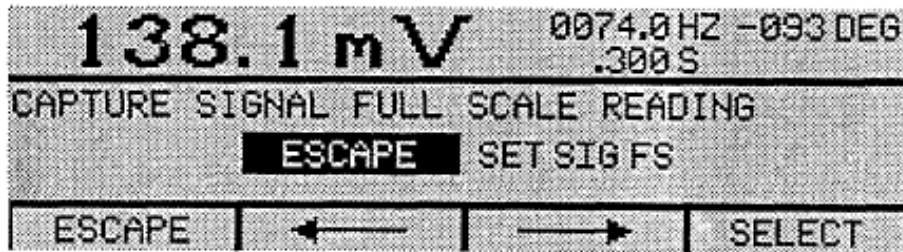

[ESCAPE] returns to menu # 1, stored value for main channel full scale unchanged.

[<---] [--->] moves the highlight bar left/right.

ESCAPE [SELECT] returns to menu # 1, stored value for main channel full scale unchanged.

SET SIG FS [SELECT] stores the current main channel reading as **SIG FS**, returns to menu # 1.

SET REF FS

The reference full scale signal is necessary to facilitate the analog output (**VOUT**) when operating in the ratio (main signal/reference signal) mode. In this mode the value presented is (main signal)*(reference full scale)/(reference signal). This scaling is necessary to keep the log output well behaved and is based on the assumption that the reference signal does not vary widely.

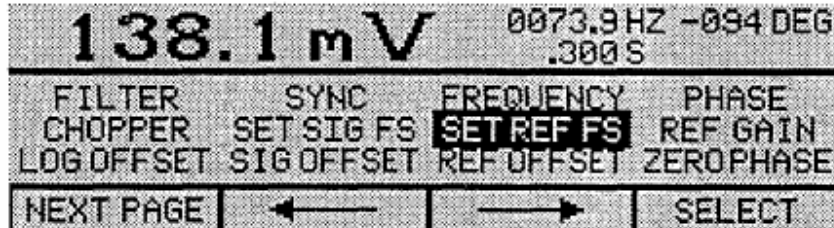

SET REF FS [SELECT] advances to the REF FS capture screen.

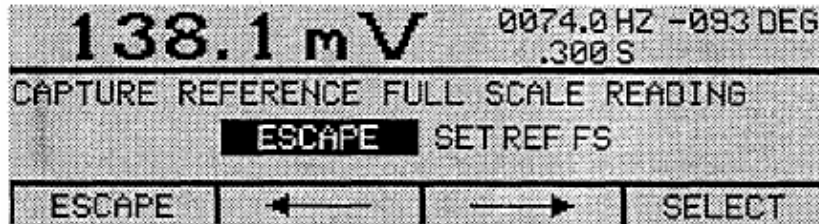

[ESCAPE] returns to menu #1, stored value for reference channel full scale unchanged.

[<---] [--->] moves the highlight bar left/right.

ESCAPE [SELECT] returns to menu #1, stored value for reference channel full scale unchanged.

SET SIG FS [SELECT] stores the current reference channel reading as REF FS, returns to menu # 1.

REF GAIN

The gain of the reference channel can be set to 1, 2, 4, 8 or 16. It is important that the gain be set to maximize the dynamic range of this signal. To keep this denominator term as stable as possible it is desirable to use as much gain as possible on this channel. This item is treated in a different manner from the rest. As the highlight bar is moved between gain selections, a percentage used is displayed in the upper right corner of the graph area indicating how much of the available range is being utilized, but the reference gain is not yet changed. Whenever possible the gain should be set make that usage approach 100% - some head room is advisable.

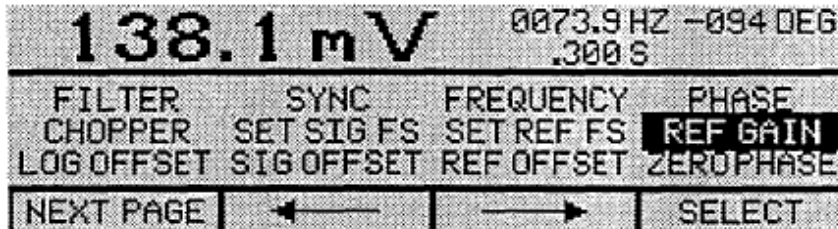

REF GAIN [SELECT] advances to the reference gain screen.

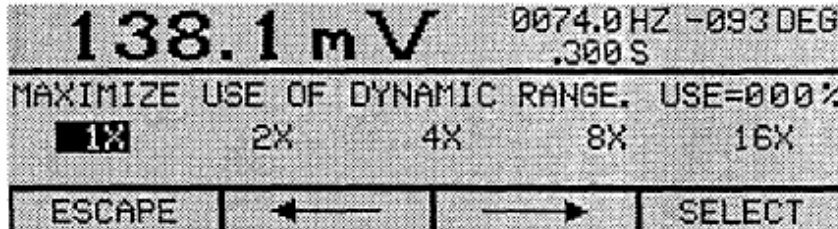

[ESCAPE] returns to menu #1, reference gain unchanged.
 [<---] [--->] moves the highlight bar left/right, provides a readout of dynamic range used.
 gain [SELECT] sets the value for the reference gain, returns to menu # 1.

LOG OFFSET

This menu selection stores an offset value which can be used when a logarithmic readout (**READOUT**) has been selected. It is often desirable to establish a value which other signals can be referenced to. The choices are to store the currently displayed value (and then subtract it from all subsequent readings), clear a previously stored log offset value, or change to dBm (power referenced to 1 mW, affixed offset of +30 dB with respect to the normal log readout) which requires both the log readout selection and units expressing power (units).

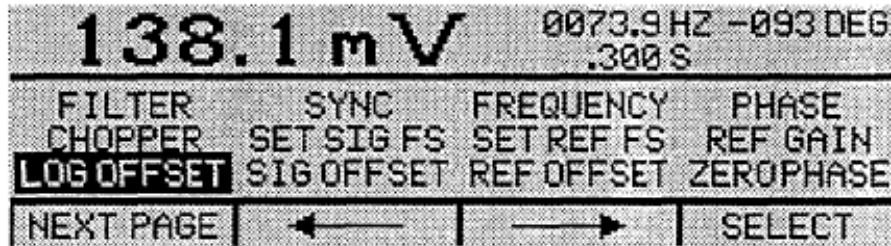

LOG OFFSET [SELECT] advances to the log offset capture screen.

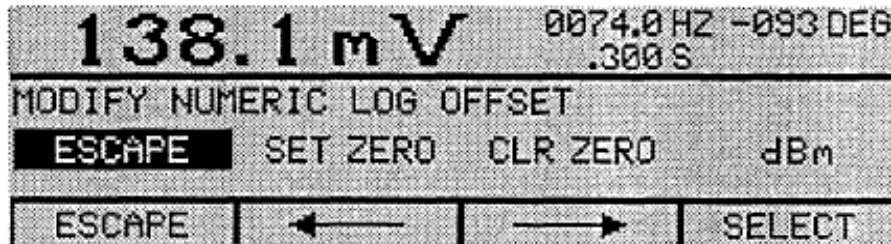

[ESCAPE] returns to menu #1, stored value for log offset unchanged.

[<---] [--->] moves the highlight bar left/right.

ESCAPE [SELECT] returns to menu #1, stored value for reference channel full scale unchanged.

SETZERO or CLR ZERO [SELECT] stores the current main channel reading as the log offset or clears

the old log offset value, returns to menu #1.

dBm [SELECT] chooses dBm readout, returns to menu #1.

SIG OFFSET

For relative measurements it is often desirable to establish a value from which signals can be offset. When not in the log mode, a main channel signal offset value can be stored or cleared. This signal offset value is subtracted from subsequent main channel readings.

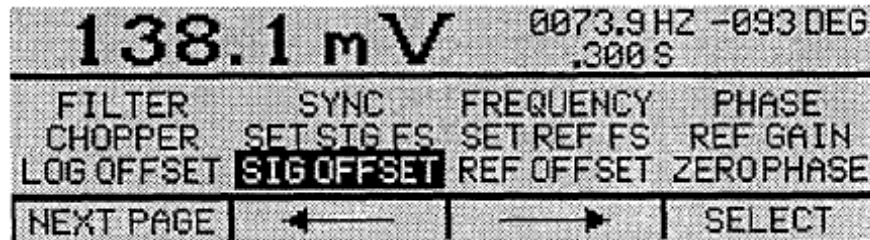

SIC3 OFFSET [SELECT] advances to the signal offset capture screen.

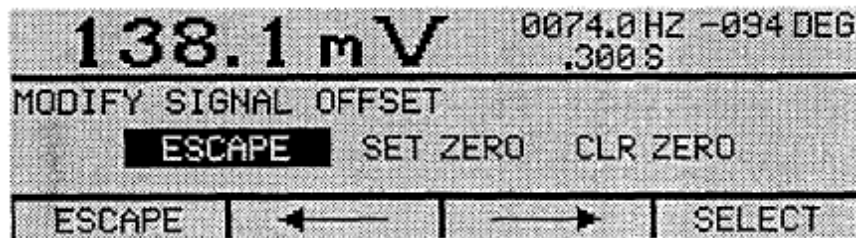

[ESCAPE] returns to menu # 1, stored value for main signal offset unchanged.

[<--] [-->] moves the highlight bar left/right.

ESCAPE [SELECT] returns to menu # 1, stored value for signal offset unchanged.

SET ZERO or **CLR ZERO [SELECT]** stores the current main channel reading as the signal offset or clears the old signal offset value, returns to menu # 1.

REF OFFSET

For relative measurements it is often desirable to establish a value from which signals can be offset. When not in the log mode, a reference channel signal offset value can be stored or cleared. This signal offset value is subtracted from subsequent reference channel readings.

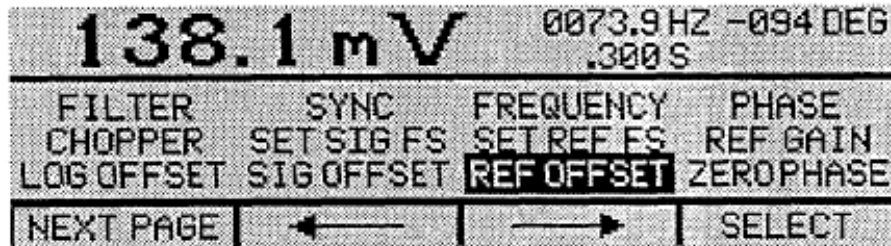

REF OFFSET [SELECT] advances to the reference offset capture screen.

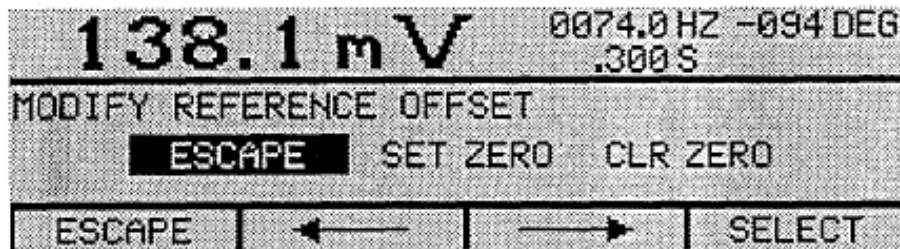

[ESCAPE] returns to menu # 1, stored value for reference signal offset unchanged.

[<--] [-->] moves the highlight bar left/right.

ESCAPE [SELECT] returns to menu # 1, stored value for reference signal offset unchanged.

SET ZERO or CLR ZERO [SELECT] stores the current reference channel reading as the reference signal offset or clears the old reference signal offset value, returns to menu # 1.

ZEROPHASE

In the one phase processing mode the maximum amplitude readout is obtained only when the input signal and the synthesized modulating wave are in phase. Zeroing the phase, which is best done on strong signal, accomplishes this alignment. With two phase processing phase zeroing has no significance.

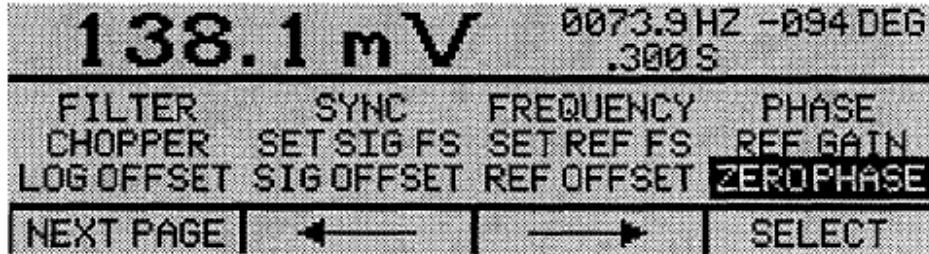

ZEROPHASE [SELECT] advances to the phase zeroing screen.

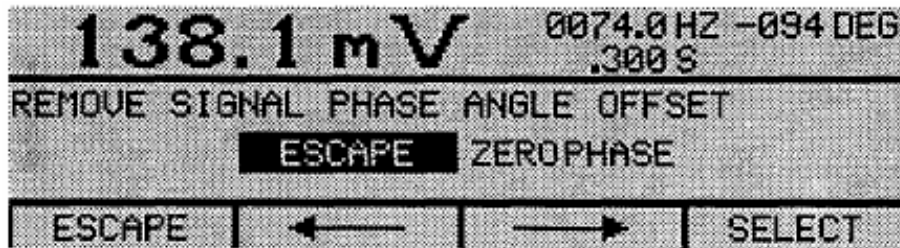

[ESCAPE] returns to menu # 1, stored value for phase offset unchanged.

[<---] [--->] moves the highlight bar left/right.

ESCAPE [SELECT] returns to menu # 1, stored value for phase offset unchanged.

ZEROPHASE [SELECT] stores the current phase angle reading, returns to menu # 1

MENU SCREEN #2 :

Menu screen #2 provides access to 12 more menu items. Any of these items may be included in the main screen by use of **SETMENU**. Menu screen #2 is pictured below.

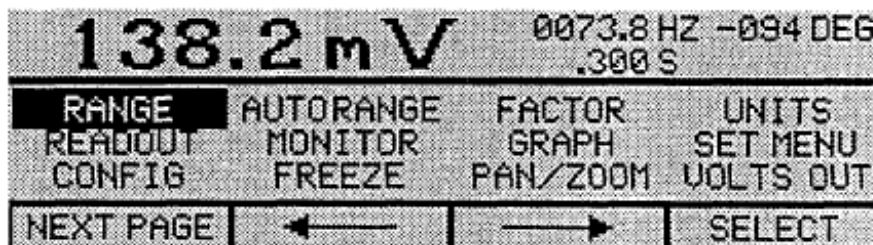

- [NEXT PAGE]** advances to menu screen #3.
- [<---]** moves the highlight bar one item to the left.
- [--->]** moves the highlight bar one item to the right.
- [SELECT]** chooses highlighted item for modification/review.

RANGE

For fixed range applications both the range selection and the numeric format are selected through this menu item. Range choices range from femto (f) to tetra (T) while the format for the four digit numeric display allows 1,2, or 3 digits to the left of the decimal point. Selecting a fixed range format terminates autorange operation.

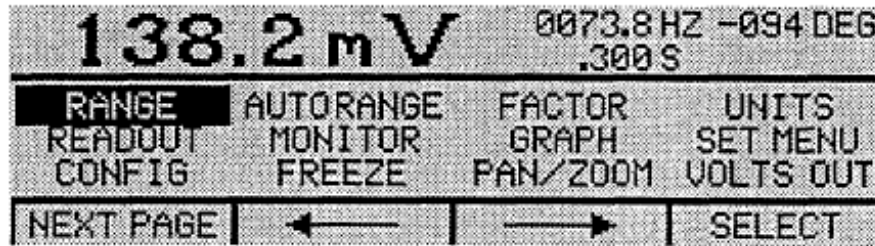

RANGE [SELECT] advances to the first range selection screen.

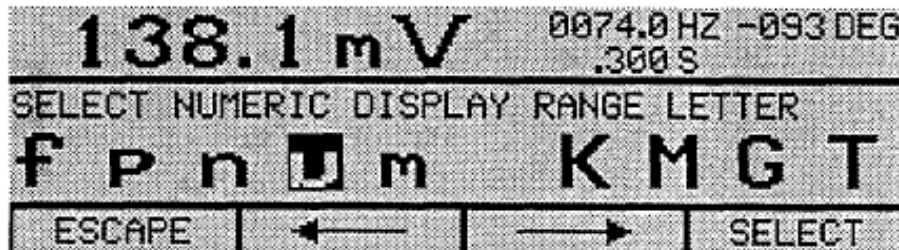

[ESCAPE] returns to menu #2, range letter unchanged.

[<--] [-->] moves the highlight bar left/right.

letter [SELECT] chooses the highlighted fixed range multiplier, advances to second range screen.

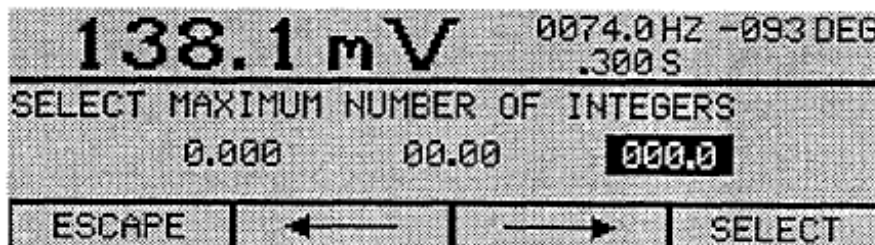

[ESCAPE] returns to menu #2, range letter and numeric format unchanged.

[<--] [-->] moves the highlight bar left/right. **0.000 or 00.00 or 000.0 [SELECT]** chooses the fixed range multiplier, returns to menu #2.

AUTORANGE

When autorange is enabled the fixed range selections are overridden and the readout will optimize the number of significant digits displayed. The actual format depends on readout display type (READOUT):

Scientific	x.xxxE±yy
Engineering	x.xxx or xx.xx or xxx.x as required
Log	xx.xx dB

Autorange is a display function and does not affect the Smart Range™ feature.

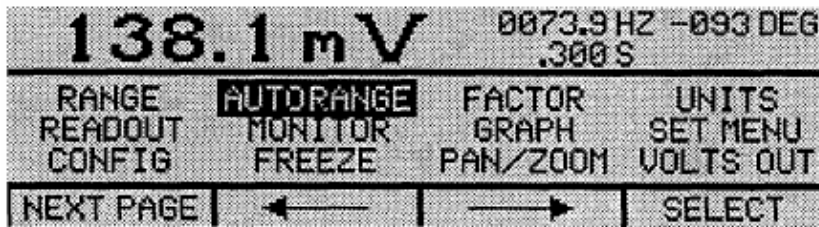

AUTORANGE [SELECT] advances to autorange select screen.

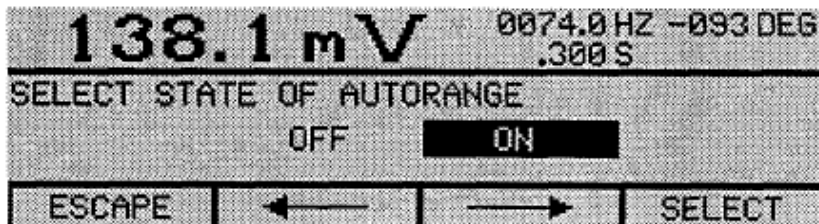

[ESCAPE] returns to menu #2, range choice unchanged.

[<--] [-->] moves the highlight bar left/right.

OFF or ON [SELECT] chooses the highlighted state, returns to menu #2.

FACTOR

This selection defines the type of signal multiplier to be used. Depending on factors selected, sensitivity and spectral variation, displayed values are governed by one of the following equations.

$$\text{Output1} = (K/K_x) * (\text{signal} - \text{signal offset})$$

$$\text{Output2} = \{(\log_{10} \text{output1}) - \log \text{offset}\} * (10 \text{ or } 20)$$

(power or voltage)

$$\text{Output3} = (1/K_x) * \{(\text{signal} - \text{signal offset}) / (\text{ref} - \text{ref offset})\}$$

$$\text{Output4} = \{(\log_{10}, \text{output3}) - \log \text{offset}\} * 20$$

$$\text{Output5} = (\text{signal} - \text{signal offset}) / \text{signal full scale}$$

$$\text{Output6} = \{(\log_{10} \text{output5}) - \log \text{offset}\} * 20$$

Where: Output1 and output2 use the K (**UNITS**, calibration scale number) multiplier, K (**WAVELEN**) and signal offset (**SIG OFFSET**); additionally output2 uses log offset (**LOG OFFSET**) and log display (**READOUT**). Output3 and output4 use the 1/REF multiplier and bring in the reference signal (**REF TYPE**, **REF GAIN**) and reference offset (**REF OFFSET**). Output5 and output6 use the 1/SIG FS multiplier and introduce signal full scale (**GET SIG FS**).

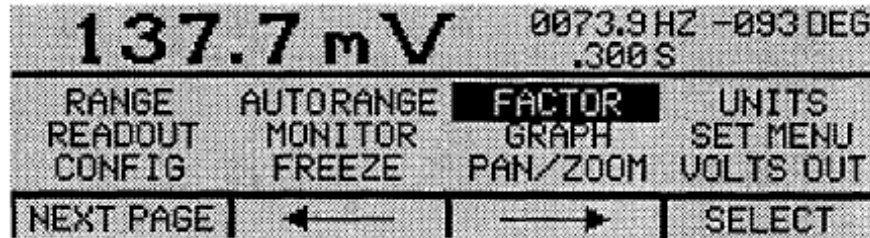

FACTOR [**SELECT**] advances to the factor selection screen.



[**ESCAPE**] returns to menu #2, factor choice unchanged.

[<---] [--->] moves the highlight bar left/right.

multiplier [**SELECT**] chooses the highlighted multiplier, returns to menu #2.

UNITS

Use this menu item to select the appropriate units for display. The Merlin™ is a synchronous voltmeter and therefore only measures volts. Appropriate scale factors must be entered to convert the measured voltage to other units. The second screen provides the ability to enter one of these constants, the calibration scale factor which directly multiplies the signal value. The other constant is wavelength response constant, K_{λ} , which is available through the **WAVE LEN** choice.

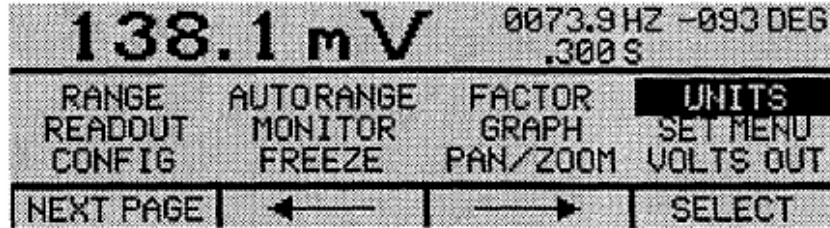

UNIT3 [SELECT] advances to unit select screen.

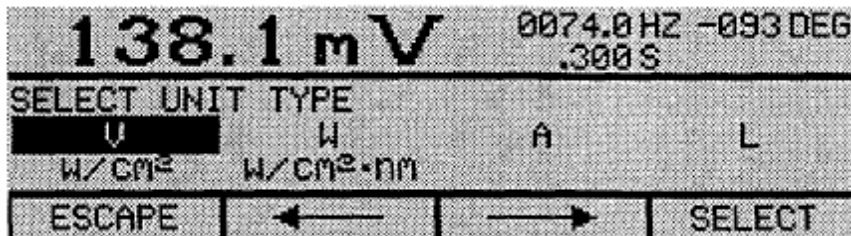

[ESCAPE] returns to menu #2, units unchanged.

[<--] [-->] moves the highlight bar left/right.

unit type [SELECT] chooses the highlighted unit, advances to second unit screen.

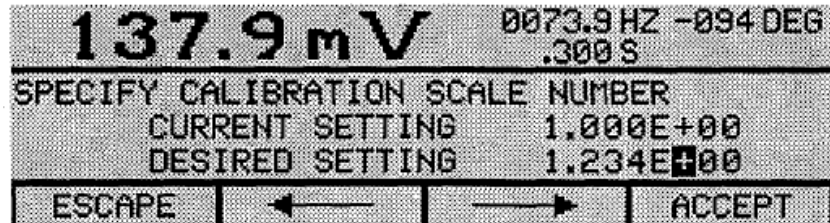

[ESCAPE] returns to menu #2, units unchanged.

[<--] [-->] moves the cursor left/right one digit on desired setting, numeric keys and/or up down arrows modify digit.

[ACCEPT] moves desired to current setting, advances to third units screen.

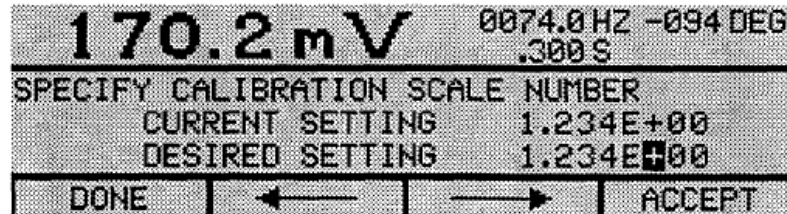

[ESCAPE] returns to menu #2, units and constant changed.

[<--] [-->] moves the cursor left/right one digit on desired setting, numeric keys and/or up down arrows modify digit.

[ACCEPT] moves desired to current setting.

[DONE] returns to menu #2.

MONITOR

The monitor field is located at the upper right of the display. The three choices for monitor are:

- NONE - which leaves the field blank.
- PARAMETER - which shows operating frequency, phase angle, filter time constant, selected wavelength with the respective fields blanked if feature not invoked.
- SIG/REF - which displays values for main channel signal and reference channel signal with offsets removed but prior to other modifications, e.g. constants or logarithmic action.

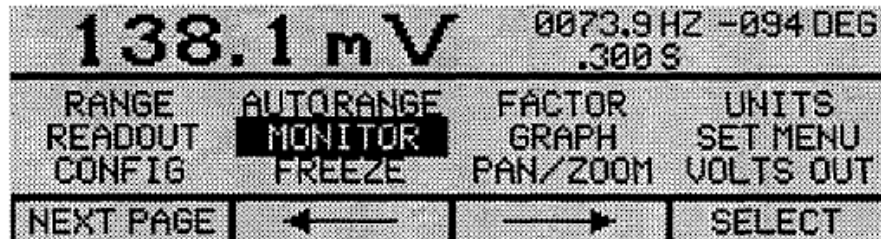

MONITOR [SELECT] advances to the monitor screen.

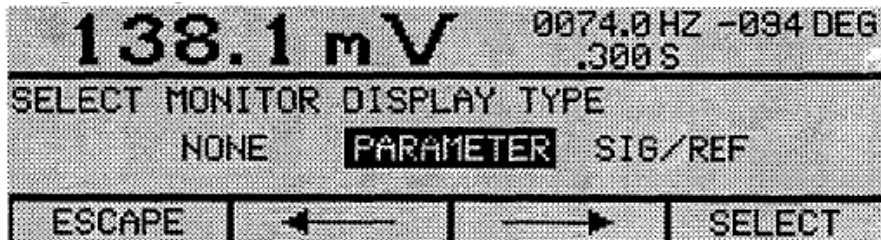

[ESCAPE] returns to menu #2, monitor field unchanged.

[<--] [-->] moves the highlight bar left/right.

monitor type [SELECT] chooses the highlighted monitor type, returns to menu #2.

GRAPH

The graph section of the screen can either be empty, display the log meter (10 decades zoom-able in four steps to 1-118 decades), or a scope type display that depicts the analog output voltage for purposes of system trouble shooting.



GRAPH [SELECT] advances to the graph selection screen.



[ESCAPE] returns to menu #2, graph field unchanged.

[<--] [-->] moves the highlight bar left/right.

monitor type [SELECT] chooses the highlighted graph type, returns to menu #2.

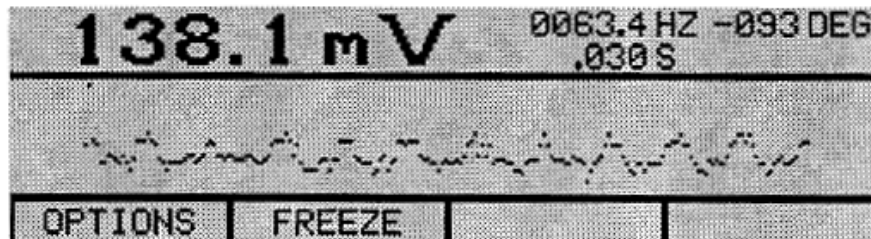

A typical scope presentation showing periodicity of output signal.

Note: Upper and lower limits of SCOPE display are the same as those set in VOLTS OUT.

SET MENU

The three empty boxes on the main screen menu bar may be set to provide direct access to any of the menu items. Regularly used items - perhaps **PAN/ZOOM** can then be accessed without having to step through the menu screens. These menu bar selections may be changed at any time.

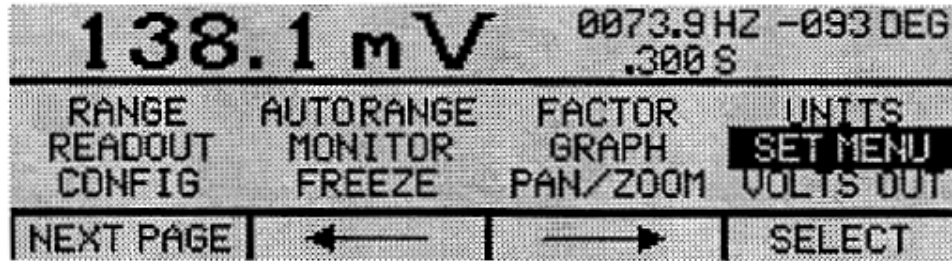

SET MENU [SELECT] advances to the set menu screen.

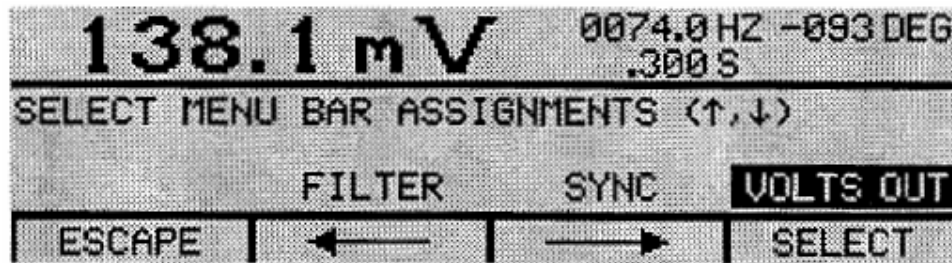

[ESCAPE] returns to menu #2, menu bar fields unchanged.

[<---] [--->] moves the highlight bar left/right. The three positions show the menu selection chosen for that menu bar location. The keypad up/down arrows are used to scroll through the menu items. **menu item 1 menu item 2, menu item 3 [SELECT]** chooses the items selected as main screen menu bar items, returns to menu #2.

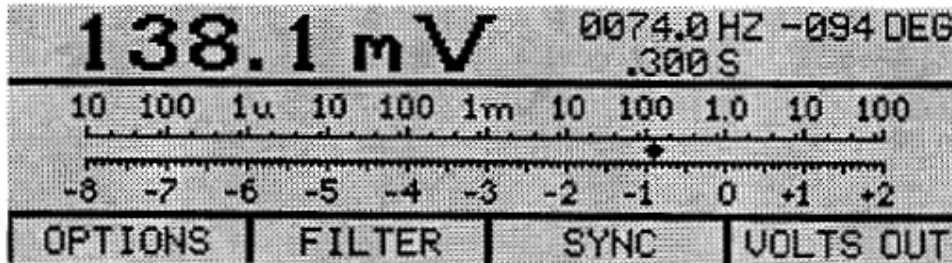

A sample main screen with filled menu bar.

CONFIG

At power up the DSP queries the modules in the system. The configuration screen reports the result. A typical system would have a communication board in slot 1, chopper motor control in slot 2, analog signal processor in slot 5 and a detector interface card in slot 6. No action associated with this screen.

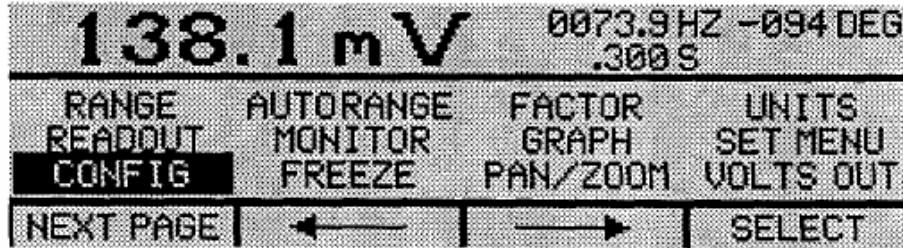

CONFIG [SELECT] advances to the configuration screen.

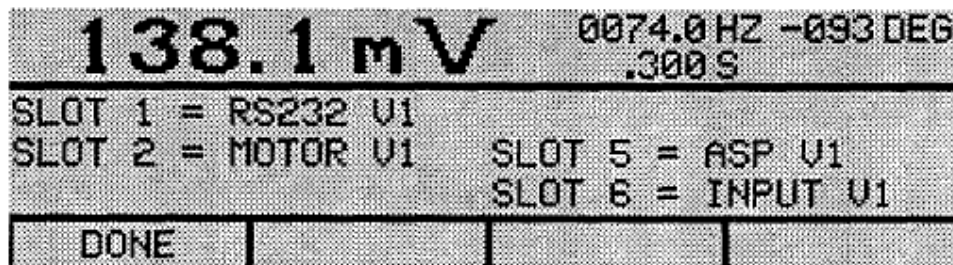

[DONE] returns to menu #2.

FREEZE

Freeze is associated only with the scope graph display and as such is best utilized as a main screen menu bar selection on the main screen. Selecting the freeze option alternately freezes and unfreezes the scope presentation. There is no separate freeze screen.

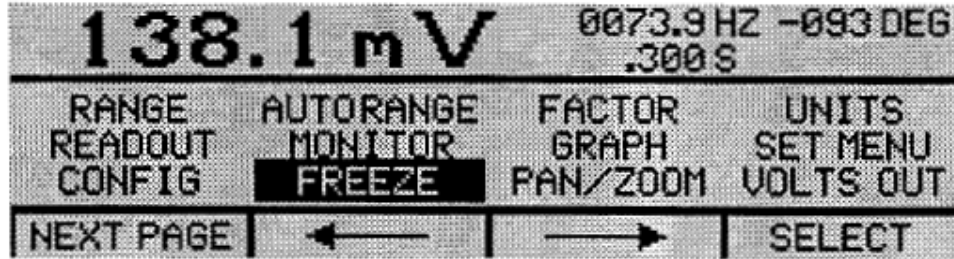

FREEZE [SELEC] alternately freezes and unfreezes the scope display. The menu screen does not change.

PAN/ZOOM

The pan and zoom features affect only the meter graph display. Successive zoom selections provide three steps of 2 to 1 zooming and then a return to the 10 decade display. The pan selection moves the zoomed meter by a decade.

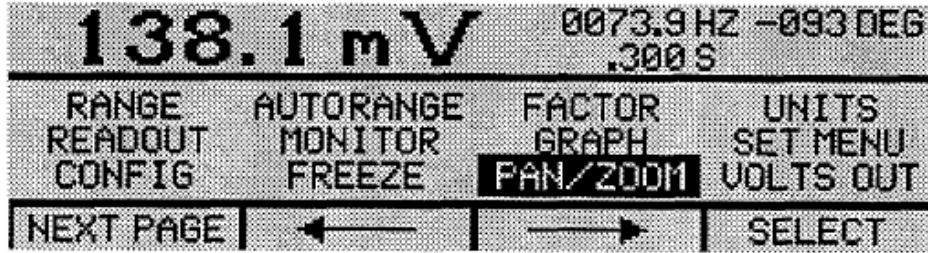

PAN/ZOOM [SELECT] displays the meter with the pan/zoom menu bar.

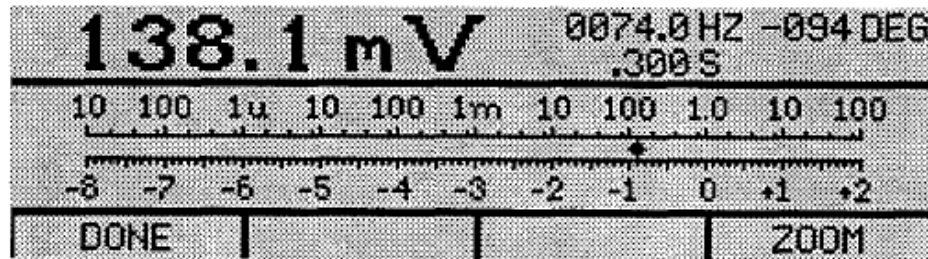

[ZOOM] expands the meter scale by 2 and brings up pan arrows.

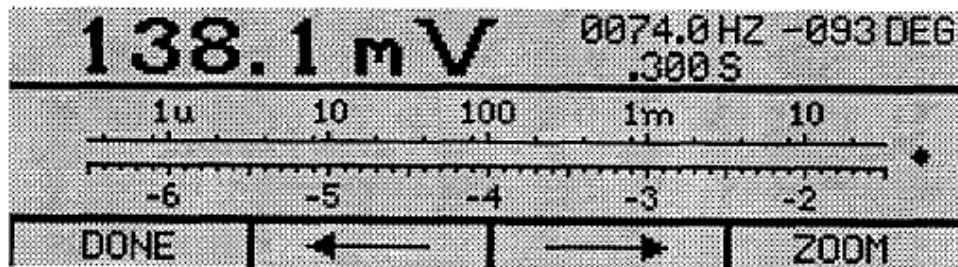

[-->] slides the meter scale one decade right.

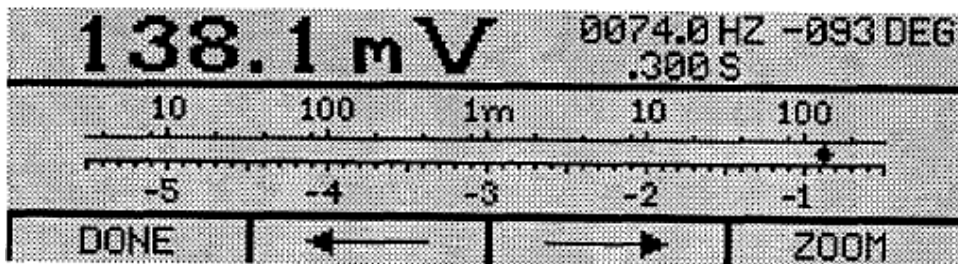

[-->] slides the meter scale one decade right again.

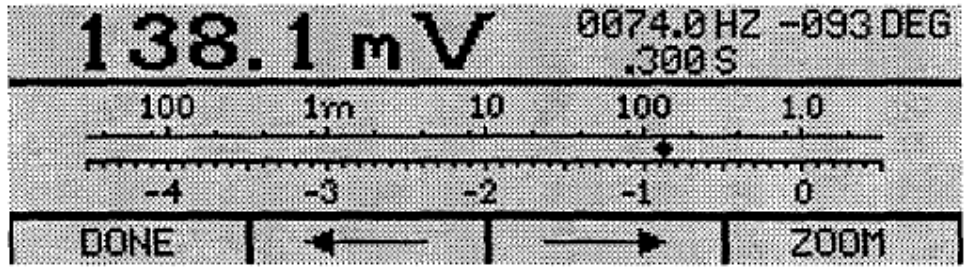

[ZOOM] expands the meter scale by 2 again.

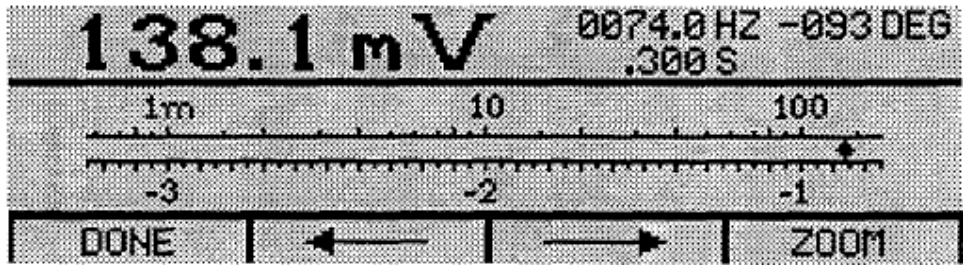

[-->] slides the meter scale one decade right again.

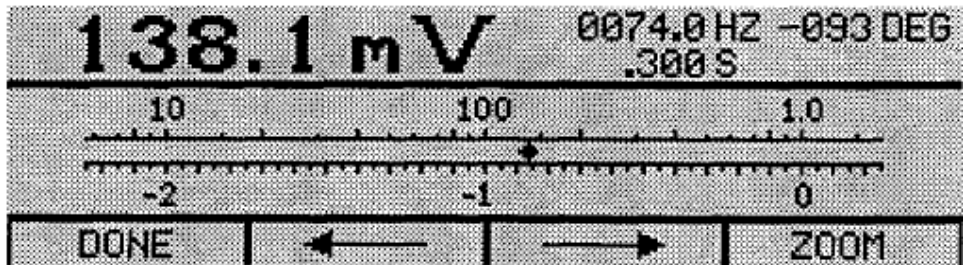

[ZOOM] expands the meter scale by 2 again (see next page).

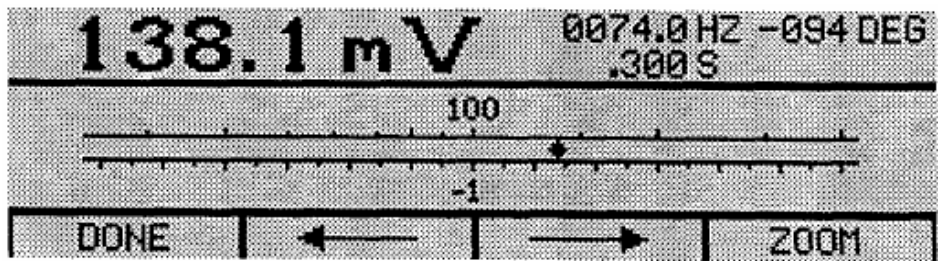

[DONE] saves meter set up, returns to menu #2.

[ZOOM] returns to un-zoomed meter, stays in pan/zoom mode.

VOLTS OUT

The analog output available on the top BNC of the ASP board is set up using this selection. The choices are:

- OFF set zero volts out.
- LINEAR linear output, 0 to 10 VDC with the ability to set the range as desired.
- LOG logarithmic output, 0 to 10 VDC with 1 volt/decade.



VOLTS OUT [SELECT] advances to the output voltage type screen.

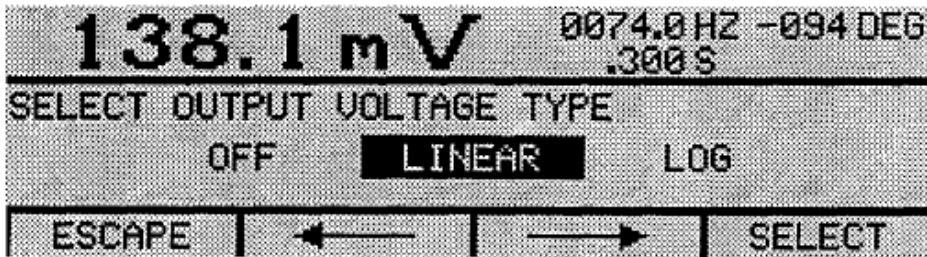

- [ESCAPE]** returns to menu #2, output voltage unchanged.
- [<--] [-->]** moves the highlight bar left/right.
- OFF or LOG [SELECT]** chooses the item highlighted, returns to menu #2.
- LINEAR [SELECT]** chooses linear output, advances to output voltage set screen.

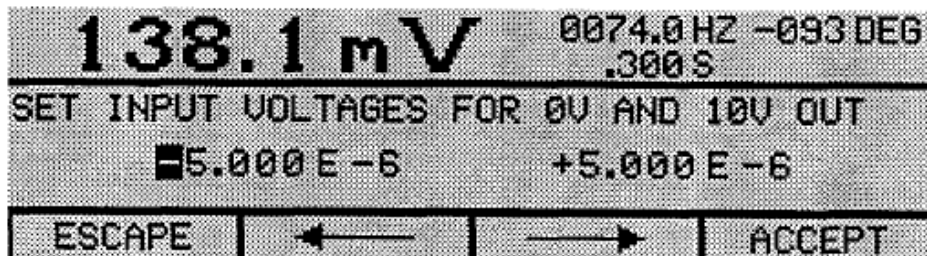

- [ESCAPE]** returns to menu #2, output voltage unchanged.
- [<--] [-->]** moves the highlight bar left/right one digit.
- [ACCEP]** sets 0 V out equal to left field, 10 V out equal to the right field.

WAVELENGTH

Selects a wavelength and its related normalized response from the current wavelength table (TABLE). The response value is used as K, in the final signal calculation. As long as the selected wavelength is within the range of the current table, a response will be calculated. Wavelength values up to 29,999 nm can be processed.

The selected wavelength value is shown in the monitor field when **PARAMETER** is chosen.

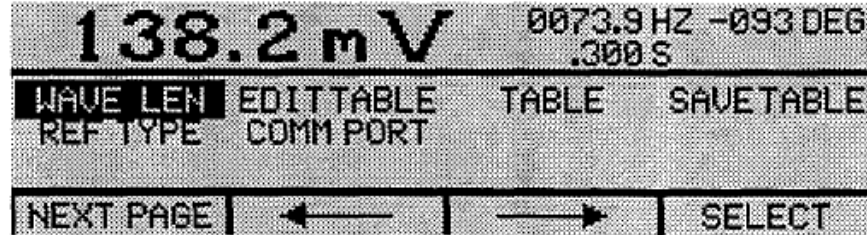

WAVELEN [SELECT] advances to the wavelength select screen.

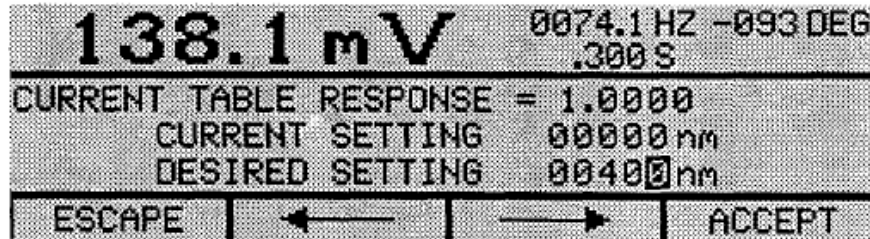

[ESCAPE] returns to menu #3, no change to wavelength selection.

[<--] **[-->]** move cursor left/right one digit. The number keys and/or the keypad up/down arrows are used to modify the wavelength digits.

WAVELENGTH [ACCEPT] makes the desired setting the current setting, generates a response number and divides signal by response number to normalize for wavelength variations.

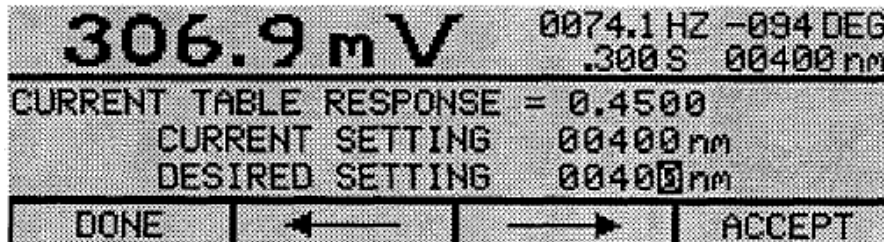

[DONE] returns to menu #3, with new wavelength selection.

[<--] **[-->]** move cursor left/right one digit. The number keys and/or the keypad up/down arrows are used to modify the wavelength digits.

wavelength [ACCEPT] makes the desired setting the current setting, generates a response number and divides signal by response number to normalize for wavelength variations.

EDIT TABLE

An existing wavelength table can be modified or a new table entered manually. Up to 100 points are permitted with wavelengths from 1 to 29,999 nm allowed. Table entries are ordered by wavelength and new entries or modifications must conform to this structure. The 00 point cannot be altered, selecting it effectively bypasses the wavelength table.

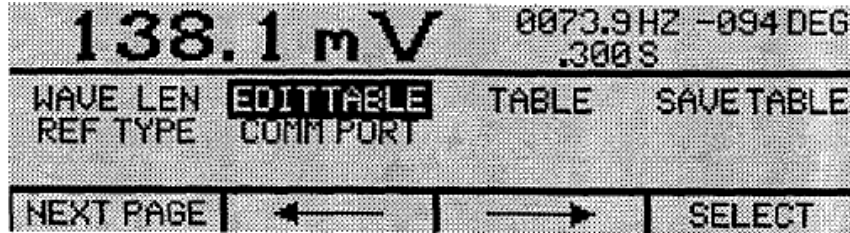

EDIT TABLE [SELECT] advances to the first wavelength table editing screen.

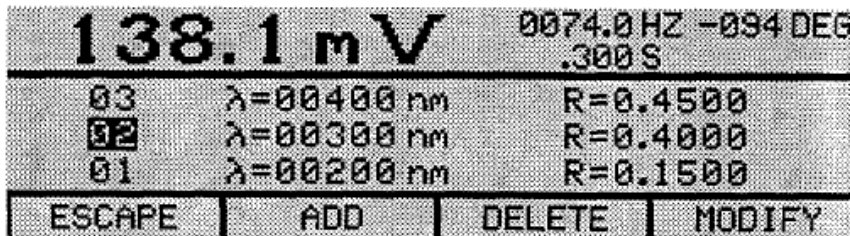

[ESCAPE] returns to menu #3, no change to wavelength table.

[ADD] inserts a wavelength point equivalent to the highlighted point and just above it, adjusts numeric index, positions the cursor in the wavelength data field for this new entry.

[DELETE] advances to the delete screen.

[MODIFY] advances to the modify screen, positions the cursor in the wavelength data field ready for modification.

Note that for **[ADD]**, **[DELETE]**, and **[MODIFY]** the up/down arrows on the keypad are used to scroll through the wavelength entries.

[ADD] SEQUENCE

138.1 mV		0074.0 HZ -094 DEG
		.300 S
04	λ=00400 nm	R=0.4500
03	λ=00300 nm	R=0.4000
02	λ=00300 nm	R=0.4000
ESCAPE	←	→
		ACCEPT

[ESCAPE] terminates the ADD procedure and returns to the first editing screen.

[<--] [-->] move cursor left/right one digit. The number keys and/or the keypad up/down arrow are used to modify the wavelength and response digits.

[ACCEPT] enters the new data point into the table, returns to the first table entry screen.

138.1 mV		0074.0 HZ -094 DEG
		.300 S
04	λ=00400 nm	R=0.4500
03	λ=00342 nm	R=0.4157
02	λ=00300 nm	R=0.4000
ESCAPE	ADD	DELETE
		MODIFY

Completed ADD.

[DELETE] SEQUENCE

138.1 mV		0073.8HZ -094 DEG
		.300 S
02	λ=00300 nm	R=0.4000
01	λ=00200 nm	R=0.1500
00	λ=00000 nm	R=1.0000
ESCAPE	DEL POINT	DELETE ALL

[ESCAPE] returns to first table edit screen, no deletion.
 [DEL POINT] deletes the selected point from the table.
 [DELETE ALL] deletes the entire table.

138.1 mV		0073.8HZ -094 DEG
		.300 S
02	λ=00400 nm	R=0.4500
01	λ=00300 nm	R=0.4000
00	λ=00000 nm	R=1.0000
ESCAPE	ADD	DELETE
		MODIFY

Completed DELETE.

[MODIFY] SEQUENCE

138.1 mV		0073.8 HZ -094 DEG
		.300 S
02	λ=00300 nm	R=0.4000
01	λ=00200 nm	R=0.1500
00	λ=00000 nm	R=1.0000
ESCAPE	←	→ ACCEPT

[ESCAPE] terminates the MODIFY procedure and returns to the first editing screen.
 [←] [→] move cursor left/right one digit. The number keys and/or the keypad up/down arrows are used to modify the wavelength and response digits.
 [ACCEPT] enters the new data point into the table, returns to the first table entry screen.

138.1 mV		0074.0 HZ -094 DEG
		.300 S
02	λ=00300 nm	R=0.4000
01	λ=00220 nm	R=0.0100
00	λ=00000 nm	R=1.0000
ESCAPE	←	→ ACCEPT

Completed MODIFY.

TABLE

This item is used to select either the stored (non-volatile) user table or the table that was read in from the (optional) calibration module at power up as the active wavelength table.

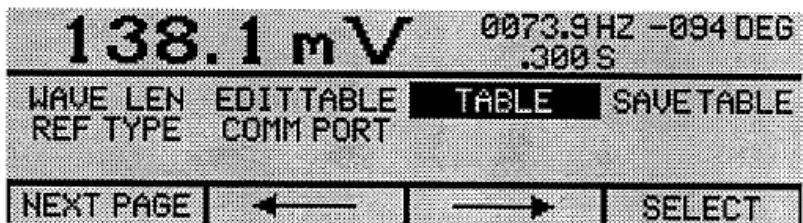
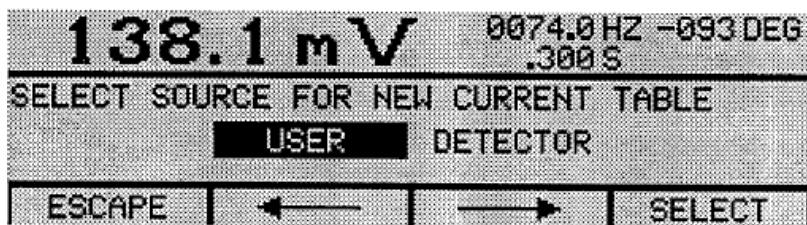

TABLE [SELECT] advances to the wavelength table selection screen.



[ESCAPE] returns to menu #3, no change to table selection.

[<---] [--->] move highlight bar left/right.

table [SELECT] chooses which stored table will be made active, returns to menu #3.

SAVE TABLE

This selection permits saving the current active table, whatever its source, as the non-volatile user table.

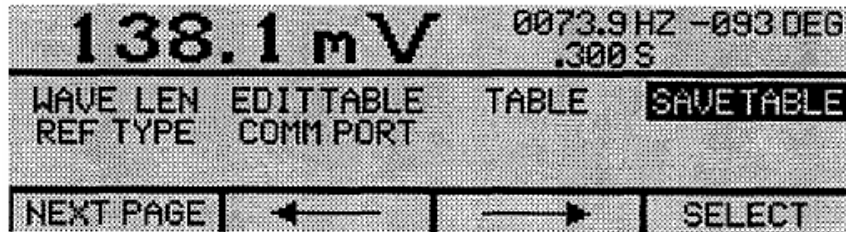

SAVETABLE [SELECT] advances to the wavelength table save screen.

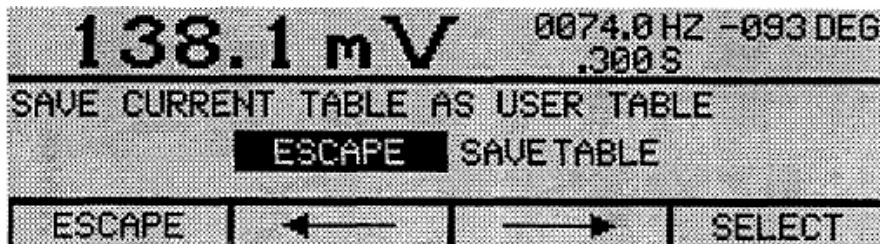

[ESCAPE] returns to menu #3, no change to saved table.

[<---] [--->] move highlight bar left/right.

ESCAPE [SELECT] returns to menu #3, no change to saved table.

SAVETABLE [SELECT] saves active table to user table, returns to menu #3.

REF TYPE

The reference channel may be processed as either AC or DC. This menu item permits that choice:

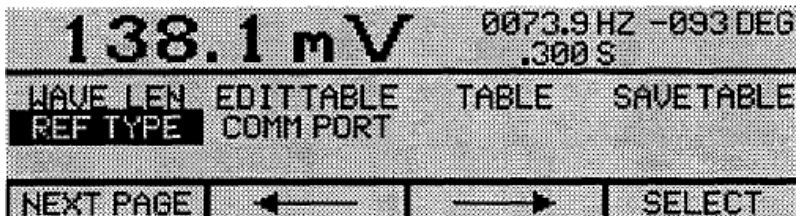

REFTYPE [SELECT] advances to the reference type screen.

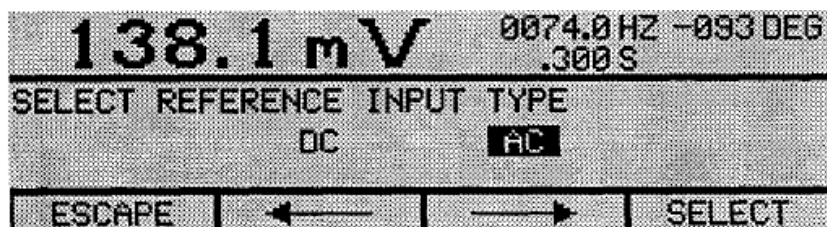

[ESCAPE] returns to menu #3, no change to reference type.

[<--] [-->] move highlight bar left/right.

ref type [SELECT] chooses type of reference signal, returns to menu #3.

COMM PORT

This selection is used to set up the communication port.

For the RS232 port the choices are:

BAUD RATE	300 to 9600
PARITY	odd, even or none
# of DATA BITS	7 or 8
#of STOP BITS	1 or 2

The RS232 is set up as a DCE device, transmitting on pin 3 and receiving on pin 2. No other communication lines are required.

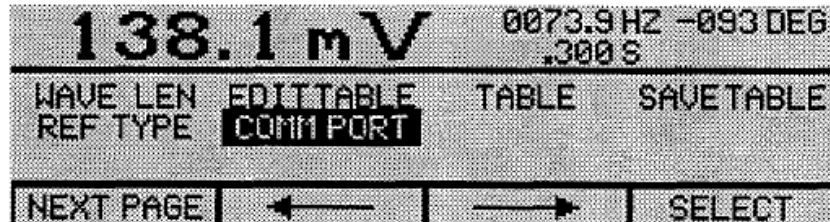

COMMPORT [SELECT] advances to the communications set up screen.

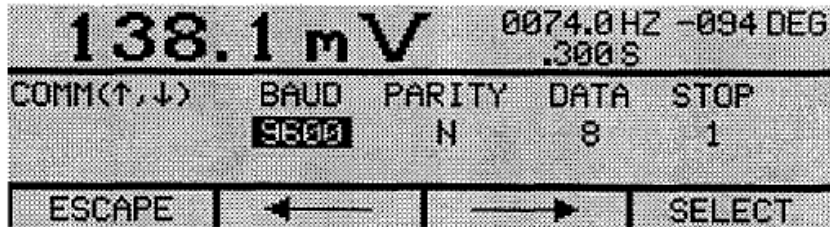

[ESCAPE] returns to menu #3, no change to comm port.

[<--] [-->] move highlight bar left/right. Keypad up/down arrows used to cycle through choices for each parameter.

Parameters [SELECT] chooses communication parameters, returns to menu #3.

VII. STAND-ALONE OPERATION OF MERLIN™ DETECTOR

PRELIMINARY

Set up the system along the lines suggested by

Figure 6. You may not have all the components shown there but your system should have a light source, a beam splitter and a reference detector, a sample space or compartment, a chopper, a signal detector and the Merlin™ Radiometer. The reference and signal detectors should be in heads with the appropriate preamplifiers so that their outputs are voltage signals. The components should be interconnected with appropriate cables; in particular, the reference detector's voltage signal should be connected to the reference input on the detector interface board.

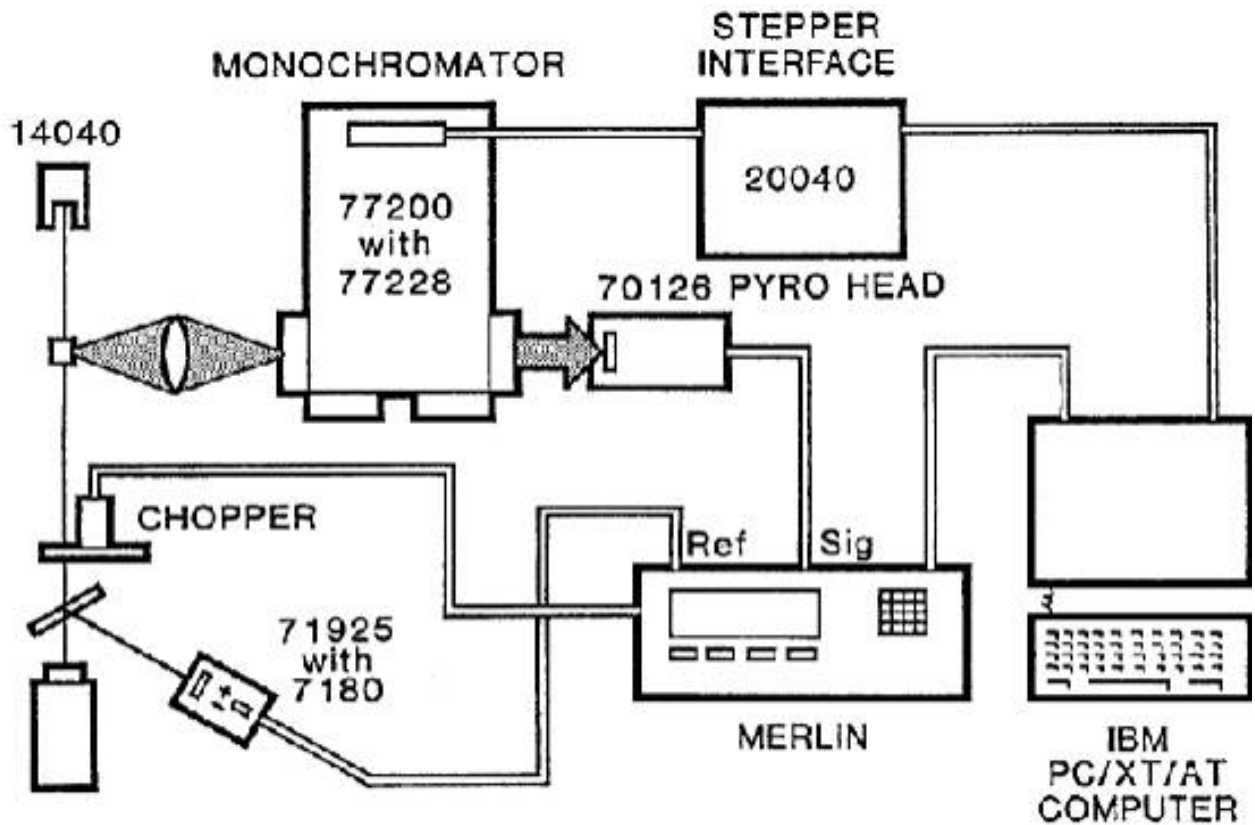

Figure 6: 79429 Diode Laser System

VII.1 SINGLE SIGNAL VS. RATIO

If a single signal system is to be used, and if only a single fluorescence wavelength is to be monitored, the 7180 reference detector and head are not needed, nor are the monochromator stepping drive components.

1. Turn on the power to all system components except the laser.
2. Crank the monochromator to the fluorescence wavelength which is to be observed
3. **Note** the voltage reading on the Merlin™. This is a measure of the system's dark signal
4. Turn on the laser
5. Again, observe the voltage reading on Merlin™. This is a measure of the total fluorescence and background signal
6. Subtract the reading in step 3 from the step 5 reading. This is the net signal due to fluorescence

Measuring near infrared fluorescence using the 79426 Diode Laser System as source, and ratioing the fluorescence signal to the excitation intensity.

Ratio Operation

1. Be sure the reference detector is in place in the beam and connected to the reference input of the Detector Interface Board.
2. Proceed with steps 1 through 4 above.
3. Set the reference channel to d-c, using **Ref Type**.
4. Increase the reference channel gain; i.e. the programmable amplifier gain. This is done using the **Ref Gain** menu item. Continue until the notation "2BIG" appears on the screen. Then reduce the gain by one or more steps, depending on how much the reference signal is expected to vary.
5. Observe the voltage reading on Merlin™. This is the total fluorescence and background signal.
6. Block the beam between the beam splitter and the chopper. Again note the Merlin™ reading. This is the background reading. Subtract it from the total reading to get the net signal due to fluorescence.

VII.2 SINGLE PHASE VS. TWO PHASE PROCESSING

In general you should use Two Phase or Vector processing since this is inherently less susceptible to any noise due to chopper variations. However, in some instances where the signal is very low, there may be noisy offset present on either the sine or cosine channel. This can lead to erratic data figures appearing on the display as the magnitude signal goes randomly from positive to negative values. Using single phase processing will eliminate the problem.

VII.3 CALIBRATED DETECTOR OPERATION

The detector heads supplied by Newport for use with Merlin™ are all calibrated at one wavelength and some may optionally be calibrated over a wavelength range. Each detector head will be calibrated in a radiation beam of known irradiance, and the calibration factor will be supplied with the detector. When a spectral calibration is supplied, the calibration factor at each wavelength will be provided in a PROM in the Calibration Module. These will be read into Merlin™ and may be applied to each wavelength so that the number appearing on the screen will be the correct value with the correct units.

Generally, there are three factors that must be used to obtain radiometric readout from Merlin™: spectral calibration data, calibration scale number, and wavelength.

Spectral calibration data (noted as K_λ) is provided in volts/watt. For wavelength specific measurements in watts, these calibration constants must be entered into Merlin™. When a Calibration Module is plugged in, the data is automatically entered into the DETECTOR table as power is turned on. Data in the "detector" table is loaded to the "active" table by selecting TABLE from menu screen #3, and then selecting DETECTOR. Without a calibration module data may be manually entered directly into the "active" table using the EDITTABLE menu selection on menu screen #3. In all cases calibration information may be saved for future use by selecting SAVETABLE on that same menu screen. This saves that data to the "user" memory area.

Calibration scale numbers (noted simply as K) are generally unitless values related to some physical feature of the detector itself or its electronics. This value is entered by selecting UNITS on menu screen #2, then choosing the correct unit type from the list (usually W, for watts), and then typing the appropriate calibration scale number followed by ACCEPT and DONE.

Since most Merlin™ detectors have some wavelength dependent response the calibrated readout will not be accurate unless you explicitly declare the wavelength you are measuring. This can be done on the front panel by selecting WAVELENGTH from menu screen #3 and then using the keypad to enter the correct value. The wavelength must be within the bounds of your "active" table. The wavelength will be shown in the upper right corner of the display.

For your information the calibration calculation Merlin™ does follows here:

$$\text{display output} = (K / K_\lambda) \times \text{input signal}$$

Where K_λ comes from the wavelength table and is specified by the wavelength you enter. Merlin™ will interpolate (linearly) between values in the wavelength table. Also, selecting a wavelength of 0000 nm sets K_λ to 1.0000.

For explicit directions on how to use Merlin™ with your calibrated detector, to obtain readings in radiometric units please see the detector manual.

VII.4 INTERNAL/EXTERNAL CHOPPER CONTROL

In most cases a Merlin™ system will be operated with the chopper under Merlin's control. In this case the **Chopper** menu entry would be set to **Internal** and the frequency can be set using the **Frequency** menu entry.

In some instances it may be desirable to have the chopper controlled by some external signal. In this case the **Chopper** menu entry should be **External** and an external sync signal can be used for chopper control. Merlin™ will then sync to the external signal.

VII.5 TWO CONFIGURATION CAPABILITY

The Merlin™ can support two different instrument configurations. These configurations, referred to as "SETUP 1" and "SETUP 2", coexist within the Merlin™ memory and may be selected either through the Merlin™ panel or remotely by computer.

When combined with the Model 70102 - an upgrade package for the Merlin™ that provides a complete second analog signal processing section for both main and reference detectors - this two configuration capability permits easy switching between two detector/instrument setups without any detector movement or disconnection.

In the conventional single channel Merlin™, this two configuration capability permits access to two independent setups. In this case, "SETUP 1" and "SETUP 2" both apply to the same analog processing channel, but may define two unique Merlin™ configurations.

Below are some notes on the two configuration operation.

- "SETUP 1" and "SETUP 2" are manually selected via the **SETUP** selection on menu screen #3.
- The "USER" table is shared by "SETUP 1" and "SETUP 2". The "Detector" table and active table are independent.
- "SETUP 1" is selected automatically at power up.
- Computerized selection of "SETUP 1" requires transmission of "PD 3FF2 0" from the computer, "SETUP 2" requires "PD 3FF2 1". Note that in the remote eventuality of the leftmost menu button being pressed at the same instant that the computer is switching between configurations, a "Factory Restore" will be executed and the current customized setups will be lost and will have to be reentered.

NOTE: The basis for this two configuration operation is built into all Merlins identified with V3 or a higher version on the serial number label. Merlins identified by V1 or V2 may be retrofitted to incorporate this capability. Consult Newport for details.

VII.6 MODEL 70102, SECOND DETECTOR CHANNEL

The Model 701 02 is an upgrade package for the Merlin™ that provides a complete second analog signal processing section for both main and reference detectors. The 701 02, consisting of a second Detector Interface Board and a special Analog Signal Processing Board, permits switching between two detector setups without any physical changes. Selection may be accomplished either through the Merlin™ panel or remotely by computer.

The 701 02 Detector Interface Board is identical in function and outside world connections to the standard Detector Interface Board. Each main detector channel may use a Calibration Module.

The 70102 Analog Signal Processor is similar to the standard in function. However, the standard, "SETUP I", Analog Signal Processor has the conventional "SYNC IN", "ANALOG OUT" and "SYNC OUT" BNCs on the rear panel, while the 701 02, "SETUP 2, Analog Signal Processor only has a "SYINC OUT" BNC. The "SYNC IN" and "ANALOG OUT" signals reflect the selected configuration, while the "SYNC OUT" BNC is dedicated to each setup.

The order of these analog processing modules, when Merlin™ is viewed from the rear, starting from the right, is standard Detector Interface (slot 6 on the Mother Board), the standard Analog Signal Processor (slot 5), the 701 02 Detector Interface (slot 4) and the 70102 Analog Signal Processor (slot 3).

Below are some notes on the 70102 operation.

- "SETUP 1" is selected automatically at power up.
- "SETUP 1" refers to the standard signal processing channel while "SETUP 2" denotes the 701 02 channel.
- "SETUP 1" and "SETUP 2" are manually selected via the **SETUP** selection on menu screen #3.
- The "USER" table is shared by "SETUP 1" and "SETUP 2". The "DETECTOR" table and active table are independent.
- Computerized selection of "SETUP 1" requires transmission of "PD 3FF2 0" from the computer, "SETUP 2" requires "PD 3FF2 1 ". Note that in the remote eventuality of the leftmost menu button being pressed at the same instant that the computer is switching between configurations, a "Factory Restore" will be executed and the current customized setups will be lost and will have to be reentered.

NOTE: The basis for this two detector operation is built into all Merlins identified with V3 or a higher version on the serial number label. Merlins identified by V1 or V2 may be retrofitted to incorporate this capability. Consult Newport for details.

VII.7 INSTALLATION INSTRUCTIONS FOR MERLIN™ ADDITIONAL DETECTOR CHANNEL MODEL 70102

The following procedure should be followed for installing 70102 printed circuit boards:

1. Turn OFF the Merlin™ and unplug the AC line cord.
2. Remove the cover
 - a. Remove seven (7) screws holding the cover (two on each side, three at the top of the rear panel).
 - b. Tilt cover (about 45°) and slide forward until it clears the chassis.
 - c. Rotate the cover clockwise and lay it down on its right side.
3. Remove the dummy rear panels for mother boards slots 3 and 4.
4. Insert the 70102 Detector Interface Board into slot 4 on the motherboard and the 70102 Analog Signal Processor into slot 3.
 - a. Place board over the appropriate board connector.
 - b. Insert by pressing down gently, but firmly, on the top edge of the printed circuit board. Care should be taken to make sure that the tab at the bottom of the module panel stays aligned with the slot at the bottom of the rack.
 - c. Screw panel to rack.
5. Re-assemble the cover, reversing the removal procedure. Care should be taken not to pinch the front panel cables between the bottom of the cover and the chassis. Gently pulling the cables from inside the chassis as the cover is brought to the chassis should avoid any problems.
6. Access to the 70102 Detector Channel is achieved through the **SETUP** selection on the third menu screen or via computer. The 701 02 configuration is identified as "SETUP 2" Reference your Merlin™ manual for more information.

VIII.COMPUTER CONTROLLED OPERATION OF MERLIN™

In addition to Merlin's utility as a stand alone instrument, either of the computer interfaces, RS-232 or IEEE-488, permit integration into a computerized measuring system. The Merlin™ memory monitor allows a host computer to read from and write to Merlin's memory. Measurement data can be read from Merlin's memory while set up data can be read and modified through the monitor. The monitor is accessible via either the RS-232 or IEEE-488 Merlin™ interfaces.

The Runes™ software package allows signal data to be read easily from Merlin™ by a host computer. The data may then be manipulated within Runes™ as you choose. Runes™ has been developed specifically to facilitate the taking of complete spectra in conjunction with an Oriol computer controlled monochromator. Runes™ utilizes the Merlin™ RS-232 serial interface.

Computer controlled operation of Merlin™ is usually done when a monochromator is used to make spectral measurement. Fig. 7 shows a typical arrangement. A computer plug-in board (for IBM PC™ compatibles) connects to the 20040 Stepper Interface. The 20040 then connects to any ORIEL Monochromator fitted with a Stepper Drive. The software allows you to input grating data and initial wavelength, and then execute spectral scans. You set scan limits, wavelength increment and **read and wait times** for data acquisition.

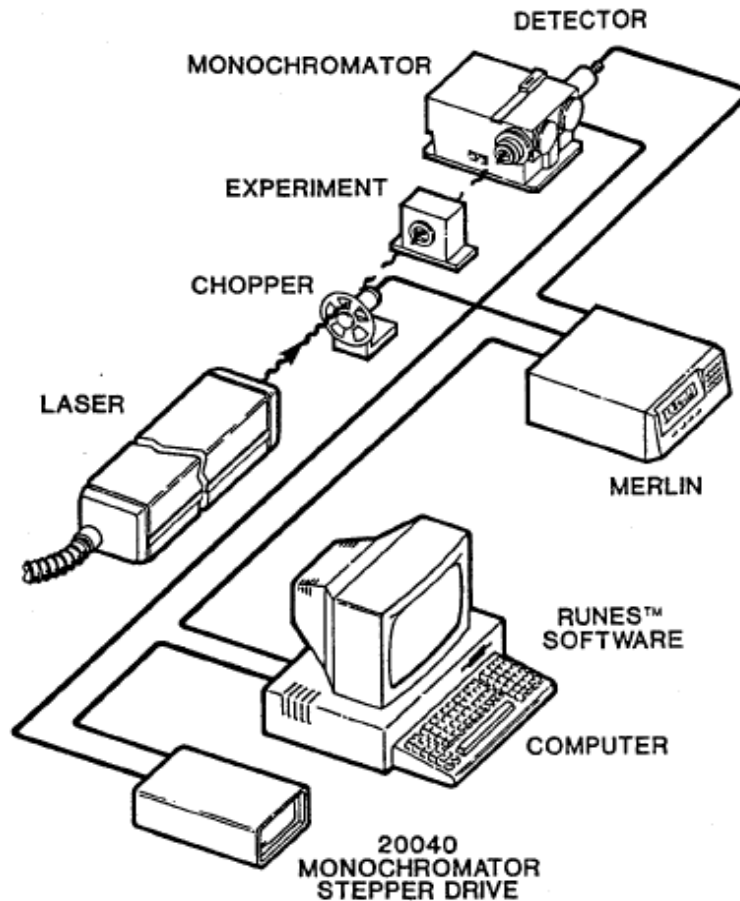

Figure 7: Typical arrangement for spectral measurements with Merlin

VIII.1 THE RUNES™ SOFTWARE PACKAGE

Software Modules

With the Runes™ software you can easily take signal levels from Merlin™ and use file manipulation as you choose. For convenience, the software includes **Spectroradiometry** and **Absorption** modules. Absorption allows automatic ratioing of sequential scans for immediate computation of absorption. Spectroradiometry allows entry of data for calibrated lamps such as ORIEL'S 63361. When you run a scan on a calibrated lamp and then an unknown, the data for the unknown is presented in the corrected radiometric units.

Merlin's Double Beam Capability

As Merlin™ uses chopped light and subtracts a zero every chop cycle, it already compensates for zero drift or zero variance through a spectral scan. This advantage is enough in many cases to negate the need for double beam operation, but if your application demands double beam measurements, you can use the **reference** and **ratio** features of Merlin™. You can take the ratioed value directly to the computer.

What Does Runes™ Consist Of?

Runes™ includes a **simple plug-in interface card** for an IBM PC™ compatible computer, a **cable** to the 20040 Stepper Interface that provides the power to drive the monochromator, and the **Runes™ software** for IBM™ compatible computers. Runes™ is described in more detail in a separate manual.

What you will need

You will need an RS 232 communications port and standard PC serial communications cable from your computer to the DB-25 RS 232 socket on the Merlin™. Since Merlin™ and Runes™ both use hardware handshaking, the serial cable must support these signals. The software requires up to 500 k of free memory. You will need another comm port if you use a plotter and an LPT port if you use a printer. A math co-processor is not required, but will speed screen plotting and file manipulation.

After the stepper motor makes the selected wavelength increment, and the selected **wait time**, the computer takes in data from Merlin™ over the RS 232 link. With zero read time, this will be a single reading. If you want the computer to perform signal averaging, select a non zero read time.

The data value from Merlin™ is displayed on the computer and stored to file for archiving or plotting. The software allows arithmetic operations with files; you can multiply, divide, add and subtract files. You can then plot the data to the screen. You can select the range for the plotting axes, linear or logarithmic display of data and compensate for wavelength offset if needed. Fig. 8 shows an actual plot produced by a **HP ColorPro™** Plotter. (You can also produce hardcopy plots on many popular printers including HP™ laser printers.)

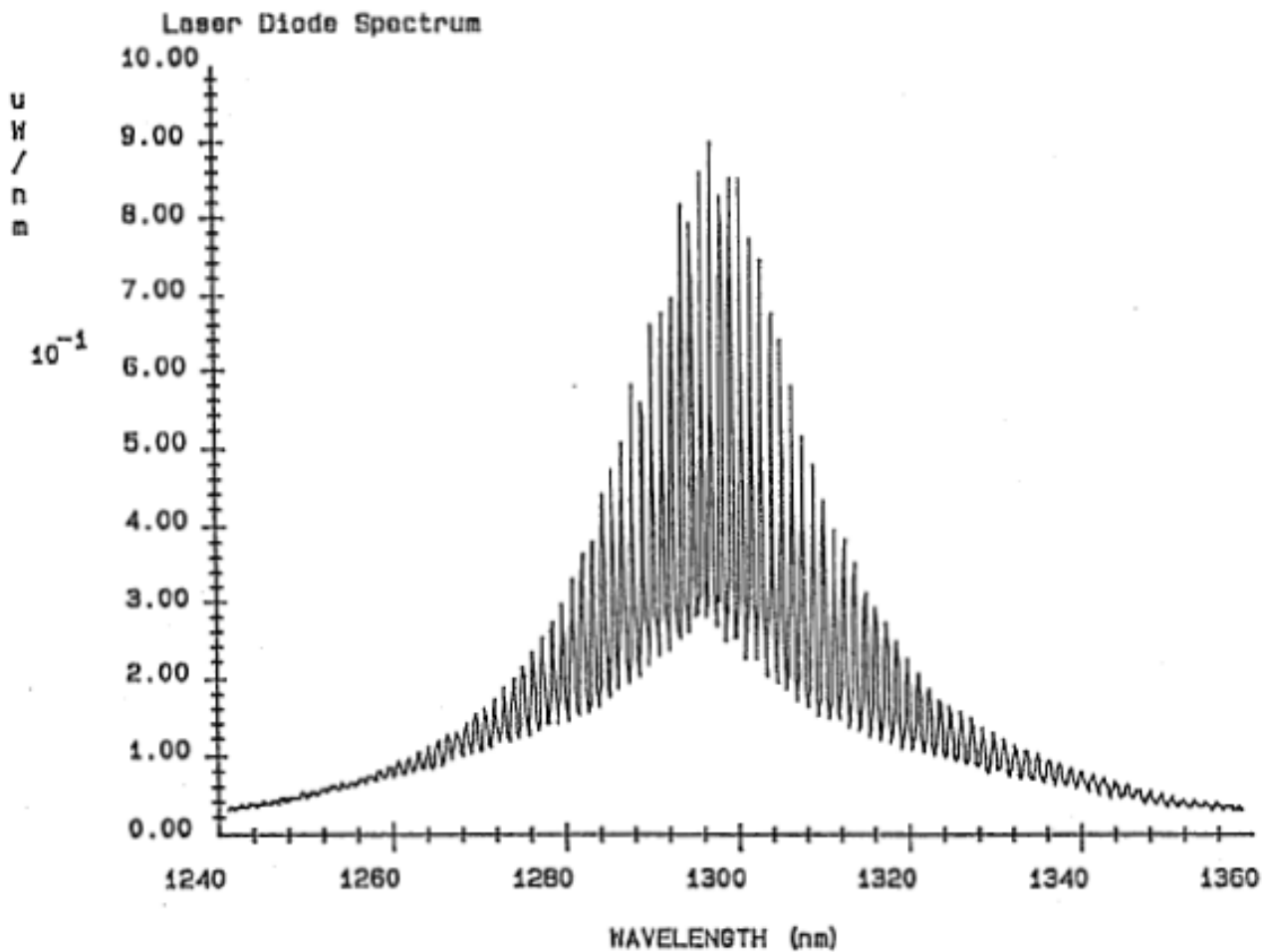

Figure 8: Laser Diode Spectrum

Plot of spectrum of an infrared diode laser monitored by a Merlin™ System with the monochromator operated by Runes™. We used a 77225 Double 1/4M Monochromator fitted with a 77245 Dual Ratio Stepper Drive to achieve the high resolution shown. The data was plotted on a HP™ Plotter.

VIII.2 TALKING TO MERLIN™

The Merlin™ memory can be accessed through the Merlin™ Memory Monitor. The command format is the same for either the RS-232 or IEEE-488 interface.

Communication Format

There are two basic commands for accessing the Merlin™ memory: Put Data (**PD**) and Take Data (**TD**). There is a special procedure for transferring the current reading displayed to the computer, which is covered in Section 8.3.

See the Appendix for a listing of Merlin™ memory locations and the significance of the values stored in these locations.

The Put Data (PD) command allows modification of Merlin™ memory locations. An ASCII string of the following form should be sent:

```
"PD" _ <lot> , _ <vat> <CR>
```

where anything in quotes is sent literally

_ indicates a space. The space after PD is for clarity and may be eliminated.

<loc> is the starting memory location; a 4 digit hex string (leading zeros may be ignored)

<val> is the value to be written into <loc>; a 4 digit hex string (leading zeros may be ignored).

<CR> is an ASCII carriage return

for example PD _ 1808 _ 1 <CR> turns on the autorange function by writing the value "1" into memory location "1808".

The Take Data (TD) command allows reading of Merlin™ memory locations. An ASCII string of the following form should be sent:

```
"TD" _ <lot> _ <words> <CR>
```

where anything in quotes is sent literally

_ indicates a space. The space after TD is for clarity and may be eliminated.

<loc> is the starting memory location; a 4 digit hex string (leading zeroes may be ignored).

<words> is the number of words desired; a 4 digit hex string (leading zeros may be ignored).
Omitting <words> will result in one word being sent back.

<CR> is an ASCII carriage return.

Merlin™ responds to the "**TD**" command by returning the requested data in the following format:

```
<CR> ">" <CR> <XXXXX> ["_ " <XXXXX>] <CR> ">"
```

where anything in quotes is sent literally

_ indicates a space.

<CR> is an ASCII carriage return

<XXXX> is a single 16 bit work; 4 digit hex string

anything in brackets can be repeated 0 or more times (depending on value contained in <words>).

for example TD _ 1830 _ 2 <CR> requests the values of two successive memory locations, 1830 and 1831 (the set frequency value).

The Merlin™ might respond with:

```
> <CR>
```

```
> 0000_0100 <CR>
```

```
>
```

which decodes as a frequency of 10.0 Hz. (see the Appendix for explanation).

VIII.3 ACCESSING THE DISPLAYED READING

The displayed reading is the value in the readout portion of the Merlin™ display. Because this value is not only the most significant but also dynamic, a special procedure has been created to access this displayed reading which may have changed by the time the transfer has been completed. For those applications where the numeric value of the present reading is the parameter of interest, the following procedure is recommended.

```
PRO
TD 2_2   where _ indicates a space
<CR> is an ASCII carriage return
```

PRO invokes a Merlin™ sub-routine, which transfers the reading values to memory locations 1, 2, and 3. The displayed reading value is now isolated from any subsequent changes since these registers will not be updated until another computer request for data is issued. The TD statement then reads the words at locations 2 and 3. The interpretation of the returned values is shown below.

<u>loc</u>	<u>word</u>	<u>interpretation</u>
2	1	xyzz (4 digits)
		X= mantissa sign: 0=positive 1=negative
		Y=base 10 exponent sign: 0=positive 1=negative
		zz = base 10 exponent as BCD string:
3	3	nnnn mantissa as BCD string with an implied decimal point after the first digit.

For example, if Merlin™ responds with the string
 <CR> ">" <CR> "01 ab cdef" <CR> ">"
 the parsed value is +c.def 10^{-ab} volts.

This information will satisfy most needs. There is, additionally, a third word that is transferred when PRO executes and it provides information about other display related features such as units, readout type, log type, and factor as well as containing the most significant digit of the log value (values > xx.xx dB are permitted) and the numeric saturation flag. To access this word along with the two previously defined, the procedure is:

```
PRO
TD_1_3
```

This TD statement reads the words at locations 1, 2, and 3. The interpretation of the three returned words is as follows:

<u>loc</u>	<u>word</u>	<u>interpretation</u>
1	1	f ₀ e ₂ e ₂ e ₀ d ₁ d ₀ c ₂ c ₁ c ₀ b ₃ b ₂ b ₁ b ₀ a ₂ a ₁ a ₀ (16 bits as 4 hexadecimal words)
		a ₂ a ₁ a ₀ – most significant digit of log value. 0 0 0 = 0

0 0 1 = 1
 0 1 0 = 2
 0 1 1 = 3
 1 0 0 = 4
 1 0 1 = 5
 1 1 0 = 6
 1 1 1 = 7

$b_3b_2b_1b_0$ = units
 0 0 0 0 = volts
 0 0 0 1 = watts
 0 0 1 0 = amps
 0 0 1 1 = lumens
 0 1 0 0 = watts/cm²
 0 1 0 1 = watts/cm²/nm

$c_2c_1c_0$ = readout type:
 0 0 0 = scientific
 0 0 1 = engineering
 0 1 0 = log

d1d0 = log type:
 0 0 = dB (10)
 0 1 = dB (20)
 1 0 = dBm (10)
 1 1 = dBm (20)

$e_2e_1e_0$ = factor
 0 0 0 = K(units)
 0 0 1 = 1/REF
 0 1 0 = 1/SIGFS
 f_0 = numeric saturation
 0 = not saturated
 1 = saturated

2	2	xyzz as above
3	3	nnnn as above

As an example, Merlin™ might respond to the "PR O/TD 1 3" commands with the string
 <CR> "0088 01 ab cdef" <CR>
 which parses to the same numeric as above, +c.def 10^{-ab}, but the additional information in the first word indicates that the factor type is K(units), the units are watts, and the display format is set for engineering notation. This information usually does not change over the duration of a test and, therefore, probably does not need to be monitored.

VIII.4 PROGRAMMABLE FUNCTIONS

The following list defines the syntax for setting the respective Merlin™ menu items.

The information is presented in the Merlin™ programming format of "**PD arg1 arg2**". For example, "**PD 1814 0**" will write the value 0 into memory location 1814, turning off the filter.

Conversely, to read these variables, the format is "**TD arg3 arg4**". For example, "**TD 1814 1**" requests the value of one memory location starting at location 1814. Merlin™ will respond with a value of either 0 (no filter), 1 (1 pole) or 2 (2 pole).

The examples are given with the memory locations for the configuration "SETUP 1". To access corresponding memory locations for configuration "SETUP 2", use an offset value 0080 hexadecimal. For example, to set the time constant for the configuration "SETUP 2 you will use memory location: 180C + 0080 = 1 88C.

References to special procedures (PRx) and wavelength table data are satisfied in the following sections:

FILTER:

# OF STAGES	"PD 1814 0"	and	"PD 1812 0 0"	=	NONE
	"PD 1814 1"			=	1_POLE
	"PD 1814 2"			=	2_POLE

TIME CONSTANT	"PD 180C 0"	and	"PD 1812 0 7530"	=	.003S
	"PD 180C 1"	and	"PD 1812 1 86A0"	=	.010S
	"PD 180C 2"	and	"PD 1812 4 93E0"	=	.030S
	"PD 180C 3"	and	"PD 1812 F 4240"	=	.100S
	"PD 180C 4"	and	"PD 1812 2D C6C0"	=	.300S
	"PD 180C 5"	and	"PD 1812 98 9680"	=	1.00S
	"PD 180C 6"	and	"PD 1812 1C9 C380"	=	3.00S
	"PD 180C 7"	and	"PD 1812 5F5 2578"	=	10.0S
	"PD 180C 8"	and	"PD 1812 11E1 A300"	=	30.0S
	"PD 180C 9"	and	"PD 1812 3B9A CA00"	=	100S

SYNC (see also **CHOPPER**)

"PD 1800 0"	=	INTERNAL & chopper off
"PD 1800 1"	=	INTERNAL & chopper on
"PD 1800 2"	=	EXTERNAL & chopper off
"PD 1800 3"	=	EXTERNAL & chopper on

FREQUENCY **abcd.e HZ** see **PR2**

PHASE	"PD 1822 0"	=	1_PHASE
	"PD 1822 1"	=	2_PHASE

CHOPPER (see also **SYNC**)

NOTE: "**PD 0039 1**" at any time will run the calibration cycle (ON+CAL)

SET SIG FS	"PD 0034 1" =	saves the present main channel signal reading as the signal full scale (SET_SIG_FS)
-------------------	---------------	---

SET REF FS “PS 0035 1” = saves the present reference channel reading as the reference full scale (SET_REF_FS)

LOG OFFSET “PD 0033 1” = sets the offset to zero. (CLR_ZERO)
 “PD 0033 2” = saves the present main signal reading as at the logarithmic basis. (SET_ZERO)

SIG OFFSET “PD 0030 1” = sets the signal offset to zero. (CLEAR_ZERO)
 “PD 0030 2” = saves the present measurement main channel signal reading as the signal offset. (SET_ZERO)

REF OFFSET “PD 0033 1” = sets the reference offset to zero. (CLEAR_ZERO)
 “PD 0030 2” = saves the present reference channel reading as the reference offset. (SET_ZERO)

ZERO PHASE “PD 0032 1” = sets the phase angle reference value to zero.
 “PD 0032 2” = saves the present measured phase angle as the reference phase angle. (ZERO_PHASE)

AUTORANGE “PD 1809 0” = OFF
 “PD 1808 1” = ON

UNITS:

SCALE NUMBER **w.xyz E ±ab** see PR4

WAVE LEN **abcde nm** see PR3

EDIT TYPE see **WAVELENGTH TABLE DATA**

REF TYPE “PD 1823 0” = DC
 “PD 1823 1” = AC

SETUP “PD 3FF2 0” = SETUP_1
 “PD 3FF2 1” = SETUP_2

VIII.5 SPECIAL PROCEDURES

PRO: READING THE DISPLAYED VALUE

Purpose: Transfer the value being displayed in the readout portion of the Merlin™ screen to a buffer area where it will remain until read.

Format: PRO

Comments: This command results in three words being transferred to the buffer memory locations 1,2 and 3 where they will remain until either read or written over as the result of some computer action.

Examples: PRO
TD 2 2
or
PRO
TD 1 3

PRO causes the three word internal transfer in both cases. **TD 2 2** reads the values from locations 2 and 3 which contain the numeric information. **TD 1 3** also reads out the word from location 1 which contains additional information about the displayed value. See section 8.3 of the Merlin™ manual for interpretation of these data words.

PR1 : DISABLE FRONT PANEL BUTTONS

V5 or later Merlin™ required

Purpose: Set, clear, and query the state of the Front Panel Button Disable switch.

Format: PD1 *arg1*
PR1

[TD1] (use with *arg1* = 2)

arg1 specifies action of PR1 to set (*arg1* = 1), clear (*arg1* = 0), or query (*arg1* = 2).

Comments: Setting the Disable switch also causes Merlin™ to display its "main" screen. The menu bar above the function buttons is also blanked indicating that no buttons are active.

Resetting the Disable switch restores the function button menu bar and reactivates the related buttons.

If query is selected, sending TD1 to Merlin™ will cause the state of the switch to be returned, where 0000 indicates "cleared" and 0001 indicates "set".

Examples: PD1 1
PR1

Sets the Front Panel Button Disable switch.

PD1 0
PR1

Clears the Front Panel Button Disable switch.

PD1 2
PR1
TD1

Causes Merlin™ to return the current state of the Front Panel Disable Switch.

PR2: SET FREQUENCY

V5 or later Merlin™ required

Purpose: Provides means for setting MERLIN'S analyzing frequency between 8.0 and 1 100.0 Hz.

Format: **PD1 *arg1 arg2***
PR2

arg1 specifies the integer part of the desired frequency. Values may range from 8 to 1100 Hz.

arg2 specifies the fractional part of the desired frequency in 0.1 Hz increments. Values of 0 to 9 are allowed. If *arg1* is 1100, *arg2* must be 0.

Comments: Trying to set a frequency outside the range of 8.0 to 11 00.0 Hz will cause Merlin™ to issue a "beep", indicating that the request was denied.

If the (set) FREQUENCY screen was selected by Front Panel Buttons when this command is issued by the host computer, the "current" and "desired" settings on the screen will not reflect the host's update. Exiting this screen may also negate the host command. It is advisable that a PR1 command be issued prior and subsequent to using PR2.

Examples: **PD1 8 0**
PR2

Sets the analyzing frequency to 8.0 Hz.

PD1 1023 9
PR2

Sets the analyzing frequency to 1023.9 Hz.

Read: **TD 1830 2** causes Merlin™ to respond with the values in memory locations 1830 and 1831. The data returned will be of the form **000a bcde** which is the decimal representation of the frequency *abcd.e* Hz. As examples, a response of **0001 0052** represents 1005.2 kHz and **0000 1234** indicates a frequency of 123.4 Hz.

PR3: SET WAVELENGTH

V5 or later Merlin™ required

Purpose: Provides means for changing MERLIN'S wavelength setting.

Format: **PD1 arg1 arg2**

PR3

arg1 specifies the 10000's digit of the desired wavelength. Values may be 0, 1, or 2, corresponding to 00000 nm, 10000 nm, and 20000 nm, respectively

arg2 specifies the remaining digits of the desired wavelength. Values of 0 nm to 9999 nm are allowed.

Comments: Wavelength specifications must range between the minimum and maximum values defined in the active wavelength table. Merlin™ will sound a "beep" if the setting is outside this range, indicating that the request was denied.

Specifying a wavelength of 0 nm will disable the table and result in a table value of 1.0000.

If the (set) WAVELENGTH screen was selected by Front Panel Buttons when this command is issued by the host computer, the "current" and "desired" settings on the screen will not reflect the host's update. Exiting this screen may also negate the host command. It is advisable that a PR1 command be issued prior and subsequent to using PR3.

Examples: **PD1 1 0002**

PR3

or

PD1 1 2

PR3

Sets the wavelength to 10,002 nm.

Read: **TD 183C 2** causes Merlin™ to respond with the values in memory locations 183C and 183D. These values are the hexadecimal representations of the selected wavelength and responsivity, respectively. The wavelength value is in nanometers and the responsivity is the normalized value with 4 decimal places. For example, a response of **01A4 1075** represents a wavelength of 420 nm (0x01A4 = 420) and a responsivity of 0.421 3 (0x1 075 = 421 3).

PR4: SET CAL SCALE NUMBER

V5 or later Merlin™ required

Purpose: Provides means for changing MERLIN'S calibration scale number

Format: **PD1 arg1 arg2**

PR4

arg1 specifies the 4 digit mantissa part of the calibration scale number. The decimal point is assumed to be at the right of the left-most digit. Values may range from range from 1000 (1.000) to 9999 (9.999).

arg2 specifies the exponent part of the calibration scale number. A negative sign is applied by adding 100 to the exponent. Values may range from 0 to 19 for positive exponents and from 100 to 119 (-0 to -19) for negative exponents.

Comments: Merlin™ does not check arg1 or arg2 for valid settings.

Setting the magnitude of a negative exponent greater than -12 (eg. -13, -14) May 6, 2005 produce errors in the MERLIN'S output, particularly with very small inputs.

If the (set) UNITS screen was selected by Front Panel Buttons when this command is issued by the host computer, the "current" and "desired" settings on the screen will not reflect the host's update. Exiting this screen may also negate the host command. It is advisable that a PR1 command be issued prior and subsequent to using PR4.

Examples: **PD1 1234 105**

PR4

Sets the cal scale number to 1.234E-05.

READ: **TD 1833 3** causes Merlin™ to respond with the values in memory locations 1833, 1834 and 1835 which represent respectively, the mantissa, exponent sign and exponent of the scale number. The mantissa and exponent are decimal values and the exponent sign is either 0000 for positive or F000 for negative. For example, a response of **1234 F000 0005** represents 1.234E-05.

VIII.6 WAVELENGTH TABLE DATA

Merlin™ contains three distinct wavelength/responsivity tables; each table consists of up to 9 wavelength/responsivity pairs. The wavelength range is 1 to 29,999 nm and the responsivity is a normalized value from 0.0001 to 1.9999. Wavelength entries are in ascending wavelength order.

The three tables are:

- Detector table: Loaded from the calibration prom, if present, at power on.
- User table: Copy of the Active Table, saved by user command.
- Active Table: The table which Merlin™ is presently using. May be a copy of either the User or Detector table, a table modified from one of these or a table created from scratch.

The Active and User tables are saved in non-volatile memory. The Detector table is updated every time power is applied to the Merlin™. If there is no calibration prom, the Detector table is cleared at power on.

Addresses for Wavelength Table Entries

	Detector Table	User Table	Active Table Setup 1	Active Table Setup 2
Number of pairs	@ 0x0A000	@ 0x1900	@ 0x1A00	@ 0x1B00
Wavelength	#1 @ 0x0A04 #2 @ 0x0A06 #99 @ 0x0AC8	#1 @ 0x1904 #2 @ 0x1906 #99 @ 0x19CB	#1 @ 0x1A04 #2 @ 0x1A06 #99 @ 0x1AC8	#1 @ 0x1B04 #2 @ 0x1B06 #99 @ 0x1BC8
Responsivity	#1 @ 0x0A05 #2 @ 0x0A07 #99 @ 0x0AC9	#1 @ 0x1905 #2 @ 0x1907 #99 @ 0x19C9	#1 @ 0x1A05 #2 @ 0x1A07 #99 @ 0x1AC9	#1 @ 0x1B05 #2 @ 0x1B07 #99 @ 0x1BC9

Values in the Wavelength Tables

Number of Wavelength/Responsivity Pairs:

Values from 0x01 to 0x63 equate to 1 to 99 pairs.

NOTE: the Ox prefix indicates a hexadecimal value, ∴ 0x63 = 63 hex.

Wavelength:

Values from 0x0001 to 0x752A equate to wavelengths of 1 to 29,999 nm.

Responsivity :

Values from 0x0001 to 0x4E1 F equate to normalized responsivity of 0.0001 to 1.9999.

Reading Data from a Table

The command format is 'TD address # where "TD" is the Merlin™ monitor command for take data, "address" is the starting memory address for the read and " # is the number of memory locations to be read.

For example, to read the second and third data pairs in the Active table, the command sent to Merlin™ would be "TD 1A06 4", and Merlin™ might respond as follows:

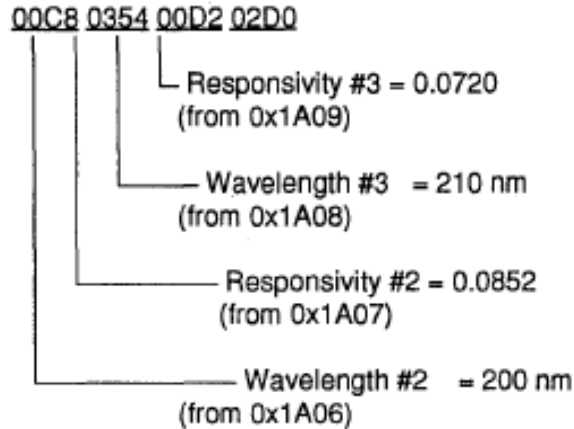

Writing Data to a Table

The command format is "PD address list" where "PD" is the Merlin™ monitor command for put data," address" is the starting memory address for the put and "list" is a sequence of values, separated by spaces, to be stored in the memory locations starting at "address".

For example, to write a 4 entry user table, the command sequence would be:

"PD 1900 4" which sets up the table for 4 entry pairs. Note that a value less than the actual number of data pairs will cause the table to be truncated; a value greater than the number of pairs will fill the space above the last entry with zeroes.

"PD 1904 λ_1 , R_1 , λ_2 , R_2 , λ_3 , R_3 , λ_4 , R_4 ,"

where A , and R_i , are the wavelength and responsivity values, respectively, to be stored with A at memory location $0x1\ 904_i$, R_1 , at $0x1\ 905$, λ_2 , at $0x1\ 906$, etc.

VIII.7 IEEE - 488 SAMPLE SESSION

Setting up Merlin™

In order to prepare the Merlin™ to run as part of an IEEE-488 system, you must select a device address (if the default address of 01 is not acceptable) and hook up to the IEEE controller.

To modify the device address, select COMMPORT from the third Merlin™ menu screen and use either the numeric keypad or the up/down arrow keys to change the desired device address. SELECT the address and then exit by pushing DONE. The Merlin™ will have to be powered off and back on and the system controller addresses updated.

A Sam& Session with National Instruments GPIB-PCIIIIA board and NI-488 3 Software for DOS

With the National Instruments board and software in place in the computer, connect the computer to Merlin™ with the cable provided and power both units on. From the AT-GPIB directory, load IBCONF. Do an Autoconfig (F3). Move the highlight to DEVI and select edit (F8). The configuration should be edited to:

Primary GPIB Address	1 or as selected on Merlin
Secondary GPIB address	NONE
Timeout setting	1 sec
Serial Poll Timeout	1 sec
Terminate Read on EOS	No
Set EOI with EOS on Writes	No
Type of compare on EOS	7-Bit
EOS byte	0Dh
Send EOI at end of write	Yes
Enable Repeat Addressing	No

Exit to the IBCONF main screen (ESC or F9) and then exit IBCONF (ESC or F9) saving the configuration to memory as you exit - saving to disk is at the user's discretion.

Now load IBIC, the Interface Bus Interactive Control program.

At the: prompt identify the device to be communicated with

```
:IBFIND DEV1↵
```

The GPIB board will respond

```
id = 32256 (or some similar number)  
dev1 :
```

Now you can communicate with Merlin™ using IBWRT and IBRD commands to write and read data, respectively.

For instance, to acquire a reading from Merlin™ the following sequence can be used. Note that the bold characters are what you enter, the non-bold are responses.

```
dev1 :ibwrt "pr0lr"↵
```

[0100] (cml)
count: 4

dev1 :**ibwrt 'Pd2 2r'**,↵
[0100] (cml)
count: 6

dev1 :**ibrd 12**, ↵
[2100] (end cml)
count: 12
(ASCII codes for .xyzz nnnn.>
data are here)

Notes on above:

- Quotation marks are required.
- Only the "r" is case sensitive.
- "pr0" transfers the current reading to a buffer.
- Count values refer to the number of characters transferred.
- "td2 2" transfers two words starting at location 2.
- "ibrd 12 requests 12 characters equal to the 2 words.
 - Any number greater than 12 is also valid.
 - The "ibrd" is terminated when the > is encountered.
- The data, "xyzz nnnn," is floating point and is broken down as follows :
 - x is the mantissa sign (0=pos, 1 =neg)
 - y is the base exponent sign (0=pos, 1 =neg)
 - zz is the base 10 exponent as a BCD string
 - nnnn is the mantissa as a BCD string with an implied decimal point after the first digit. For example, "01 03 abcd" is +a.bcd millivolts (10^{-3}).
- The > indicates the end of transfer as defined by the "td2 2" . command.

IX. DECLARATION OF CONFORMITY

DECLARATION OF CONFORMITY	
Manufacturer's name:	Newport
Manufacturer's address:	150 Long Beach Boulevard Stratford, CT 06615 USA
Declares that the product:	
Product Name	Merlin Radiometric System
Model Number:	70100, 70102, 70103, 70104, 70105
conforms to the following Product Specifications:	
Safety:	EN 61010-1: 2001 2 nd Edition
EMC:	EN 61326:1998, A1:1998, A2:2001 EN 61000-3-2:2000 EN 61000-3-3:1995, A-1:2001
complies with the following Directives:	
	89/336/EEC EMC Directive 92/31/EEC Amendment 93/68/EEC Amendment 73/23/EEC Low Voltage Directive
and accordingly, carries the CE mark.	
Stratford, CT	 (Signature)
	George Buzel (Name)
	Director of Engineering (Title)

X. WARRANTY AND RETURNS

Newport warrants that all goods described in this manual (except consumables such as lamps, bulbs, filters, ellipses, etc.) shall be free from defects in material and workmanship. Such defects become apparent within the following period:

1. All products described here, except spare parts: one (1) year or 3000 hours of operation, whichever comes first, after delivery of the goods to the buyer.
2. Spare parts: ninety (90) days after delivery of goods to the buyer.

Newport's liability under this warranty is limited to the adjustment, repair and/or replacement of the defective part(s). During the above listed warranty period, Newport shall provide all materials to accomplish the repaired adjustment, repair or replacement. Newport shall provide the labor required during the above listed warranty period to adjust, repair and/or replace the defective goods at no cost to the buyer ONLY IF the defective goods are returned, freight prepaid, to a Newport designated facility. If goods are not returned to Newport, and the user chooses to have repairs made at their premises, Newport shall provide labor for field adjustment, repair and/or replacement at prevailing rates for field service, on a portal-to-portal basis.

Newport shall be relieved of all obligations and liability under this warranty of:

1. The user operates the device with any accessory, equipment or part not specifically approved or manufactured or specified by Newport unless buyer furnishes reasonable evidence that such installations were not the cause of the defect. This provision shall not apply to any accessory, equipment or part which does not affect the safe operation of the device.
2. The goods are not operated or maintained in accordance with Newport's instructions and specifications.
3. The goods have been repaired, altered or modified by other than authorized Newport personnel.
4. Buyer does not return the defective goods, freight prepaid, to a Newport facility within the applicable warranty period.

IT IS EXPRESSLY AGREED THAT THIS WARRANTY SHALL REPLACE ALL WARRANTIES OF FITNESS AND MERCHANTABILITY. BUYER HEREBY WAIVES ALL OTHER WARRANTIES, GUARANTEES, CONDITIONS OR LIABILITIES, EXPRESSED OR IMPLIED, ARISING BY LAW OR OTHERWISE, WHETHER OR NOT OCCASIONED BY NEWPORT'S NEGLIGENCE.

This warranty shall not be extended, altered or varied except by a written document signed by both parties. If any portion of this agreement is invalidated, the remainder of the agreement shall remain in full force and effect.

CONSEQUENTIAL DAMAGES

Newport shall not be responsible for consequential damages resulting from misfunctions or malfunctions of the goods described in this manual. Newport's total responsibility is limited to repairing or replacing the malfunctioning or malfunctioning goods under the terms and conditions of the above described warranty.

INSURANCE

Persons receiving goods for demonstrations, demo loan, temporary use or in any manner in which title is not transferred from Newport, shall assume full responsibility for any and all damage while in their care, custody and control. If damage occurs, unrelated to the proper and warranted use and performance of the goods, recipient of the goods accepts full responsibility for restoring the goods to their condition upon original delivery, and for assuming all costs and charges.

RETURNS

Before returning equipment to Newport for repair, please call the Customer Service Department at (203) 377-8282. Have your purchase order number available before calling Newport. The Customer Service Representative will give you a Return Material Authorization number (RMA). Having an RMA will shorten the time required for repair, because it ensures that your equipment will be properly processed. Write the RMA on the returned equipment's box. Equipment returned without a RMA may be rejected by the Newport Receiving Department. Equipment returned under warranty will be returned with no charge for the repair or shipping. Newport will notify you of any repairs not covered by the warranty, with the cost of the repair, before starting the work.

Please return equipment in the original (or equivalent) packaging. You will be responsible for damage incurred from inadequate packaging, if the original packaging is not used.

Include the cables, connector caps and antistatic materials sent and/or used with the equipment, so that Newport can verify correct operation of these accessories.