

TVGuardian[®] The Foul Language Filter Model 201

User Manual



TVGuardian[®] and TVG[®] are registered trademarks of
Principle Solutions, Inc.

Warning: to reduce the risk of electric shock, do not remove cover. No
user serviceable parts inside. Refer servicing to qualified service
personnel.

FCC regulations state that unauthorized changes or modifications to this
equipment may void the user's authority to operate it.

US patent 6,166,780

THIS PAGE INTENTIONALLY LEFT BLANK

TABLE OF CONTENTS

FCC NOTICE AND WARRANTY INFORMATION	4
INTRODUCTION	6
FEATURES	6
IMPORTANT BREAK IN PERIOD	6
OTHER IMPORTANT THINGS YOU SHOULD KNOW	7
GET TO KNOW YOUR TVGUARDIAN	9
FRONT VIEW	9
BACK VIEW	10
CONNECTIONS	11
CONNECTION TYPES	11
SURROUND SOUND SYSTEMS	12
DVD PLAYERS	12
CONNECTION REQUIREMENTS	12
CONNECTION DIAGRAMS	13
SIMPLE CABLE BOX USING TV RF INPUT	14
NON-STEREO VCR AS TUNER USING TV RF INPUT	15
DVD/VCR COMBO UNIT – USING S-VIDEO AND ANALOG AUDIO	16
DVD/VCR COMBO UNIT, CABLE BOX, AND EXTERNAL SURROUND SOUND AMPLIFIER	17
OPERATION	18
RESETTING TVG TO FACTORY DEFAULT SETTINGS	20
SETTING THE RF OUTPUT	21
USING TVG EXCLUSIVELY AS A CLOSED CAPTION DECODER	21
TROUBLE SHOOTING	22
NO PICTURE AND SOUND	22
A FOUL WORD WAS NOT FILTERED	22
TVG SETTINGS ARE CORRUPT (DEAD MODE)	23

FCC NOTICE AND WARRANTY INFORMATION

FCC NOTE: This equipment has been tested and found to comply with the limits for a Class B digital device, pursuant to part 15 of the FCC Rules. These limits are designed to provide reasonable protection against harmful interference in a residential installation. This equipment generates, uses, and can radiate radio frequency energy and, if not installed and used in accordance with the instructions, may cause harmful interference to radio communication. However, there is no guarantee that interference will not occur in a particular installation. If this equipment does cause harmful interference to radio or television reception, which can be determined by turning the equipment off and on, the user is encouraged to try to correct the interference by one or more of the following measures:

- Reorient or relocate the receiving antenna.
- Increase the separation between the equipment and receiver.
- Connect the equipment into an outlet on circuit different from that to which the receiver is connected.
- Consult the dealer or an experienced radio/TV technician for help.

LIMITED WARRANTY

Principle Solutions, Inc., Makers of TVGuardian[®] the Foul Language Filter warrants that: (a) the product will perform substantially in accordance with the written materials for a period of one year from the date of receipt; and (b) any hardware accompanying the product will be free from defects in materials and workmanship under normal use and service for a period of one year from the date of receipt. Any implied warranties on the product and accompanying hardware are limited to one year. Some states do not allow limitations on duration of an implied warranty, so the above limitation may not apply to you.

CUSTOMER REMEDIES

TVGuardian[®]'s manufacturer's, distributors', and its suppliers' entire liability and your exclusive remedy shall be, at the manufacturer's discretion, the repair or replacement of the product or hardware that does not meet this limited warranty and which is returned to Principle Solutions, Inc. with a copy of your receipt. This limited warranty is void if failure of the product or hardware has resulted from accident, abuse or misapplication. Any replacement product or hardware will be warranted for the remainder of the original period or for thirty (30) days, whichever is longer.

NO OTHER WARRANTIES. To the maximum extent permitted by applicable law, TVGuardian®'s manufacturer, distributors and its suppliers disclaim all other warranties, either express or implied, including, but not limited to implied warranties of merchantability and fitness for a particular purpose, with regard to the product, the accompanying written materials, and any accompanying hardware. This limited warranty gives you specific legal rights. You may have other rights that vary from state/jurisdiction to state/jurisdiction.

NO LIABILITY FOR CONSEQUENTIAL DAMAGES. To the maximum extent permitted by applicable law, in no event shall TVGuardian®'s manufacturer, distributors or its suppliers be liable for any damages whatsoever (including and without limitation, special, incidental, consequential, or indirect damages for personal injury, or any other pecuniary loss) arising out of the use of or inability to use this product, even if TVGuardian®'s manufacturer has been advised of such damages. In any case, TVGuardian®'s manufacturer's, distributors' and its suppliers' entire liability under any provision of this agreement shall be limited any amount actually paid by you for the product and/or hardware. Because some states/jurisdictions do not allow the exclusion or limitation of liability for consequential or incidental damages, the above limitations may not apply to you.

If you acquired this product in the United States of America, the laws of the state of Arkansas, USA, govern this limited warranty. If you acquired the product outside the United States of America, local laws may apply.

Lock Code _____

Date of Purchase _____

Place of Purchase _____

Keep this manual in a safe place.

INTRODUCTION

Congratulations on your purchase of TVGuardian[®], the Foul Language Filter Model 201!

With its sleek modern design, TVGuardian[®] will change the way you experience TV and movies.

FEATURES

- Dual inputs including S-Video and Digital Audio.
- Easy switching between inputs on front panel.
- On screen user setup menu.
- Optional password protection.
- Three different wordsets - each with four filter levels.
- Updated foul language dictionary
- Sleek new design. Works aesthetically with today's audio/video systems and home theater equipment.
- Front panel user interface (no more hard to reach switches).

IMPORTANT BREAK IN PERIOD

The break in period is not for TVGuardian[®] (TVG[®]). It's for you and your family as it may take a few weeks for your family to adjust to the TVG[®] viewing experience. Over the next few weeks, watch several videos or DVDs. It won't be long before you'll wonder how you ever got by without TVG[®]. In fact, our customers tell us all the time that they won't watch TV anymore with out TVG[®].

During your break in period you should consider the following:

- TVG[®] will mute the audio during the entire phrase containing offensive language. It may mute a single word; however, normally it will mute 5-8 words.

- During the mute of offensive language, TVG[®] will display a profanity free version of the phrase in text. When the spoken phrase is completed, the text is erased the sound is restored. The text may optionally be turned off. We suggest you try the factory default settings for a few weeks before changing them.

Examples:

The phrase “*GET THE HELL OUT*” is muted and “*GET OUT*” is displayed.

The phrase “*MOVE YOU’RE A- -!*” is muted and “*MOVE YOUR TAIL*” is displayed

- TVG[®] mutes the entire offensive phrase instead of just the word and displays the modified text, by design. It’s too easy to fill in the blanks in your mind when only a single word is muted. Displaying the profanity free text version of the muted phrase makes your eyes focus on the text instead of the lips. The TVG[®] method makes it more difficult to know what word caused the mute.
- TVG[®] has a 95% average accuracy rate on TVG[®] filtered (closed captioned) programs, but TVG[®] can only be as accurate as the closed captioned text. TVG[®] filters out 100% of the offensive language on many TV programs and movies; however, if the closed captioning is inaccurate on a particular show, TVG[®] will be inaccurate on that particular show.
- Foul words that are normally filtered are missed when closed captioning errors exist (i.e. a foul word is not captioned, misspelled or is not synchronized with the spoken word). Closed captioning is usually very accurate, but some movies and TV shows are full of errors. That’s the exception, not the rule. Watch several videos or DVDs before rushing to judgment!

OTHER IMPORTANT THINGS YOU SHOULD KNOW

- How it works – TVGuardian[®] uses TVG[®] patented technology from Principle Solutions, Inc. to decode and monitor the hidden closed captioned text which is made available for the hearing

impaired. Each word is checked against a dictionary of offensive words and phrases. When an offensive word is detected, the TVG[®] technology automatically mutes the sound, and then turns the sound back on when the phrase is completed.

- Virtually all scripted programs (videos, DVDs, TV series, TV movies) are filtered.

Note: Some companies, such as Universal Studios, may not have closed captioning on all of their DVDs. Please check the DVD case for the CC symbol.

- **Live programming:** Programs using the Rollup style of captioning such as news, sporting events, talk shows, and day time dramas are not filtered.
- **Filter status notice:** This notice is displayed in lower left corner of TV screen briefly after turning the channel, at the beginning of a new TV program or commercial, or at the beginning of a video or DVD movie (after the previews and opening credits):

TVG - Program is filtered

NOTVG – program is not filtered

- To check the filter status and redisplay the filter status notice, simply press **Select**. Either **TVG** or **NOTVG** will appear briefly on the screen.
- Additionally, when TVG[®] is filtering, the **TVG Indicator Light** will be illuminated. Conversely, if the **TVG Indicator Light** is not illuminated, TVG[®] is not filtering the program.
- TVG[®] can be used exclusively as a Closed Captioning Decoder.
- If you currently have a DVD or VCR player with TVG[®] built-in, then we recommend that you disable the TVG[®] feature in the player and use the TVG[®] features of the set top box.
- The Closed Captioning Decoder on your TV needs to be set to **OFF**.

Get to know your TVGuardian®

Front View

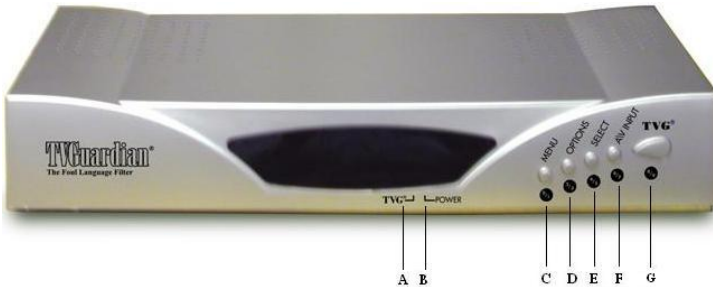

Figure 1

- A. **TVG indicator light**
- B. **TVG power indicator light**
- C. **Menu** also the **0/1** button
- D. **Options** also the **2/3** button
- E. **Select** also the **4/5** button
- F. **A/V Input** also the **6/7** button
- G. **TVG®** also the **8/9** button

Back View

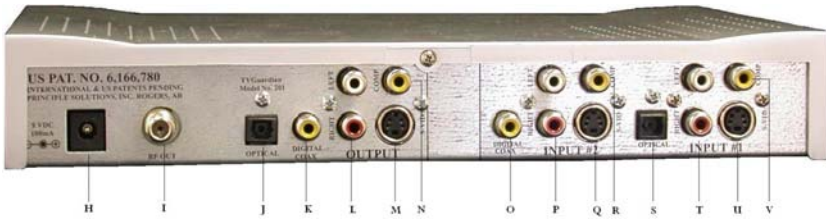

Figure 2

- H. 9 VDC power supply input
- I. RF Output
- J. Optical Digital Audio output
- K. Coaxial Digital Audio output
- L. Right and Left Analog Audio output
- M. S-Video output
- N. Composite Video output
- O. Coaxial Digital Audio input 2
- P. Right and Left Analog Audio input 2
- Q. S-Video input 2
- R. Composite Video input 2
- S. Optical Digital Audio input 1
- T. Right and Left Analog Audio input 1
- U. S-Video input 1
- V. Composite Video input 1

CONNECTIONS

There are many different ways to connect TVG[®] depending on whether you have a cable box and a VCR, or cable with no cable box and a VCR, or possibly a DVD player, or maybe a stereo or surround-sound receiver, or you could have only a VCR and an antenna, you may even have all of the above or...anyway, you get the idea.

Several connection examples are described in this manual. One of them may or may not look exactly like your home equipment. Most likely, one or more of the diagrams are close to what you have and can be used as a guide.

CONNECTION TYPES

TVG[®] can be connected to your TV using RF jacks (coaxial cable), audio/video (RCA-type) jacks, or S-Video.

Using a simple RF coaxial cable connection gives you good picture quality with mono sound. This connection type (figure 3) must be used if audio/video connections are not available on your TV. When using the coaxial cable connection your TV should be tuned to channel 3 or 4. (Note: TVG[®] default setting is channel 3.)

If your TV is equipped with audio/video connections, it is highly recommended that you use them to get even better picture quality and Hi-fi stereo sound. When using the A/V connections your TV must be set to the proper input, not channel 3 or 4. Normally, the proper input can be selected using your TV's remote by pressing the input button. However, you may need to select it on your TV's front panel buttons, or through your TV's menu system. It might also be selected by turning to channel 00, 90, 91, 92, 93, VID 1, or VID 2. The proper input's name and selection method varies from TV to TV. (You may want to refer to your TV's user manual.)

SURROUND-SOUND SYSTEMS

TVGuardian[®] will mute all digital audio formats. However, there may be a slight delay when the digital audio is unmuted. If your surround sound amplifier causes an excessive delay that is bothersome, you may want to use an analog audio connection. Your TVGuardian[®] set top box will not selectively mute the center channel.

DVD players

TVG[®] works with most DVD players. A few DVD players, however, have been discovered to strip the closed captioned signal required by TVG[®] to detect the foul language. If your DVD player comes with “Progressive Scan,” you must turn this function off for TVG[®] to work properly.

CONNECTION REQUIREMENTS

- TVG[®] must be connected *in-line between* your VCR/cable box/satellite receiver/DVD player, and your TV and stereo/home theater system (if applicable). **Therefore, TVG[®] will not work on TV/VCR or TV/DVD combo units.**
- If you are using your VCR as your tuner, TVG[®] must be connected to your VCR as illustrated in the following diagrams. Your VCR will need to stay on when you’re watching TV, and you must change channels on your VCR.
- Your TV must be tuned to either channel 3, 4, or aux/video input depending on whether you’re using a coaxial connection or A/V connection from TVG[®] to your TV.
- Changing channels – you will not change the channel on your TV. You will use your VCR, cable box or satellite receiver to change the channels.

CONNECTION DIAGRAMS

Depending on the particular type of equipment you have in your home, you may have to refer to more than one of the diagrams in this manual. Please use them as a guide. You may also want to refer to the manuals for your VCR, TV, DVD player etc. If you've tried your best but did not succeed, please call us for installation assistance at 479-521-7689 or visit us on the Internet at www.TVGuardian.com.

Diagrams shown in this manual are for the following connections:

Figure 3 - Simple Cable Box using TV RF Input

Figure 4 - Non Stereo VCR as Tuner using TV RF Input

Figure 5 - DVD/VCR Combination Unit using S-Video and Analog Audio connections

Figure 6 - DVD/VCR Combination Unit, Cable Box, and External Surround Sound Amplifier

Remember, for your particular system you may have to refer to one or more of these diagrams.

NOTE: Using both S-Video and Composite Video on the same input at the same time can possibly damage your video equipment and the TVGuardian® set top box.

ADDITIONAL NOTE: If you are going to use S-Video output, you should use S-Video input as well or you may be watching your program in black and white! It is ok to use S-Video input with Composite Video output and you can use both S-Video and Composite Video on the output.

DIAGRAM LEGEND

CV = Composite Video (yellow)
RA = Right Audio (red)

LA = Left Audio (white)
DA = Coaxial Digital Audio (may be orange or black)

SIMPLE CABLE BOX USING TV RF INPUT

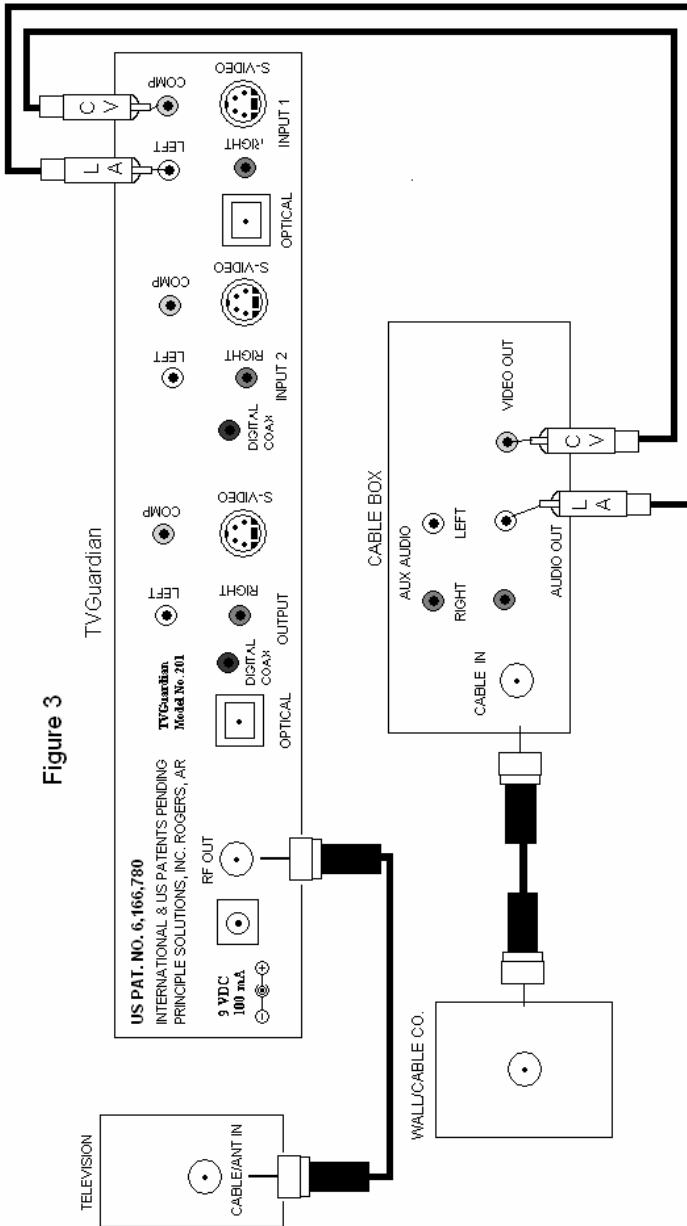

DVD/VCR COMBINATION UNIT – S-VIDEO AND ANALOG AUDIO

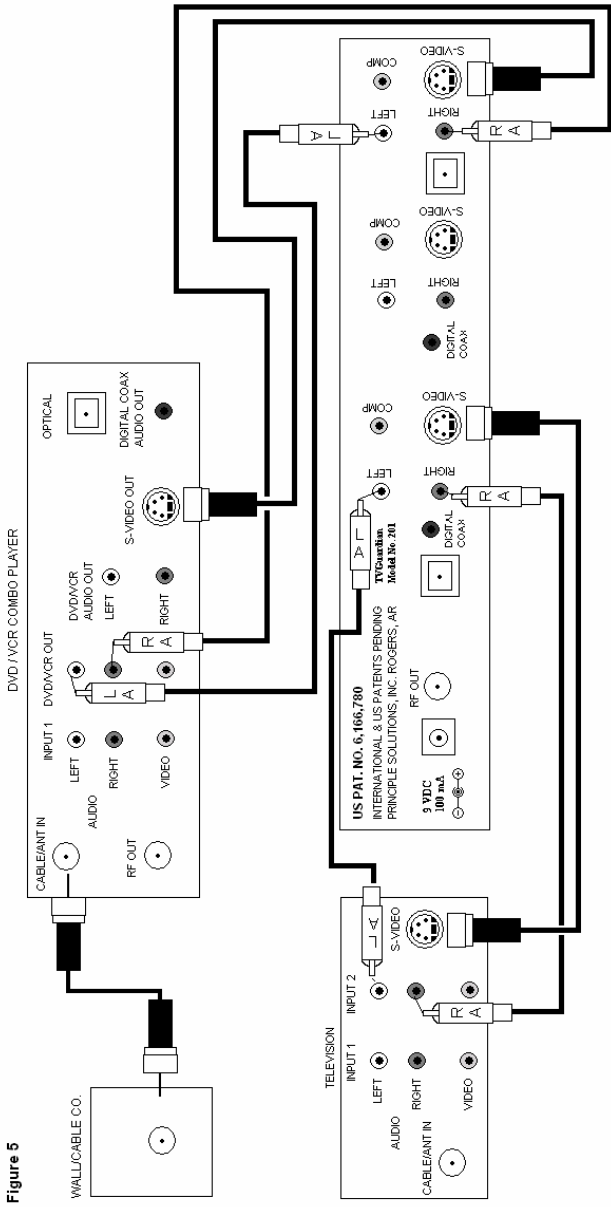
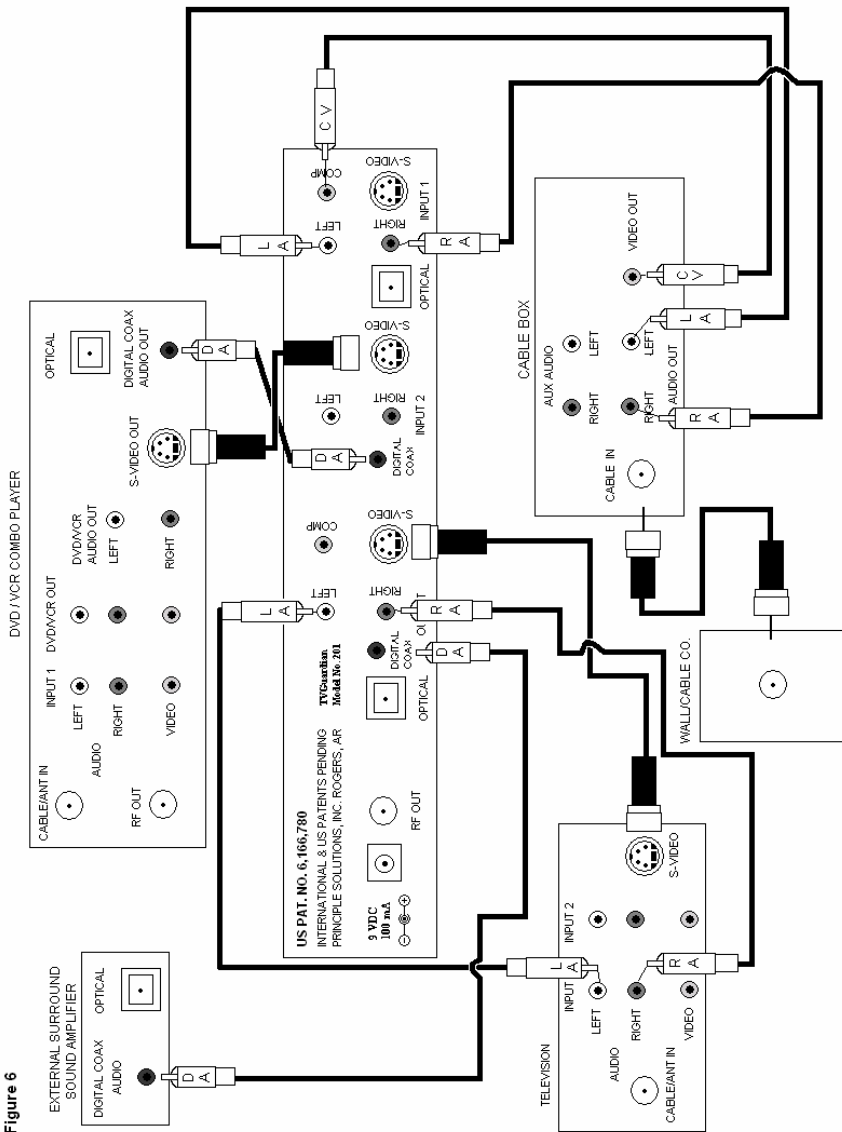
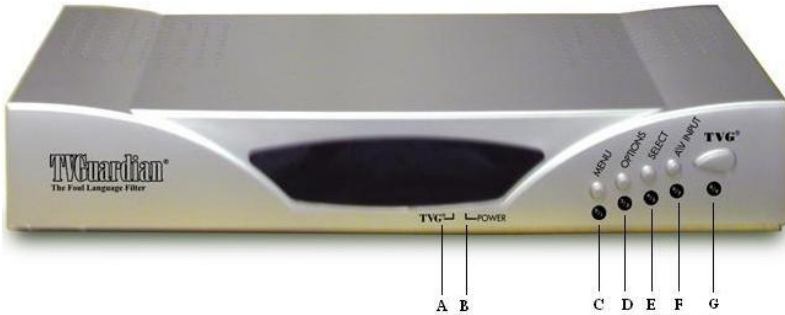

Figure 5

DVD/VCR COMBINATION UNIT CABLE BOX – EXTERNAL SURROUND SOUND AMPLIFIER



OPERATION



Once you have your TVGuardian[®] connected, make sure the red **TVG Power Indicator Light (B)** is on.

Press **Menu** (C). This is what you should see:

TVG Settings Menu				
	(Parents)	(Other)	(Kids)	(Family)
TVG Mode	(Tolerant)	(Moderate)	(Strict)	
CC Mode	(Off)	(On Mute)	(On Always)	
Wordset				
	Religious	(Filtered)	(Off)	
	Sexual Refs	(Filtered)	(Off)	
	Hell & Damn	(Filtered)	(Off)	
Lock Usage	(Menu Only) (Menu and TVG Button) (Off)			
Lock Code	****			

The **TVG[®]** button (G) changes the **Main Menu** setting. You can choose from four different audiences: **Kids, Family, Parents, and Other**.

Within each of these, you can change the settings for **TVG Mode, CC Mode, and Wordset**.

The **Options** button (D) moves you through the choices on each menu.

The **Select** button (E) allows you to change the settings of each option.

If you prefer to use the factory default settings listed in “Resetting TVG® to Factory Default,” just follow these simple steps (Note: you may change the settings of any audience at any time you like):

- Press **A/V Input** to select the video input you want to view, either Input 1 or Input 2.
- Press **TVG** to choose the audience: **Kids, Family, Parent, Other, Off, or Off/CC1.**
- Enjoy your profanity free program.

RESETTING TVG® TO FACTORY DEFAULT

If at anytime you wish to return TVG® to its original factory default settings, you may do so by following these steps:

- While the TV is on, turn the power to TVG® off and then on again.
- When the title screen appears, press **TVG** 5 (five) times in a row.
- Within 5 seconds of being prompted, press **Select**. This will return TVG® to the factory default settings.

Below are the Factory Default Settings:

<u>MENU</u>	<u>TVG MODE</u>	<u>CC MODE</u>	<u>WORDSETS</u>
KIDS	STRICT	ON MUTEALL	WORDSET FILTERS ON
FAMILY	MODERATE	ON MUTEALL	WORDSET FILTERS ON
PARENT	TOLERANT	ON MUTEALL	WORDSET FILTERS ON
OTHER	STRICT	ON MUTE	RELIGIOUS OFF; ALL OTHERS ON

The factory default Lock Code is: 3-5-7-9.

The factory default RF channel setting is 3.

SETTING THE RF OUTPUT CHANNEL

If you are using the RF Output connection to your TV, you may want to change it from the default channel 3 to channel 4 (for example, if you have a local broadcast station on channel 3 in your area). To change the RF Output channel, follow these steps:

- While the TV is on, turn the power to TVG[®] off and then back on.
- When the title screen appears, press **Select** to toggle from channel 3 to channel 4.
- Simply wait for the title screen to time-out and TVG[®] is ready for use.

USING TVG[®] EXCLUSIVELY AS A CLOSED CAPTION DECODER

If you prefer to use TVG[®] as an external closed caption decoder only, follow these steps:

- Press **A/V Input** to select the video input you want to view, either Input 1 or Input 2.
- Press **TVG** to choose the audience: **Kids, Family, Parent, Other, Off, or Off/CC1**.
- Chose **Off/CC1**.

TROUBLESHOOTING

No picture and sound

- Check that the wall power supply is plugged in to the electrical outlet.
- Check that the power supply connection is securely plugged into TVG[®], and that the **TVG Power Indicator Light** is on continuously.
- Check that the audio/video connections are secure.
- Check that the connections are secure and your TV is tuned to the proper input.
- Check that the optional audio/video connections are secure.

A foul word was not filtered

- The program you are watching is either not closed captioned or the captioning is not synchronized with the audio (live TV, news, sports, talk shows, daytime dramas using roll-up style of captioning). You may either switch the channel and then switch it back to the original program, or turn off your VCR/Cable Box and then turn it back on again.
- The program is being filtered, but there are captioning errors (words left out, misspelled, not synchronized with the audio, or the closed captioning is corrupt).
- The word is not in the TVG[®] dictionary.
- The **TVG Mode** is not on a strict enough setting.

TVG[®] Settings Are Corrupt (DEAD Mode)

If the internal, non-volatile memory fails, it will cause TVG[®] to fail. It is very unlikely this event will occur, but if it does, you will see the following screen:

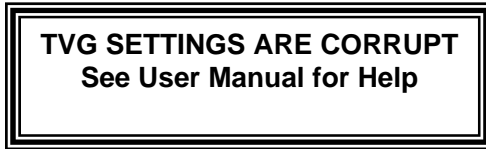

- This message will clear after about 25 seconds and TVG[®] will go into **DEAD Mode**. While TVG[®] is in **DEAD Mode**, you may continue to watch TV. The **TVG Power Indicator Light** and the **TVG Indicator Light** will flash continuously indicating TVG[®] failure. If this occurs, try resetting the non-volatile memory by following the steps in “Resetting TVG[®] to Factory Default.” If this does not correct the problem, call technical support.

TVGuardian[®]

The Foul Language Filter

US Patent Number 6,166,780

TVGuardian[®] and TVG[®]
are registered trademarks of
Principle Solutions, Inc.

Technical Support:
(479) 521-7689
support@tvguardian.com
www.tvguardian.com

Principle Solutions, Inc.
P.O. Box 670
Rogers, AR 72757
USA