

USER'S MANUAL

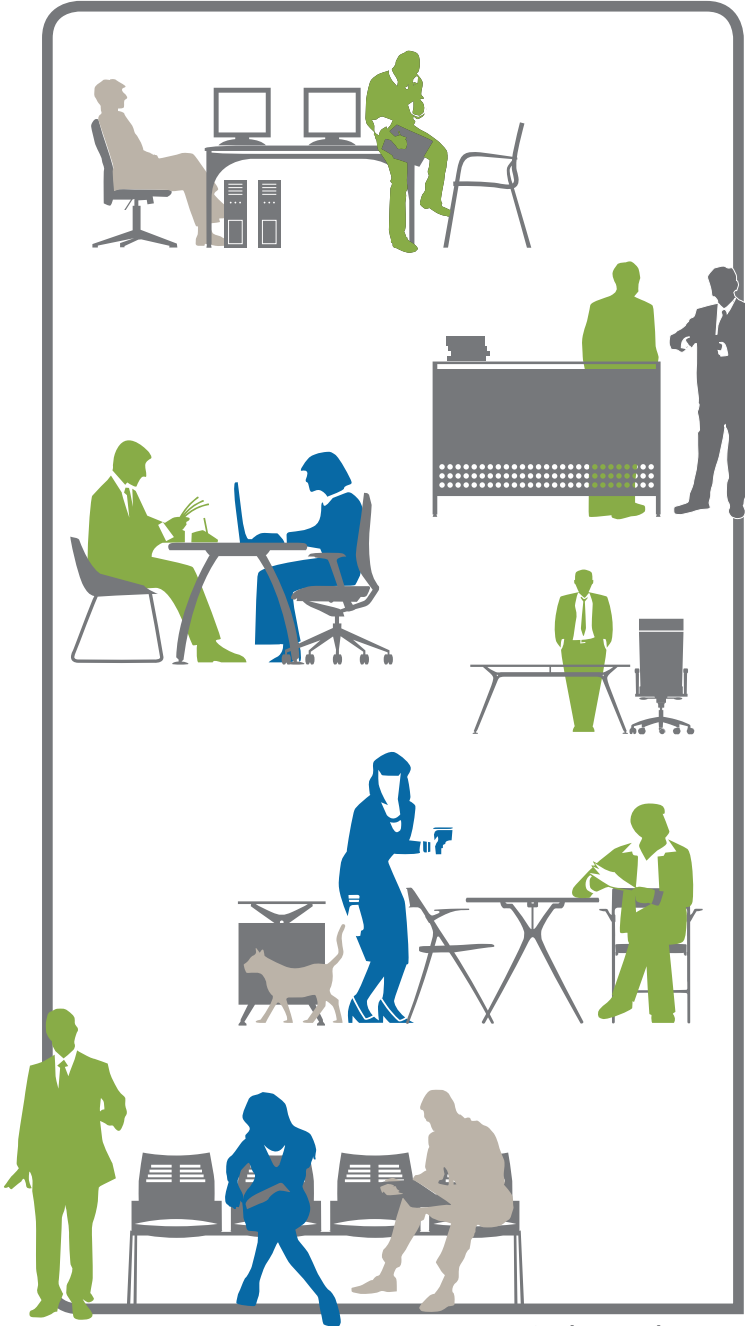

revised November 2011



User's guide for Office Furniture Ergonomics, Use and Conservation

User's guide for Office Furniture Ergonomics, Use and Conservation

November 2011



chairs



tables



storage



screens

introduction

This publication is for all those users that are related to office furniture. We have collected and organized a series of National and International rules that affect the characteristics and functions of office furniture.

The rules are not obligatory to follow but we think that it is increasingly more necessary to standardize to help the prescriber select between the vast range of products that exist on the market today; and each day, to a greater extent, the compliance of these rules are demanded by the users.

On these pages, that data has been outlined to facilitate the good use of furniture that Actiu offer, and therefore must not be used to substitute the rules governing these uses.

index of contents

a ergonomic in work spaces

b conservation of materials

c use of office furniture

01 chairs

02 tables

03 storage

04 screens

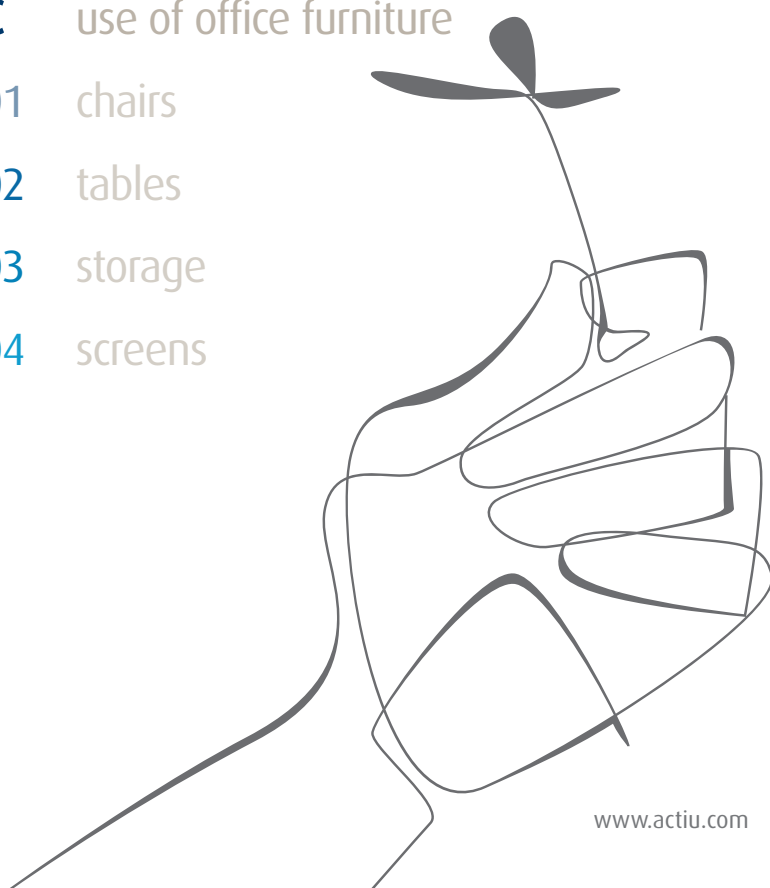

a

ergonomics at Workspaces



ergonomía

Workstations should be adaptable to the greatest number of potential users to meet the various tasks that are currently in the office.

The election and configuration of office furniture should offer a good adequacy and adaptability for the tasks that are developed in any office and the particular needs of workers.

The regulation intervals or fixed dimensions does not include all the variations of anthropometric measures of all the users since this would complicate matters but encompasses the majority of the workers.

The table is probably the element with the biggest ergonomic impact on workstations with computers. The characteristics of this type of task associated with this type of workstation (intense use of the computer/ concentration to analyse information etc), determine that on occasions they design workstations with a limited amount of space.

Nevertheless, the desk and work surroundings must be favourable to the opposite aspects, motivating mobility and changing posture to avoid the tendency to be static. For this reason, the desk must be combined with comfort and must allow the adoption of different comfortable postures, versatile so that the distribution of elements and a level of mobility avoids the problems associated with monotone and static physical work.



a _ ergonomics at Workspaces

introduction

Health prevention, a future investment

Every day there are more and more people working in offices and less people doing hard physical labour. This fact would suppose an automatic improvement in public health , but the statistics show that back pain is the biggest work related illness (13% and an average of 22 sick days. “Federal Association of Mutuas” source. The direct cost giving rise to society and the company is work related illnesses, absence times and the decline of production of the worker, as well as, the indirect cost of treatments, of which all could be overcome with a good prevention. The prevention of risks associated with the activities in this sector should be aimed at achieving the following:

Healthy Organisations_ allowing the prevention of psychosocial risks already known as well as those associated with new forms of work.

Healthy Environments_ in which the work conditions result in the optimal from the point of view of health, well being and improvements in productivity.

Healthy teams_ adapting to the needs of the users and the characteristics of the tasks which will develop.

All of these objectives fall into what is now called the ergonomic office but ..

What is actually an ergonomic office?

Nowaday it seeks to arrange jobs so that the workers are comfortable in their office. An **Ergonomic Office** should comply with a series of requirements optimal for the workers.:

- That...**
- ... the Social Relationship will be more human
 - ... the Work Conditions will be the maximum optimal
 - ... the workplace complies with a series of rules that allow their users to do their jobs and perform their functions in an optimal way for health.

People who work in offices already spend around **80.000 hours seated** throughout their working life, which can provoke back injuries if one is in an inadequate position or with a bent back.

It is easy to maintain these positions over a period of time because there is low muscular effort, over time, the injuries could be dangerous.

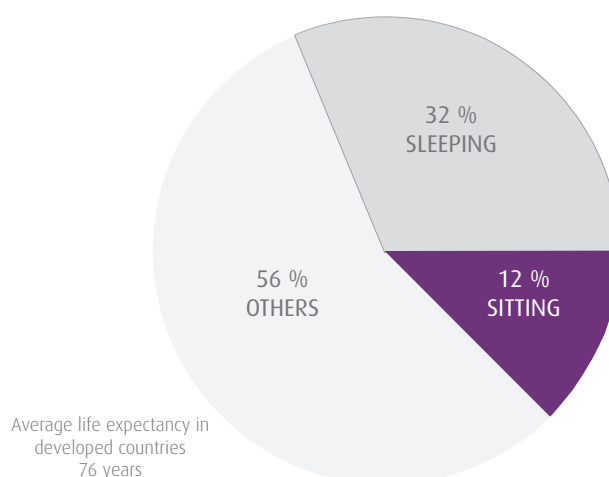

SITTING INCORRECTLY AFFECTS:

Intervertebral discs
Musculature
Impaired metabolism

Circulation
Stomach and Intestine alterations
Pins and needles in the legs
Tiredness
Stress

It is essential, that the work activities ensure that the optimal conditions are carried out and that the jobs are adjusted to the comfort of the workers. Therefore **chairs, tables, other office furniture**, such as the use of computers and other habitual peripherals in the offices, must comply with a series of rules, in order that the final user is comfortable in their place of work..

Training is necessary to show end users how it is or how it must be the correct posture in the workplace, after all, are those which prevent their health, they ensure a future improvement.



a _ ergonomics at Workspaces

workplaces Evolution of jobs and typology of users

Evolution at the workplaces

Change factors in the office and in office furniture:

- **Technological Progress_** More powerful and efficient tools. All the work processes integrate into this. (basically in personal computers).
- **Specialization of workers_** Now all the processes are centralized into one tool, it is necessary that the users know how to control the different processes well.
- **Horizontal hierarchy_** Each position covers more tasks and it is not necessary to have so many people coordinating the different departments in the company.
- **Work Team & more Accesible Communication_** Application of Open Space Workplaces. As there are fewer staff, the treatment should be more direct and everyone should work together to coordinate properly.

Consequences of the changes:

- **Customer service desks or 'call centres'_** Telephone, computer and internet act as a way of decentralizing the companies geographically
- **Telecommunicating or home working_** The job stays at home and each time becomes more practical with Home Office as an alternative.
- **Physical less space_** The environment where the job is situated makes the office furniture adapt to new situations.

In terms of office furniture, **there isn't any existing model that is the best** because the adaptability of all the office furniture varies according to the use of which it is intended. The different jobs establish different types of tasks, with which the furniture varies according to which type and therefore the furniture is adaptable to the tasks of the users. Each combination needs some different characteristics.

We are able to simplify these positions into 4 different blocks:

1 Management Jobs
Positions of command.



- Activities
- Studio and analysis of information
 - Less computer use
 - Meetings

Aesthetics image prevails over the ergonomic aspect.

2 Technical positions
Tasks with greater autonomy and intellectual charge.



- Activities
- Intense use of the computer
 - Increased postural load

High quality ergonomic furniture.

3 Administrative Jobs
Tasks with less autonomy and less creative character.



- Activities
- Computer work
 - Management of an abundant amount of information on paper

It takes into account a level of ergonomics.

4 Customer Service positions
A variety of positions



- Activities
- Direct contact with the public
 - Information desk, calls etc ...

The positions are more versatile and accessible according to the task.

Whatever the place of use or employment destined, the office furniture must comply with basic requirements and obligations, , **to guarantee that during their use there will not be any accidents and furthermore must be robust enough to provide assurance that it can perform the job that is required.**



a _ ergonomics at Workspaces

Health prevention Associated risks in the office

Disorders, musculoskeletal, visual fatigue, headaches, thermal discomfort, monotony, lack of motivation, stress...

The problems are divided into three large groups according to the source of the cause:

- 1 **Postural load**
Static postures- musculoskeletal problems.
- 2 **Work environment**
Lighting · Temperature · Humidity · Noise exposure ...
- 3 **Psychosocial**
Stress · Mental Load · Motivation ...



- **Adequate management** (design of offices, office furniture, teams adapted to the necessities, good training of the workers, correct organization of the tasks, ...)
- **Knowledge** about the measures needed to avoid the problems related with postural load.

One must put aside that the ergonomic problems are only given by 'incorrect posture', because in recent years, new factors are being considered, like postural mobility, the possibilities of personalisation, adaptation to the different activities within the scope of the job and the organisation of the job.

Sitting 6 hours or more a day makes one 40% more likely to live 15 years less than people who sit less than 3 hours. Even if, you do exercise.

The discomfort of musculoskeletal

Physical inactivity, intensive work, little space for mobility, bad posture over a prolonged period of time, therefore the high pace of work provoke fatigue and numbness.

We highlight 5 principal areas where we have detected these symptoms:



Neck

- **Neck** _ Asociado a malas posturas del cuello, colocado de forma girada o demasiado flexionado/extendido. Normalmente se produce por mala colocación de la Pantalla o de la superficie de trabajo.



Shoulders

- **Shoulders & Upper Back** _ Shoulders and upper back- associated by upper muscular effort of the girdle. They are mainly related to no support on the forearms at the time of typing or using the mouse or the elevation of the shoulders if the desk is too high.



Back

- **Back** _ To sit, the back posture is totally changed in respect to when one is standing. The pelvis maintains a slight incline forwards, supporting the column in the lumbar region. (Forming a double S) If the chair doesn't allow different postures (high back chairs and rigid) and doesn't allow good back support and if the desks are too high or too low, this will cause discomfort in the back.



Hands

- **Hands & Wrists** _ They are less common problems and they occur principally due to the bad position of wrists (very extended upwards, flexed downwards or deflected). This is a result of the position of the keyboard, very high or inclined desks too high or prolonged tasks of imputing data onto computers.



legs

- **Legs & Knees** _ The problems occur over a prolonged time of sitting down and cause numbness in the legs. Normally it happens if the chair is too big for the user where the edge puts pressure on the knees or bad position of the knees during ones work.



a _ ergonomics at Workspaces

Health prevention Requirements in workplace elements

Minimum ergonomic requirements



Table

Sufficient **dimensions** to place work objects loosely on it.

Finishes of the **surface in matt**, to avoid reflections and preferably in soft colours (not very light or very dark).

Low thermal transmission in the contact parts of the user and free of edges and sharp angles.

Space under the desk to allow mobility and to ensure a comfortable position for the user.



Chair

The seat should be adjustable in depth in a range necessary for a different population of users.

Back with lumbar adjustment and height and incline adjustments.

Base with 5 spokes to give stability to the chair.

Adequate wheels for each type of floor.

Covers of the chair made from breathable materials.

Comfortable incline of the seat and the edge with no pressured hamstring.



Lectern

They must be adjustable in height, incline and distance. The support for the document must be opaque and with a low reflective surface. It must possess sufficient resistance to hold the weight of the document without fluctuation.



Footrests

They must be provided when deemed appropriate and requested by the users. They must be adjustable between 0-15° horizontally and their dimensions must be minimum 45cm depth and 35cm long.

Spaces in the working environment

There must be sufficient space to allow access and free movement of the user without difficulty. Behind each desk there must be a minimum of 115 cm space to move the chair, facilitating change of posture and movement of the chair. The hallways should be at least 1.5 metres and the walk areas between positions at least 80 cm; therefore creating an environment with little overlapping and freedom to move amongst themselves.

As seen, each day, the office tends to be a work place more 'humanized', where the user can sit comfortably carries out their tasks. Furthermore, the office is changing; already it is no longer just a mere space for containing workers and a series of specific tasks. **Today, we desing more human and flexible companies, creating an environment where people can enjoy themselves, express themselves and personalize their work space, ...**





a _ ergonomics at Workspaces

Health

Practical exercises to maintain a healthy state

Healthy and sensible exercises to carry out, to free the back, the shoulders, the legs, so that we can relax our fixed postures a little in our place of work.

1 Healthy sitting posture

Tense the buttocks and abdominals turning the blades backwards and forwards. Separate your feet at the height of your waist and slightly orientate back. Stretch your head upwards. Inhale through your nose and breathe out through your mouth. Take control of yourself during exercise and correct any incorrect movements. This is very important.

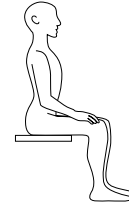

2 Circulation

Stretch both arms forward, with the palms of your hands facing down. Alternately, extend your fingers and make a fist. Your feet must rest on the floor where you can stretch them and alternatively wiggle your toes.

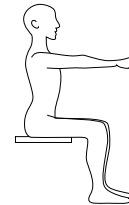

3 Strengthen shoulders, arms and back

At the height of your thorax, press the palms of your hands with the points of your fingers upwards maintaining ten seconds and then loosen. Make circles with your shoulders to relax.



4 Stretching. Lateral cervical musculature.

1) With your head stuck to your chest, carry out semi circle movements; turn your head from one shoulder to another but always passing the chest. Repeat slowly 10 times.

2) Turn your head to the left and stretch your right arm downwards with your palm facing the floor, and the back of your hand facing upwards.

3) The same as before, but turning your head to the right and stretch your left arm. To relax circle your shoulders.

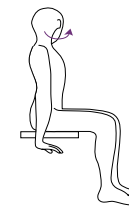

5 Stretching arms and back

Bend the right arm behind your head and the left behind your back. Try to touch your hands together and grab the tips of your fingers. Now try and pull one hand with the other. If your hands don't touch then try the maximum possible. Carry out the exercise inverting the position of your arms. To relax, shake your arms and circle your shoulders.



The exercises are only valid if executed correctly.

6 Strengthen muscles

Extend one leg with the toes facing upwards. Make circular movements with your foot for 10 seconds. After lower the foot to the floor and repeat the exercise with the other leg. For more difficulty, do this with both legs at the same time. To relax place your feet on the floor and then shake them.

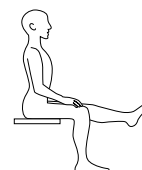

7 Stretch and strengthen abdominals

Put your feet on the floor and support yourself on a chair, flexing the right arm and bend your waist forward halfway down your body. Now lift your left leg and try to touch your knee with your right elbow. After this, stand up straight and stretch your arm and leg until they form a straight line. Repeat the exercise alternatively left side to right side.

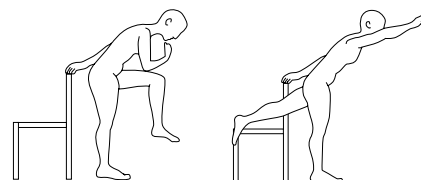

8 Extend arms and blades

Entwine your fingers and place the palms of your hands with extended arms on top of your head. First stretch one arm until you notice a light tension and then the other for 10 seconds repeating a couple of times. Carry out the same exercise, but this time, stretching the arms forward but slightly elevated, carrying out the pressure forwards, first one arm and then the other. To relax shake the hands and then circle your shoulders.

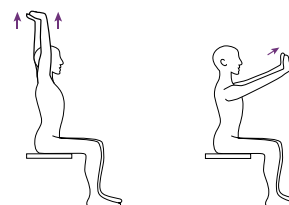

9 Arm and wrist exercises

With your arms extended horizontal, the palms of your hands facing downwards make movements with your wrists, turning them upwards then downwards without moving your arms. The palms of your hands must always be straight. 10 seconds and repeat several times. To relax drop your hands and arms. With your arms extended horizontal gently lift and drop your arms, with an angle of approximately 30° up and 30° down. 15 seconds. Repeat several times. To relax drop the arms and circle your shoulders.

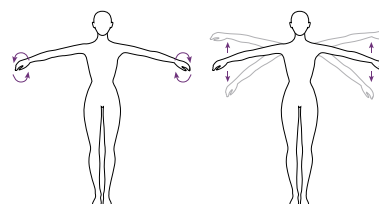

11 Arms and Wrists

With the arms extended horizontal, the palms of the hands facing downwards carry out movements of the wrists, lifting your hands upwards and then downwards without moving your arms. The palms of your hands must remain straight. 10 seconds. Repeat several times. To relax drop your hands and arms.

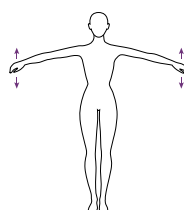

10 Shoulders

In a vertical position, with a straight back and your arms stuck to your body, make gentle movements lifting and lowering your shoulders. To relax circle your shoulders gently.





a _ ergonomics at Workspaces

Health

Advice to avoid physical problems

- The **height of the chair** should be adjusted to transfer the body weight from the buttocks and not from the muscles. Furthermore, the position of your legs should form an angle of 90-100% respect to the floor. The user will be adjusted to suit, to be the most comfortable.
- The **feet** must be completely supported on the floor in order not to use footrests
- The **back** of the chair must be manufactured in a breathable material, and must form a convex in the lumbar of the back and should be high or low enough to reach the shoulder blades, to guarantee total back support.
- The **back** must be adjustable in height and inclination, to give the correct lumbar support. The strength that is adjusted, should be determined by the user, as not all possess the same body mass.
- -It is necessary to be able **to move** and get up every so often because being in the same position for a length of time causes fatigue. This is as important as sitting correctly.
- You should take **eye rest breaks**, respectful of monitoring as it is not only vision fatigue but the rest of your body. Furthermore, the screen should be at least 40cm away in distance and slightly lower than the horizontal line of your eyes.
- The **objects on the desk** should be situated in a way that the user can access them comfortably and without a great effort.

The job should be adaptable to the worker
and not the reverse.

Health

Protect your vertebral column

30 minutes of daily exercise recommended is not sufficient. Interrupt your work in any moment that you can.

Maintain an upright posture

1. Move your shoulders upwards gently.
2. Maintain your head upright with a straight neck.
3. Keep your belly tucked in and stomach muscles contracted.
4. Lengthen your legs forward closing the joints at the knees. In this way, it widens the base of the body mass and reduces muscular effort that tends to balance the body.
5. Support your chin in your hand while your elbow rests on the armrests or on your lap.

When we are not sat down, other ways to keep our bodies healthy exist.

- **Bend your knees** (straight back) when picking up things or carrying heavy loads.
- **Sports**, Choose those that are beneficial for the back. Like swimming (crawl and back), cycling, ski-ing...
(Advisable to do them twice a week)
- **Sleep** in a good horizontal position, resting the vertebral column. You must take care with sleeping positions. It is important to sleep on a firm mattress that is resistance and tense so that we do not sink.
- The **pillow**, as flat as possible, and the way to sleep, facing upwards or on your side with bent legs. Avoid sleeping face down as this does not help your back.

If you have any doubt about the sport which is best for you, contact your physiotherapist for professional advice



Stretches

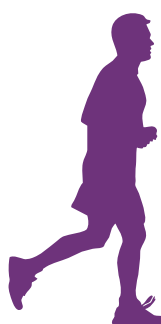

Walking · Jogging



Jumps



a _ ergonomics at Workspaces

Health correct position in your job

While you are spending the day at your desk, you can furthermore add to this the time spent driving to work. Walking, cycling and using the stairs instead of the lift are activities that we favour. Furthermore, we can interrupt the amount of time seated.

Acquire a good position

- 1 Upright head
- 2 Relaxed shoulders
- 3 Straight back
- 4 Front view at all times
- 5 Moderate position on chair
- 6 Arms and legs formed at 90° angles
- 7 Hands in line with arms
- 8 Feet firmly on the floor
- 9 Monitor the visual line in the centre
- 10 Easy access to reading material
- 11 Correct and moderate lighting

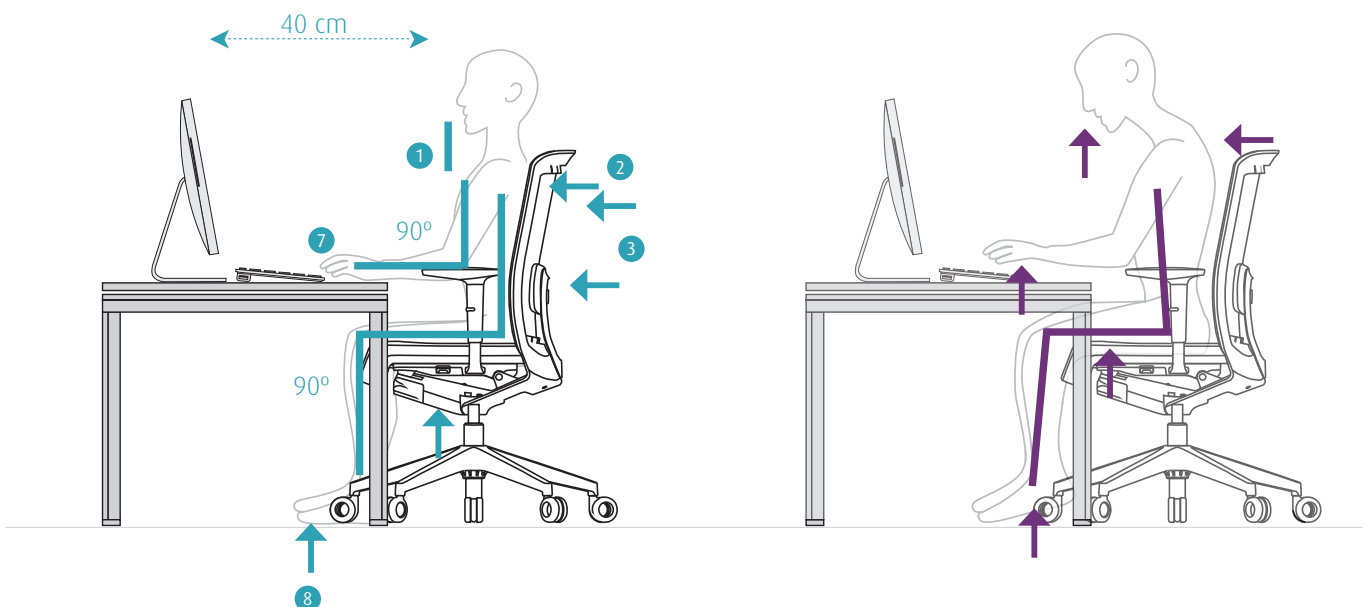

It is convenient to alternate the dynamic and static tasks in your daily work.

Types of jobs

Each task requires some ergonomic conditions and specific mobility

Static work

Analysis and writing of documents, intensive IT work, block the syncro mechanism and use the armrests in the necessary position.

Dynamic work.

Managing and exchanging information, communication and managing peripherals...release the syncro mechanism adjusting the weight and stature. Place the armrests in a lower position.

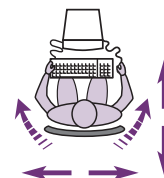

Torsion

Flexible back that accompanies the action of the user's torsion, adapting itself to the normal shape of movement.



To sit in a position of 135° reduces the tension in your back, much more than stooping forwards or sitting upright





a _ ergonomics at Workspaces

environment
environment control
requirements



Sound Environment

For office jobs that demand a certain amount of concentration and a frequent verbal communication, the noise is probably a real problem, it is not an aspect lost on hearing but on comfort.

The principle noises are generated by

the telephones
the machines being used
the conversations

The tradition has been set that they prefer work spaces rather smaller than the larger work spaces because in the latter ones they basically produce a lack of concentration and lack of intimacy

The tradition has been set that they prefer work spaces rather smaller than the larger work spaces because in the latter ones they basically produce a lack of concentration and lack of intimacy.



A big group of factors influencing the conception of jobs are environmental, of which we will only remark on the most important. The environment must be maintained in respect of a direct relationship to the individual and following these factors should be within the limits of comfort with a goal to achieve the highest level of well being and satisfaction.



Thermal Atmosphere

Obtain an appropriate thermal environment in the offices, for this condition you have to study and adapt the air temperature, the humidity of the air, the velocity of the air and the temperatures of the walls and objects.

For this there are some values that help us maintain spaces in the optimal conditions for the comfort of the workers.

optimal conditions of environment	 WINTER	 SUMMER
TEMPERATURE	19-21°	20-24°
REALTYIVITIE HUMIDITY	40-60°	40-60°
AIR SPEEDNESS	0.15	0.25
Dif Ta between 1.1m & 0.1 m of the floor	<3°	<3°



environment environment control requirements

a _ ergonomics at Workspaces



Bright Environments

Choose a good lighting system for the positions to achieve a certain visual comfort and a perception which requires a good study of the following points:

- 1 Good illumination at work station
- 2 Type of task carried out (objects to handle)
- 3 The contrast between movable objects and the surroundings
- 4 The age of the worker
- 5 Arrangement of lighting.

Do not disregard the factors that cause visual fatigue.

For an indication of good lighting in the work areas we will consider the following:

- Lighting equipped with diffusers to prevent direct vision of the lamp
- The lights will be placed in a way that the angle is superior to 30 degrees above horizontal vision.
- The lights will be situated in a way that the reflection on the surfaces does not coincide with the angle of the user's vision.
- Avoid work surfaces with bright or dark coloured materials.
- If one has natural light, one will seek to have an element of protection on the windows that can be adjusted to prevent so much glare and heat from the sun rays.
- The situation of windows will allow external vision.

Colour

In this section you must also take into account the **choice of colours** of the elements that make up the job and its surroundings. The colours possess some determining reflection coefficients and cause some psychological effects on the workers; therefore it is important before choosing a colour of a room, to take into account the type of job that will be carried out there.

Monotone work. It is advisable to use stimulating colours, not on all the surfaces of the building but on small surfaces such as screens and doors etc.

For **jobs** that require a great deal of **concentration** we choose light and neutral colours

We reserve intense colours for places where **the workers will stay a short time**, as long term it will cause visual fatigue, reserving the walls and ceiling of offices in light and neutral colours.

COLOUR		DISTANCE FEELING	THERMAL FEELING	PSYCHIATRIC FEELING
BLUE	▶	REMOTE	COLD	RELAXING · SLOW
GREEN	▶	REMOTE	COLD - NEUTRAL	VERY RELAXING · REST
RED	▶	PROXIMITY	HOT	VERY STIMULATING · EXCITEMENT
ORANGE	▶	CLOSE PROXIMITY	VERY HOT	EXCITING · RSETLESS
YELLOW	▶	PROXIMITY	VERY HOT	EXCITING · ACTIVITY
VIOLET	▶	PROXIMITY	COLD	EXCITING · AGITATION

b

conservation of materials

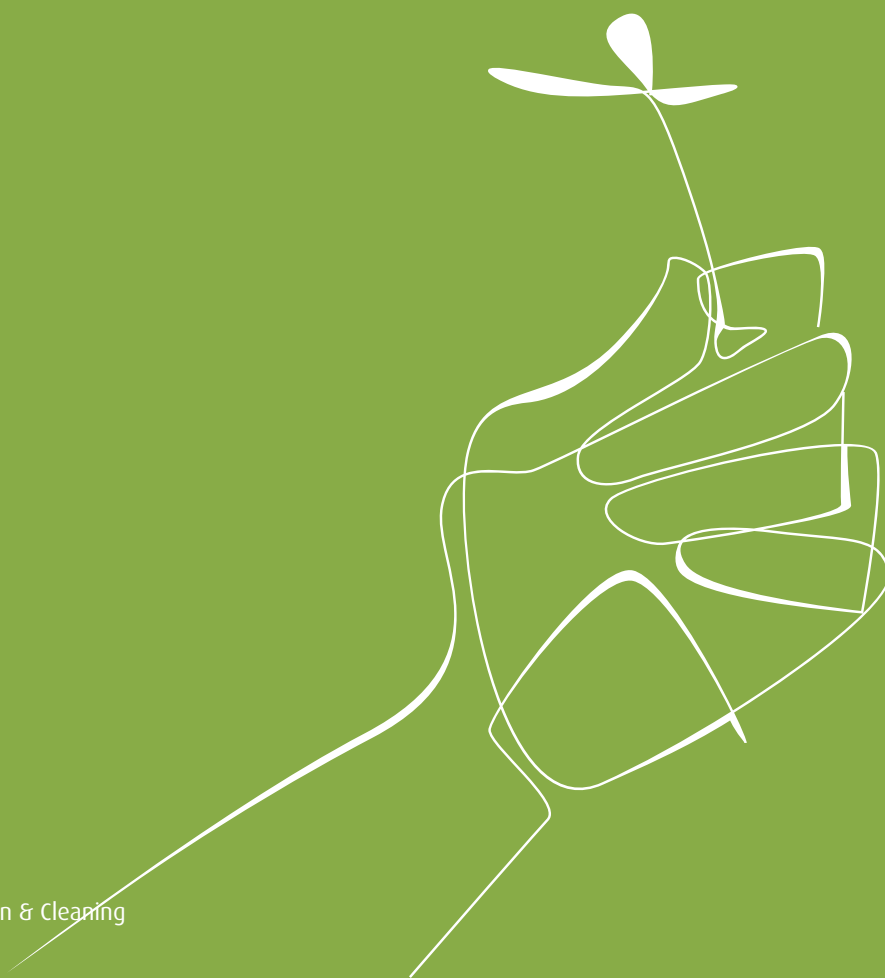



surfaces

materials

wood

fabrics



b _ conservation & cleaning

surfaces general maintenance



Actiu recommends that you always use cleaning products with PH neutral and which respect the environment

Cleaning



Glass

Use a cloth and a spray glass cleaner.



Lacquered and painted components

Use warm soapy water and dry with a cloth



Metalic pieces. Use warm water and mild soap and dry with a cloth. In the case of chairs, cupboards and blocks, avoid the movable parts that may remain wet.



Pullout drawers and cupboards

The sliding rails to the drawers and cupboards do not need lubrication. All these products have been pre lubricated in manufacture to ensure the correct movement during the whole product life. At the time of cleaning avoid getting the sliding rails wet.

Maintenance of the surfaces

Actiu products have been made using a great variety of materials, metal, plastic, glass etc. Follow the advice written for each Actiu product, ensuring the conservation for many years to come, like the first day after its purchase.

General Maintenance

Please clean the surface of your furniture with a damp cloth and mild detergent. We recommend you always use non-polluting cleaning products. Then dry carefully.



b _ conservation & cleaning

materials Actiu materials warranty



Actiu recommends that you always use cleaning products with PH neutral and which respect the environment

ACTIU Guarantee

With a purchase of a product, Actiu offers its distributors a guarantee according to the legal framework, rule 23/2003 10th July Guarantee of Sale of Consumer Goods, therefore the rules are set out by the general law on behalf of the consumers.

Excluded from this guarantee is glass and damages caused by:

- Installation that does not conform to Actiu assembly instructions
- Misuse of a product (any doubt please contact Actiu or write to marketing@actiu.es)
- Wear and Tear of the product or variations of natural colours or textures due to normal use.
- Repairing or manipulating of a product by an unauthorized person
- Use and/or maintenance that does not conform with the manufacturer's:
 - Don't put in direct heat
 - Don't expose to direct sun light
 - Clean with a damp cloth and dry quickly
- Don't use abrasive products such as acetone, bleach and solvents etc

	Comp. Metal NO Mechanics	Ruedas y mecanismos	Upholstery
Office Furniture	Until 5 years	Until 5 years	Until 3 years
Occasional Furniture			
Screens and shelving			Until 2 years
Seating		
Storage & Accesories			

ACTIU RECOMMENDS INSTALLATION OF ALL PRODUCTS BY SPECIALIZED PERSONNEL

Materials used in ACTIU products

Estructures

Melamine Tops	30, 25, 19,16, 10 and 3 mm. width
Metallic's	- Steel or aluminium - Painted epoxy or chrome - Injected in technical plastics (PA+FV), (PP+FV), PS & ABS.
Fitting, supports & iron joints Profiles	Steel, aluminium, zamak and technical plastics Steel, Aluminium or plastic extrusions, epoxy painted, chromed or film coated.

Finishes and accessories

Surfaces	Melamine of 80 gr/m ² wood Melamine of 100gr/m ² smooth Edges coating in PP, PS, ABS and PVC
Upholstery	Fabrics of different qualities, finishes and leathers
Drawers, Interior Accessories & Door signs	Injected in PS
Bases & caps	Injected in plastic PA, PP, PS & ABS. Metals in cast aluminium and steel
Castors	PP, PP+FV and PA+Teflon with and without brakes
Mechanisms of regulation tilt, tension, elevation and closing	Steel + technical plastics Aluminium + technical plastics



b _ conservation & cleaning

wood general maintenance



Actiu recommends that you always use cleaning products with PH neutral and which respect the environment

Cleaning



Water

Dry the surface with a sponge



Drinks

Remove liquid with a **damp cloth** and dry



Grease

Use a damp sponge with a cleaner, rinse and dry



Ink

Clean immediately with alcohol or lemon juice. Some permanent marker pens may leave a mark if it is not cleaned in the correct way

Wood maintenance

The individual characteristics and natural variations of wood make each piece of wooden furniture unique. Follow the instructions written on each Actiu product, ensuring the conservation of many years to come like the first day after its purchase.

Regularly clean

- 1 Clean regularly the dust off the wood to avoid accumulation, which will lose its shine to the furniture.
- 2 Use a damp cloth and warm water with a soft cleaning product all over the surface of the wood. Follow the direction of the grain.
- 3 Use a cloth to dry but carefully.

Do not allow any excess water to remain on the wood. Use a cleaner with no abrasive

Important advices

- yes** Advice Clean with a damp cloth always in the direction of the grain • Use coasters under hot objects • Avoid contact with extremely hot or cold objects • Don't drag objects. Lift them • Remove immediately any liquid and then dry that has accidentally spilt on the surface • Use a protector to write •
- no** Use paper towels that can scratch • Avoid cleaning wood in the opposite way to the grain • Avoid exposing wooden furniture to extreme temperatures or changes in humidity for example placing them near radiators, air conditional vents, humidifiers etc. • Avoid exposure of furniture to direct sunlight • Use of strong solvents • Use of glass or wax cleaners • Use of polishes that leave layers which trap dirt and particles that can scratch the surface and damage its appearance • Avoid allowing liquid to have contact with wood •



b _ conservation & cleaning

fabrics general maintenance



Actiu recommends that you always use cleaning products with PH neutral and which respect the environment

Cleaning

To carry out cleaning we recommend a liquid product or using a sponge especially for leather.



Water

Leather_ Dry immediately, clean with a damp cloth and white diluted vinegar then rinse with water.

Upholstery_ Immediately clean with a damp absorbent cloth. Use a clean absorbent cloth to clean the edges.



Grease

Tar, grease and other chemical products_ use a cloth soaked in meths. Don't smoke and make sure you ventilate the room.



Drinks

Use a mix of 2/3 meths and 1/3 vinegar.



Ink

Pen ink_ Rub gently with a damp cloth to absorb the ink. Afterwards, use a cloth, soap and alkali then rinse. Take special care with those products that contain acrylic, polyamide, and polypropylene.



Wax

Scrape the top layer when the wax is hard. Then iron over it on a medium heat, using blotting paper between itself and the fabric in order to absorb the rest.

Pens, glue, paint and varnishes_
See Grease



Chicle

Use a frozen product especially for chewing gum. (Or an ice cube)



Rust

Use a specific product to remove rust and then rinse.

Maintenance of Upholstery

The majority of upholsteries only need a regular vacuum. With regular maintenance, they can appear as good as new over a period of time.

General maintenance

Upholstery

- 1 Don't expose to sunlight as this will diminish the quality of leather.
- 2 On occasion get rid of the dust with a damp cloth, without getting water on the leather and without excess pressure.
- 3 Don't put leather products near heat (distance minimum 30 cm) so that you don't dry out the leather or make it brittle or hard.
- 4 Twice a year, to keep the leather soft and flexible and to maintain the protective cover against water and grease, we recommend that you try using a soft cleaning product on the leather.

Leather

- 1 Vacuum to eliminate dust and fluff.
- 2 In case of stains eliminate with pressured air or with a powerful industrial vacuum

You can get rid of the small marks with a white rubber.

Important advices



Clean regularly · Act quickly before any spillage of liquid · Use products appropriate in each case · Test cleaning products in a place that isn't visible · In case of a dried mark, dry clean · If you have any doubt contact a specialist before use ·



Do not use bleach to clean upholstery · use a sponge or abrasive cloth · Do not allow the water to soak the foam under the upholstery · Do not use solvents, stain removers, turpentine or tar on leathers · Do not rub the surfaces ·

C

furniture use



01 _ Chairs

02_ Tables

03_ Storage

04_ Screens

01

chairs

Office chairs along with the tables are the elements with the biggest ergonomic impact in the office .

As we have observed, its constructive characteristics and dimensions will influence the posture adopted during work and other factors, like mobility, change of posture and adaptation for different activities.

As we have seen, the use and choice of a good chair is one of the most important factors to take into account when making a job position as it is the best way to eliminate the principal musculoskeletal injuries.

We must give the workers and users of these positions the best training so as they can live a healthy life, and do exercises that without doubt will help to remove some of the loads and stresses of work.



ACCORDING TO EUROPEAN LAW WHICH IS CURRENTLY IN FORCE OFFICE FURNITURE PROVIDES THAT WITHIN CHAIRS TWO TYPES EXIST. ON ONE HAND, WORK CHAIRS OR OPERATIVE OFFICE CHAIRS AND ON THE OTHER HAND VISITOR AND PROFESSIONAL CHAIRS



c_furniture

01 · chairs

operative chairs regulations and movements

A work chair is a chair with a back, with or without armrests and which its seat can be adjusted in height and rotation.

Movements

Sycron mechanism

Support block. Operate using the lever to the left hand side, under the chair. Press the lever up to lock the mechanism and repeat the same action to unlock the mechanism.

Strength regulation of back support. Pull out the knob that is located on the left hand side under the seat and turn it until it reaches the desired strength (turn forward for more strength and back to make it more gentle). The back should be adjusted to weight to provide good support in whatever position and adopt a dynamic posture.

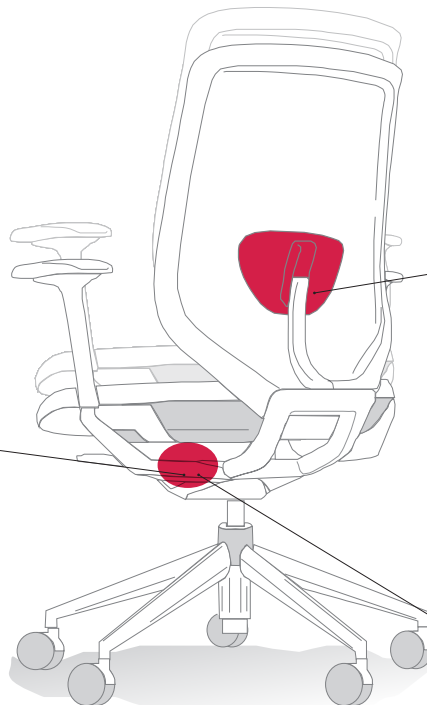
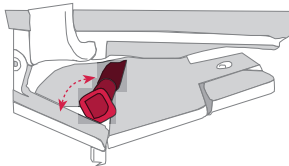

Lumbar Regulation

Available only in Winner 30 and Tnk 40 models.

Winner 30. Moves vertically. Regulator situated on the back of chair.

Tnk 40. Moves Vertically. Regulator situated on the back of the chair or on the sides of the frame.

Width armrests regulation

Only in Winner model.

Possibility of adjusting width of arms using a mechanism situated under the central support of the arm rests.

Mouvements

Back Incline

Actiu work chairs are fitted with an **anti-return system** using 2 functions. The first function controls the speed of the back return using a gas cylinder. The second system is based on shock absorption where the sheer weight of the user exercises the return.

Depth of Seat Adjustment

The mechanism is operated by pressing the lever upwards which is situated on the right underneath the seat. It has a zip mechanism that allows 6 lockable positions. An auto-return system moves the seat to the closest position to the back when it is operated without exerting pressure on the seat.

Height of Armrests

Press the button under the armrests. The arm and forearm will make a right angle to provide the optimal muscle rest. It has between 3 and 5 positions to lock.

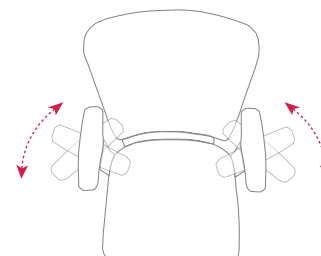

Rotating pivot system of 180 degrees, 3D arms, that allows a clockwise swivel horizontal to the armrests.

Height of Seat Adjustment .

Move the lever that is on the right hand side under the seat and adjust to the height of your choice, increasing or decreasing the pressure. If the height of the seat is adjusted correctly, your muscles and legs form a right angle and your feet rest horizontally on the floor.

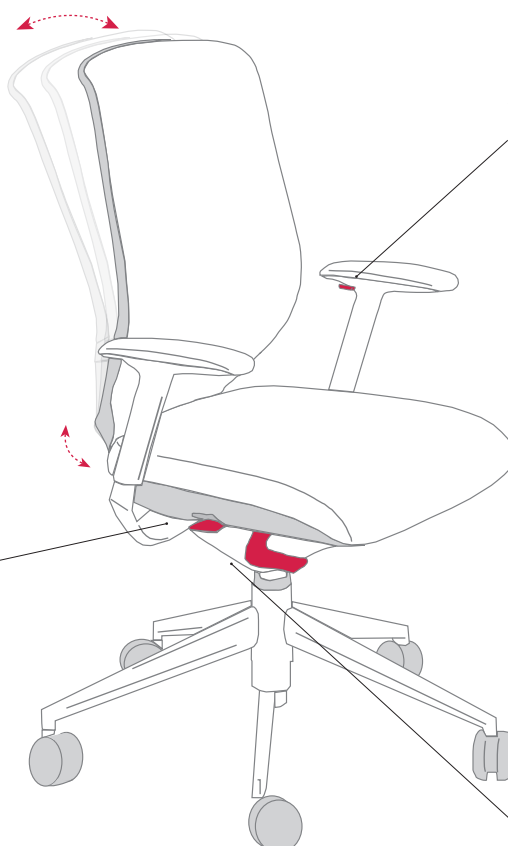



c_furniture

01 · chairs

operative chairs dimensions & requirements

A work chair is a chair with a back, with or without armrests and which its seat can be adjusted in height and rotation.

Armrests

Clear width between armrests

Group A and B 460 - 510 mm
Group C ≥ 460 mm

Useful longitude

Group A, B and C ≥ 200 mm

Distance of leaning edge of seat

Group A, B and C ≥ 100 mm

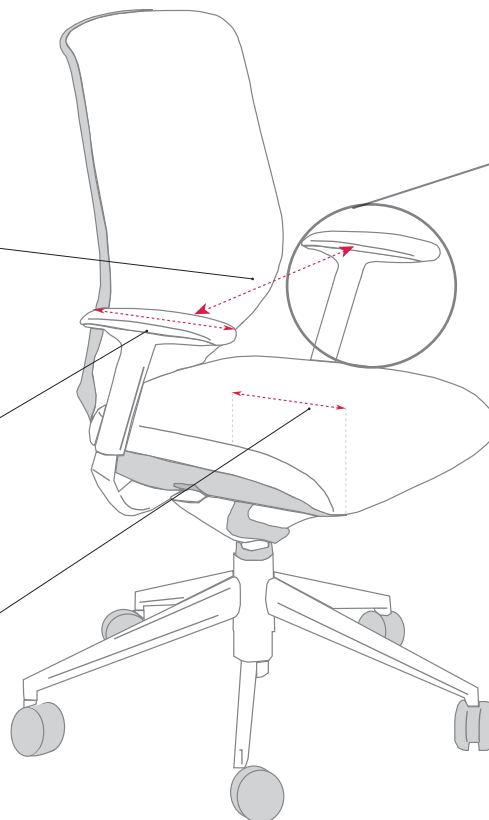

(a) Width

Group A, B and C ≥ 40 mm

(r) Rotation

Group A, B and C 30°

(as) Useful longitude Seat

Group A, B and C Fixed_ 200 - 250 mm
Adjustable_ 200 and 250 mm

European standard for consultation

- EN 1335-1:2000. Office furniture - Office work chair - Part 1: Dimensions - Determination of dimensions

Categories depending on the variety of regulations that chairs have. :

- A.- Chairs that have height and incline adjustments of seat and back .
- B.- Chairs that have adjustments in height of seat and incline of back.
- C.- Chairs that adjustment of height of seat.

Seat · Back

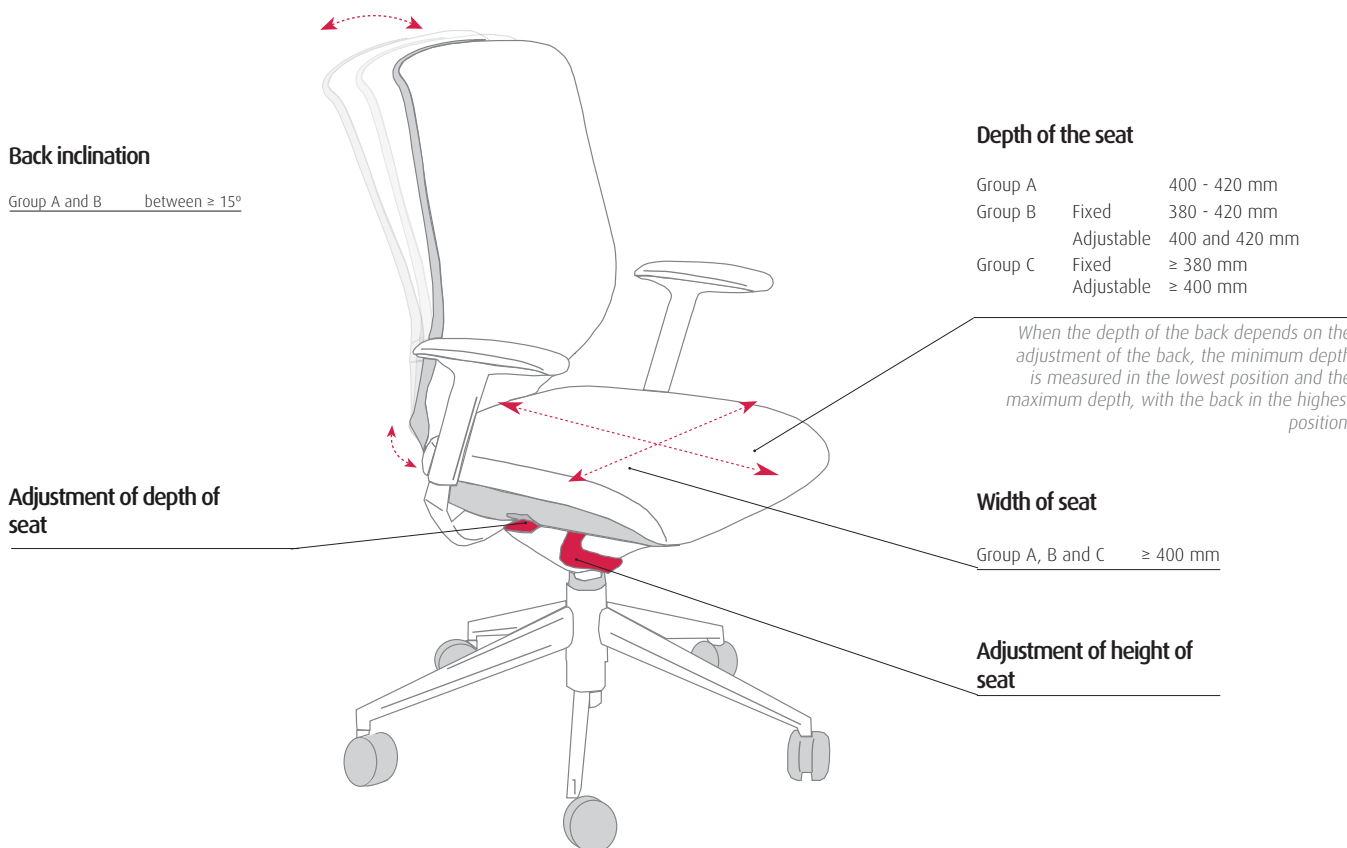
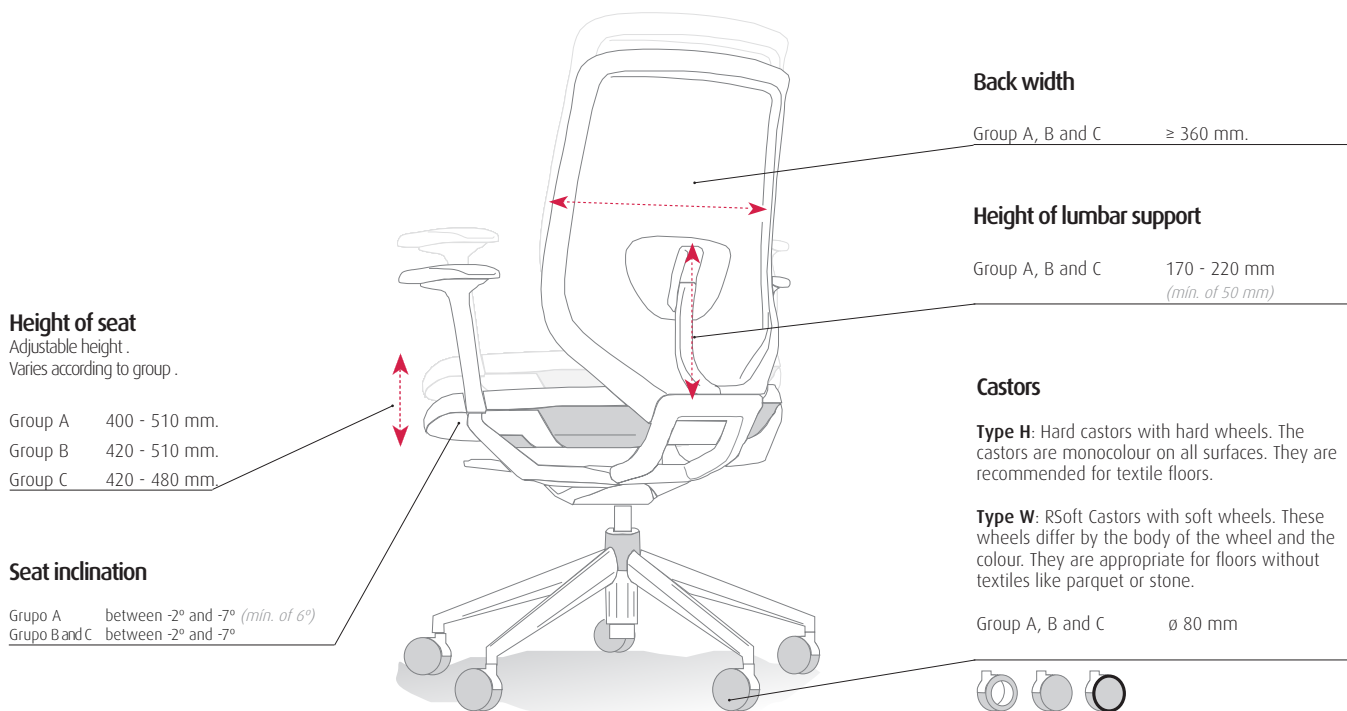



c_furniture

01 · chairs

visitor chair dimensions & requirements

A visitors chair is one that is an individual seat which can be used by different people in the office environment as a complement to the work chairs. They are designed for individual use in meetings, consultations, readings, waiting rooms, libraries ...

Movements

The normal dimensions of these chairs are the same as before for chairs from **Group C**, except for 2 points:

- It isn't necessary that the chair pivots.
- It isn't necessary that the height be adjustable.

If they are fixed its height will oscillate between 400 and 500 mm.

Typology

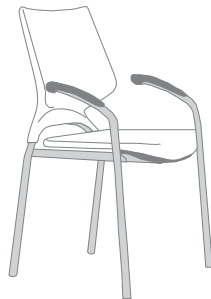

4 legs

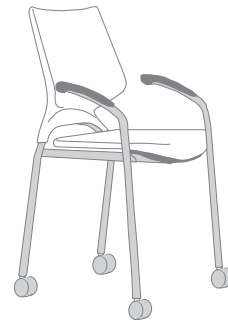

4 legs + castors

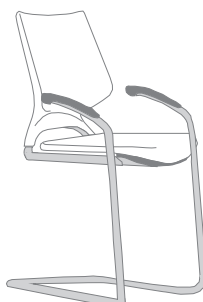

Cantilever



Swivel base

UNE EN ISO 9241-5:1999

requirements for functional



- The **surface of the seat** must be comfortable, allowing complete support of buttocks and muscles. Furthermore, it must be anti-slip and breathable.



- The **back** must provide complete support for the back. It must have convexity that provides a level of mid lumbar area support and it is advisable to be tall, with support for shoulder blades, for positions with an inclined forward posture.

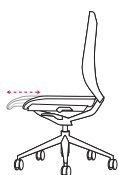

- **Adjustment of depth of seat**, seeking complete support of buttocks and muscles and at the same time the back. In cases that it isn't, you must provide a variety of sizes of chairs with different depths.



- **Armrests** are advisable as to remove weight off the neck and shoulders. They should be sufficient in height to support the arms, but not to be a bother in their position at work. They should be removable or adjustable.



- The **swivel base with castors**, should allow short, comfortable movements that are simple and safe. 5 spokes is recommended to provide stability.

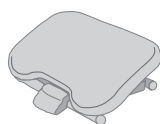

- A **footrest** is advisable, for additional support, change of postures and for those that don't reach the floor. It must be sufficiently big enough, anti-slip and with an adjustable incline.

European standard for consultation

- EN 13761:2003. Office furniture. Visitors chairs.
- EN 1335-1:2000/AC:2002. Office furniture - Office work chair - Part 1: Dimensions - Determination of dimensions
- EN 1335-2:2009. Office furniture - Office work chair - Part 2: Safety requirements
- EN 1335-3:2009/AC:2009. Office furniture - Office work chair - Part 3: Test methods



c_furniture

01 · chairs

use advice

proposals in current
legislation about Office furniture

Like everything in life, the vertebral column ages, so this is constantly subject to a notable degenerative process. The loads, stresses and lack of movement cause the adoption of permanent incorrect postures, furthermore accelerating this degenerative process.

Advice to avoid accidents with chairs

- They must possess a small rolling resistance when the chair is empty, ensuring the impossibility of involuntary movement but without any loss of mobility of the chair.
- **Never use the chair to climb on** to reach high objects. The movement of this on occasions could cause serious accidents.
- **Adjust the chair well** and try it before reclining in the seat. If you do this without adjusting first, it could cause a fright.
- **Check the castors on the chair.** If they are loose, remove the chair and do not use it until it has been repaired or substituted.

And remember...

Before sitting, check the chair is in good condition and is in its correct place.

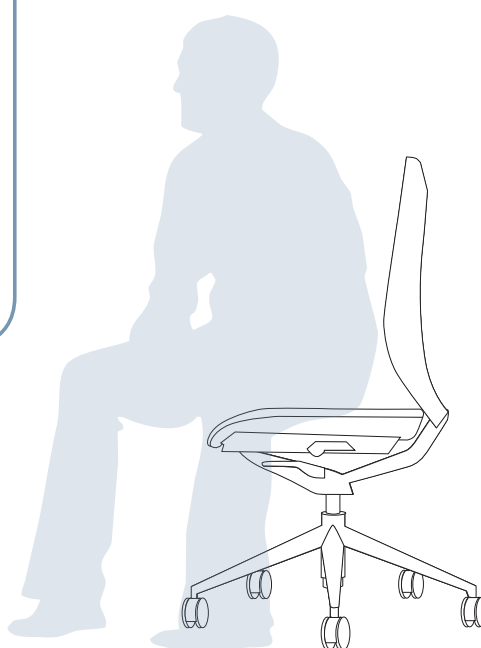

02

tables



OFFICE TABLES FOR GENERAL USE ARE THOSE TABLES THAT ARE DESIGNED TO BE USED BY A VARIETY OF USERS, EXCLUDING OLD OR REPRODUCTIVE TABLES.

A DESK IS DEFINED AS FURNITURE BASICALLY DESIGNED FOR OFFICE WORK TAKING PLACE IN A SITTING POSITION



c_furniture

02 · tables

desks dimensions & requirements

Work surface

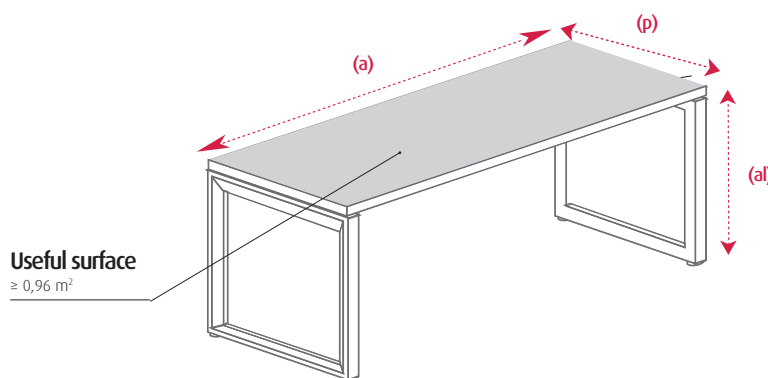

Width (a)

≥ 1200 mm

Depth (p)

≥ 800 mm

Height (al)

Non adjustable desks 705 - 735 mm

Adjustable desks 680 - 760 mm

Mesas de reg. a intervalos fijos ≤ 32 mm

(In adjustable desks, the work surface is measured to 72 cm, and in desks, with a tilted surface, the position least favorable)

Hollow legs

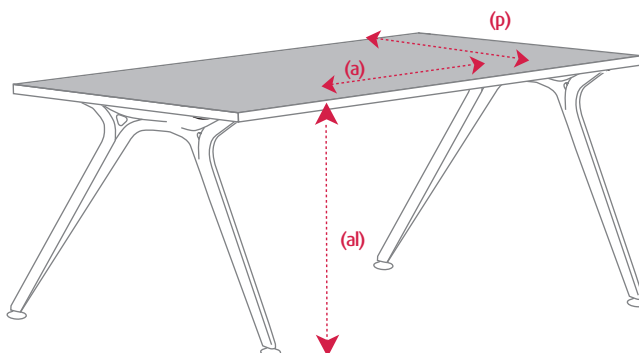

Width (a)

≥ 600 mm

Depth (p)

≥ 800 mm

Height (al)

≥ 650 mm in all its depth
(If not possible, will comply with minimum)

Front Edge

≥ 650 mm
To 200 mm of the edge ≥ 620 mm
To 450 mm of the edge ≥ 550 mm
To 600 mm of the edge ≥ 120 mm

functional table requirements

- **Adaptability of desk** to allow changes in posture and well being of user .
- The **height of the desk** should be enough to permit that the screen be below the horizontal line, but the angle of vision be at <60 degrees on the vertical plane.
- The desk should have sufficient **space to work**. In the case of a computer, the keyboard should be parallel to the edge of the desk with the space between the keyboard and the edge at least 100mm. The screen should be minimum 400 mm away from the user and the angle of vision <40 degrees on the horizontal plane.
- The **material of the desk** must not transmit any thermal feeling of hot or cold.
- The **surface** of the desk should not produce brightness or reflections. They should be finished in satin matt.
- The desk should allow **the access and passing of cables**, without bothering the user.
- It is advisable to have a **document holder/stand**, for those who exercise tasks combined with the computer and documentation.

European standard for consultation

- EN 527-1:2011. Office furniture - Work tables and desks - Part 1: Dimensions.
- EN 527-2:2002. Office furniture - Work tables and desks - Part 2: Mechanical safety requirements.
- EN 527-3:2003. Office furniture - Work tables and desks - Part 3: Methods of test for the determination of the stability and the mechanical strength of the structure.



c_furniture

02 · tables

desks

Prevention semicircular lipoatrophy

This painless and not serious disorder is reversible

Definition and causes

The **Semicircular Lipoatrophy (SL)** is an illness that causes the loss of fat in the tissue in the legs and buttocks. This anomaly in the human body manifests itself by deep marks on the skin, looking like you have left your socks or tights on, on the ankles or muscles. Semicircular lipoatrophy is a rare disorder which its clinical manifestation consists of the lost or atrophy of subcutaneous fatty tissue. Its aesthetic manifestations become bulky in appearance principally forming semi circles on the front part of the muscles

Its caused by ...

- Low humidity
- Concentrated magnetism
- Too many electric devices
- Inadequate furniture
- Faulty cables and earth wire

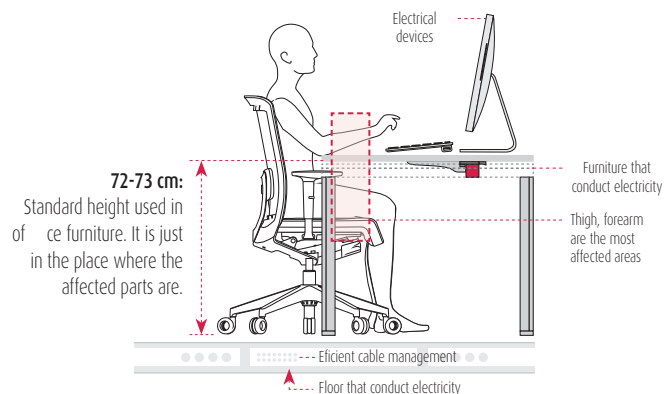

i SL normally appears on people who work in offices with the majority being women (84%).

✓ CAUTION

Materials with no electrostatic charge
Air ionizing
Conduct materials well connected to the ground

✗ AGRAVANTING

Lots of electrostatic charges
No humidity
Not controlled electromagnetic radiations

sistema integrado Actiu de conexión a toma tierra

Electrostatic charge is transferred to the human body by furniture made of electricity conduct materials. To avoid this load Actiu has created **VITAL PLUS ST**, allows us to connect the structure of the earth, eliminating the accumulation of this load and generating magnetic fields, getting rid of any symptom linked to this cause.

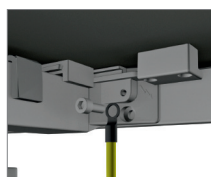

Point of connection to the earth
(Avoiding the accumulation of static electricity)

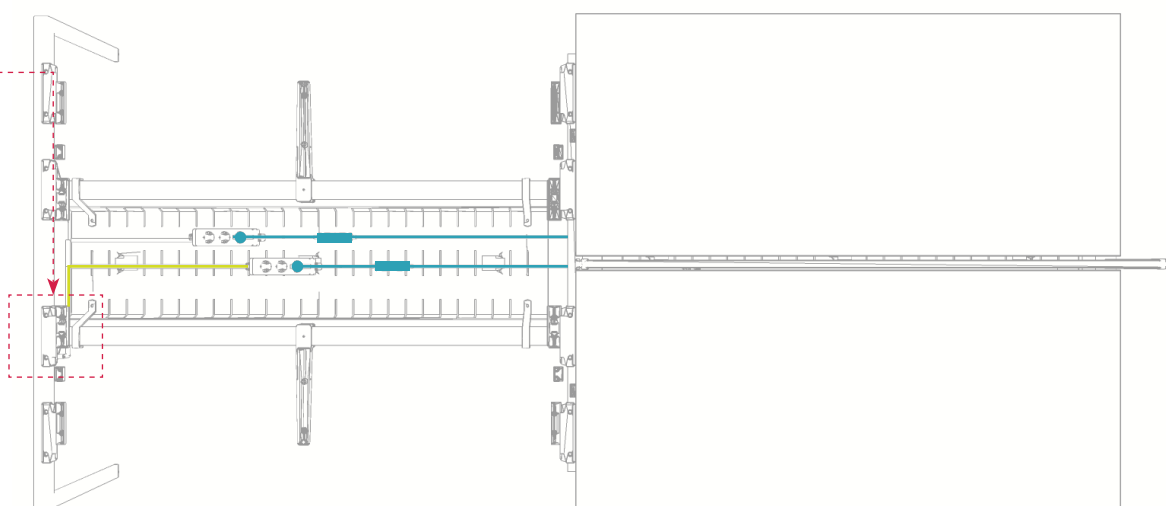

03

storage

Following the European standards for office furniture, office filing is not applicable to mechanical filing systems of high density, or rotary filing or drawing files.

These rules do not contemplate the structural safety of the building (if a cabinet is hanging, the resistance only includes the cabinet and inside and not the wall and its hinges).

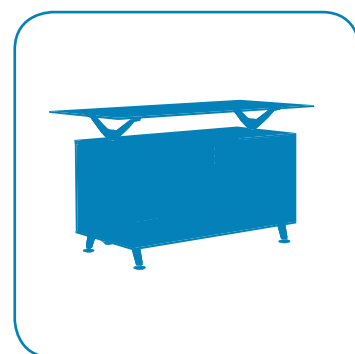

CONSEQUENTLY, WITH THE STANDARDS ESTABLISHED FOR OFFICE FURNITURE FOR FILING, THEY ARE NOT APPROPRIATE FOR MECHANICAL FILING SYSTEMS OF HIGH DENSITY, OR ROTARY FILING OR DRAWING FILES.

IT SHOULD BE ADDED THAT THE RULES DO NOT CONTEMPLATE THE STRUCTURAL SAFETY OF THE BUILDING, THAT IS TO SAY THE RESISTANCE OF A HANGING CABINET ONLY INCLUDES ITSELF AND THE PARTS WITHIN, AND NOT FOR EXAMPLE THE WALL OR THE HINGES.



c_furniture

03 · storage

storage dimensions & requirements

In the rules already established the requirements of safety apply to this type of office furniture, guaranteeing with its design that the risk is minimal under normal conditions

Dimensions

The dimensions that are set out in the rules are based on dimensions of different products to store documents and its most common ones, of which we recommend a certain archive size of furniture for paper documents, paper files and electronic documents.

- If they are next to desks, it is advisable they are the same height (a), and the dimensions are included in the sections of the office desks. The width and length should also be taken into account (b).

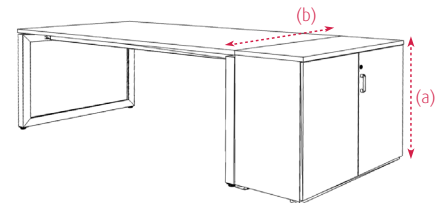

- If it is used next to a divider, then it is recommended that the height of the furniture meets the dimensions that are indicated in the section of dividers

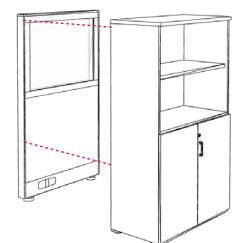

- It is obligatory that manufacturer's files of office furniture indicate the height, the width and the external depth of the file

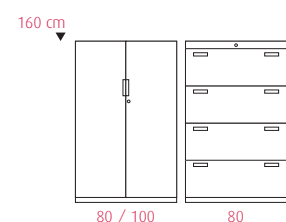

UNE EN ISO 14073-1

functional archive requirements

- The **cabinet will not produce any damage** unless a fully laden cabinet falls from a considerable height.
- The **edges** should be **rounded** and shouldn't possess a burr as the user will hurt themselves on them. Furthermore, tubes with extreme openness shouldn't exist.
- The **distance of security** of any mobile accessible part should be < 8 mm or > 25 mm, to avoid injury to the user.
- The previous directive applies to walls whose movement is one to the other, except doors, hinged covers and extension elements.
- The distances mentioned before also apply to distances between handles and other parts.
- The **ajustable parts** must be controlled so that they cannot be operated accidentally.
- **Extension elements** must be planned in effective retention systems.

European standard for consultation

- CEN/TR 14073-1:2004. Office furniture - Storage furniture - Part 1: Dimensions.
- EN 14073-2:2004. Office furniture - Storage furniture - Part 2: Safety requirements
- EN 14073-3:2004. Office furniture - Storage furniture - Part 3: Test methods for determination of stability and the strenght of structure



c_furniture

03 · storage

storage
use advices

Mobility and transportation

Movility
with pallets

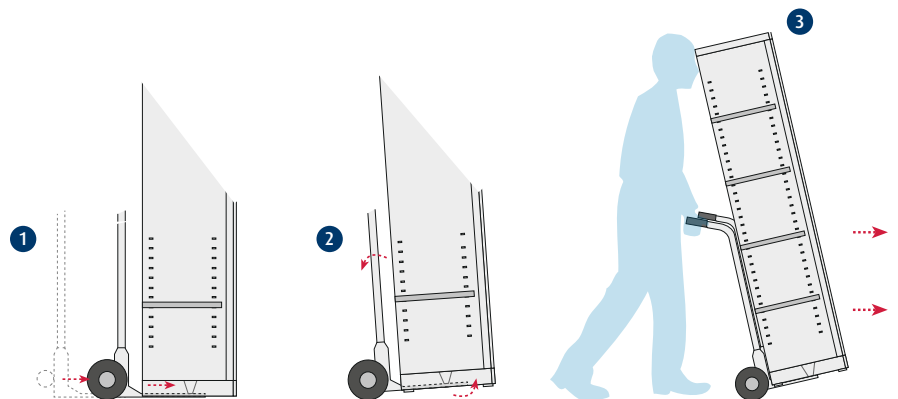

Movility
with wheels

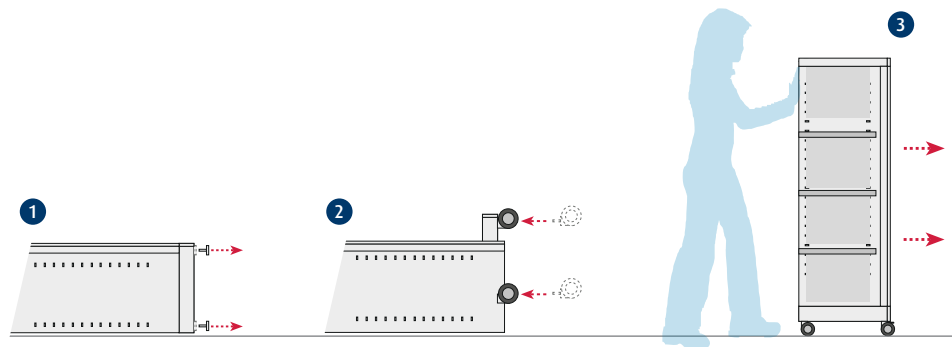

Loading process

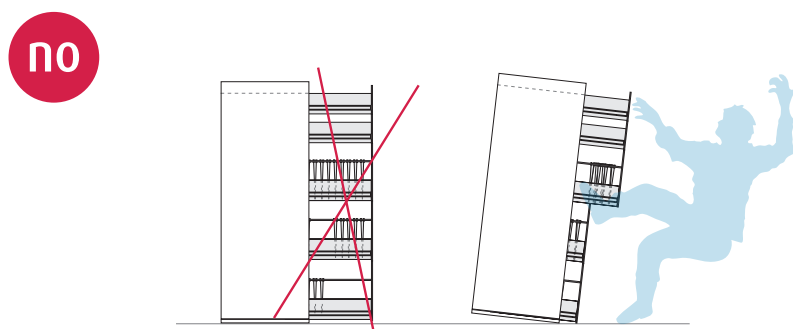
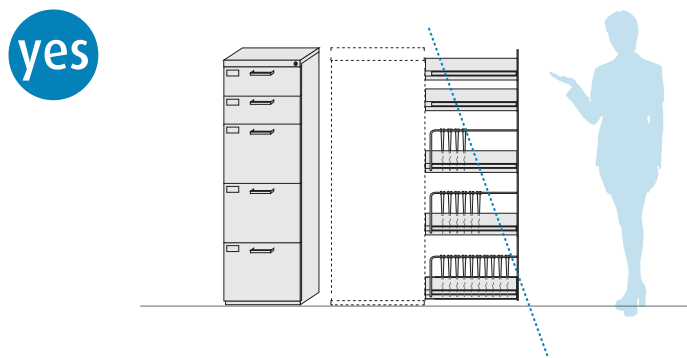

Loading advices

The loading of cabinets and filing systems (mobile and fixed) must be carried out from the lower part upwards to avoid the overturn of the furniture and cause dangerous accidents.

It is convenient to carry out the loads from the furthest areas to the most accessible areas, to avoid decompensation of the furniture and unwanted overturns.

The **TOTAL WEIGHT** is the weight of the cabinet or element plus the weight of its support. The weight content of the elements should be established in the following table, unless the manufacturer establishes a maximum load. (Indicated in a visible and durable way):

Load per unit area:	
Shelves	1,5 kg/dm ²
Bar slide racks	5,0 kg/dm ²
Extension elements	0,5 kg/dm ²
Hanging folder racks	4,0 kg/dm ²

04

screens

Screens and dividers are important furniture elements for the distribution of space and separation of posts.

According to its definition, a divider (screen) is a piece of furniture that divides spaces and is not fixed to the floor or ceiling, and may bear a character or not. The systems fixed to the floor and ceilings are excluded from the application site of rules area. (Screens, although the term is used the rules).

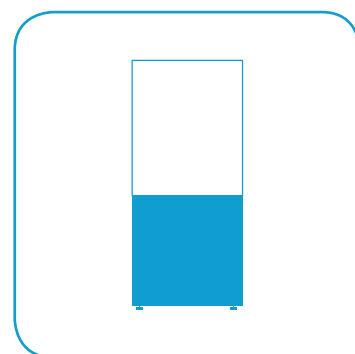

IT IS CALLED A PARTITION PANEL THAT CONSISTS OF A METAL STRUCTURE, NORMALLY IN A RECTANGULAR SHAPE AND A WOODEN OR OTHER PANEL, GENERALLY OPAQUE.

THE RULE HAS MODIFIED THIS OFFICE ELEMENT AS THE OFFICE SCREEN.

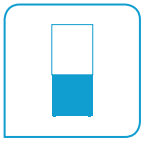

c_furniture

04 · screens

screens dimensions & requirements

Dimensions

The dimensions set out in this manual are collected with anthropometric data including 90% of the European population.

The dimensional data is reflected in the following table:

	Sitting Position	Standing Position	
Height	Maximum 110 cm	Maximum 140 cm	WITH visual contact
	Maximum 140 cm	Maximum 180 cm	WITHOUT visual contact
Width	It will be related to the width and depth of work surfaces and with cabinets, so that they are combinable and compatible with one another		<i>If you have to place an order consult your manufacturer or distributor as to which is the better option adapted for your place of work.</i>
Thickness	Although it is not standardized, it is recommended that you provide better product stability		

Standing position

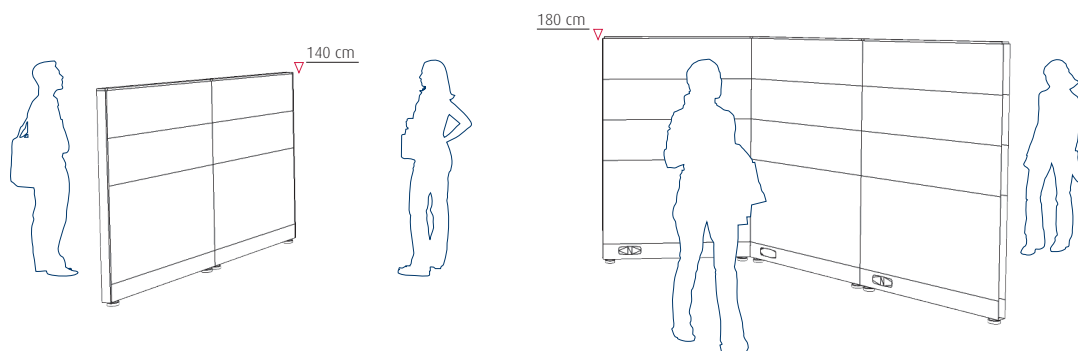

With Visual Contact

Without Visual Contact

Sitting position

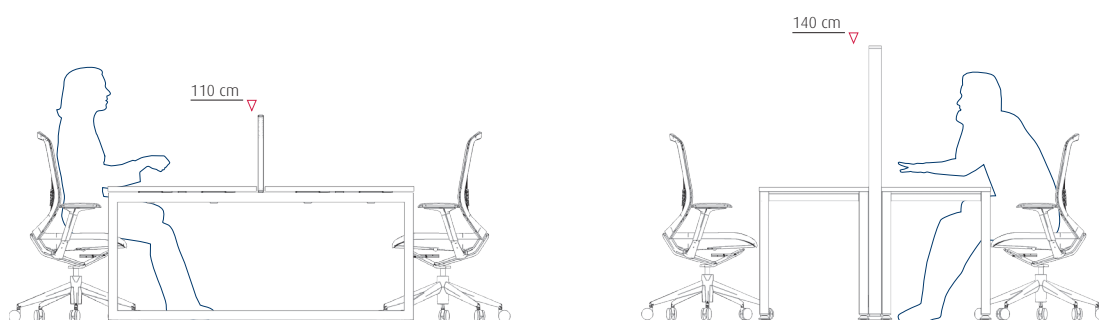

With Visual Contact

Without Visual Contact

European standard for consultation

- EN-1023-1:1996. Office furniture - Screens - Part 1: Dimensions.
- EN-1023-2:2000. Office furniture - Screens - Part 2: Mechanical safety requirements.
- EN-1023-3:2000. Office furniture - Screens - Part 3: Test methods

