



For safe and optimum performance, the WhisperPower Inverter-Charger must be used properly. Carefully read and follow all instructions and guidelines in this manual and give special attention to the CAUTION and WARNING statements.

PLEASE KEEP THIS MANUAL FOR FUTURE REFERENCE

Disclaimer

While every precaution has been taken to ensure the accuracy of the contents of this guide, **WhisperPower BV** assumes no responsibility for errors or omissions. Note as well that specifications and product functionality may change without notice.

Important

Please be sure to read and save the entire manual before using your **WP-BC Supreme Battery Charger**. Misuse may result in damage to the unit and/or cause harm or serious injury. Read manual in its entirety before using the unit and save manual for future reference.

Product Numbers:

61121040 WP-Supreme Combi 1000-40
61122055 WP-Supreme Combi 2000-55

Service Contact Information

Email: service@whisperpower.com
Phone : +31 (0) 512 571 555
Web : www.whisperpower.com

TABLE OF CONTENTS

1. Introduction
2. Product description
3. Installation
4. Unit operation
5. Troubleshooting
6. Specifications
7. Warranty

1000W-40A
2000W-55A

1. INTRODUCTION

Thank you for purchasing the WhisperPower Inverter-Charger. With our state of the art, easy to use design, this product will offer you reliable service by providing AC power and 5V USB power for your home, cabin, boat, RV or Trailer using battery power and recharge your battery automatically when utility AC is available. The Sinewave Inverter-Charger can run many AC-powered appliances when you need AC power anywhere. The 5V USB power can charge many USB-powered devices. The multi-stage battery charger will charge different type of batteries. This manual will explain how to use this unit safely and effectively. Please read and follow these instructions and precautions carefully.

Important safety information

This section contains important safety information for the Sinewave Inverter-Charger. Each time, before using the unit, READ ALL instructions and cautionary markings on or provided with the unit, and all appropriate sections of this guide. The Sinewave Inverter-Charger contains no user-serviceable parts. See Warranty section for how to handle product issues.

WARNING: Fire and/or Chemical Burn Hazard Do not cover or obstruct any air vent openings and/or install in a zero-clearance compartment. **WARNING:** Failure to follow these instructions can result in death or serious injury.



- When working with electrical equipment or lead acid batteries, have someone nearby in case of an emergency.
- Study and follow all the battery manufacturer's specific precautions when installing, using and servicing the battery connected to the inverter.
- Wear eye protection and gloves.
- Avoid touching your eyes while using this unit.
- Keep fresh water and soap on hand in the event battery acid comes in contact with eyes. If this occurs, cleanse right away with soap and water for a minimum of 15 minutes and seek medical attention.
- Batteries produce explosive gases. DO NOT smoke or have an open spark or fire near the system.
- Keep unit away from moist or damp areas.
- Avoid dropping any metal tool or object on the battery. Doing so could create a spark or short circuit which goes through the battery or another electrical tool that may create an explosion.

WARNING: Shock Hazard. Keep away from children! Avoid moisture. Never expose unit to snow, water etc. Unit provides 230 Vac, treat the AC output socket the same as regular wall AC sockets at home. **WARNING:** Explosion hazard! DO NOT use the unit in the vicinity of flammable fumes or gases (such as propane tanks or large engines). AVOID covering the ventilation openings. Always operate unit in an open area. Prolonged contact to high heat or freezing temperatures will decrease the working life of the unit.



CE EMC information

This equipment has been tested and found to comply with the limits for CE EMC standard. These limits are designed to provide reasonable protection against harmful interference in a residential installation. This equipment generate, uses and can radiate radio frequency energy and, if not installed and used in accordance with the instructions, may cause harmful interference to radio communications. However, there is no guarantee that interference will not occur in a particular installation. If this equipment does cause harmful interference to radio or television reception, which can be determined by turning the equipment off and on, the user is encouraged to try to correct the interference by one or more of the following measures:

- Reorient or relocate the receiving antenna.
- Increase the separation between the equipment and the receiver.
- Connect the equipment into an outlet on a circuit different from that to which the receiver is connected.
- Consult the dealer or an experienced radio/TV technician for help.

Limitations on use

Do not use in connection with life support systems or other medical equipment or devices.

2. PRODUCT DESCRIPTION

- The Sinewave Inverter-Charger includes the items list below.
- Inverter-Charger base unit (one of the following models)
 - 1000W Unit: Sinewave Inverter 1000W with 40A charger
 - 2000W Unit: Sinewave Inverter 2000W with 55A charger
- Owner's manual

3. INSTALLATION

WARNING: It is recommended that all wiring be done by a certified technician or electrician to ensure adherence to the applicable electrical safety wiring regulations and installation codes. Failure to follow these instructions can damage the unit and could also result in personal injury or loss of life. **CAUTION:** Before beginning unit installation, please consider the following: The unit should be used or stored in an indoor area away from direct sunlight, heat, moisture or conductive contaminants. When placing the unit, allow a minimum of three inches of space around the unit for optimal ventilation.



Understanding the unit features

AC Output Front Panel

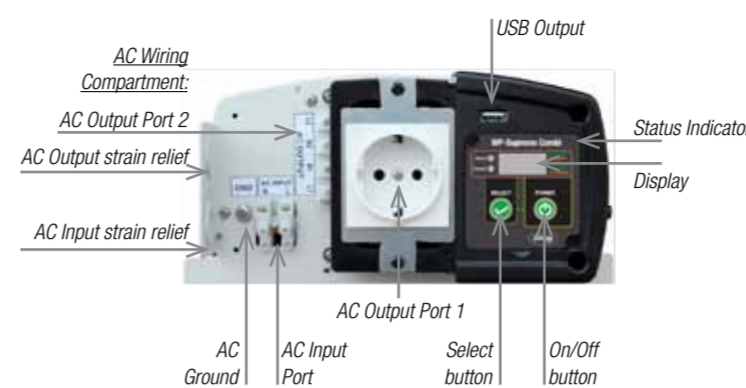

DC Input Rear Panel



Preparing for Installation

Typical Wiring block diagram of the Power Inverter:

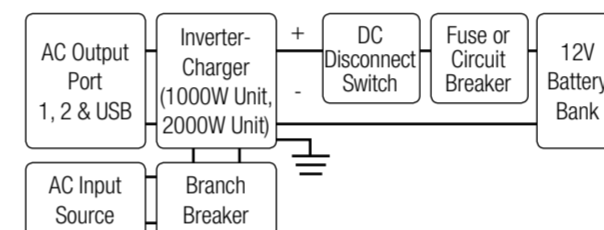

12V Battery Bank:

- The use of deep cycle battery is highly recommended for power inverter application
- For battery size, you need to identify what you wish to operate, and for how long. It is recommended that you purchase as much battery capacity as possible. See more on Battery Run time and Load in Section 4.

Fuse or Circuit Breaker:

- DC-rated fuse or DC-rated circuit breaker connected along the DC positive line is required.
- For 1000W Unit, select a fuse or circuit breaker with a minimum of 150 Adc
- For 2000W Unit, select a fuse or circuit breaker with a minimum of 300 Adc
- Based on the size of your 12V Battery Bank, determine the overall short circuit current rating of the battery bank from the battery manufacturer. The fuse or circuit breaker chosen has to be able to withstand the short circuit current that may be generated by the battery bank

Disconnect Switch:

- Select a DC Disconnect Switch with the same or higher rating of the selected fuse or circuit breaker.
- The DC Disconnect Switch is used to disconnect the DC power between the unit and the battery bank during service, maintenance or trouble shooting.

DC Input Cable Size:

- Use of low resistance wire is required for all the DC connections between the unit and the battery bank.
- For 1000W Unit, use minimum #2 AWG wire with maximum cable length of 5 feet.
- For 2000W Unit, use minimum #2/0 AWG wire with maximum cable length of 5 feet.

Grounding Cable Size:

Important: The unit is grounded through the ground stud of the unit located near the DC Input terminal and the chassis of the unit has to be grounded properly before use.

- For Marine application, the DC grounding cable size may be one size smaller than the minimum size conductor required for the DC current carrying conductors and the conductor is no smaller than #10AWG.
- For Recreational Vehicle application, the unit has to be grounded to the vehicle chassis with a minimum #8 AWG copper conductor.

AC Input Source and Branch Breaker:

- Standard AC Input wire is required for all the AC connections between the AC source & the AC Input port, and the AC Output ports to load.
 - A 16A branch circuit breaker is required to connect between AC Input source and unit's AC Input port.
- Important:** Follow the electrical and or building code when you connect the unit to any AC source.

Installing the Inverter-Charger System

WARNING: Electrical Shock Hazard

The unit 'On/Off' switch does not disconnect the DC power from the battery. Use the DC Disconnect Switch or disconnect the DC input cables connection to disconnect the DC power from the battery before working on any circuits connected to the unit. Failure to follow these instructions can result in death or serious injury.



Installation:

- Choose an appropriate mounting location.
- For indoor use, the unit can be mounted in any direction except with the DC Input panel facing downwards.
- Use the mounting template below to mark the positions of the mounting screws.
- Drill the 4 mounting holes and place the Inverter-Charger in position and fasten the unit to the mounting surface.

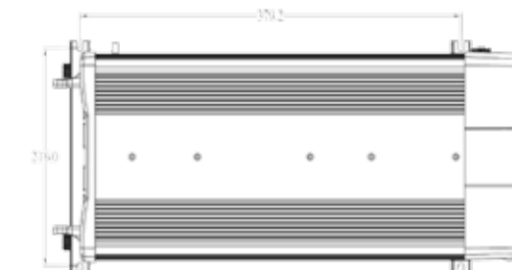

Chassis Grounding Connection:

DANGER: The unit chassis has to be grounded properly. Never operate the Inverter-Charger without proper grounding. Failure to do so will result in death or serious injury.



- Connect the grounding cable's ring terminal to the unit ground screw.
- Connect the other side of the cable to the common grounding point.

DC Input Connection:

CAUTION: Reversing the DC Input terminal will damage the unit and it cannot be repaired. Damage caused by reverse polarity connection is not covered by the warranty.



- Connect one end of the negative DC input cable to the Inverter-Charger DC negative terminal. Connect the other end of the negative DC input cable to the battery negative terminal.
- Make sure the Disconnect Switch is in the OFF position.
- Connect one end of the positive DC input cable to the Power Inverter DC positive terminal. Connect the other end of the positive DC input cable to one of the terminals of the Disconnect Switch.
- Connect a DC input cable between the other terminal of the Disconnect Switch and one side of the terminal of the fuse holder.

- Connect a DC input cable between the other terminal of the fuse holder and the battery positive terminal.
- Install the selected fuse to the fuse holder.
- Turn Disconnect Switch to ON position.

AC Input Connections:

Warning: Please double check on the location of the AC input port located inside the wiring compartment. Misconnecting to the AC output port inside the same compartment will blow the unit and may catch fire.



Before making any AC Input and output connection, please be sure the AC Input Source is not energized and the DC disconnect switch is OFF.

Important: A 16A branch breaker (not provided) is required to connect between the AC source and the Inverter-Charger.

- Remove AC compartment cover by unscrewing the two screws located at the front of the AC compartment cover.
- Connect the AC Input 'H' wire between the unit's AC Input port and the branch breaker terminal.
- Connect the AC Input 'N' wire between the unit's AC Input port and the AC source 'N' terminal.

AC Output Connections:

CAUTION: Please be sure that the AC Input source is not energized before making any AC Input and Output connection and that the DC disconnect switch is turned OFF.



The AC Output connection has three types of configurations: Use of the provided AC socket (Port 1) for AC load:

- This configuration does not require AC Output installation. Plug in the AC load to the provided AC output socket. During the by-pass mode, the AC output is limited to 16A.
- Use of the provided Hardwire AC Output terminal (Port 2).
- Remove AC compartment cover located on the front panel of the unit.
- Hardwire the AC load or any external AC socket to the AC Output port 2. Please verify the 'H' and 'N' connection on the AC Output port.

Note: During Battery Power Mode, all AC output is limited to 4.3A for 1000W model or 8.7A for 2000W model.

Remote Display Connection:

- The Remote Display on the unit is detachable. To install the remote to different location, an optional 6 pin standard RJ12 cable (not provided) is required.
- Remove the 2 screws at the front of the Display Panel and remove the small RJ12 cable.
- Install the optional RJ12 standard cable to your desired location. Please note polarity.
- Connect one end of the RJ12 cable to the unit and the other end of the cable to the Display Panel. Please note polarity.

Test the Inverter-Charger connection:

- Switch DC disconnect switch to ON.
- Switch the AC Branch circuit breaker to ON.
- The LED on display will turn on. If AC input source is available, 'Status' LED turns green. This indicates the unit is running in by-pass mode meaning AC output is running from the AC input source.
- Disconnecting the AC input source by turning OFF the 16A branch breaker will change the 'Status' LED on the Display to amber.
- Both AC output and 5V USB are now available.
- Plug in a small AC load like a 40W table lamp or small appliance to the AC socket to verify AC is available.
- The unit is successfully installed and functioning properly.



4. UNIT OPERATION

Auto Backup Mode (Factory default setting-“Fd”):

The unit is fully automatic. When utility power is available, the unit is running in AC bypass mode. AC output is supplied from the utility. The internal AC charger is ON and will automatically top up the battery bank that is connected to the unit. When there is a power failure from the utility or an AC source is not available, the unit will run on battery power and the unit will generate sinewave AC output to maintain and operate the load continuously.

Non-Backup Mode

Same as Auto Backup Mode but when there is a power failure of the utility or the AC input source is not available, the inverter will not turn ON automatically. You are required to manually turn ON the inverter using the ‘Power’ button.

Understanding the Display Function:



Status LED	Display LED	Display	Function/Status
Green (solid)	Green	‘FUL’	By-Pass Mode. Battery is fully charged
Green (flashing)	OFF	‘bul’	By-Pass Mode. Battery charging in progress and is in ‘BULK’ mode
	OFF	‘Abs’	By-Pass Mode. Battery charging in progress and is in ‘ABSORPTION’ mode
Amber (solid)	Green	‘12.5’	Battery Mode, inverter is running, display shows battery voltage in DC volts
	Amber	‘0.80’	Battery Mode, inverter is running, display shows output power in kW (800W as shown)
Amber (flashing)			Battery Mode and AC Input is detected and AC output will switch to By-Pass mode within 20 seconds
Red (solid)	OFF	E01-E12	Unit has shutdown. Display shows error code (See error code reference chart below)

Understanding the Power and Select push button function

A beep sound will occur every time when the ‘Power’ or ‘Select’ button is trigger.

‘Power’ button function:

- Turns inverter On/Off during Battery Power Mode. Press and hold for 1 second to turn unit ON or OFF

Note: The ‘Power’ button cannot be used to turn AC Output OFF during AC By-Pass mode.

‘Select’ button function:

- Check unit setting: Press once to check or verify unit’s present set functions

Understanding the Error Code

Code	Condition	Corrective Action
E01	Input battery voltage is too low and unit has shutdown	Recharge battery immediately and restart unit
E02	Input battery voltage is too high and unit has shutdown	Check battery voltage or determine if any external charger is connected to the battery bank
E03	AC output is overloaded or short circuited and unit has shutdown	Check load connected to the output. Reduce load and restart the unit
E04	Internal temperature is too high and unit has shutdown	Turn unit off and wait for 15 minutes before restarting. Check if any object has blocked the air flow of the unit
E05	Input battery voltage is low and warning occurs	Recharge battery as unit will shutdown shortly
E06	AC output has sensed high and is close to shutdown limit	Reduce load
E07	Internal temperature is high and is close to shutdown limit	Reduce load and check if any ventilation of the unit is blocked
E08	Not used	
E09	Not used	
E10	Battery Charging voltage too high	Check battery setting
E11	Battery bad	Battery did not accept charge
E12	Internal transfer switch temperature is high and shutdown occurs	Reduce load and check if any ventilation of the unit is blocked



AC Load on Inverter

Although the Power Inverter can provide high surge power up to two times the rated output power, some high surge loads like sump-pumps, heavy duty motors etc. may still trigger the inverter protection system even though the load falls within the power rating of the inverter. A higher power Inverter-Charger is required for these appliances.

Estimate Run time on Load

Following run times are estimates for reference, based on using different battery bank sizes. Actual run times may vary.

AC Load	Estimate run time on different 12V Battery Bank Size				
	60AH	120AH	180AH	240AH	300AH
50W	11 hrs.	22 hrs.	33 hrs.	44 hrs.	55 hrs.
100W	5 hrs.	11.5 hrs.	17 hrs.	23 hrs.	29 hrs.
200W	2.5 hrs.	5 hrs.	8 hrs.	11 hrs.	13.5 hrs.
500W	49 mins	2 hrs.	3 hrs.	4 hrs.	5 hrs.
1000W	15 mins	49 mins	1.5 hrs.	2 hrs.	2.5 hrs.
1500W	8 mins	27 mins	49 mins	1 hr	1.5 hrs
2000W	N.R.	15 mins	34 mins	49 mins	1 hrs
2500W	N.R.	11 mins	25 mins	37 mins	49 mins
3000W	N.R.	N.R.	17 mins	27 mins	37 mins

Note: N.R. - Not Recommended

5. FEATURE SETTING

To understand more about the unit features, read the following section and follow the instructions to make changes to the desired setting.

Default Factory Setting:

- In (Inverter): In1 - inverter enabled in standby mode with load sense off
Cu (Charger): 40A or 55A - charger enabled (40A for 1000W Unit and 55A for 2000W Unit)
- AL (Alarm): AL1 - alarm enabled
Sd (UV shutdown): SdL - Under voltage shutdown set to low setting
bAt (Battery type): FLo - Flooded typed
Cb (Maximum current): Cb3 - Maximum Shore Power Current draw is 16A

Understanding the Unit Settings

Inverter Setting	
In0	Inverter is disabled, unit will not provide backup function when utility power is not available
In1	Inverter is set to standby mode with power save mode OFF. Unit will provide backup function when utility power is not available
In2	Inverter is set to standby mode with power save mode ON. Unit will provide backup function only when utility power is not available AND the load connected to the output is >10W and once it is ON, it will turn off when the output is <3W. Note: Unit will turn ON every 10 s to check on the power consumption.
Charger Current Setting	
5A-40A 5A-55A	Bulk/Float current setting: 1000W Unit: 5A/1.5A, 10A/2A, 20A/3A, 40A/4A 2000W Unit: 5A/1.5A, 15A/3A, 35A/4A, 55A/6A
Battery Type and Voltage Setting (Bulk/Absorption/Float)	
FLo	Flooded: 14.4V / 14.4V / 13.5V
GEL	GEL: 14.2V / 14.2V / 13.8V
AG	AGM: 14.3V / 14.3V / 13.4V
FI	Fixed: 13.5 Vdc fixed voltage
Battery Under Voltage Setting	
SdL	Battery under voltage setting is set to LOW (setting used for normal operation) Under voltage alarm: 11.0 Vdc Under voltage alarm recovery: 11.3 Vdc Under voltage shutdown: 10.5 Vdc Under voltage recovery: 12.0 Vdc
SdH	Battery under voltage setting is set to HIGH (setting to avoid battery over discharge when connected to car start battery) Under voltage alarm: 12.1 Vdc Under voltage alarm recovery: 12.3 Vdc Under voltage shutdown: 11.8 Vdc Under voltage recovery: 12.6 Vdc
Alarm Setting	
AL0	Fault and warning audible alarm is disabled. Display panel only shows error code and audible alarm will not sound.
AL1	Audible alarm will sound when fault or warning occurs.
AC Input Branch Breaker Setting	
	1000W Unit 2000W Unit
	AC Load current Charger Current AC Load Current Charger Current
Cb1	Setting for AC Input Breaker with 8A rating. Maximum current draw from AC Input Breaker = 8A. Battery charger charging current will automatically reduce when there is a high power draw from AC input. > 9 Aac 5 Adc > 6.5 Aac 5 Adc 6-7 Aac 10 Adc 4.5-6.5 Aac 15 Adc 4-6 Aac 20 Adc 2.5-4.5 Aac 35 Adc < 4 Aac 40 Adc < 2.5 Aac 55 Adc
Cb2	Setting for AC Input Breaker with 10A rating. Maximum current draw from AC input Breaker = 10A. > 9 Aac 5 Adc > 8.5 Aac 5 Adc 8-9 Aac 10 Adc 6.5-8.5 Aac 15 Adc 6-8 Aac 20 Adc 4.5-6.5 Aac 35 Adc < 6 Aac 40 Adc < 4.5 Aac 55 Adc
Cb3	Setting for AC Input Breaker with 16A rating. Maximum current draw from AC input Breaker = 16A > 15 Aac 5 Adc > 14.5 Aac 5 Adc 14-15 Aac 10 Adc 12.5-14.5 Aac 15 Adc 12-14 Aac 20 Adc 10.5-12.5 Aac 35 Adc < 12 Aac 40 Adc < 10.5 Aac 55 Adc
Manufacturing Default Setting	
Fd	Reset all settings to manufacturing default settings (40A for 1000W Unit or 55A for 2000W Unit, In1, AL1, SdL, Flo, Cb3)

Understanding the Charger De-rating Current:

The charger current will be de-rated when the environment temperature reaches 60 °C (140 °F) or the internal temperature reaches the pre-set values.

Unit	De-rated Values	
Internal Temperature	>90°C (194°F)	Maximum charger will de-rated to half
	>95°C (203°F)	Charger current reduced to 5A
Environment Temperature	<85°C (185°F)	Charger current recover back to set value
	>60°C (140°F)	Charger current reduced to 5A
	>55°C (131°F)	Charger current recover back to set value

Enter Function Menu for unit setting:

To enter unit Function Menu, press and hold “Power” and “Select” button together for about 5 seconds until a beep is sounded.

When you are in Function Menu:

- Press ‘Power’ button for 1 second to toggle between different Functions Menu like ‘Cu’, ‘In’, ‘AL’, ‘Sd’, ‘bAt’, ‘Cb’ and ‘Fd’ etc.
- Press ‘Select’ button for 1 second to enter Individual Function Set Menu and you can make change to the settings.
- The unit will EXIT the Main Menu automatically if ‘Power’ and ‘Select’ buttons is not trigger for more than 5 seconds.

When you are in Individual Function Set Menu:

- Press ‘Select’ button for 1 second to toggle between different setting values.
- Press ‘Select’ button for 5 seconds to set selected setting and exit to next Main Menu

See more details on flow chart below.

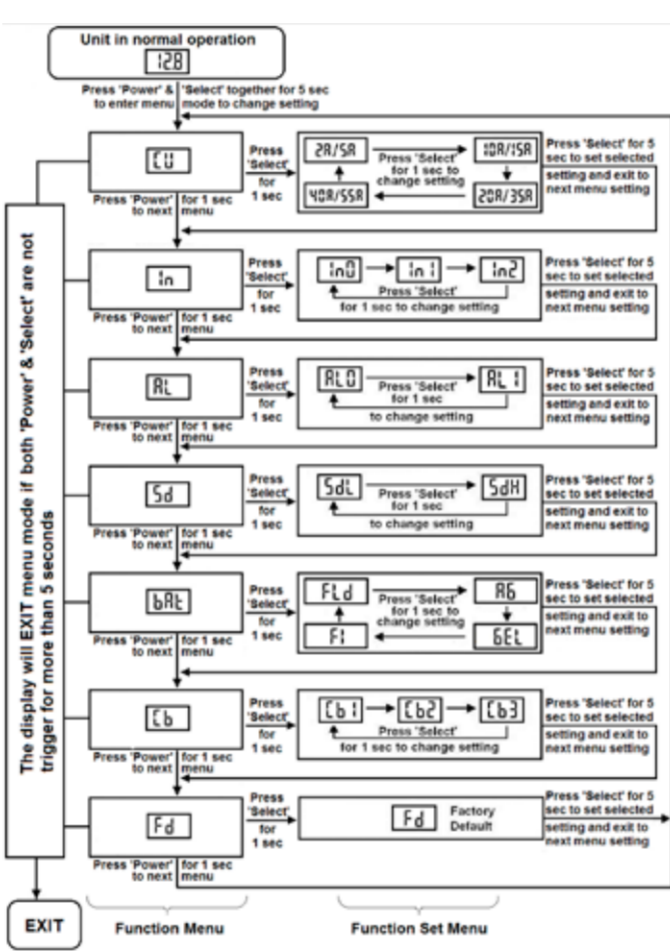

6. TROUBLESHOOTING

To troubleshoot the unit, please note the error code displayed on the main unit and review “Understanding the Error Codes” in section 4.

Problem	Symptom	Solution
No output voltage. And Status LED is off.	The unit is off	Turn unit ON by following the instruction in Section 4 to turn unit ON
	No power to unit	Check DC fuse, Disconnect switch (if installed) and check if Branch breaker is either blown or turned OFF
No AC output. Status LED is Green	Circuit Breaker is tripped	Check load and reset the breaker
	Circuit Breaker is tripped Check error code on display	Check load and reset the breaker Verify the error condition and make correction
No Output. Status LED is in Amber	Check AC Load Sense setting	AC Load connected must be below the threshold of the AC Load sense setting

7. SPECIFICATIONS

Note: Specifications are subject to change without notices.

Article nr.	WP-SUPREME COMBI 1000-40	WP-SUPREME COMBI 2000-55
		61121040
INVERTER		
AC Output Power	1000W	2000W
AC Output Current	4.3A	8.7A
AC Surge Power (Peak)	2000W	4000W
AC Output Voltage/Frequency	230VAC / 50Hz	
AC Output Waveform	Sinewave (<3% THD)	
Nominal DC input Voltage	12.5VDC	
No Load battery draw	< 1.5ADC	
DC Input Voltage operating range	10.5 – 15.5VDC	
Under Voltage Alarm	11.0/12.1VDC	
Under Voltage Alarm Recovery	11.3/12.3VDC	
Under Voltage Shutdown	10.5/11.8VDC	
Under Voltage Recovery	12.0/12.6VDC	
Over Voltage Shutdown	15.5VDC	
USB		
USB Port	5V, 750mA	
AC TRANSFER SWITCH		
Transfer Time	< 30ms	
Transfer Relay Rating	16A	
AC Input Source Setting	8, 10, 16A	
AC Output Port 1 (AC Socket) CB1-3	16A max	
AC Output Port 2 (Hard Wire Connector)	16A max	
DISPLAY		
Display Panel Port	RJ12	
Inverter Mode	Input Voltage, Output Power	
Charger Mode	Status & Battery voltage	
CHARGER		
Charging Voltage Range	13.5 -14.4VDC	
Float Voltage Range	13.4 – 13.8VDC	
Charger Current (max)	40ADC	55ADC
Charger Current Setting	5,10,20,40	5,15,35,55
Battery Type	Gel, Flooded, AGM, Fixed	
Charge Control	Bulk/Absorption/Flooded	
Efficiency	>80%	
SAFETY AND ENVIRONMENTAL		
Agency Markings	CE	
Operating Temperature	0°C to 40°C (32°F to 104°F)	
Storage Temperature	-20°C to 60°C (-4°F to 140°F)	
Relative Humidity	5-90% noncondensing	
Operating Altitude	Up to 9,843ft (3000m) above sea level	
WEIGHTS AND DIMENSIONS		
Weights	12.5lbs (5.7kg)	14.5lbs (6.6kg)
Dimensions	9.0 x 18.8 x 4.5” (230 x 478 x 114 mm)	

8. WARRANTY

One Year Limited Warranty

The limited warranty program is the only one that applies to this unit, and it sets forth all the responsibilities of WhisperPower Technology. There is no other warranty, other than those described herein. Any implied warranty of merchantability of fitness for a particular purpose on this unit is limited in duration to the duration of this warranty.

This unit is warranted, to the original purchaser only, to be free of defects in materials and workmanship for one year from the date of purchase without additional charge. The warranty does not extend to subsequent purchasers or users.

Manufacturer will not be responsible for any amount of damage in excess of the retail purchase price of the unit under any circumstances. Incidental and consequential damages are specifically excluded from coverage under this warranty.

This unit is not intended for commercial use. This warranty does not apply to damage to units from misuse or incorrect installation/connection. Misuse includes wiring or connecting to improper polarity power sources.

Return/repair policy:

If you are experiencing any problems with your unit, please contact our customer service department at sales@whisperpower.com or (0031)512 571 550 before returning product to retail store. After speaking to a customer service representative, if products are deemed non-working or malfunctioning, the product may be returned to the purchasing store within 30 days of original purchase. Any defective unit that is returned to manufacturer within 30 days of the date of purchase will be replaced free of charge.

If such a unit is returned more than 30 days but less than one year from the purchase date, manufacturer will repair the unit or, at its option, replace it, free of charge. If the unit is repaired, new or reconditioned replacement parts may be used, at manufacturer’s option. A unit may be replaced with a new or reconditioned unit of the same or comparable design. The repaired or replaced unit will then be warranted under these terms for the remainder of the warranty period. The customer is responsible for the shipping charges on all returned items.

Limitations:

This warranty does not cover accessories, such as adapters and batteries, damage or defects result from normal wear and tear (including chips, scratches, abrasions, discoloration or fading due to usage or exposure to sunlight), accidents, damage during shipping to our service facility, alterations, unauthorized use or repair, neglect, misuse, abuse, failure to follow instructions for care and maintenance, fire and flood. If your problem is not covered by this warranty, call our Customer Service Department at sales@whisperpower.com or (0031)512 571 550 for general information if applicable.

EC DECLARATION OF CONFORMITY

We Whisper Power BV, Kelvinlaan 82, 9207 JB Drachten, The Netherlands, hereby declare that:

Product:

61121040 WP-Supreme Combi 1000-40
61122055 WP-Supreme Combi 2000-55

Is in conformity with the following provisions of the EC

2004/108/EC (EMC directive). The following

harmonized standards have been applied:

- Generic emission standard: EN61000-6-3: 2007
- Generic immunity standard: EN61000-6-1: 2007

2006/95/EC (Safety directive),

with the following standard:

- Low voltage standard: EN60950: 2000

Drachten,

R. ter Heide
C.E.O. Whisper Power B.V.