

Nokia 6110

User's Guide

DECLARATION OF CONFORMITY

Hereby, NOKIA CORPORATION declares that this RM-122 product is in compliance with the essential requirements and other relevant provisions of Directive 1999/5/EC. A copy of the Declaration of Conformity can be found at http://www.nokia.com/phones/declaration_of_conformity/

CE 0434

© 2008 Nokia. All rights reserved.

Nokia, Nokia Connecting People, Nokia Care, Navi, and Visual Radio are trademarks or registered trademarks of Nokia Corporation. Nokia tune and Visual Radio are sound marks of Nokia Corporation. Other product and company names mentioned herein may be trademarks or tradenames of their respective owners.

Reproduction, transfer, distribution, or storage of part or all of the contents in this document in any form without the prior written permission of Nokia is prohibited.

symbian This product includes software licensed from Symbian Software Ltd © 1998-2008. Symbian and Symbian OS are trademarks of Symbian Ltd.

US Patent No 5818437 and other pending patents. T9 text input software Copyright © 1997-2008. Tegic Communications, Inc. All rights reserved.



Java™ and all Java-based marks are trademarks or registered trademarks of Sun Microsystems, Inc.

This product is licensed under the MPEG-4 Visual Patent Portfolio License (i) for personal and noncommercial use in connection with information which has been encoded in compliance with the MPEG-4 Visual Standard by a consumer engaged in a personal and noncommercial activity and (ii) for use in connection with MPEG-4 video provided by a licensed video provider. No license is granted or shall be implied for any other use. Additional information, including that related to

promotional, internal, and commercial uses, may be obtained from MPEG LA, LLC. See <<http://www.mpegla.com>>.

Nokia operates a policy of ongoing development. Nokia reserves the right to make changes and improvements to any of the products described in this document without prior notice.

TO THE MAXIMUM EXTENT PERMITTED BY APPLICABLE LAW, UNDER NO CIRCUMSTANCES SHALL NOKIA OR ANY OF ITS LICENSORS BE RESPONSIBLE FOR ANY LOSS OF DATA OR INCOME OR ANY SPECIAL, INCIDENTAL, CONSEQUENTIAL OR INDIRECT DAMAGES HOWSOEVER CAUSED.

THE CONTENTS OF THIS DOCUMENT ARE PROVIDED "AS IS". EXCEPT AS REQUIRED BY APPLICABLE LAW, NO WARRANTIES OF ANY KIND, EITHER EXPRESS OR IMPLIED, INCLUDING, BUT NOT LIMITED TO, THE IMPLIED WARRANTIES OF MERCHANTABILITY AND FITNESS FOR A PARTICULAR PURPOSE, ARE MADE IN RELATION TO THE ACCURACY, RELIABILITY OR CONTENTS OF THIS DOCUMENT. NOKIA RESERVES THE RIGHT TO REVISE THIS DOCUMENT OR WITHDRAW IT AT ANY TIME WITHOUT PRIOR NOTICE.

The availability of particular products and applications and services for these products may vary by region. Please check with your Nokia dealer for details, and availability of language options.

Export controls

This device may contain commodities, technology or software subject to export laws and regulations from the US and other countries. Diversion contrary to law is prohibited.

NO WARRANTY

The third-party applications provided with your device may have been created and may be owned by persons or entities not affiliated with or related to Nokia. Nokia does not own the copyrights or intellectual property rights to the third-party applications. As such, Nokia does not take any responsibility for end-user support, functionality of the applications, or the information in the applications or these materials. Nokia does not provide any warranty for the third-party applications.

BY USING THE APPLICATIONS YOU ACKNOWLEDGE THAT THE APPLICATIONS ARE PROVIDED AS IS WITHOUT WARRANTY OF ANY KIND, EXPRESS OR IMPLIED, TO THE MAXIMUM EXTENT PERMITTED BY APPLICABLE LAW. YOU FURTHER ACKNOWLEDGE THAT NEITHER NOKIA NOR ITS AFFILIATES MAKE ANY

REPRESENTATIONS OR WARRANTIES, EXPRESS OR IMPLIED, INCLUDING BUT NOT LIMITED TO WARRANTIES OF TITLE, MERCHANTABILITY OR FITNESS FOR A PARTICULAR PURPOSE, OR THAT THE APPLICATIONS WILL NOT INFRINGE ANY THIRD-PARTY PATENTS, COPYRIGHTS, TRADEMARKS, OR OTHER RIGHTS.

Contents

SAFETY	9	Indicators.....	19
About your device	9	Menu.....	20
Network services	10	Welcome application	21
Battery removing.....	11	Volume control	21
Support	12	Keypad lock (keyguard)	21
Help application.....	12	Access codes.....	21
Issues with your device.....	12	Lock code.....	21
Reset the device	12	PIN codes.....	22
Restore original factory settings.....	12	PUK codes.....	22
Update your device software.....	12	Barring password	22
Get started	14	My own key	22
Insert a SIM or USIM card and battery.....	14	Attach a wrist strap.....	23
microSD card	15	Connect a compatible headset.....	23
Charge the battery	16	Connect a USB data cable.....	23
Switch the device on or off.....	16	Call functions	24
Set time and date.....	16	Make a call.....	24
Normal operating position.....	16	Speed dialing.....	24
Configuration settings.....	17	Voice dialing.....	24
Your phone	18	Make a conference call (network service)	25
Keys and parts.....	18	Answer or reject a call.....	25
Standby mode.....	18	Answer a video call	26
Active standby.....	19	Call waiting (network service).....	26
		Options during a call.....	26
		Make a video call	27

Video sharing.....	28
Video sharing requirements	28
Share video.....	28
Accept an invitation	29
Log.....	29
Recent calls.....	29
General log.....	30
Navigator	31
Navigator application.....	32
Navigator key	32
Keypad shortcuts in the Navigator application....	33
Navigate to locations.....	33
Navigate to a destination	33
Alarms.....	34
Set road blocks.....	34
Browse the map.....	34
View location information.....	34
Send and save location information	34
Plan trips.....	35
Settings	35
Extras	35
Transfer maps from PC.....	36
Write text	37
Traditional text input.....	37
Predictive text input.....	37
Write compound words.....	38
Copy and delete text	38

Messaging.....	39
Write and send messages	39
Nokia Xpress audio messaging.....	40
E-mail settings.....	41
Inbox—receive messages.....	41
View multimedia objects	41
Special message types.....	41
Service messages.....	41
My folders	41
Mailbox	42
Retrieve e-mail messages from the mailbox.....	42
Delete e-mail messages	42
Outbox.....	43
Cell broadcast	43
Service command editor	43
Messaging settings.....	43
Text message settings.....	43
Multimedia messaging settings.....	44
E-mail settings.....	45
Service message settings.....	46
Cell broadcast settings.....	46
Other settings	46
Message reader.....	47
Contacts.....	48
Manage contacts.....	48
Manage contact groups	48
Add a ringing tone.....	48

Assign speed dialing keys.....	49	Add bookmarks manually	60
Gallery.....	50	Send bookmarks	61
Edit images.....	50	Connection security.....	61
Edit video clips.....	51	Browse web pages.....	61
Modify video.....	51	Keys and commands for browsing	61
Transfer videos from PC.....	52	Mini map	62
Download files.....	52	Page overview	62
Media	53	Web feeds and blogs.....	62
Camera	53	Saved pages.....	62
Camera settings.....	54	End a connection	63
Music player.....	54	Empty the cache.....	63
Music library.....	54	Browser settings.....	63
Listen to music.....	55	Download!.....	65
RealPlayer.....	56	Organizer	66
Play media files.....	56	Clock	66
Radio	56	Clock settings.....	66
Tune and save a radio station.....	57	Set an alarm	66
Radio functions.....	57	Turn off the alarm.....	66
Station list.....	57	World clock.....	66
View visual content	58	Calendar.....	66
Visual Radio settings.....	58	Create calendar entries	66
Station directory.....	58	Calendar views.....	67
Web	60	To-do	67
Set up the phone for the browser service	60	Notes	67
Make a connection	60	Converter.....	67
View bookmarks.....	60	Convert units.....	68
		Set a base currency and exchange rates.....	68

Applications.....	69	Instant messaging.....	84
GPS data.....	69	Connect to an IM server	84
Landmarks.....	70	IM settings.....	84
Adobe Reader.....	70	Join and leave an IM group.....	85
Open a .pdf file.....	70	Search for IM groups and users.....	85
View a document.....	70	Chat in an IM group.....	85
Settings	70	Start and view individual conversations.....	86
Quickoffice	71	IM contacts.....	86
Quickword	71	Create a new IM group.....	86
Quicksheet.....	71	Connectivity.....	87
Quickpoint.....	72	PC Suite.....	87
Quickmanager	72	Bluetooth connection	87
More information	72	Bluetooth connection settings.....	87
Settings.....	73	Send data	88
Profiles.....	73	Paired devices view	88
Themes.....	74	Receive data	89
3-D tones.....	74	Disconnect Bluetooth connection.....	89
Voice commands.....	74	USB data cable.....	89
Phone settings.....	75	Remote synchronization	89
General	75	Create a new synchronization profile.....	89
Phone.....	79	Synchronize data.....	90
Connection	81	Connection manager.....	90
Applications	83	View connection details.....	90
Speed dial	83	End connections.....	90
Speech	84	Push to talk.....	91
Settings wizard	84	Define a PTT access point	91
Call mailbox.....	84	Settings for PTT.....	91

Log in to PTT	92
Exit PTT	92
Make a one-to-one call.....	92
Answer a PTT call.....	92
Make a PTT group call.....	93
Callback requests	93
Channels	93
PTT sessions.....	94
Data transfer.....	94
Data manager	95
Application manager	95
Install an application	95
Remove an application.....	96
Application manager settings.....	96
File manager	96
View memory consumption.....	96
Device manager	97
Update software	97
Memory card.....	98
Format memory card	98
Backup and restore information.....	98
Lock and unlock the memory card	98
Activation keys.....	98
Battery and charger information	100
Charging and discharging.....	100
Nokia battery authentication guidelines.....	101

Nokia original enhancements	103
BATTERY	103
Nokia Multimedia Car Kit (CK-20W).....	104
Nokia Holder Easy Mount (HH-12).....	104
Mobile Holder (CR-48).....	104
Care and maintenance	105
Additional safety information	106
Small children	106
Operating environment	106
Medical devices	106
Implanted medical devices.....	106
Hearing aids.....	107
Vehicles.....	107
Potentially explosive environments.....	107
Emergency calls.....	108
To make an emergency call:	108
Certification information (SAR).....	109
Index	110

SAFETY

Read these simple guidelines. Not following them may be dangerous or illegal. Read the complete user guide for further information.



SWITCH ON SAFELY Do not switch the device on when wireless phone use is prohibited or when it may cause interference or danger.



ROAD SAFETY COMES FIRST Obey all local laws. Always keep your hands free to operate the vehicle while driving. Your first consideration while driving should be road safety.



INTERFERENCE All wireless devices may be susceptible to interference, which could affect performance.



SWITCH OFF IN RESTRICTED AREAS Follow any restrictions. Switch the device off in aircraft, near medical equipment, fuel, chemicals, or blasting areas.



QUALIFIED SERVICE Only qualified personnel may install or repair this product.



ENHANCEMENTS AND BATTERIES Use only approved enhancements and batteries. Do not connect incompatible products.



WATER-RESISTANCE Your device is not water-resistant. Keep it dry.

About your device

The wireless device described in this guide is approved for use on the GSM 850, 900, 1800, and 1900 and UMTS 2100 networks. Contact your service provider for more information about networks.

When using the features in this device, obey all laws and respect local customs, privacy and legitimate rights of others, including copyrights.

Copyright protection may prevent some images, music, and other content from being copied, modified, or transferred.

Your device supports several methods of connectivity. Like computers, your device may be exposed to viruses and other harmful content. Exercise caution with messages, connectivity requests, browsing, and downloads. Only

install and use services and other software from trustworthy sources that offer adequate security and protection against harmful software, such as applications that are Symbian Signed or have passed the Java Verified™ testing. Consider installing antivirus and other security software on your device and any connected computer.

Your device may have preinstalled bookmarks and links for third-party internet sites. You may also access other third-party sites through your device. Third-party sites are not affiliated with Nokia, and Nokia does not endorse or assume liability for them. If you choose to access such sites, you should take precautions for security or content.

Keep your device away from magnets or magnetic fields as they may cause some applications to activate unexpectedly.



Warning: To use any features in this device, other than the alarm clock, the device must be switched on. Do not switch the device on when wireless device use may cause interference or danger.

The office applications support common features of Microsoft Word, PowerPoint, and Excel (Microsoft Office 2000, XP, and 2003). Not all file formats can be viewed or modified.

Remember to make back-up copies or keep a written record of all important information stored in your device.

When connecting to any other device, read its user guide for detailed safety instructions. Do not connect incompatible products.

Network services

To use the phone you must have service from a wireless service provider. Many of the features require special network features. These features are not available on all networks; other networks may require that you make specific arrangements with your service provider before you can use the network services. Your service provider can give you instructions and explain what charges will apply. Some networks may have limitations that affect how you can use network services. For instance, some networks may not support all language-dependent characters and services.

Your service provider may have requested that certain features be disabled or not activated in your device. If so, these features will not appear on your device menu. Your device may also have a special configuration such as changes in menu names, menu order, and icons. Contact your service provider for more information.

This device supports WAP 2.0 protocols (HTTP and SSL) that run on TCP/IP protocols. Some features of this device, such as web browsing, e-mail, push to talk, instant messaging,

and multimedia messaging, require network support for these technologies.

Battery removing

Always switch the device off and disconnect the charger before removing the battery.

Support

Help application



Your device has context-sensitive help. You can access the help from an application or from the main menu.

To access help when an application is open, select **Options** > **Help**. To switch between help and the application that is open in the background, select and hold **Menu**. Select **Options** and from the following options:

Topic list – to view a list of available topics in the appropriate category

Help category list – to view a list of help categories

Search by keyword – to search for help topics using keywords

To open help from the main menu, select **Menu** > **Applications** > **Help**. In the list of help categories, select the desired application to view a list of help topics. To switch between the help category list, indicated with , and a keywords list, indicated with  abc, scroll left or right. To display the related help text, select it.

Issues with your device

If you have operational issues with your device, try the following before taking it to a service point:

Reset the device

Switch the device off, remove the battery, reinsert it, and switch the device on.

Restore original factory settings

Select **Menu** > **Settings** > **Phone sett.** > **General** > **Factory settings**. Your documents and files are not deleted.

Update your device software

Nokia may produce software updates that may offer new features, enhanced functions, or improved performance. You may be able to request these updates through the Nokia Software Updater PC application. To update the device software, you need the Nokia Software Updater application and a compatible PC with Microsoft Windows 2000 or XP operating system, broadband internet access,

and a compatible data cable to connect your device to the PC.

To get more information and to download the Nokia Software Updater application, visit www.nokia-asia.com/softwareupdate or your local Nokia website.

If software updates over the air are supported by your network, you may also be able to request updates through the device. See "[Update software](#)," p. 97.

Downloading software updates may involve the transmission of large amounts of data through your service provider's network. Contact your service provider for information about data transmission charges.

Make sure that the device battery has enough power, or connect the charger before starting the update.

Get started

Insert a SIM or USIM card and battery

Always switch the device off and disconnect the charger before removing the battery.

This device uses BP-5M batteries.

With the back of the device facing you, press the back cover release button (1), and lift the back cover to remove it (2).

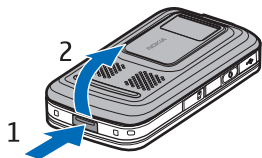

To remove the battery, lift it as shown (3).

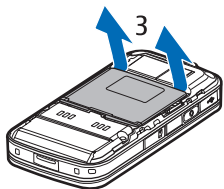

To release the SIM card holder, gently pull the locking clip of the card holder, and open it (4). Insert the SIM or USIM card to the SIM card holder (5). Make sure that the SIM or USIM card is properly inserted and that the gold-colored contact area on the card is facing downwards. Close the SIM card holder, and press it until it snaps into position (6).

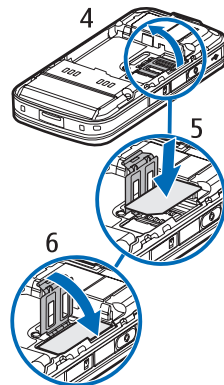

Replace the battery (7).

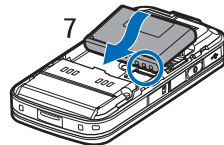

Press the back cover into place (8).

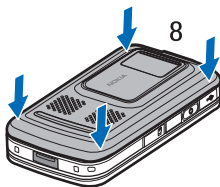

microSD card

Use only compatible microSD cards approved by Nokia for use with this device. Nokia uses approved industry standards for memory cards, but some brands may not be fully compatible with this device. Incompatible cards may damage the card and the device and corrupt data stored on the card.



Keep microSD cards out of the reach of small children.

You can extend the available memory with a microSD memory card. You can insert or remove a microSD card without switching the device off.



Important: Do not remove the memory card in the middle of an operation when the card is being accessed. Removing the card in the middle of an operation may damage the memory card as well as the device, and data stored on the card may be corrupted.

Insert a memory card

Note that a memory card, including a map, may already be inserted in the device.

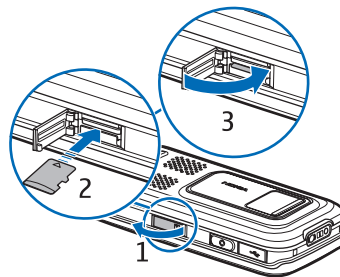

1. With the back of the device facing upward, open the memory card slot door.
2. Place the memory card in the slot with the gold-colored contact area facing down. Push the card gently to lock it into place.
3. Close the memory card slot door.

Remove a memory card

1. Open the memory card slot door.
2. Push the card gently to release it. Wait until **Remove memory card and press 'OK'** is displayed. Pull the card out.
3. Close the memory card slot door.

Charge the battery

Connect the charger to a wall socket. Connect the charger to the device.

If the battery is completely discharged, it may take a few minutes before the charging indicator appears on the display or before any calls can be made.

The charging time depends on the charger and the battery used. Charging a BP-5M battery with the AC-4 charger takes approximately 80 minutes.

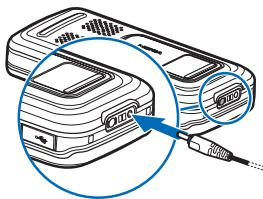

Switch the device on or off

Press and hold the end key.

If the device asks for a PIN code, open the slide, enter the PIN code, and select **OK**.

If the device asks for the lock code, enter the lock code, and select **OK**. The factory setting for the lock code is 12345.



Set time and date

To set the correct time zone, time, and date, select the country you are in, and enter the local time and date.

Normal operating position

Use the device only in its normal operating position.

During extended operation, such as an active video call or high speed data connection, the device may feel warm. In most cases, this condition is normal. If you suspect the device is not working properly, take it to the nearest authorized service facility.



Cellular antenna (1)
Bluetooth antenna (2)
GPS antenna (3)

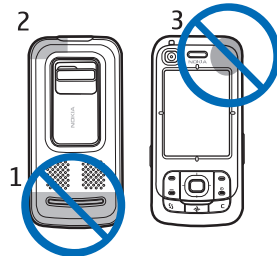

Your device may have internal and external antennas. As with any radio transmitting device, avoid touching the antenna area unnecessarily while the antenna is transmitting or receiving. Contact with such an antenna affects the communication quality and may cause the device to operate at a higher power level than otherwise needed and may reduce the battery life.

Configuration settings

Before you can use multimedia messaging, instant messaging, push to talk, e-mail, synchronization, streaming, and the browser, you must have the proper configuration settings on your device. Your device may automatically configure browser, multimedia messaging, access point, and streaming settings based on the SIM card used. You may also receive the settings directly as a configuration message, which you save to your device. For more information on availability, contact your service provider or nearest authorized Nokia dealer.

When you receive a configuration message, and the settings are not automatically saved and activated, **1 new message** is displayed. Select **Show** to open the message. To save the settings, select **Options > Save**. You may need to enter a PIN code provided by the service provider.

Your phone

Keys and parts

- Light sensor (1)
- Earpiece (2)
- Secondary camera lens (3)
- Display (4)
- Left and right selection keys (5)
- End key and power key (6), hereafter referred to as end key
- Call key (7)
- Menu key (8)
- Clear key (9)
- Navigator key (10)
- Navi™ scroll key (11), hereafter referred to as scroll key
- Number keys (12)

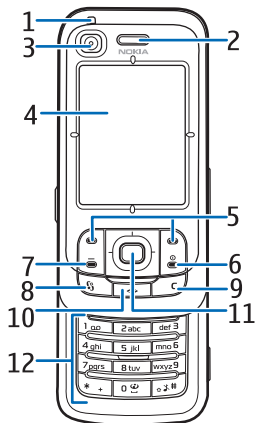

- USB mini-B connector (13)
- My own key (14)
- microSD card slot (15)
- Microphone (16)
- Back cover release button (17)
- Loudspeakers (18)
- Camera slide cover (19)
- Main camera lens (20)
- Camera flash (21)
- Nokia AV connector (2.5 mm) (22)
- Charger connector (23)
- Volume keys (24)
- Camera key (25)

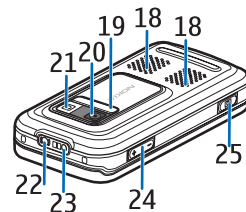
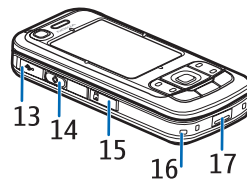

Warning: This device may contain nickel.

Standby mode

When you have switched on the device, and it is registered to a network, the device is in the standby mode and ready for use.

To change the profile, press the end key, and select a profile.

To open the list of last dialed numbers, press the call key.

To start a connection to the web, press and hold **0**.

Active standby

When active standby is enabled, you can use the display for fast access to frequently used applications. To select whether the active standby is shown, select **Menu** > **Settings** > **Phone sett.** > **General** > **Personalisation** > **Standby mode** > **Active standby** > **On** or **Off**.

To access active standby applications, scroll up or down, then scroll to the application, and select it. In active standby the default applications are shown across the top of the active standby area, and calendar, to-do, and player events are listed below. To select an application or event, scroll to it, and select it.

Indicators

3G
3.5G

The device is connected to a UMTS network.
The HSDPA (network service) in UMTS network is activated.



The device is connected to a GSM network.



The device is in offline mode and not connected to a cellular network.



The GPS receiver is active.



You have received one or several messages to the **Inbox** folder in **Messaging**.



You have received new e-mail in your remote mailbox.



There are messages waiting to be sent in **Outbox**. See "**Outbox**", p. 43.



You have missed calls. See "**Recent calls**", p. 29.



Shown if **Ringing type** is set to **Silent** and **Message alert tone** and **E-mail alert tone** are set to **Off**. See "**Profiles**", p. 73.



The device keypad is locked. See "**Keypad lock (keyguard)**", p. 21.



The loudspeaker is activated.



















An alarm is active.



The second phone line is being used. See **Line in use** in "**Call**", p. 79.



All calls to the phone are diverted to your call mailbox or to another number. If you have two phone lines, the divert indicator is **1** for the first line and **2** for the second.

-  A headset is connected to the device.
-  A loopset is connected to the device.
-  The connection to a Bluetooth headset has been lost.
- D / D+** A data call is active.
-  A GPRS packet data connection is active.  indicates the connection is on hold and  that a connection is available.
-  A packet data connection is active in a part of the network that supports EGPRS.  indicates the connection is on hold and  that a connection is available. The icons  indicate that EGPRS is available in the network, but your device is not necessarily using EGPRS in the data transfer.
-  A UMTS packet data connection is active.  indicates the connection is on hold and  that a connection is available.
-  Bluetooth is switched on.
-  Data is being transmitted using Bluetooth. See "[Bluetooth connection](#)", p. 87.
-  A USB connection is active.

Other indicators may also be shown. For push-to-talk indicators, see "[Push to talk](#)", p. 91.

Menu

In the menu you can access the functions in your device.

To access the main menu, select **Menu**.

To open an application or a folder, scroll to it by pressing the edges of the scroll key, and press the scroll key.

To change the menu view, select **Menu > Options > Change Menu view** and a view type.

If you change the order of the functions in the menu, the order may differ from the default order described in this user guide.

To close an application or a folder, select **Back** and **Exit** as many times as needed to return to the main menu, or select **Options > Exit**.

To display and switch between open applications, select and hold **Menu**. The application switching window opens, showing a list of open applications. Scroll to an application, and select it.

To mark or unmark an item in applications, press #. To mark or unmark several consecutive items, press and hold #, and scroll up or down.

Leaving applications running in the background increases the demand on battery power and reduces the battery life.

Welcome application

Welcome application starts when you switch on your device for the first time. With the **Welcome** application, you can access the following applications:

Tutorial – Learn about the features of your device and how to use them.

Sett. wizard – Configure connection settings.

Transfer – Copy or synchronize data from other compatible devices.

To open **Welcome** later, select **Menu > Applications > Welcome**.

Volume control

To adjust the earpiece or loudspeaker volume during a call or when listening to an audio file, press the volume keys.

To activate the loudspeaker during a call, select **Loudspeaker**.

To deactivate the loudspeaker during a call, select **Handset**.



Warning: Do not hold the device near your ear when the loudspeaker is in use, because the volume may be extremely loud.

Keypad lock (keyguard)

To lock the keypad when the slide is closed, select **Menu > Settings > Phone sett. > General > Slide handling > Keyguard activation > On when closing slide**. See "**Slide handling**", p. 76.

When the keypad is locked and the main display light is off, to activate the main display light, open the slide. Opening the slide also unlocks the keypad.

To unlock the keypad when the slide is closed, select **Unlock** and **OK** within 1.5 seconds. Also opening the main camera lens cover unlocks the keypad.

When the device or keypad is locked, calls may be possible to the official emergency number programmed into your device.

Access codes

Lock code

The lock code (5 digits) helps to protect your device against unauthorized use. The preset code is 12345. Change the code, and keep the new code secret and in a safe place separate from your device. To change the code and to set the device to request the code, see "**Security**", p. 77.

If you enter an incorrect lock code five times in succession, the device ignores further entries of the code. Wait for 5 minutes, and enter the code again.

When the device or keypad is locked, calls may be possible to the official emergency number programmed into your device.

PIN codes

The personal identification number (PIN) code and the universal personal identification number (UPIN) code (4 to 8 digits) help to protect your SIM card against unauthorized use. See "[Security](#)", p. 77. The PIN code is usually supplied with the SIM card.

The PIN2 code (4 to 8 digits) may be supplied with the SIM card and is required for some functions.

The module PIN is required to access the information in the security module. The module PIN is supplied with the SIM card if the SIM card has a security module in it.

The signing PIN is required for the digital signature. The signing PIN is supplied with the SIM card if the SIM card has a security module in it.

PUK codes

The personal unblocking key (PUK) code and the universal personal unblocking key (UPUK) code (8 digits) are required

to change a blocked PIN code and UPIN code, respectively. The PUK2 code is required to change a blocked PIN2 code.

If the codes are not supplied with the SIM card, contact your local service provider for the codes.

Barring password

The barring password (4 digits) is required when using [Call barring](#). See "[Call barring](#)", p. 81. You can obtain the password from your service provider.

If you enter an incorrect barring password three times in succession, the password is blocked. Contact your service provider.

My own key

To configure the my own key to open applications such as the message reader when pressing the key, select [Menu](#) > [Settings](#) > [Phone sett.](#) > [General](#) > [My own key](#) > [My own key](#), scroll to the desired application, and select it.

To give voice commands, press and hold the my own key.

To activate push to talk, press the my own key. The push to talk connection must be started before it can be activated with the my own key. See "[Push to talk](#)", p. 91.

When push to talk is started, the my own key functions as a push-to-talk key, overrides voice commands and the configured application, and activates push to talk.

Attach a wrist strap

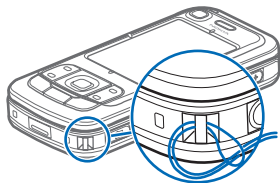

Connect a compatible headset

Do not connect products that create an output signal as this may cause damage to the device. Do not connect any voltage source to the Nokia AV connector.

When connecting any external device or any headset, other than those approved by Nokia for use with

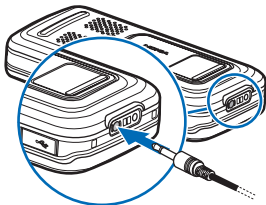

this device, to the Nokia AV connector, pay special attention to volume levels.

Connect a USB data cable

To set the default mode and select whether the default mode is activated automatically, see "[USB data cable](#)", p. 89.

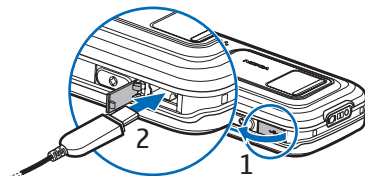

Call functions

Make a call

- 1 In the standby mode, enter the phone number, including the area code. Press the clear key to remove a number.

For international calls, press * twice for the international prefix (the + character replaces the international access code), and enter the country code, area code (omit the leading zero if necessary), and phone number.

- 2 To call the number, press the call key.
To adjust the volume during the call, press the volume keys.
- 3 To end the call, or to cancel the call attempt, press the end key.

To make a call from **Contacts**, select **Menu > Contacts**. Scroll to the desired name; or enter the first letters of the name, and scroll to the desired name. To call the number, press the call key.

To call your call mailbox (network service), press and hold 1 in the standby mode. You must define the call mailbox number before you can call your call mailbox. See "[Call mailbox](#)", p. 84.

To call a recently dialed number, press the call key in the standby mode. The list of the last 20 numbers you called or attempted to call is shown. Scroll to the number you want, and press the call key.

To make a push to talk call, see "[Push to talk](#)", p. 91.

Speed dialing

You can assign a phone number to one of the speed dialing keys, 2 to 9. See "[Assign speed dialing keys](#)", p. 49.

Call a speed dialing number in either of the following ways:

- Press the speed dialing key, then the call key.
- If **Speed dialing** is set to **On**, press and hold the speed dialing key until the call begins. To set **Speed dialing** to **On**, select **Menu > Settings > Phone sett. > Phone > Call > Speed dialing > On**.

Voice dialing

A voice tag is added automatically to all entries in **Contacts**.

Use long names, and avoid similar names for different numbers.

Before using voice tags, note the following:

- Voice tags are not language-dependent. They are dependent on the speaker's voice.
- You must say the name exactly as you said it when you recorded it.
- Voice tags are sensitive to background noise. Record voice tags and use them in a quiet environment.
- Very short names are not accepted. Use long names, and avoid similar names for different numbers.



Note: Using voice tags may be difficult in a noisy environment or during an emergency, so you should not rely solely upon voice dialing in all circumstances.

- 1 In the standby mode, press and hold the my own key. A short tone is played, and **Speak now** is displayed. If you are using a compatible headset with the headset key, press and hold the headset key.
- 2 Speak the voice command clearly. The device plays the voice command of the best match. After 1.5 seconds, the device dials the number; if the result is not the correct one, before dialing, scroll to another entry.

Using voice commands to carry out a device function is similar to voice dialing. See "[Voice commands](#)", p. 74.

Make a conference call (network service)

- 1 Make a call to the first participant.
- 2 To make a call to another participant, select **Options > New call**. The first call is automatically put on hold.
- 3 To join the first participant in the conference call when the new call is answered, select **Options > Conference**.
 - To add a new person to the call, repeat step 2, and select **Options > Conference > Add to conference**. The device supports conference calls between a maximum of six participants, including yourself.
 - To have a private conversation with one of the participants, select **Options > Conference > Private**. Select a participant and **Private**. The conference call is put on hold on your device. The other participants can still continue the conference call. To return to the conference call, select **Options > Add to conference**.
 - To drop a participant, select **Options > Conference > Drop participant**, scroll to the participant, and select **Drop**.
- 4 To end the conference call, press the end key.

Answer or reject a call

To answer a call, press the call key.

To determine whether calls are answered automatically when opening the slide, select **Menu > Settings > Phone sett. > General > Slide handling > Opening the slide > Answer incoming call or Call not answered**. See "Slide handling", p. 76.

To adjust the volume during the call, press the volume keys.

To mute the ringing tone, select **Silence**.



Tip: If a compatible headset is connected to the device, press the headset key to answer and end a call.

To reject the call, press the end key. The caller hears a line busy tone. If you have activated the call divert option **If busy** to divert calls, rejecting the call diverts the call.

To send a text message to inform the caller as to why you cannot answer the call, select **Options > Send text message**. You can edit the text before you send it. See **Reject call with SMS** and **Message text** in "Call", p. 79.

Note that when a headset is connected, the slide call handling settings are not in use.

Answer a video call

When a video call arrives,  is displayed.

Press the call key to answer the video call. **Allow video image to be sent to caller?** is shown. If you select **Yes**, the image captured by the camera in your device is shown to

the caller. If you select **No**, or do nothing, video sending is not activated, and a grey screen is shown in place of the video.

Even if you have denied video sending during a video call, the call is still charged as a video call. Check the pricing with your service provider.

To end the video call, press the end key.

Call waiting (network service)

During a call, to answer the waiting call, press the call key. The first call is put on hold. To end the active call, press the end key.

To activate the call waiting function, select **Menu > Settings > Phone sett. > Phone > Call > Call waiting > Activate**.

To switch between the two calls, select **Swap**.

Options during a call

Many of the options that you can use during a call are network services. For availability, contact your service provider.

Select **Options** during a call for some of the following options:

Transfer – to connect a call on hold to an active call and disconnect yourself

Replace – to end an active call and replace it by answering the waiting call

Send DTMF – to send DTMF tone strings (for example, a password). Enter the DTMF string or search for it in

Contacts. To enter a wait character (**w**) or a pause character (**p**), press * repeatedly. To send the tone, select **OK**.



Tip: You can add DTMF tones to the phone number or DTMF fields in a contact card.

Make a video call

When you make a video call, you can see a real-time, two-way video between you and the recipient of the call. The live video image or video image captured by the camera in your device is shown to the video call recipient.

To be able to make a video call, you must be in the coverage of a UMTS network. You may need to use a USIM card to make video calls. For availability of and subscription to video call services, contact your service provider. A video call can only be made between two parties. The video call can be made to a compatible mobile phone or an ISDN client. Video calls cannot be made while there is another voice, video, or data call active.

Icons:

 You are not receiving video (the recipient is not sending video or the network is not transmitting it).

 You have denied video sending from your device.

- 1 Enter the phone number in the standby mode; or select **Menu > Contacts**, and scroll to the desired contact.
- 2 Select **Options > Call > Video call**.

Starting a video call may take a while. **Waiting for video image** is shown. If the call is not successful (for example, video calls are not supported by the network, or the receiving device is not compatible), you are asked if you want to try a normal call or send a message instead.

The video call is active when you see two video images, and hear the sound through the loudspeaker. The call recipient may deny video sending () , in which case you hear the sound and may see a still image or a grey background graphic.

To increase or decrease the volume during a call, press the volume keys.

To change between showing video or only hearing sound, select **Enable** or **Disable > Sending video, Sending audio, or Sending aud. & video**.

To zoom in or out on your own image, select **Zoom in** or **Zoom out**. The zoom indicator is shown on the top of the display.

To switch the places of the sent and received video images on the display, select **Change image order**.

Even if you have denied video sending during a video call, the call will still be charged as a video call. Check the pricing with your network operator or service provider.

To end the video call, press the end key.

Video sharing

To send live video from your mobile device to another compatible mobile device during a voice call, select **Video sharing**.

Video sharing requirements

Because **Video sharing** requires a 3G universal mobile telecommunications system (UMTS) connection, your ability to use **Video sharing** depends on 3G network availability. Contact your service provider for questions about network availability and fees associated with this application. To use **Video sharing** you must do the following:

- Ensure that your device is set up for person-to-person connections, also known as session initiation protocol (SIP). Ask your service provider for SIP settings and save them in your phone. If you know a recipient's SIP address, you can enter it on your contact card for that person, select **Menu > Contacts**, a contact, and **Options > Edit > Options > Add detail > Share view**.

Enter the SIP address in the format sip:username@domainname (you can use an IP address instead of a domain name).

- Ensure you have an active UMTS connection and are within UMTS network coverage. If you start the sharing session while you are within UMTS network coverage and a handover to GSM occurs, the sharing session is discontinued, but your voice call continues.
- Ensure that both the sender and recipient are registered to the UMTS network. If you invite someone to a sharing session and that person's device is turned off, or the person is not within UMTS network coverage, they do not know that you are sending an invitation. However, you receive an error message that the recipient cannot accept the invitation.

Share video

To receive a sharing session, the recipient must install **Video sharing** and configure the required settings on their mobile device. You and the recipient must both be registered to the service before you can start sharing.

Live video

- 1 When a voice call is active, select **Options > Share video > Live video**.
- 2 The device sends the invitation to the SIP address you have added to the contact card of the recipient.

If the recipient has several SIP addresses in the contact card, select the SIP address to which you want to send the invitation, and **Select** to send the invitation.

If the SIP address of the recipient is not available, enter a SIP address. Select **OK** to send the invitation.

- 3 Sharing begins automatically when the recipient accepts the invitation.
The loudspeaker is active. You can also use a headset to continue your voice call while you share live video.
- 4 Select **Pause** to pause the sharing session. Select **Continue** to resume sharing.
- 5 To end the sharing session, select **Stop**. To end the voice call, press the end key.

Accept an invitation

When someone sends you a share invitation, an invitation message is displayed showing the sender's name or SIP address. If your device is not set to **Silent**, it rings when you receive an invitation.

If someone sends you a share invitation and you are not within UMTS network coverage, you will not know that you received an invitation.

When you receive an invitation, select **Accept** to begin the sharing session, or **Reject** to decline the invitation. The sender receives a message that you rejected the invitation. You can also press the end key to decline the sharing session and disconnect the voice call.

To end the sharing session, select **Stop**.

Log

In the log, you can monitor phone calls, text messages, packet data connections, and fax and data calls registered by the device.

Connections to your remote mailbox, multimedia messaging centre, or browser pages are shown as data calls or packet data connections in the general communications log.



Note: The actual invoice for calls and services from your service provider may vary, depending on network features, rounding off for billing, taxes, and so forth.



Note: Some timers, including the life timer, may be reset during service or software upgrades.

Recent calls

The device registers the phone numbers of missed, received, and dialed calls, and the approximate duration of your calls. The device registers missed and received calls only if the network supports these functions, and the device is switched on and within the network service area.

To view recent calls (network service), select **Menu > Log > Recent calls** and a call type.

To clear all recent call lists in the **Recent calls** view, select **Options > Clear recent calls**. To clear only one of the call registers, open the register you want to erase, and select **Options > Clear list**.

General log

To view the general log, select **Menu > Log**, and scroll right.

To filter the log, select **Options > Filter** and the filter type.

To erase all the log contents permanently, select **Options > Clear log > Yes**.

Navigator

Your device has an internal GPS receiver that receives low-power radio signals from satellites, and measures the travel time of the signals. From the travel time, the GPS receiver can calculate its location to within a few meters. The coordinates are expressed in degrees and decimal degrees format using WGS-84 coordinate system.

The GPS receiver is located in the upper right corner of the slide cover. When using the receiver, hold the device upright in your hand with an orientation toward the sky.

Note that establishing a GPS connection may take several minutes.

As availability of GPS related services depends on wireless environment and systems, the services may not function in all environments at all times. In case of sudden loss of GPS reception, press the Navigator key to restart the application.

Your device also supports Assisted GPS (A-GPS) service which helps determining the location faster. It utilizes packet data connection, and your network operator may



charge you for this according to your network subscription. Contact your service provider for the correct internet access point and charges related to the service.

Assisted GPS (A-GPS) is used to retrieve assistance data over a packet data connection, which assists in calculating the coordinates of your current location when your device is receiving signals from satellites.

Your device is preconfigured to use the Nokia A-GPS service if no service provider specific A-GPS settings are available. The assistance data is retrieved from the Nokia A-GPS service server only when needed.

When you start the GPS function for the first time, you need to define or select an access point to take A-GPS into use. After this, A-GPS is used automatically when needed unless the A-GPS method is disabled. For example, the A-GPS service will be contacted automatically if the integrated GPS has been switched off for more than two hours.

To enable or disable different positioning methods, such as the A-GPS, select **Menu > Settings > Phone sett. > General > Positioning > Positioning methods**, scroll to the positioning method, and select **Options > Enable** or **Disable**.

The Global Positioning System (GPS) is operated by the government of the United States, which is solely responsible for its accuracy and maintenance. The accuracy of location data can be affected by adjustments to GPS satellites made by the United States government and is subject to change with the United States Department of Defense civil GPS policy and the Federal Radionavigation Plan. Accuracy can also be affected by poor satellite geometry. Availability and quality of GPS signals may be affected by your location, buildings, natural obstacles, and weather conditions. The GPS receiver should only be used outdoors to allow reception of GPS signals.

Any GPS should not be used for precise location measurement, and you should never rely solely on location data from the GPS receiver and cellular radio networks for positioning or navigation.

Almost all digital cartography is inaccurate and incomplete to some extent. Never rely solely on the cartography provided for use in this device.

If your device cannot find the satellite signal, consider the following:

- If you are indoors, go outdoors to receive a better signal.
- If you are outdoors, move to a more open space.
- Check that your hand does not cover the GPS antenna of your device.

- If the weather conditions are bad, in such a case the signal strength may also be affected.
- Establishing a GPS connection may take several minutes.

Navigator application

To start the Navigator application, press the Navigator key, or select **Menu > Navigator**.

With the Navigator application, you can navigate, search places and routes, and plan trips. You receive voice guidance and visual travel instructions with the map turn-by-turn during your trip.

When you launch the Navigator application, it zooms to the last known position and displays **Getting position** until the GPS receiver is able to calculate your position.

Navigator key

You can use the Navigator key as a shortcut to different functions depending on the state of the Navigator application when you press the key.

- If the Navigator application is not running, the Navigator key starts the application.
- If the Navigator application is on the display but not showing the current position, the Navigator key moves the map to current position.

- If the Navigator application is in the foreground showing the current position, the Navigator key opens the navigation function.
- If the Navigator application is running in the background, the Navigator key brings the application to the display and goes to the GPS position on map.

Keypad shortcuts in the Navigator application

- 1 – Open the **Search** view.
 - 2 – Change view layout.
 - 3 – Toggle between Day colors and Night colors.
 - 4 – Show or hide the progress bar (only when navigating).
 - 5 – Show or hide the **GPS information** view.
 - 6 – Toggle between 2-D and 3-D perspective.
 - 7 – Open the **Free text** search view.
 - 8 – Zoom to the entire map.
 - 9 – Toggle between sound on and off.
 - 0 – Repeat the previous voice instruction (only when navigating).
 - * or # – Zoom in or out on the map. The minimum is street level and the maximum is the globe.
- To move on the map, scroll left, right, up, or down.

Navigate to locations

To define a travel mode in the Navigator application, select **Options > Travel mode** and **As fast as possible**, **As short as possible** or **Pedestrian**. To define more detailed travel conditions, select **Options > Settings > Navigation**. Travel mode can be changed at any time during navigation.

Navigate to a destination

- 1 In the Navigator application, select **Options > Navigate** and a navigation option. For example, to search an address, select **Address**; or to search a point-of-interest (POI), select **Nearby**.
You can also search for a destination in the map view by scrolling the cursor to the desired destination.
- 2 To start navigating, select the destination from the list of results or from the map view, and select **Navigate to**. If navigation is in progress and you want to start a new one, select **Yes** when the confirmation query is asked. To continue a previous navigation and return to the map view, select **No**.
- 3 To stop the current navigation, press the clear key, or select **Options > Stop navigation > Yes** to the confirmation query. To continue the navigation, select **No**.

To add a waypoint to a navigation in progress:

- 1 Search and select a waypoint from the list of results or from the map view.
- 2 Select **Navigate via**. If there is no intermediary waypoint defined for the trip, the navigation continues automatically.

If an intermediary waypoint has been defined, a confirmation query is displayed. To continue the navigation with the new waypoint, select **Yes**, or to continue the navigation with the old waypoint, select **No**.

Alarms

To receive a visual or acoustic alarm when approaching a certain location, select **Options > Settings > Alarm** and the category to which the location belongs. For example, select **Points-of-interest** and mark the the desired subcategories.

Set road blocks

To avoid a certain part of the planned route when navigating, select **Options > Define road block** and the distance for which you want to set the road block.

To define the part to be avoided in the **Route description** view, select **Select from list**.

Browse the map

When not navigating, you can use the Navigator application to browse the map, and search places and locations (for example, by address). A GPS signal is not required when browsing the map.

View location information

To view a searched item and information about it on the map view, select the item from the list and **Show on map**.

Information can also be viewed by scrolling to the desired location on the map, selecting it and **Show information**.

To call to a number of a selected location, select **Call**. To use the call function, select the item from the list of search results or in the map view.

Send and save location information

To send location data (such as a map as an image), route itinerary, or your current GPS position to a compatible device, select **Options > Send** and the data to be sent. The information channel depends on the data, for example, a map as an image can be sent as a multimedia or e-mail message or through a Bluetooth connection.

To send your cursor position on the map to a compatible device, for example as an SMS or MMS, select it and **Send cursor position** > **Via text message** or **Via multimedia**.

To save data, such as current GPS or cursor position to your device, select **Options** > **Save** and the data to be saved.

You can add a location, for example, a cursor position, in **Contacts**. Select **Save cursor position** > **New contact**.

Plan trips

- 1 In the Navigator application, select **Options** > **Trips** > **Plan new route**. Enter the route name, and select **Save**.
- 2 Select **Departure** > **Set departure** to search, and select the departure point of the trip.
- 3 Select **Destination** > **Set destination** to search, and select the destination point of the trip.
- 4 To add waypoints to your route, select **Options** > **Add waypoint**, and search and select the waypoint to be added.
- 5 To start the trip, select **Options** > **Start navigation** and the first visit of the trip.
If navigation is in progress and you want to start a new navigation, a confirmation is asked. To abort the ongoing navigation and start the new trip, select **Yes**. To continue the previous navigation, select **No**.

To change the order of the waypoints, select the waypoint to be moved, **Options** > **Move**, and the direction to which you want to move the waypoint.

Settings

To change the Navigator application settings, select **Options** > **Settings** and the feature you wish to modify. For example, to choose specific points-of-interest to be displayed on the map, select **Map** > **Show points-of-interest** and the desired categories.

To configure the behaviour of voice instructions during a phone call, select **Navigation** > **Call handling** > **Dim instructions** to set the voice instructions to a lower level than the phone conversation, **Call and instructions** to have the voice instructions and telephone conversation on the same volume level, or **Beep for instruction** to replace the voice instructions with a beep.

For detailed information about the settings, see the Navigator help. To access the help, select **Settings** > **Options** > **Help**.

Extras

To complement your device, download maps from the internet to your PC and use the Nokia Map Manager application (an add-on application to PC Suite) to transfer

the maps from your PC or a DVD to a memory card in your device, see "[Transfer maps from PC](#)", p. 36.

You can also use the Navigator application to download smaller amounts of data (network service), such as travel guides and traffic and weather information to a memory card in your device. Before you can use the maps or other contents, you must purchase licenses, for example, with the Navigator application.

In case of problems with purchased contents, try synchronising the licenses. Select **Extras > Options > Synchronise license keys**.

Extra services are provided by a third-party service provider. Availability depends on the country, operator, and local legislation.

Transfer maps from PC

The requirements of the PC for map transfer are as follows:

- Microsoft Windows XP operating system (or later)
- Nokia PC Suite 6.82 or later
- Nokia Map Manager application (an add-on to PC Suite)



To transfer maps between a PC and a memory card, for example, when copying memory card contents to a new memory card, use Nokia Map Manager. Connect your

device to a PC with a compatible USB cable, and select **PC Suite** as the connection mode.

To change the default USB connection mode, select **Menu > Settings > Connectivity > USB > USB mode**.

Nokia Map Manager is optimized for transferring map files. For information about transferring maps with Nokia Map Manager, see the Nokia Map Manager help.

Write text

When you write text,  appears on the top right of the display, indicating predictive text input, or  appears, indicating traditional text input. To set the predictive text input on or off when writing text, press # repeatedly until the desired mode is active.

Abc. abc, or **ABC** is displayed next to the text input indicator, indicating the character case. To change the character case, press #.

123 indicates the number mode. To change between letter and number mode, press # repeatedly until the desired mode is active.

Traditional text input

Press a number key, **1** to **9**, repeatedly until the desired character appears. Not all characters available under a number key are printed on the key. The availability of characters depends on the selected writing language. See [Writing language](#) in "Language", p. 75.

If the next letter you want is on the same key as the present one, wait until the cursor appears (or scroll forward to end the time-out period), and enter the letter.

To insert a number, press and hold the number key.

The most common punctuation marks and special characters are available under the **1** key. For more characters, press and hold *.

To erase a character, press the clear key. To erase more characters, press and hold the clear key.

To insert a space, press **0**. To move the cursor to the next line, press **0** three times.

Predictive text input

To enter any letter with a single keypress, use predictive text input. To activate predictive text input, press # repeatedly until  appears. This activates predictive text input for all editors in the device.

- 1 To write the desired word, press the keys **2–9**. Press each key only once for one letter. The word changes after every keypress.
For the most common punctuation marks, press **1**. For more punctuation marks and special characters, press and hold *.
To erase a character, press the clear key. To erase more characters, press and hold the clear key.

Write text

- 2 When you have finished the word and it is correct, to confirm it, scroll forward or insert a space.
If the word is not correct, to view the matching words the dictionary has found one by one, press * repeatedly. If the? character is shown after the word, the word you intended to write is not in the dictionary. To add a word to the dictionary, select **Spell**. Enter the word (up to 32 letters) using traditional text input, and select **OK**. The word is added to the dictionary. When the dictionary becomes full, a new word replaces the oldest added word.

If you want to delete the selected text, press the clear key.

- 3 To insert the text, scroll to the insertion point, press and hold #, and at the same time select **Paste**.

Write compound words

Write the first half of a compound word, and scroll forward to confirm it. Write the last part of the compound word, and to complete the compound word, press 0 to add a space.

Copy and delete text

- 1 To select letters and words, press and hold #, and at the same time scroll left or right. As the selection moves, text is highlighted. To select lines of text, press and hold #, and at the same time scroll up or down.
- 2 To copy the text to the clipboard, press and hold #, and at the same time select **Copy**.

Messaging

To open the **Messaging** menu, select **Menu > Messaging**. You can see the **New message** function and a list of default folders:

 **Inbox** – contains received messages except e-mail and cell broadcast messages. E-mail messages are saved in the **Mailbox** folder. To read cell broadcast messages, select **Options > Cell broadcast**.

 **My folders** – for organizing your messages into folders

 **Mailbox** – for connecting to your remote mailbox to retrieve your new e-mail messages or viewing your previously retrieved e-mail messages offline. After you define settings for a new mailbox, the name given to that mailbox is displayed instead of **Mailbox**.

 **Drafts** – saves draft messages that have not been sent

 **Sent** – saves the messages that are sent, excluding messages sent using Bluetooth. See **Save sent messages** in **"Other settings"**, p. 46.

 **Outbox** – temporarily saves the messages waiting to be sent

 **Reports** (network service) – saves the delivery reports of the text messages, special message types such as business cards, and multimedia messages you have sent. Receiving a delivery report of a multimedia message that has been sent to an e-mail address may not be possible.

Write and send messages

The wireless network may limit the size of MMS messages. If the inserted picture exceeds this limit, the device may make it smaller so that it can be sent by MMS.

Your device supports text messages beyond the limit for a single message. Longer messages are sent as two or more messages. Your service provider may charge accordingly. Characters with accents or other marks, and characters from some language options, take up more space, and limit the number of characters that can be sent in a single message.

Only devices that have compatible features can receive and display multimedia messages. The appearance of a message may vary depending on the receiving device.

Before you can send and receive an SMS message, a multimedia message, or an e-mail, or connect to your remote mailbox, you must have the correct connection settings in place. See "Messaging settings", p. 43.

- 1 To create a message, select **Menu > Messaging > New message** and the message type.
To create an audio message, see "Nokia Xpress audio messaging", p. 40.
- 2 Select the recipients or groups from **Contacts**, or enter the phone number or e-mail address of the recipient in the **To** field. Separate recipients with a semicolon (;).
- 3 When creating an e-mail or multimedia message, scroll down to the subject field, and write the message subject.
- 4 Scroll down to move to the message field.
- 5 Write the message.

When writing text messages, the message length indicator shows how many characters you can enter in the message. For example, 10 (2) means that you can still add 10 characters for the text to be sent as two separate text messages.

To use a template for the text message, select **Options > Insert > Template**. To create a presentation based on a template to be sent as a multimedia message, select **Options > Create presentation**. To use a text template for the multimedia message, select **Options > Insert object > Template**.

To add a media object to a multimedia message, select **Options > Insert object > Image, Sound clip, or Video clip**. To create and add a new media object, select **Options > Insert new > Image, Sound clip, Video clip or Slide**. When sound is added,  is shown.
To add a media object to an e-mail, select **Options > Insert > Image, Sound clip, Video clip, Note or Template**.

- 6 To send the message, select **Options > Send**.

Nokia Xpress audio messaging

Audio messages are multimedia messages that consist of a single sound clip. To create and send an audio message do the following:

1. Select **Menu > Messaging > New message > Audio message**.
2. In the **To** field, select the recipients from **Contacts**, or enter the phone number or e-mail address. Scroll down to the message field.
3. To record a new sound clip, select **Options > Insert sound clip > New sound clip**. The recording will start.

To use a previously recorded sound clip, select **Options > Insert sound clip > From Gallery**, scroll to the sound clip, and select it. The sound clip has to be in .amr format.

To play the sound clip, select **Options > Play sound clip**.

4. To send the message, select **Options > Send**.

E-mail settings

Before you can send, receive, retrieve, reply to, and forward e-mail to a separate e-mail account, you must configure an internet access point (IAP) and define your e-mail settings correctly, see "Connection," p. 81 and "E-mail settings," p. 45.

Follow the instructions given by your e-mail service provider and internet service provider.

Inbox—receive messages

Select **Menu > Messaging > Inbox**.

When there are unread messages in the inbox, the icon changes to .

To open a received message, select **Menu > Messaging > Inbox** and the desired message.

View multimedia objects

To view the list of media objects that are included in the multimedia message, open the message, and select **Options > Objects**. You can save the file in your device or

send it using Bluetooth technology or as a multimedia message to another compatible device.

Special message types

Your device can receive many kinds of messages, such as operator logos, business cards, calendar entries, and ringing tones.

To open a received message, select **Menu > Messaging > Inbox** and the desired message. You can save the special message content to your device. For example, to save a received calendar entry to the calendar, select **Options > Save to Calendar**.

The appearance of a message may vary depending on the receiving device.

Service messages

Service messages (network service) are notifications (for example, news headlines) that may contain a text message or the address of a browser service. For availability and subscription, contact your service provider.

My folders

You can organize your messages into folders, create new folders, and rename and delete folders.

Select **Menu > Messaging > My folders**. To create a folder, select **Options > New folder**, and enter a name for the folder.

Mailbox

Select **Menu > Messaging > Mailbox. Connect to mailbox?** is displayed. Select **Yes** to connect to your mailbox (network service) or **No** to view previously retrieved e-mail messages offline.

To connect to the mailbox afterwards, select **Options > Connect**.

When you create a new mailbox, the name you give to the mailbox replaces **Mailbox**. You can have up to six mailboxes.

When you are online, to end the data connection to the remote mailbox, select **Options > Disconnect**.

Retrieve e-mail messages from the mailbox

- 1 Select **Menu > Messaging > Mailbox > Options > Connect**.
- 2 Select **Options > Retrieve e-mail** and from the following options:

New – to retrieve all new e-mail messages to your device

Selected – to retrieve only the e-mail messages that have been marked

All – to retrieve all messages from the mailbox

- 3 After you have retrieved the e-mail messages, you can continue viewing them online. Select **Options > Disconnect** to close the connection and to view the e-mail messages offline.

- 4 To open an e-mail message, select it. If the e-mail message has not been retrieved and you are offline and select **Open**, you are asked if you want to retrieve this message from the mailbox.

To view e-mail attachments, indicated with , select **Options > Attachments**. You can retrieve, open, or save attachments in supported formats.

Delete e-mail messages

To delete an e-mail from the device while still retaining it in the remote mailbox, select **Options > Delete > Phone only**. The e-mail header stays in your device. To remove the header as well, delete the e-mail message from your remote mailbox first, then connect your device to the remote mailbox to update the status.

To delete an e-mail from the device and the remote mailbox, select **Options > Delete > Phone and server**.

To cancel deletion of an e-mail from both the device and server, scroll to an e-mail that has been marked to be deleted during the next connection, and select **Options > Restore**.

Outbox

The outbox folder is a temporary storage place for messages that are waiting to be sent.

To access the outbox folder, select **Menu > Messaging > Outbox**. Message statuses are as follows:

Sending – The device is sending the message.

Waiting or **Queued** – The device is waiting to send messages or e-mail.

Resend at ... – Sending failed. The device tries to send the message again after a time-out period. To retry sending the message immediately, select **Options > Send**.

Deferred – To set documents to be on hold while they are in the outbox folder, scroll to a message that is being sent, and select **Options > Defer sending**.

Failed – The maximum number of sending attempts has been reached.

Cell broadcast

You may be able to receive messages on various topics, such as weather or traffic conditions from your service provider (network service). To turn on the service, see **Cell broadcast** in "Cell broadcast settings", p. 46.

Select **Menu > Messaging > Options > Cell broadcast**.

A packet data connection may prevent cell broadcast reception.

Service command editor

To enter and send service commands (also known as USSD commands) such as activation commands for network services to your service provider, select **Menu > Messaging > Options > Service command**. To send the command, select **Options > Send**.

Messaging settings

Text message settings

Select **Menu > Messaging > Options > Settings > Text message** and from the following options:

Message centres – lists all the defined message centres.

Message centre in use – defines which message centre is used for delivering text messages and special message types such as business cards.

Character encoding > Full support – to select all characters in the message to be sent as viewed. If you select **Reduced support**, characters with accents and other marks may be converted to other characters.

Receive report (network service) – When set to **Yes**, the status of the sent message (**Pending, Failed, Delivered**) is shown in **Reports**.

Message validity – If the recipient of a message cannot be reached within the validity period, the message is removed from the message service centre. Note that the network must support this feature.

Message sent as – to define how the message is sent. The default is **Text**.

Preferred connection – You can send text messages using the normal GSM network or packet data if supported by your network.

Reply via same centre (network service) – If you select **Yes**, and the recipient replies to your message, the return message is sent using the same message service centre number. All networks do not provide this option.

Multimedia messaging settings

Select **Menu > Messaging > Options > Settings > Multimedia message** and from the following options:

Image size – Define the size of the image in a multimedia message. If you select **Original**, the image is not scaled.

MMS creation mode – If you select **Guided**, the device informs you if you try to send a message that may not be supported by the recipient. To set the device to prevent you from sending messages that are not supported, select **Restricted**. If you select **Free**, message creation is not restricted, but the recipient may not be able to view your message.

Access point in use – Select which access point is used as the preferred connection for multimedia messaging.

Multimedia retrieval – To receive multimedia messages only when you are in your home network, select **Auto in home netw..** To always receive multimedia messages, select **Always automatic**. To retrieve messages manually, select **Manual**. To not receive any multimedia messages or advertisements, select **Off**.

Allow anon. msgs. – To reject messages coming from an anonymous sender, select **No**.

Receive adverts – Define whether you want to allow reception of multimedia message advertisements.

Receive report – If you want the status of the sent message (**Pending, Failed, or Delivered**) to be shown in

Reports, select **Yes**. Receiving a delivery report of a multimedia message that has been sent to an e-mail address may not be possible.

Deny report sending > **Yes** – to deny sending delivery reports.

Message validity (network service) – If the recipient of a message cannot be reached within the validity period, the message is removed from the multimedia message centre.

E-mail settings

Mailbox settings

Select **Menu** > **Messaging** > **Options** > **Settings** > **E-mail** > **Mailboxes** and a mailbox.

If no mailbox settings have been defined before, you are asked if you want to define the settings.

Connection settings > **Incoming e-mail** and **Outgoing e-mail** – To define the correct settings, contact your e-mail service provider.

User settings

Select **User settings** and from the following settings:

My name – Enter the name to be displayed in outgoing e-mail.

Send message (network service) – To set when your e-mail messages are sent, select **Immediately** or **During next conn..**

Send copy to self – Select **Yes** to send a copy of the e-mail to the address defined in **My e-mail address**.

Include signature – Select **Yes** to attach a signature to your e-mail messages and to create or edit a signature text.

New e-mail alerts – To not receive alerts about new e-mail, select **Off**.

Retrieval settings

Select **Retrieval settings** and from the following settings:

E-mail to retrieve – To only retrieve headers, select **Headers only**. To limit how much data is retrieved, select **Size limit**, and enter the maximum amount of data per message in kilobytes. To retrieve messages and attachments, select **Msgs. & attachs.** **Size limit** and **Msgs. & attachs.** are only available with POP3 mailboxes.

Retrieval amount – To limit the number of messages to retrieve from the inbox of the remote mailbox, select **From Inbox** > **No. of e-mails** and enter the maximum number of messages to retrieve. You can also limit the number of messages to retrieve from other subscribed folders in **From folders** (only IMAP4 mailboxes).

IMAP4 folder path (only IMAP4 mailboxes) – Define the folder path for IMAP4 mailboxes.

Folder subscriptions (only IMAP4 mailboxes) – Select the mailbox folders you want to subscribe to. To subscribe to

or unsubscribe from a folder, scroll to it, and select **Options** > **Subscribe** or **Cancel subscription**.

Automatic retrieval

Select **Automatic retrieval** and from the following settings:

E-mail notifications – To automatically retrieve the headers to your device when you receive a notification of new e-mail in your remote mailbox, select **Auto-update** or **Only in home netw..**

E-mail retrieval – To have e-mail headers automatically retrieved at set intervals, select **Enabled**, or if you only want headers to be retrieved in your home network, select **Only in home netw..** Headers can be automatically retrieved for two mailboxes at most. You can set on which days, at what times, and how frequently the headers are retrieved in **Retrieval days**, **Retrieval hours**, and **Retrieval interval**.

E-mail notifications and **E-mail retrieval** cannot be active at the same time.

Service message settings

Select **Menu** > **Messaging** > **Options** > **Settings** > **Service message** and from the following settings:

Service messages – Allow or deny the reception of service messages.

Download messages – Download messages automatically or manually.

Cell broadcast settings

Check with your service provider whether cell broadcast (network service) is available and what the available topics and related topic numbers are.

Select **Menu** > **Messaging** > **Options** > **Settings** > **Cell broadcast** and from the following settings:

Reception – Select **On** or **Off**.

Language – Select in which languages cell broadcast messages are received.

Topic detection – To automatically save previously unknown topic numbers in received cell broadcast messages, select **On**.

Other settings

Select **Menu** > **Messaging** > **Options** > **Settings** > **Other** and from the following settings:

Save sent messages – Select to save a copy of every sent text message, multimedia message, or e-mail to the **Sent** folder.

Number of saved msgs. – Define how many sent messages are saved to the sent items folder at a time. When the limit is reached, the oldest message is deleted.

Memory in use – Select whether to save messages to the device memory or memory card.

Message reader

With **Message reader**, you can listen to received text, multimedia, and e-mail messages.

To listen to a message in **Inbox** or **Mailbox**, scroll to the message or mark the messages, and select **Options > Listen**. To skip to the next message, scroll down.



Tip: When **1 new message** or **New e-mail** is displayed in the standby mode, to listen to the received messages, press and hold the left selection key until **Message reader** starts.

Contacts

Manage contacts

Select **Menu > Contacts**.

To add a new contact, select **Options > New contact**. Fill in the fields you want, and select **Done**.

To edit a contact, scroll to it, and select **Options > Edit**.

To assign default numbers and addresses to a contact, select it, and select **Options > Defaults**. Scroll to the desired default option, and select **Assign**.

To copy names and numbers from a SIM card to your device, select **Options > SIM contacts > SIM directory**. Scroll to the names you want to copy, mark the desired names, and select **Options > Copy to Contacts**.

To copy a phone, fax, or pager number from contacts to your SIM card, scroll to the contact you want to copy, and select **Options > Copy > To SIM directory**.

To view the list of fixed dialing numbers, select **Options > SIM contacts > Fixed dial contacts**. This setting is only shown if supported by your SIM card.

When fixed dialling is activated, calls may be possible to the official emergency number programmed into your device.

Manage contact groups

Create a contact group so that you can send text or e-mail messages to several recipients at the same time.

1. Scroll to the right, and select **Options > New group**.
2. Enter a name for the group.
3. Select the group and **Options > Add members**.
4. Mark the contacts you want to add to the group, and select **OK**.

Add a ringing tone

You can set a ringing tone (and a video ringing tone) for each contact and group.

1. Select **Menu > Contacts**.
2. To add a ringing tone to a contact, select the contact, **Options > Ringing tone**, and the desired ringing tone.

To add a ringing tone to a group, scroll right to the groups list, and scroll to a contact group. Select **Options > Ringing tone** and the ringing tone for the group.

To remove the personal or group ringing tone, select **Default tone** as a ringing tone.

Assign speed dialing keys

You can assign a phone number to the speed dialing keys, 2 to 9. The 1 key is reserved for the call mailbox. Speed dialing has to be activated before using speed dialing. See **Speed dialling** in "Call", p. 79.

- 1 Select **Menu > Contacts** and a contact.
- 2 Scroll to a number, and select **Options > Assign speed dial**. Scroll to the desired speed dialing key, and select **Assign**. When you return to the contact information view,  next to the number indicates the assigned speed dial.

To call the contact by speed dialing, in the standby mode, press the speed dialing key and the call key, or press and hold the speed dialing key.

Gallery

Use **Gallery** to store and organize your images, video clips, music tracks, sound clips, track lists, streaming links, .ram files, and presentations.

Select **Menu > Gallery** and a folder.

To set an image as your wallpaper, select **Images** and the desired image. Select **Options > Use image > Set as wallpaper**. To assign the image to a contact, select **Assign to contact**.

To set a video as a video ringing tone, select **Video clips** and the desired video. Select **Options > Use video > Set as ringing tone**. To assign the video for a contact, select **Assign to contact**.

To copy files to device memory or to the memory card, scroll to the file or mark the files, and select **Options > Organise > Copy to phone mem.** or **Copy to memory card**.

To create image folders and move images to them, select **Images**, scroll to an image, select **Options > Organise > New folder**, and enter a name for the folder. Mark the images you want to move to the folder, and select **Options > Organise > Move to folder** and the folder.

Edit images

To edit images in **Gallery**, scroll to the image, and select **Options > Edit**.

To crop an image, select **Options > Apply effect > Crop**. To crop the image size manually, select **Manual** or a predefined aspect ratio from the list. If you select **Manual**, a cross appears in the upper left corner of the image. Scroll to select the area to crop, and select **Set**. Another cross appears in the lower right corner. Again select the area to be cropped. To adjust the first selected area, select **Back**. The selected areas form a rectangle, which forms the cropped image.

If you selected a predefined aspect ratio, select the upper left corner of the area to be cropped. To resize the highlighted area, use the scroll key. To freeze the selected area, press the scroll key. To move the area within the picture, scroll. To select the area to be cropped, press the scroll key.

To reduce red eye in an image, select **Options > Apply effect > Red eye reduction**. Move the cross onto the eye, and press the scroll key. A loop appears on the display. To

resize the loop to fit the size of the eye, scroll up, down, left, or right. To reduce the redness, press the scroll key.

Shortcuts in the image editor are as follows:

- To view an image in the full screen, press *. To return to the normal view, press * again.
- To rotate an image clockwise or counterclockwise, press **3** or **1**.
- To zoom in or out, press **5** or **0**.
- To move on a zoomed image, scroll up, down, left, or right.

Edit video clips

To edit video clips in **Gallery** and create custom video clips, scroll to a video clip, and select **Options > Video editor**.

In the video editor you can see two timelines: video clip timeline and sound clip timeline. The images, text, and transitions added to a video clip are shown on the video clip timeline. To switch between the timelines, scroll up or down.

Modify video

To modify the video, select from the following options:

Edit video clip:

Cut – trims the video clip in the cut video clip view.

Add colour effect – inserts a color effect on the video clip.

Use slow motion – slows the speed of the video clip.

Mute sound or **Unmute sound** – mutes or unmutes the original video clip sound.

Move – moves the video clip to the selected location.

Remove – removes the video clip from the video.

Duplicate – makes a copy of the selected video clip.

Edit text (shown only if you added text) – to move, remove, or duplicate text; change the color and style of the text; define how long it stays on the screen; and add effects to the text.

Edit image (shown only if you added an image) – to move, remove, or duplicate an image; define how long it stays on the screen; and set a background or a color effect to the image.

Edit sound clip (shown only if you have added a sound clip) – to cut or move the sound clip, to adjust its length, or to remove or duplicate the clip.

Edit transition – There are three types of transitions: at the start of a video, at the end of a video, and transitions between video clips. You can select start transition when the first transition of the video is active.

Insert – Select **Video clip**, **Image**, **Text**, **Sound clip**, or **New sound clip**.

Movie — Preview the movie in the full screen or as a thumbnail, save or send the movie, or cut the movie to a proper size for sending it in a multimedia message.

To take a snapshot of a video clip, in the cut video view, select **Options > Take snapshot**. In the thumbnail preview view, press the scroll key, and select **Take snapshot**.

To save your video, select **Options > Movie > Save**. To define the **Memory in use**, select **Options > Settings**.

To send the video, select **Send > Via multimedia, Via e-mail**, or **Via Bluetooth**. Contact your service provider for details of the maximum multimedia message size that you can send. If your video is too large to send in a multimedia message,  appears.

Transfer videos from PC

To transfer videos use a compatible USB cable or Bluetooth connectivity.

The requirements of the PC for video transfer are as follows:

- Microsoft Windows XP operating system (or later)
- Nokia PC Suite 6.82 or later
- Nokia Video Manager application (an add-on application to PC Suite)

If you connect the USB cable to transfer videos, use Nokia Video Manager in Nokia PC Suite, and select **PC Suite** as the connection mode.

To change the default USB connection mode, select **Menu > Settings > Connectivity > USB > USB mode**.

Nokia Video Manager in Nokia PC Suite is optimized for transcoding and transferring video files. For information about transferring video with Nokia Video Manager, see the Nokia Video Manager help.

Download files

Select **Menu > Gallery**, the folder for the file type you want to download, and the download function (for example, **Images > Downl. graphics**). The browser opens. Choose a bookmark for the site to download from.

Media

Camera

Your device has two cameras, a high resolution camera on the back cover (the main camera in landscape mode) and a lower resolution camera on the front (the secondary camera in portrait mode). You can use both cameras to take still pictures and record videos.

To use the main camera, open the main camera slide cover. To activate the camera, press the camera key.

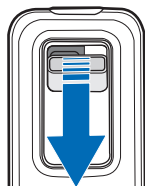

To zoom in or out, use the volume keys or scroll up or down. To capture an image, press the camera key. The image is saved to **Images** in **Gallery**, and the image is displayed. To return to the



viewfinder, select **Back**. To delete the photo, press the clear key.

To capture images sequentially, select **Options > Sequence mode > On**. In the sequence mode, the camera captures six images in short intervals and displays the images in a grid.

To use the panorama mode, select **Options > Panorama mode**. Press the capture key to capture a panorama image. The panorama preview is displayed. Turn slowly to right or left. You cannot change the direction. If the arrow on the display is red, you are turning too fast. To stop the panorama, press the capture key again. The panorama mode is available only in the main camera.

To turn the flash on or off, select **Options > Flash > On or Off**. If you select **Automatic**, the flash is used automatically when necessary. The flash is available only in the main camera.

Keep a safe distance when using the flash. Do not use the flash on people or animals at close range. Do not cover the flash while taking a picture.

In dim lighting, to use night mode, select **Options > Night mode > On**.

To use the self-timer, select **Options > Self-timer** and the time you want the camera to wait before capturing the image. Press the scroll key, and the timer starts.

To adjust the white balance or color tone, select **Options > Adjust > White balance** or **Colour tone**. The adjustment is available only in the main camera.

To record a video, select **Options > Video mode**, and press the scroll key to start recording.

Camera settings

Your device supports an image capture resolution of 1600 x 1200 pixels.

To change camera settings, select **Menu > Media > Camera > Options > Settings**.

Select **Image** and from the following settings:

Image quality, **Resolution (Camera 1)**, and **Resolution (Camera 2)** – The better the image quality and the higher the resolution, the more memory the image consumes.

Show captured image – To not display the image after capturing, select **No**.

Default image name – Change how the captured images are named.

Memory in use – Select whether you want to save your images in the device memory or on the memory card.

Select **Video** and from the following settings:

Length – If set to **Maximum**, the length of the recorded video is only restricted by the available memory. If set to **Short**, the recording time is optimized for MMS sending.

Resolution (Camera 1) and **Resolution (Camera 2)** – Select the video resolution.

Default video name – Select how the video clips are named.

Memory in use – Select whether you want to save your video clips in the device memory or on the memory card.

Music player

To open the music player, select **Menu > Media > Music player**.

Music library

Music library is a database of the available music tracks. To open the music library, in the music player main view, select **Options > Music library**.

To update the music library and search for music tracks in the device memory and on the memory card, select **Options > Update Music library**.

To play a specific album, select **Albums**, scroll to the album, and select **Options > Play**. To listen to specific tracks on the album, select **Albums** and an album, mark the tracks, and select **Options > Play**.

Track lists

To compile and save your own track list, select **Track lists > Options > New track list**. Select the memory in which to save the track list, and enter a name for the track list. Mark the desired tracks, and press the scroll key.

To listen to a track list, select **Track lists**, scroll to the track list, and select **Options > Play**.

You can add tracks to a saved track list from other views. For example, to add an album, select **Albums**, locate the album, scroll to it, and select **Options > Add to track list > Saved track list**. Select the track list to which to add the album.

Listen to music



Warning: Listen to music at a moderate level. Continuous exposure to high volume may damage your hearing. Do not hold the device near your ear when the loudspeaker is in use, because the volume may be extremely loud.

To start playing or pause playback, press the scroll key. To skip to the next or previous track, scroll down or up. To fast

forward or rewind, press and hold the scroll key down or up.

To see the currently playing track list, select **Options > Open 'Now playing'**.

To return to the standby mode and leave the music player in the background, press the end key.

To play the music tracks repeatedly, select **Options > Loop**. Select **All** to repeat all the currently playing tracks, **One** to repeat the currently playing track, or **Off** to not repeat tracks.

To play music in random order, select **Options > Random play > On**.

Audio settings

To adjust the tone of the sound and apply effects to the sound, select **Options > Audio settings**.

Equaliser

To enhance or diminish frequencies during music playback and modify how your music sounds, select **Options > Audio settings > Equaliser**.

To use a preset, scroll to it, and select **Options > Activate**.

Create a new preset

1. To create a new preset, select **Options > New preset**, and enter the preset name.

- To move between frequency bands, scroll left or right. To enhance or diminish sound in the frequency band, scroll up or down.
- Select **Back**.

RealPlayer

With RealPlayer, you can play media files such as video clips saved in the device memory or memory card, or stream media files over the air by opening a streaming link. To open RealPlayer, select **Menu > Media > RealPlayer**.

RealPlayer does not support all file formats or all the variations of file formats.

Play media files

To play a media file in RealPlayer, select **Options > Open** and from the following:

- Most recent clips** – to play media files that you have recently played
- Saved clip** – to play media files saved in the device or memory card

To stream content over the air, do the following:

- Select a streaming link saved in the gallery. A connection to the streaming server is established.
- Open a streaming link while browsing the web.

To stream live content, you must first configure your default access point. See "[Access points](#)", p. 82.

Many service providers require you to use an internet access point (IAP) for your default access point. Other service providers allow you to use a WAP access point. Contact your service provider for more information.

In RealPlayer, you can only open an `rtsp://` URL address. You cannot open an `http://` URL address; however, RealPlayer recognizes an `http` link to a `.ram` file since a `.ram` file is a text file containing an `rtsp` link.



Warning: Do not hold the device near your ear when the loudspeaker is in use, because the volume may be extremely loud.

Shortcuts during play

Scroll up to seek forward or down to seek back in the media file.

Press the volume keys to increase or decrease the sound volume.

Radio

You can use the Visual Radio application as a FM radio with automatic tuning and preset stations or with parallel visual information related to the radio program if you tune in to stations that offer Visual Radio service and your

network operator supports the service. The Visual Radio service uses packet data (network service).

Radio cannot be started when the device is in offline mode.

The FM radio depends on an antenna other than the wireless device antenna. A compatible headset or enhancement needs to be attached to the device for the FM radio to function properly.





Warning: Listen to music at a moderate level. Continuous exposure to high volume may damage your hearing. Do not hold the device near your ear when the loudspeaker is in use, because the volume may be extremely loud.

You can make a call or answer an incoming call while listening to the radio. The radio is muted when there is an active call.

To open Radio, select **Menu > Media > Radio**.



To turn the radio off, select **Exit**.

Tune and save a radio station

To start the station search when the radio is on, select  or . Searching stops when a station is found. To save the station, select **Options > Save station**. Select a location for the station. Enter the name of the station, and select **OK**.

Radio functions

To adjust the volume, press the volume keys.

Select  or  to scroll to the next or previous saved station. The buttons are inactive if there are no saved stations.

When using a compatible headset, press the headset key to scroll to the next saved radio station.

To save the current station, select **Options > Save station**, a preset position, and enter the station name.

To set the station frequency manually, select **Options > Manual tuning**.

To listen to the radio in the background and go to the standby mode, select **Options > Play in background**.

Station list

When the radio is on, select **Options > Stations**.

The station list is used for managing the saved radio stations.

Station setup

Scroll to a station in the station list, select it and **Edit** to change the station parameters.

View visual content

To check availability and costs, and to subscribe to the service, contact your service provider.

To view visual content of the current station, select .

If the visual service ID was not saved in the station list, you are asked for the visual service ID. Enter the visual service ID, and select **OK**. If you do not have the visual service ID, select **Retrieve** to access the station directory (network service).

To end the visual content feed but not the FM radio, select **Close**.

To set light settings and the power saver time-out, select **Options > Display settings**.

Visual Radio settings

When the radio is on, select **Options > Settings** and the following:

Start-up tone – to enable or disable the start-up tone

Auto-start service – to enable or disable the automatic display of visual content

Access point – to select the access point

Station directory

With the station directory (network service) you can select Visual Radio enabled or traditional radio stations from a list, grouped in folders.

To check availability and costs, and to subscribe to the service, contact your service provider.

Access the station directory from the visual content view

To retrieve the visual service ID and to start visual content for the currently tuned radio station, select  and **Retrieve**. After the connection to the station directory is established, select the nearest location to your current position from a list of folders.

The device compares the frequencies of the listed radio stations with the currently tuned in frequency. If a matching frequency is found, the visual service ID of the tuned radio station is displayed. Select **OK** to start viewing the visual content.

If there is more than one radio station with matching frequencies, the radio stations and their visual service ID are displayed in a list.

Select the desired radio station. The tuned radio station and the visual service ID are displayed. Select **OK** to start viewing the visual content.

Access the station directory from options

To access the station directory (network service) from the station list, select **Options > Station directory**.

After the connection to the station directory, you are requested to select the nearest location to your current position from a list of locations.

Radio stations that provide visual content are indicated with .

Select the desired radio station and from the following options:

Listen – to tune to the highlighted radio station. To confirm the frequency setting, select **Yes**.

Start visual service – to open the visual content of the selected radio station (if available)

Save – to save the details of the selected radio station to the station list

Details – to view channel information

Web

To browse web pages written in XHTML, WML, or HTML, select **Menu** > **Web**, or press and hold **0** in the standby mode.

Check the availability of services, pricing, and tariffs with your service provider. Service providers also give you instructions on how to use their services.



Important: Use only services that you trust and that offer adequate security and protection against harmful software.

Set up the phone for the browser service

Your device may configure the WAP or internet access point automatically based on your SIM card.

You can use **Settings wizard** to configure WAP or internet access point settings. See "[Settings wizard](#)", p. 84.

You may receive service settings in a configuration message from the service provider.

To define an access point manually, see "[Access points](#)", p. 82.







Make a connection

To access web pages, do the following:

- Select the home page () of your service provider.
- Select a bookmark from the bookmarks view.
- In the bookmarks view, enter the address of the web page, and select **Go to**.

View bookmarks

Bookmarks are indicated by the following icons:

-  The starting page defined for the default access point.
-  The automatic bookmarks folder contains bookmarks () that are collected automatically when you browse pages.
-  Any bookmark showing the title or internet address of the bookmark.
-  and  may be replaced with the icons of the website.

Add bookmarks manually

- 1 In the bookmarks view, select **Options** > **Bookmark manager** > **Add bookmark**.

- 2 Fill in the fields.
- 3 Select **Options** > **Save**.

Send bookmarks

Scroll to a bookmark or mark several bookmarks, select **Options** > **Tools** > **Send** and an option.

Connection security

If the security indicator  is displayed during a connection, the data transmission between the device and the internet gateway or server is encrypted.

The security icon does not indicate that the data transmission between the gateway and the content server (or place where the requested resource is stored) is secure. The service provider secures the data transmission between the gateway and the content server.

To view details about the connection, encryption status, and information about server authentication, select **Options** > **Tools** > **Page info**.

Security features may be required for some services, such as banking services. For such connections you need security certificates. For more information, contact your service provider. See also "[Certificate management](#)", p. 78.

Browse web pages

Copyright protections may prevent some images, music (including ringing tones), and other content from being copied, modified, transferred, or forwarded.



Important: Only install and use applications and other software from trusted sources, such as applications that are Symbian Signed or have passed the Java Verified™ testing.

Keys and commands for browsing

To open a link, make selections or check boxes, and press the scroll key.

To go to the previous page while browsing, select **Back**. If **Back** is not available, select **Options** > **Navigation options** > **History** to view a chronological list of the pages visited during a browsing session. To choose the desired page, scroll left or right, and select it. The history list is cleared each time a session is closed.

To save a bookmark while browsing, select **Options** > **Save as bookmark**.

To retrieve the latest content from the server, select **Options** > **Navigation options** > **Reload**.

To open the browser toolbar, scroll to an empty part of the page, and press the scroll key.

Keypad shortcuts while browsing

- 1 – Open your bookmarks.
- 2 – Search for keywords in the current page.
- 3 – Return to the previous page.
- 5 – List all open windows.
- 8 – Show the page overview of the current page. Press **8** again to zoom in and view the desired section of the page.
- 9 – Enter a new web address.
- 0 – Go to the start page.
- * or # – Zoom the page in or out.

Mini map

Mini map helps you navigate web pages that contain large amount of information. When **Mini map** is on in browser settings and you scroll through a large web page, **Mini map** opens and displays an overview of the web page you are browsing. To move in **Mini map**, scroll. When you stop scrolling, **Mini map** disappears and the area outlined in **Mini map** is displayed.

Page overview

With **Page overview**, you can move more quickly to the desired part of a web page. Page overview may not be available on all pages.

To show the page overview of the current page, press **8**. To find the desired spot on the page, scroll up or down. Press **8** again to zoom in and view the desired section of the page.

Web feeds and blogs

Web feeds are .xml files on web pages that are widely used to share the latest entry headlines or full text, for example, recent news in the form of news feeds. Blogs or weblogs are web diaries. Most of the web feeds use RSS and ATOM technologies.

The browser automatically detects if a web page contains web feeds. To subscribe to a web feed, select **Options > Subscribe** and a feed, or click on the link. To view the web feeds you have subscribed to, in the bookmarks view, select **Web feeds**.

To update a web feed, select it, and **Options > Refresh**.

To define how the web feeds are updated, select **Options > Settings > Web feeds**.

Saved pages

You can save pages and view them later offline.

To save a page while browsing, select **Options > Tools > Save page**.

To open the **Saved pages** view, in the bookmarks view, select **Saved pages**. To open a page, select it.

To start a connection to the browser service and retrieve the page again, select **Options > Navigation options > Reload**. The device stays online after you reload the page.

End a connection

To end the connection and view the browser page offline, select **Options > Tools > Disconnect**. To quit browsing, select **Options > Exit**.

Empty the cache

A cache is a memory location that is used to store data temporarily. If you have tried to access or have accessed confidential information requiring passwords, empty the cache after each use. The information or services you have accessed are stored in the cache. To empty the cache, select **Menu > Web > Options > Clear privacy data > Clear cache**.

To clear all privacy data, including the cache, cookies, form data, passwords, and browsing history, select **Menu > Web > Options > Clear privacy data > All**.

Browser settings

Select **Options > Settings** and from the following:

General

Access point – Select the default access point.

Homepage – Define the address of the desired homepage.

Mini map – Set on or off.

History list – Select whether a list of the pages you have visited during the current browsing session are displayed when you select **Back**.

Security warnings – Hide or show security notifications.

Java/Ecma Script – Enable or disable the use of scripts.

Page

Load content – Select what type of content is loaded automatically while browsing. If you select **Text only**, to load images during browsing, select **Options > Tools > Load images**.

Screen size – Choose how to use the display area for viewing pages.

Default encoding – When you select **Automatic**, the browser automatically tries to choose the correct character encoding.

Block pop-ups – Allow or block automatic opening of different pop-ups while browsing.

Automatic reload – Enable or disable automatic refresh of browser pages.

Font size – Select the font size.

Privacy

Auto. bookmarks – Select **On** if you want the bookmarks to be automatically saved in the **Auto. bookmarks** folder when you visit a page. When you select **Hide folder**, the bookmarks are still automatically added to the folder.

Form data saving – If you do not want the data you enter to different forms on a web page to be saved and used next time the page is entered, select **Off**.

Cookies – Enable or disable the receiving and sending of cookies (a means for content providers to identify users and their preferences for frequently used content).

Web feeds

Automatic updates – Define whether you want the web feeds to be updated automatically or not, and how often you want to update them. Setting the application to retrieve web feeds automatically may involve the transmission of large amounts of data through your service provider's network. Contact your service provider for information about data transmission charges.

Acc. point for auto-update – Select the desired access point for updating (only available when **Automatic updates** is on).

Download!

Download! (network service) is a mobile content shop available on your device. You may be able to download some content free of charge.

With **Download!** you can discover, preview, buy, download, and upgrade content, services, and applications. The items are categorized under catalogs and folders provided by different service providers. The available content depends on your service provider.

Select **Menu > Download!**.

Download! uses your network services to access the most up-to-date content. For information on additional items available through **Download!**, contact your service provider or the supplier or manufacturer of the item.

Organizer

Clock

Select **Menu** > **Organiser** > **Clock**.

Clock settings

To change the time or date, select **Options** > **Settings**. For more information about the settings, see "Date and time", p. 76.

Set an alarm

- 1 To set a new alarm, scroll right to **Alarm**, and select **Options** > **New alarm**.
- 2 Enter the alarm time, select whether and when the alarm is repeated, and select **Done**. When an alarm is active,  is shown.

To cancel an alarm, scroll to the alarm, and select **Options** > **Remove alarm**. To deactivate a repeated alarm, select **Options** > **Deactivate alarm**.

Turn off the alarm

Select **Stop** to turn off the alarm.

Select **Snooze** to stop the alarm for 5 minutes, after which it resumes.

World clock

To open the world clock view, scroll right to **World**. To add cities to the list, select **Options** > **Add city**.

To set your current city, scroll to a city, and select **Options** > **Set as current city**. The city is displayed in the clock main view, and the time in your device is changed according to the city selected. Check that the time is correct and matches your time zone.

Calendar

Select **Menu** > **Organiser** > **Calendar**.

In the calendar, you can keep track of your appointments, meetings, birthdays, anniversaries, and other events. You can also set a calendar alarm to remind you of upcoming events.

Create calendar entries

- 1 Select **Options** > **New entry** and an entry type.

- Anniversary** entries are repeated every year.
- Fill in the fields.
 - Repeat** – Press the scroll key to change the entry to be repeated. A repeating entry is indicated by  in the day view.
 - Repeat until** – Set an ending date for the repeated entry, for example, the last date of a weekly course you are taking. This option is shown only if you have selected to repeat the event.
 - Synchronisation > Private** – After synchronization the calendar entry can be seen only by you, and it is not shown to others even if they have online access to view the calendar. **Public** – The calendar entry is shown to others who have access to view your calendar online.
 - None** – The calendar entry is not copied when you synchronize your calendar.
 - To save the entry, select **Done**.

Calendar views

Press **#** in the month, week, or day views to automatically highlight today's date.

To create a meeting entry, press any number key (0–9) in any calendar view.

To go to a certain date, select **Options > Go to date**. Write the date, and select **OK**.

To-do

Select **Options > To-do view**.

In the **To-do view**, you can keep a list of tasks that you need to do.

Create a to-do note

- To start to write a to-do note, press any number key (0–9).
- Write the task in the **Subject** field. Set a due date and a priority for the task.
- To save the to-do note, select **Done**.

Notes

Select **Menu > Organiser > Notes**.

To write a new note, start writing. To save the note, select **Done**.

You can save plain text files (.txt format) you receive to **Notes**.

Converter

Select **Menu > Organiser > Converter**.

In the converter, you can convert measurement parameters from one unit to another, for example, length (yards to metres).

The converter has limited accuracy and rounding errors may occur.

Convert units

To convert currency, you must first set the exchange rate. See "[Set a base currency and exchange rates](#)", p. 68.

- 1 Select **Type**, the type of measurement to convert, and **OK**.
- 2 Select the first unit field, the unit **from** which you want to convert, and **OK**.
- 3 Select the next unit field and the unit **to** which you want to convert.
- 4 In the first amount field, enter the value to be converted. The other amount field changes automatically to show the converted value.

Press **#** to add a decimal and press ***** for the **+**, **-** (for temperature), and **E** (exponent) symbols.

The conversion order changes if you write a value in the second amount field. The result is shown in the first amount field.

Set a base currency and exchange rates

Before you can convert currency, you need to choose a base currency (usually your domestic currency) and add exchange rates.

The rate of the base currency is always 1. The base currency determines the conversion rates of the other currencies.

- 1 Select **Currency** as the measurement type, then **Options > Currency rates**.
- 2 To change the base currency, scroll to the currency (usually your domestic currency), and select **Options > Set as base currency**.
- 3 Add exchange rates, scroll to the currency, and enter a new rate, that is, how many units of the currency equal one unit of the base currency you selected.
- 4 After you insert all the required exchange rates, you can convert currency.

When you change base currency, you must enter new exchange rates because all previously set exchange rates are cleared.

Applications

GPS data

To start the GPS data application, select **Menu** > **Applications** > **GPS data**.

Navigation

To use route guidance, select **Navigation**.

Route guidance shows the straightest route and the shortest distance to the destination. Any obstacles, such as buildings and natural obstacles, are ignored. Differences in altitude are not taken into account when calculating the distance. Route guidance is active only when you move.

To set your trip destination, select **Options** > **Set destination** and a landmark as the destination, or enter the latitude and longitude coordinates. Select **Stop navigation** to clear the set destination.

To view the position information of your current location, select **Position**.

Position

To save your current location as a landmark, select **Options** > **Save position**.

Trip distance

Select **Trip distance** > **Options** > **Start** to activate trip distance calculation and **Stop** to deactivate it. The calculated values remain on the display.

Select **Reset** to set the trip distance, time, average and maximum speeds to zero and to start a new calculation.

Select **Restart** to set also the odometer and total time to zero.

The trip meter has limited accuracy, and rounding errors may occur. Accuracy can also be affected by availability and quality of GPS signals.

Position requests

You may receive a request from a network service to receive your position information. Service providers may offer information about local topics, such as weather or traffic conditions, based upon the location of your device.

When you receive a position request, a message is displayed showing the service that is making the request. To allow your position information to be sent, select **Accept**; to deny the request, select **Reject**.

Landmarks

With landmarks you can save the position information of specific locations to your device. You can use your saved landmarks in compatible applications, such as the Navigator application.

To create a new landmark, select **Menu > Applications > Landmarks > Options > New landmark**. To make a positioning request for the coordinates of your current location, select **Current position**. To enter the position information manually, select **Enter manually**.

To add a landmark to preset categories, select the landmark, and **Options > Add to category**. Select the categories to which you want to add the landmark.

To send one or several landmarks to a compatible device, select **Options > Send**. Your received landmarks are placed in **Inbox** in **Messaging**.

Adobe Reader

Use **Adobe Reader** to view portable document format (.pdf) documents. To open the application, select **Menu > Applications > Adobe PDF**.

Open a .pdf file

To open a recently viewed document, select it. To open a document that is not listed in the main view, select **Options > Browse for file** the memory and folder wherein the file resides and the file.

View a document

To move around within a page, scroll. To move to the next page, scroll down at the bottom of the page.

To zoom in or out, select **Options > Zoom > In** or **Out**.

To find text, select **Options > Find > Text**, and enter the text you want to find. To find the next occurrence, select **Options > Find > Next**.

To rotate the document, select **Options > View > Rotate left** or **Rotate right**.

To save a copy of the document, select **Options > Save**, and specify where to save it.

Settings

Select **Options > Settings** and from the following settings: **Default zoom %** – to set the default zoom when opening a .pdf file for viewing

View mode > Full screen – to open documents in full screen mode

Save settings on exit > Yes – to save the settings as default when you exit **Adobe Reader**

Quickoffice

To use the Quickoffice applications, select **Menu > Applications > Quickoffice**.

To view a list of Word, Excel, and PowerPoint documents, scroll right or left to the Quickword, Quicksheet, or Quickpoint view. For example, available Microsoft Word documents are listed in the Quickword view.

To open a file in its respective application, select it. To sort files, select **Options > Sort by** and an option.

Quickword

With Quickword, you can view native Microsoft Word documents on the display of your device. Quickword supports colors, bold, italics, and underline.

Quickword supports the viewing of documents saved in .doc format in Microsoft Word 97, 2000, XP, and 2003. Not all variations or features of the mentioned file formats are supported.

View Word documents

To move in the document, scroll.

To search the document for text, select **Options > Search options > Find**.

Quicksheet

With Quicksheet, you can read Microsoft Excel files on the display of your device.

Quicksheet supports the viewing of spreadsheet files saved in .xls format in Microsoft Excel 97, 2000, XP, and 2003. Not all variations or features of the mentioned file formats are supported.

View spreadsheets

To move around in the spreadsheet, scroll.

To switch between worksheets, select **Options > Worksheet**.

To search the spreadsheet for a text within a value or formula, select **Options > Search options > Find**.

To change how the spreadsheet is displayed, select **Options** and from the following:

Pan – to navigate within the current worksheet by blocks. Scroll to the desired block, and select it.

Zoom – to zoom in or out

Freeze panes – to keep the rows and columns above and to the left of the selected cell visible

Resize – to adjust the size of columns or rows

Quickpoint

With Quickpoint, you can view Microsoft PowerPoint presentations on the display of your device.

Quickpoint supports the viewing of presentations created in .ppt format in Microsoft PowerPoint 2000, XP, and 2003. Not all variations or features of the mentioned file formats are supported.

View presentations

To move between the slide, outline, and the notes view, scroll left or right.

To move to the next or previous slide in the presentation, scroll down or up.

To view the presentation in full screen, select **Options > Full screen**.

To expand items in the presentation outline in the outline view, select **Options > Outline > Expand**.

Quickmanager

With Quickmanager, you can download software, including updates, upgrades, and other useful applications. You can pay for the downloads by phone bill or credit card.

To open Quickmanager, select **Menu > Applications > Quickoffice**, and scroll right to the Quickmanager view.

More information

If you experience problems with Quickword, Quicksheet, or Quickpoint, visit www.quickoffice.com for more information. Support is also available by sending an e-mail to supportS60@quickoffice.com.

Settings

Profiles

Select **Menu** > **Settings** > **Profiles**.

In **Profiles**, you can adjust and personalize the device tones for different events, environments, or caller groups. You can see the currently selected profile at the top of the display in the standby mode. If the **General** profile is in use, only the current date is shown.

To activate the profile, select the profile and **Activate**.



Tip: To quickly change to **Silent** from any other profile, in the standby mode, press and hold #.

To personalize a profile, select the profile, **Personalise**, and from the following options:

Ringtone – To set the ringing tone (also a video ringing tone) for voice calls, choose a ringing tone from the list. Press any key to stop the sound. You can also change ringing tones in contacts. See "[Add a ringing tone](#)", p. 48.

Video call tone – Select the ringing tone for video calls.

Say caller's name – Select **On** to have the device say the caller's name when the phone is ringing.

Ringtone type – When **Ascending** is selected, the ringing volume starts from level one and increases level by level to the set volume level.

Ringtone volume – Set the volume level for the ringing and message alert tones.

Message alert tone – Set the alert tone for text and multimedia messages.

E-mail alert tone – Set the alert tone for e-mail messages.

Vibrating alert – Set the device to vibrate to alert for incoming calls and messages.

Keypad tones – Set the volume level for keypad tones.

Warning tones – Activate or deactivate warning tones.

Alert for – Set the device to ring only upon calls from phone numbers that belong to a selected contact group. Phone calls coming from people outside the selected group have a silent alert.

Profile name – Name the profile. This setting is not shown for the **General** and **Offline** profiles.

When using **Offline**, the device is not connected to the cellular network. If no SIM card is installed, to use some functions of the device, start the device in **Offline**.



Important: In the offline profile you cannot make or receive any calls, or use other features that require cellular network coverage. Calls may still be possible to the official emergency number programmed into your device. To make calls, you must first activate the phone function by changing profiles. If the device has been locked, enter the lock code.

Themes

To change the look of your device's display, activate a theme. A theme can include the standby mode wallpaper and power saver. You can edit a theme to personalize your device further.

Select **Menu > Settings > Themes**. To see a list of the available themes, select **General**. The active theme is indicated by a check mark.

To preview a theme, scroll to the theme, and select **Options > Preview**. To activate the previewed theme, select **Set**.

In **Themes**, you can also set the menu view type, set a custom wallpaper, and personalize the power saver and the cover display.

3-D tones

With **3-D tones** you can apply three-dimensional sound effects to ringing tones. Not all ringing tones support 3-D effects. To edit 3-D tone settings, select **Menu > Settings > 3-D tones**.

To enable the 3-D effects, select **3-D tones > On**. To change the ringing tone, select **Ringing tone** and the desired ringing tone.

To change the 3-D effect that is applied to the ringing tone, select **Sound trajectory** and the desired effect. To modify the effect, select **Trajectory speed**, **Doppler effect**, or **Reverberation**. **Doppler effect** is not available for all sound trajectories.

To listen to the ringing tone with the 3-D effect, select **Options > Play tone**

If you enable the 3-D tones but do not select any 3-D effect, stereo widening is applied to the ringing tone.

Voice commands

To select the device functions to activate with a voice command, select **Menu > Settings > Voice comm..** The voice commands for changing profiles are in the **Profiles** folder.

To activate a new voice command for an application, select **Options > New application** and the application. To play the activated voice command, select **Options > Playback**.

To use voice commands, see "Voice dialing", p. 24.

Phone settings

General

Select **Menu > Settings > Phone sett. > General > Personalisation, Date and time, Slide handling, Enhancement, Security, Factory settings, Positioning, or My own key**.

Personalisation

Select **Display, Standby mode, Tones, Language, Themes, or Voice comms..**

Display

Light sensor – to adjust the light sensor that observes the lighting conditions and adjusts the brightness of the display

Font size – to select the font size used in lists and editors

Power saver time-out – to set the time-out period after which the power saver is activated

Welcome note / logo – to set the welcome note or logo which is displayed briefly each time you switch on the device.

Light time-out – to set the time-out for the display light

Standby mode

Active standby – to enable or disable active standby. See "Active standby", p. 19.

Active standby apps. – to select the application shortcuts to appear in the active standby. This setting is available only if **Active standby** is set to **On**.

Shortcuts – to assign shortcuts for the right and left selection keys, scrolling in different directions or pressing the scroll key in the standby mode. The scroll key shortcuts are not available if **Active standby** is **On**.

Operator logo – this setting is visible only if you have received and saved an operator logo. You can select whether the operator logo is shown.

Tones

Change the tones of the clock, calendar and currently active profile. See "Profiles", p. 73.

Language

Phone language – to change the language for the display texts in your device. This change may also affect the format used for date and time and the separators used, for example, in calculations. If you select **Automatic**, the

device selects the language according to the information on your SIM card. After you have changed the display text language, the device restarts.

Writing language – to change the writing language of your device. Changing the language affects the characters and special characters available when writing text and the predictive text dictionary used.

Predictive text – to set predictive text input **On** or **Off** for all editors in the device. Select a language for entering predictive text from the list.

Themes

Apply themes. See "[Themes](#)", p. 74.

Voice commands

Edit voice command and voice dialing settings. See "[Voice commands](#)", p. 74.

Date and time

Time and **Date** – to set the time and date.

Time zone – to set the time zone of your location. If you set **Network operator time** > **Auto-update**, the local time is shown.

Date format – to select the format to display dates.

Date separator – to select the date separator.

Time format – to select between 24-hour and 12-hour time format.

Time separator – to select the time separator.

Clock type – to select whether the analog or digital clock is shown in the standby mode. See "[Clock](#)", p. 66.

Clock alarm tone – to select the alarm clock tone.

Workdays – to specify days for alarms repeated only on workdays.

Network operator time (network service) – to allow the network to update time, date, and time zone information to your device. If you select **Auto-update**, all active connections are disconnected. Check any alarms as these may be affected.

Slide handling

Opening the slide – to select whether incoming calls are answered when opening the slide, select **Answer incoming call** or **Call not answered**.

Closing the slide – to select whether active calls are ended when closing the slide, select **End active call** or **Continue active call**.

Keypad activation – to select whether the keypad is locked when closing the slide, select **On when closing slide** or **Off when closing slide**. To receive a query every time when closing the slide, select **Always ask**.

Enhancement

To change settings of an enhancement, in the **Enhancement sett.** view, scroll to an enhancement, such as **Headset**, select **Options > Open** and from the following options:

Default profile – to select the profile you want to activate each time you connect the enhancement to your device

Automatic answer – to set the device to answer an incoming call automatically after 5 seconds when this enhancement is connected to your device. If the **Ringling type** is set to **Beep once** or **Silent**, automatic answer cannot be used, and you must answer the call manually.

Lights – to set the device lights continuously on while using the enhancement, select **On**.

Security

Select **Phone and SIM card**, **Certificate management**, or **Security module**.

Phone and SIM card

You can change the following codes: lock code, PIN or UPIN code, and PIN2 code. These codes can only include the numbers from 0 to 9.

Avoid using access codes similar to emergency numbers to prevent accidental dialing of the emergency number.

Code in use – to select the active code, **PIN** or **UPIN**, for the active USIM. This is shown only if the active USIM supports UPIN, and the UPIN is not rejected.

PIN code request or **UPIN code request** – to set the device to request the code each time the device is switched on. Some SIM cards may not allow the PIN code request to be turned **Off**. If you select **Code in use > UPIN**, **UPIN code request** is shown instead.

PIN code or **UPIN code**, **PIN2 code**, and **Lock code** – to change the codes

Keypad autolock period > User defined – to automatically lock the keypad after a defined period of inactivity

Phone autolock period – to set a time-out after which the device is automatically locked. To use the device again, you need to enter the correct lock code. To turn off the autolock period, select **None**.

Lock if SIM card changed – to set the device to prompt for the lock code when an unknown, new SIM card is inserted into your device. The device keeps a list of SIM cards that are recognized as the owner cards.

Closed user group (network service) – to specify a group of people whom you can call and who can call you. For more information, contact your service provider. To activate the default group agreed on with the service

provider, select **Default**. If you want to use another group (you need to know the group index number), select **On**.

When calls are limited to closed user groups, calls may be possible to the official emergency number programmed into your device.

Confirm SIM services (network service) – to set the device to display confirmation messages when you use a SIM card service

Certificate management

A list of authority certificates that have been stored in your device is displayed in **Certificate management**. To see a list of personal certificates if available, scroll right.

Digital certificates should be used if you want to connect to an online bank or another site or remote server for actions that involve transferring confidential information. They should also be used if you want to reduce the risk of viruses or other malicious software and be sure of the authenticity of software when downloading and installing software.

When security features that restrict calls are in use (such as call barring, closed user group, and fixed dialling), calls may be possible to the official emergency number programmed into your device.



Important: Even if the use of certificates makes the risks involved in remote connections and software installation considerably smaller, they must be used correctly in order to benefit from increased security. The existence of a certificate does not offer any protection by itself; the certificate manager must contain correct, authentic, or trusted certificates for increased security to be available. Certificates have a restricted lifetime. If "Expired certificate" or "Certificate not valid yet" is shown even if the certificate should be valid, check that the current date and time in your device are correct.

Before changing any certificate settings, you must make sure that you really trust the owner of the certificate and that the certificate really belongs to the listed owner.

View certificate details and check authenticity

You can only be sure of the correct identity of a server when the signature and the period of validity of a server certificate have been checked.

The device notifies you if the identity of the server is not authentic or if you do not have the correct security certificate in your device.

To check certificate details, scroll to a certificate, and select **Options** > **Certificate details**. While opening the

certificate details, the device checks the validity of the certificate and one of the following notes may appear:

Expired certificate – The validity period has ended for the selected certificate.

Certificate not valid yet – The validity period has not yet begun for the selected certificate.

Certificate corrupted – The certificate cannot be used. Contact the certificate issuer.

Certificate not trusted – You have not set any application to use the certificate.

Change the trust settings

Before changing any certificate settings, you must make sure that you really trust the owner of the certificate and that the certificate really belongs to the listed owner.

Scroll to an authority certificate, and select **Options** > **Trust settings**. Depending on the certificate, a list of the applications that can use the selected certificate is shown.

Security module

View or edit security modules.

Factory settings

Reset some of the settings to their original values. You need the lock code. See "[Lock code](#)", in "[Access codes](#)", p. 21.

My own key

My own key – to configure pressing the my own key to open a specific application. See "[My own key](#)", p. 22.

Positioning

With the positioning service you can receive information from service providers about local issues such as weather and traffic conditions, based on the location of your device (network service).

To enable a positioning method, select **Positioning methods**, scroll to the positioning method, and select **Options** > **Enable**. To stop using it, select **Options** > **Disable**.

To define the positioning server access point, select **Positioning server** > **Access point** and the desired access point. Then select **Server address**, and enter the domain name or URL address of the server.

Phone

Select **Menu** > **Settings** > **Phone sett.** > **Phone** and **Call**, **Call divert**, **Call barring**, or **Network**.

Call

Send my caller ID (network service) – to set your phone number to be displayed (**Yes**) or hidden (**No**) from the person whom you are calling. The value may be set by your

service provider when you subscribe to the service (**Set by network**).

Call waiting (network service) — to set the network to notify you of a new incoming call while you have a call in progress. To request the network to activate call waiting, select **Activate**. To request the network to deactivate call waiting, select **Cancel**. To check whether the function is active, select **Check status**.

Reject call with SMS — to enable rejecting phone calls with a text message. See "Answer or reject a call", p. 25.

Message text — to enter a text to be sent when you reject a call with a text message

Image in video call — to select a still image to be shown instead of the video when you deny video sending in a video call

Automatic redial — to set the device to make a maximum of 10 attempts to connect the call after an unsuccessful call attempt. Press the end key to stop automatic redialing.

Summary after call — to set the device to briefly display the approximate duration of the last call

Show call duration — to set the device to display the call duration during a call

Speed dialling > On — to set the device to dial the numbers assigned to the speed dialling keys, **2** to **9**, by pressing and holding the corresponding number key

Anykey answer > On — to answer an incoming call by briefly pressing any key, except the left and right selection keys, volume keys, my own key, Navigator key and the end key

Line in use (network service) — shown only if the SIM card supports two subscriber numbers, that is, two phone lines. Select which phone line (**Line 1** or **Line 2**) you want to use for making calls and sending short messages.

Calls on both lines can be answered irrespective of the selected line. You cannot make calls if you select **Line 2** and have not subscribed to this network service. To prevent line selection, select **Line change > Disable** if supported by your SIM card. To change this setting, you need the PIN2 code.

Call divert

Call divert is a network service.

- 1 Select which calls you want to divert: **Voice calls**, **Data and video calls**, or **Fax calls**.
- 2 Select the desired option. For example, to divert voice calls when your number is busy or when you reject an incoming call, select **If busy**.
- 3 To set the divert option on or off, select **Activate** or **Cancel**. To check whether the option is activated, select **Check status**. Several divert options can be active at the same time.

Call barring and call diverting cannot be active at the same time.

Call barring

Call barring (network service) allows you to restrict the calls that you make and receive with your device. To change the settings, you need the barring password from your service provider.

Scroll to the desired barring option, and to request the network to set call restriction on, select **Options > Activate**. To set the selected call restriction off, select **Cancel**. To check whether the calls are barred, select **Check status**. To change the barring password, select **Edit barring password**. To cancel all active call barrings, select **Cancel all barrings**.

Call barring and call diverting cannot be active at the same time.

When calls are barred, calls may be possible to certain official emergency numbers.

Network

Network mode – To select which network to use (shown only if supported by the service provider). If you select **Dual mode**, the device uses the GSM or UMTS network automatically, according to the network parameters and the roaming agreements between the network operators.

Operator selection – To set the device to search for and select automatically one of the available networks, select **Automatic**. To select the desired network manually from a list of networks, select **Manual**. If the connection to the manually selected network is lost, the device sounds an error tone and asks you to select a network again. The selected network must have a roaming agreement with your home network, that is, the operator whose SIM card is in your device.

Cell info display (network service) – To set the device to indicate when it is used in a cellular network based on microcellular network (MCN) technology and to activate cell info reception, select **On**.

Connection

Select **Menu > Settings > Phone sett. > Connection > Bluetooth, USB, Access points, Packet data, Data call, SIP settings, Configurations, or APN control**.

Bluetooth

Switch Bluetooth on or off, and edit Bluetooth settings. See "[Bluetooth connection](#)", p. 87.

USB

Edit USB settings. See "[USB data cable](#)", p. 89.

Access points

To establish a data connection, an access point is required. You can define different kinds of access points:

- MMS access point to send and receive multimedia messages
- WAP access point to view web pages
- Internet access point (IAP) (for example, to send and receive e-mail)

Check which kind of access point you need with your service provider for the service you wish to access. For availability and subscription to data connection services, contact your service provider.

You may receive access point settings in a message from your service provider, or you may have preset access point settings in your device.

To create a new access point or edit an existing access point, select **Options > New access point** or **Edit**. To create a new access point using the settings of an existing access point, scroll to an access point, and select **Options > Duplicate access point**.

Depending on the connection type selected in **Data bearer**, only certain settings are available. Fill in all fields marked with **Must be defined** or with an asterisk.

Contact your service provider for the following settings: **Data bearer**, **Access point name** (for packet data only), **Dial-up number** (for data call only), **User name**, **Password**,

Authentication, **Homepage**, **Data call type** (for data call only), and **Maximum data speed** (for data call only).

Connection name – Enter a descriptive name for the connection.

Prompt password – If you must enter a new password every time you log onto a server, or if you do not want to save your password to the device, select **Yes**.

If necessary, to define the internet protocol (IP) version, phone IP address, domain name system (DNS) servers, proxy server, and advanced data call settings, such as callback, PPP compression, login script, and modem initialization string, select **Options > Advanced settings**. Contact your service provider for the correct settings.

Packet data

The packet data settings affect all access points using a packet data connection.

Packet data connection – If you select **When available** and you are in a network that supports packet data, the device registers to the packet data network and short messages are sent using a packet data connection. If you select **When needed**, the device uses a packet data connection only if you start an application or function that needs it. The packet data connection can be closed when it is not needed by any application.

If there are no packet data services available and you have chosen **When available**, the device periodically tries to establish a packet data connection.

Access point – The access point name is needed when you want to use your device as a modem with your computer.

High speed packet access – Enable or disable the use of HSDPA (network service) in UMTS networks.

When HSDPA support is activated, downloading data such as messages, e-mail, and browser pages through the cellular network may be faster.

Data call

The data call settings affect all access points that use a GSM data call.

Online time – to set the data call to disconnect automatically after a time-out if there is no activity. To enter a time-out, select **User defined**, and enter the time in minutes. If you select **Unlimited**, the data call is not disconnected automatically.

SIP settings

View and edit session initiation protocol (SIP) profiles.

Configurations

Certain functions, such as web browsing and multimedia messaging, may require configuration settings. You may

receive the settings from your service provider. See "Configuration settings", p. 17.

To delete a configuration, scroll to the configuration, and select **Options > Delete**.

Access point name control

With the access point name control service, you can restrict the use of packet data access points. This setting is only available if a USIM card is inserted and the USIM card supports the service. To change the settings, you need the PIN2 code.

Applications

To view and edit settings of applications installed to your device, select **Menu > Settings > Phone sett. > Applications**.

Speed dial

To assign phone numbers to the speed dialing keys, select **Menu > Settings > Speed dial**, scroll to the speed dialing key, and select **Options > Assign**. Select the contact and the number for the speed dial.

To view the number assigned to a speed-dialing key, scroll to the speed dialing key, and select **Options > View**

number. To change or remove the number, select **Change** or **Remove**.

Speech

To select the default language and voice used for reading messages and adjust the voice properties, such as rate and volume, select **Menu > Settings > Speech**.

To view details of a voice, scroll right, scroll to the voice, and select **Options > Voice details**. To test a voice, scroll to the voice, and select **Options > Play voice**.

Settings wizard

The settings wizard configures your device for operator (MMS, GPRS, and internet) and e-mail settings based on your service provider. Configuring other settings may also be possible.

To use these services, you may have to contact your service provider to activate a data connection or other services.

Select **Menu > Settings > Sett. wizard**.

Call mailbox

To define or change the call mailbox number, select **Menu > Settings > Call mailbox > Options > Define number** or

Change number, and enter the number. Call mailbox is a network service. Contact your service provider for the call mailbox number.

Instant messaging

Instant messaging (IM) allows you to converse with others and join discussion forums (IM groups) with specific topics (network service).

Check the availability of IM services, pricing, and tariffs with your service provider. Service providers also provide instructions on how to use their services.

Connect to an IM server

Select **Menu > Settings > IM**.

- 1 To log in, select **Options > Log in**.
- 2 Enter your user ID and password.

To log out, select **Options > Log out**.

IM settings

Select **Menu > Settings > IM > Options > Settings**.

To edit the IM application settings, select **Preferences**. To set who is allowed to see when you are online, select **Show my availability**. To set who is allowed to send you

messages or invitations, select **Allow messages from** or **Allow invitations from**.

To edit IM server connection settings, select **Servers**, scroll to the server, and select **Options > Edit**. Contact your service provider for the settings. To define new server settings, select **Options > New server**.

To choose the default server, select **Default server** and the server.

To be automatically connected to the IM server during the days and times you define, select **IM login type > Automatic**. To only be automatically connected while in your home network, select **Auto in home netw..** To be automatically connected when you start the IM application, select **On app. start-up**. To connect manually, select **Manual**.

To set days and times when to establish a connection automatically, select **Automatic login days** and **Automatic login hrs..**

Join and leave an IM group

Select **Menu > Settings > IM > IM groups**.

IM groups are only available if supported by the service provider.

To join an IM group, select it, and enter your screen name. To join an IM group not on the list, but whose group ID you

know, select **Options > Join new group**, and enter the group ID.

To leave the IM group, select **Options > Leave IM group**.

Search for IM groups and users

To search for groups, select **Menu > Settings > IM > IM groups > Options > Search**. You can search IM groups by **Group name**, **Topic**, or **Members** (user ID). To join or save a group that is found in the search, scroll to it, and select **Options > Join** or **Save**.

To search for new contacts, select **IM contacts > Options > New IM contact > Search from server**. To start a conversation with a new user, scroll to the user, and select **Options > Open conversation**. To save the new contact, select **Add to IM contacts**.

Chat in an IM group

Select **Menu > Settings > IM > IM groups**.

After you join an IM group, you can view the messages that are exchanged in the group, and send your own messages.

To send a message, write the message, and press the scroll key.

To send a private message to a member (if allowed in the group), select **Options > Send private message**, select the recipient, write the message, and press the scroll key.

To reply to a private message sent to you, scroll to the message, and select **Options > Reply**.

To invite IM contacts who are online to join the IM group (if allowed in the group), select **Options > Send invitation**, select the contacts you want to invite, write the invitation message, and select **Send**.

Start and view individual conversations

Select **Menu > Settings > IM > Conversations**.

This shows a list of the IM users with whom you have an ongoing conversation.

 next to a user indicates that you have received a new message from that user.

To view an ongoing conversation, select the user. To send a message, write your message, and press the scroll key. To return to the conversations list without closing the conversation, select **Back**.

To start a new conversation, select **Options > New conversation > Select from contacts** and from a list of your saved IM contacts that are currently online; or select **Enter user ID** to enter the user ID.



To close the conversation, select **Options > End conversation**.

To save a user to your IM contacts, scroll to the user, and select **Options > Add to IM contacts**.

To block messages from a user, scroll to the user, and select **Options > Blocking options > Add to blocked list**.

IM contacts

Select **Menu > Settings > IM > IM contacts**.

You can see a list of your saved IM contacts.  indicates contacts that are currently online,  indicates contacts that are busy, and  indicates contacts that are offline.

To create a new contact manually, select **Options > New IM contact > Enter manually**. Fill in the **User ID** and **Nickname** fields, and select **Done**.

To start or continue a conversation with a contact, scroll to the contact, and select **Options > Open conversation**.

Create a new IM group

Select **Menu > Settings > IM > IM groups > Options > Create new group**. Enter the settings for the group.

Restrict access to an IM group

To create a closed IM group, create a group members list. Only the users on the list are allowed to join the group. Select the **IM groups** view, scroll to the group, and select **Options > Group > Settings > Group members > Selected only**.

Connectivity

PC Suite

With PC Suite you can synchronize contacts, calendar and to-do notes and notes between your device and a compatible PC, or a remote internet server (network service).

You may find more information about PC Suite and the download link in the support area on the Nokia website, www.nokia-asia.com/6110/support.

Bluetooth connection

Bluetooth technology enables wireless connections between electronic devices within a maximum range of 10 meters (33 feet). A Bluetooth connection can be used to send images, videos, texts, business cards, calendar notes, or to connect wirelessly to compatible devices using Bluetooth technology, such as computers.

This device is compliant with Bluetooth Specification 2.0 supporting the following profiles: Dial Up Networking, Serial Port, File Transfer, Handsfree, Headset, Basic Imaging, SIM Access, Generic Access and Advanced Audio Distribution. To ensure interoperability between other

devices supporting Bluetooth technology, use Nokia approved enhancements for this model. Check with the manufacturers of other devices to determine their compatibility with this device.

Features using Bluetooth technology increase the demand on battery power and reduce the battery life.

Bluetooth connection settings

Select **Menu > Settings > Connectivity > Bluetooth**.

Bluetooth – to switch Bluetooth on or off

My phone's visibility > Shown to all – to allow your device to be found by other Bluetooth devices at all times. To allow your device to be found for a defined time period, select **Define period**. For security reasons it is advisable to use the **Hidden** setting whenever possible.

My phone's name – to define a name for your device.

Remote SIM mode > On – to enable the usage of the SIM card of the device by another device (for example, a car kit) by Bluetooth technology (SIM access profile)

When the wireless device is in the remote SIM mode, you can only use a compatible connected enhancement, such as a car kit, to make or receive calls. Your wireless device

will not make any calls, except to the emergency numbers programmed into your device, while in this mode. To make calls from your device, you must first leave the remote SIM mode. If the device has been locked, enter the lock code to unlock it first.

Send data

There can be only one active Bluetooth connection at a time.

- 1 Open an application where the item you wish to send is stored.
- 2 Scroll to the item you want to send, and select **Options > Send > Via Bluetooth**.

The device starts to search for devices within range.

Paired devices are shown with .

When searching for devices, some devices may show only the unique device addresses. To find out the unique address of your device, enter the code ***#2820#** in the standby mode.

If you have searched for devices earlier, a list of the devices that were found previously is shown first. To start a new search, select **More devices**.

- 3 Select the device with which you want to connect.
- 4 If the other device requires pairing, enter a passcode (1-16 digits) and agree with the owner of the other device to use the same code.

When the connection has been successfully established, **Sending data** is displayed.

Data received using Bluetooth connection can be found in **Inbox** in **Messaging**.

Paired devices view

Paired devices are indicated by  in the search result list. In the Bluetooth main view, scroll right to open a list of paired devices.

Do not accept Bluetooth connections from sources you do not trust.

To pair with a device, select **Options > New paired device**. Select the device with which to pair. Exchange passcodes.

To cancel pairing, scroll to the device whose pairing you want to cancel and press the clear key. If you want to cancel all pairings, select **Options > Delete all**.

To set a device to be authorized () and automatically allow connections between your phone and the device without accepting the connection, scroll to the device, and select **Options > Set as authorised**. Use this status only for devices you own or devices that belong to someone you trust. To disallow automatic connections, select **Set as unauthorised**.

Receive data

When you receive data using Bluetooth technology, a tone sounds, and you are asked if you want to accept the message. If you accept, the item is placed in **Inbox** in **Messaging**.

Disconnect Bluetooth connection

A Bluetooth connection is disconnected automatically after sending or receiving data.

USB data cable

Select **Menu > Settings > Connectivity > USB**. To select the default USB connection mode, select **USB mode** and the desired mode. To have the device ask the purpose of the connection each time the cable is connected, select **Ask on connection > Yes**.

To use the device with Nokia PC Suite, select **PC Suite**. To synchronize media files, such as music, with a compatible version of Windows Media Player, select **Media player**. To access files on the inserted memory card as a removable drive, select **Data transfer**.

After transferring data, ensure that it is safe to unplug the USB data cable from the PC.

Remote synchronization

Select **Menu > Settings > Connectivity > Sync**.

Sync enables you to synchronize your calendar, contacts, or notes with various calendar and address book applications on a compatible computer or on the internet. The synchronization application uses SyncML technology for synchronization.

Create a new synchronization profile

- 1 If no profiles have been defined, the device asks you if you want to create a new profile. Select **Yes**.
- 2 To create a new profile in addition to existing ones, select **Options > New sync profile**. Choose whether you want to use the default setting values or copy the values from an existing profile to be used as the basis for the new profile.
- 3 Define the **Applications** to be synchronized. Select an application, and edit the synchronization settings:
 - Include in sync** – to enable or disable the synchronization
 - Remote database** – the name of the used remote database

Synchronisation type – Select **Both ways** for synchronization of the data on your device and the remote database, **To phone only** for the synchronization of the data on your device only, or **To server only** for the synchronization of the data on the remote database only.

- 4 Define the **Connection settings**: **Server version**, **Server ID**, **Data bearer**, **Host address**, **Port**, **User name**, and **Password** – Contact your service provider or system administrator for the correct settings.

Access point – Only visible if **Internet** is selected as **Data bearer**. Select an access point you want to use for the data connection.

Allow sync requests > **Yes** – to allow that the server starts the synchronization

Accept all sync requests > **No** – to require a confirmation before the server starts the synchronization

Network authentication – Only visible if **Internet** is selected as **Data bearer**. To use HTTPS authentication, select **Yes**, and enter user name and password in **Network user name** and **Network password**.

Synchronize data

In the main view, scroll to a profile, and select **Options** > **Synchronise**. The status of the synchronization is shown.

After synchronization is complete, select **Options** > **View log** to open a log file showing the synchronization status (**Complete** or **Incomplete**) and how many calendar or contact entries have been added, updated, deleted, or discarded (not synchronized) in the device or on the server.

Connection manager

Select **Menu** > **Settings** > **Connectivity** > **Conn. mgr.**

In the connection manager, you can identify the status of multiple data connections, view details on the amount of data sent and received, and end unused connections.



Note: The actual invoice for calls and services from your service provider may vary, depending on network features, rounding off for billing, taxes, and so forth.

View connection details

Scroll to a connection, and select **Options** > **Details**.

End connections

To end a connection, scroll to the connection, and select **Options** > **Disconnect**.

To end all connections, select **Options** > **Disconnect all**.

Push to talk

Push to talk (PTT) (network service) is a real-time voice over IP service (network service) available over a GSM/GPRS network. PTT provides direct voice communication connected with a single keypress.

Before you can use the PTT service, you must define the PTT access point and PTT settings.

In PTT communication, one person talks while the others listen. Speakers take turns responding to each other. Only one group member can talk at a time. The length of time of each turn is limited.

Phone calls always take priority over PTT calls.

Besides the packet data counters, the device registers only one-to-one calls in the recent calls lists in **Log**. The participants should confirm the reception of any communications where appropriate as there is no other confirmation of whether the recipients have heard the call.

To check availability and costs, and to subscribe to the service, contact your service provider. Note that roaming services may be more limited than home network services.

Many of the services available for traditional voice calls (for example, call mailbox) are not available for PTT communications.

Define a PTT access point

Many service providers require you to use an internet access point for your default access point. Other service providers allow you to use a WAP access point.

Settings for PTT

For PTT service settings, contact your service provider.

To view and change PTT settings, select **Menu > Settings > Connectivity > PTT > Options > Settings > User settings** or **Connection settings**.

User settings

Accepted list calls — To see a notification of incoming calls, select **Notify**. To answer PTT calls automatically, select **Auto-accept**. If you do not want to receive PTT calls, select **Not allowed**.

PTT call alert tone — Select the tone for incoming PTT calls. If you want the incoming call alert setting for PTT to follow your profile settings, select **Set by profile**. For example, if your profile is silent, PTT is set to do not disturb (DND) and, except for callback requests, you are not available to others using push to talk.

Callback request tone — Select a tone for callback requests.

Application start-up – To start PTT automatically, select **Always automatic**. To start PTT automatically only while in your home network, select **Auto. in home netw.**

Default nickname – Enter your nickname shown to other users. Your service provider may have disabled the editing of this option.

Show my PTT address – Select **Never** if you want to hide your PTT address from others.

Show my login status – Select whether your status is shown to others.

Connection settings

Contact your PTT service provider for the connection settings.

Log in to PTT

Select **Menu > Settings > Connectivity > PTT**, or press the my own key. PTT automatically logs in to the service when started.

When log in is successful, PTT automatically connects to channels that were active when the application was last closed. If the connection is lost, the device automatically tries to log back in until you exit PTT.

 indicates a PTT connection.

 indicates that PTT is set to do not disturb (DND).

Exit PTT

Select **Menu > Settings > Connectivity > PTT > Options > Exit. Log out from PTT after exiting application?** is displayed. Select **Yes** to log out and close the service. If you want to keep the application active in the background, select **No**.

Make a one-to-one call



Warning: Do not hold the device near your ear when the loudspeaker is in use, because the volume may be extremely loud.

1. Select **Menu > Settings > Connectivity > PTT > Options > Contacts**, scroll to the contact you want to talk to, and press and hold my own key.
2. When the connection has been established, to talk to the other participant, press and hold the my own key while you talk.
3. To end the PTT call, select **Disconnect**, or if there are several PTT calls, select **Options > Disconnect**.

Answer a PTT call

If **Accepted list calls** is set to **Notify** in **User settings**, a short tone notifies you of an incoming call. To accept the

call, select **Accept**. To silence the tone, select **Silence**. To reject the call, press the end key.

Make a PTT group call

To call a group, select **Options** > **Contacts**, select **Options** > **Talk to many**, mark the contacts you want to call, and press my own key.

Callback requests

Send a callback request

If you make a one-to-one call and do not get a response, you can send a request for the person to call you back.

To send a callback request from **Contacts**, scroll to a contact, and select **Options** > **Send callback request**.

Respond to a callback request

When someone sends you a callback request, **1 new callback request** is displayed in the standby mode. Select **Show** to open **Callback inbox**. Scroll to a contact, and press the my own key.

Channels

When you are connected to a channel, all members joined to the channel hear you talking. Up to five channels can be active at the same time. When more than one channel is

active, select **Swap** to change the channel you want to talk to.

Channels are registered with a URL address. One user registers the channel URL in the network by joining the channel the first time.

Create your own channel

- 1 Select **Options** > **PTT channels**.
- 2 Select **Options** > **New channel** > **Create new**.
- 3 Enter a **Channel name**.
- 4 Select a **Channel privacy** level.
- 5 Enter your own nickname in **Nickname**.
- 6 If you want to add a thumbnail image to the group, select **Thumbnail** and an image.
- 7 Select **Done**. When you have created a channel, you are asked if you want to send channel invitations. Channel invitations are text messages.

Join a preconfigured channel

A preconfigured channel is a talk group that is set up by your service provider. Only preconfigured users are allowed to join and use the channel.

- 1 Select **Options** > **PTT channels**.
- 2 Select **Options** > **New channel** > **Add existing**.
- 3 Enter the **Channel name**, **Channel address**, and **Nickname**. You can also add a **Thumbnail**.
- 4 Select **Done**.

Respond to a channel invitation

To save a received channel invitation, select **Options > Save channel**. The channel is added to your PTT contacts, channels view.

PTT sessions

PTT sessions are displayed as call bubbles in the PTT display, giving information about the status of the PTT sessions:

Wait – shown when you press and hold the my own key and somebody else is still speaking in the PTT session

Talk – shown when you press and hold the my own key and get the permission to speak

To disconnect the selected PTT session, select **Options > Disconnect**.

Data transfer

With **Data transfer**, you can copy or synchronize contacts, calendar entries, and possibly other data, such as video clips and images, from a compatible device using a Bluetooth connection.

Depending on the other device, synchronization may not be possible and data can be copied only once.

To transfer or synchronize data, do the following:

- 1 Select **Menu > Settings > Connectivity > Transfer**. If you have not used **Transfer** before, information about the application is displayed. Select **Continue** to start transferring data.
If you have used **Data transfer**, select **Transfer data**.
- 2 When using Bluetooth, the devices need to be paired in order to transfer data.
Depending on the type of the other device, an application may be sent and installed on the other device to enable the data transfer.
- 3 Select what content you want to be transferred to your device.
- 4 Content is transferred to your device. The transfer time depends on the amount of data. You can stop the transfer and continue later.

Data manager

Application manager

You can install two types of applications and software to your device:



J2ME™ applications based on Java™ technology with the extension .jad or .jar. PersonalJava™ applications cannot be installed on your device.



Other applications and software suitable for the Symbian operating system. The installation files have the .sis extension. Only install software specifically designed for your device.

Installation files may be transferred to your device from a compatible computer, downloaded during browsing, or sent to you in a multimedia message, as an e-mail attachment, or using Bluetooth. You can use Nokia Application Installer in Nokia PC Suite to install an application to your device or a memory card.

After you install applications to a compatible memory card, installation files (.sis) remain in the device memory. The files may use large amounts of memory and prevent you from storing other files. To maintain sufficient memory, use Nokia PC Suite to back up installation files to a compatible PC, then use the file manager to remove the

installation files from the device memory. See "PC Suite", p. 87 and "File manager", p. 96. If the .sis file is a message attachment, delete the message from the messaging inbox.

To open **App. manager**, select **Menu > Settings > Data mgr. > App. mgr.**

Install an application



Important: Only install and use applications and other software from trusted sources, such as applications that are Symbian Signed or have passed the Java Verified™ testing.

Before installation, in **App. manager**, scroll to the installation file, and select **Options > View details** to view information such as the application type, version number, and the supplier or manufacturer of the application.

The .jar file is required for installing Java applications. If it is missing, the device may ask you to download it.

To install an application or software package:

- 1 Scroll to an installation file. Applications on the memory card are indicated with .
- 2 Select **Options > Install**.

Alternatively, search the device memory or the memory card, select the application, and press the scroll key to start the installation.

During the installation, the device shows information about the progress of the installation. If you are installing an application without a digital signature or certification, the device displays a warning. Continue installation only if you are sure of the origins and contents of the application.

To view extra information about the application, scroll to it, and select **Options > Go to web address**. This option may not be available with all applications.

To see what software packages have been installed or removed and when, select **Options > View log**.

Remove an application

In the **App. manager** main view, scroll to the software package, and select **Options > Remove**.

Application manager settings

In **App. manager**, select **Options > Settings** and from the following settings:

Software installation — to select if you want to allow installation of all Symbian applications (**All**) or only signed applications (**Signed only**)

Online certificate check — to select if you want **App. manager** to check the online certificates for an application before installing it

Default web address — default address used when checking online certificates

Java applications may attempt to, for example, establish a data connection or send a message. To edit the permissions of an installed Java application and define which access point the application will use, in the main view, scroll to the application, and select **Options > Open**.

File manager

Select **Menu > Settings > Data mgr. > File mgr.**

In the file manager, you can browse, open, and manage files and folders in the device memory or on the memory card.

Open the file manager to see a list of the folders in the device memory. Scroll right to see the folders on the memory card.

View memory consumption

Scroll either right or left to view the device memory or the memory card contents. To check memory consumption of the current memory, select **Options > Memory details**. The

device calculates the approximate amount of free memory for storing data and installing new applications.

In the memory views, you can view the memory consumption of the different applications or file types. If the device memory is getting low, remove some files, or move them to the memory card.

Device manager

You may receive server profiles and configuration settings from your service provider or company information management department.

To open **Device mgr.**, select **Menu > Settings > Data mgr. > Device mgr.** If you have no server profiles defined, the device asks whether you want to define one.

To connect to a server and receive configuration settings for your device, scroll to the server profile, and select **Options > Start configuration.**

To edit a server profile, select **Options > Edit profile** and from the following settings:

Allow configuration – To receive configuration settings from the server, select **Yes**.

Auto-accept all requests – If you want the device to ask for confirmation before accepting a configuration from the server, select **No**.

Contact your service provider, or company information management department for the other server profile settings.

Update software



Warning: If you install a software update, you cannot use the device, even to make emergency calls, until the installation is completed and the device is restarted. Be sure to back up data before accepting installation of an update.

Downloading software updates may involve the transmission of large amounts of data through your service provider's network. Contact your service provider for information about data transmission charges.

Make sure that the device battery has enough power, or connect the charger before starting the update.

To check the current version of the software, select **Menu > Settings > Data mgr. > Device mgr. > Updates.**

It is recommended to save backups of important personal information and files (such as contacts, images and messages) either by using Nokia PC Suite or to a memory card in your phone before updating the software.

- 1 Select **Menu > Settings > Data mgr. > Device mgr. > Updates > Options > Check for updates.** If there are updates available, the device starts downloading.

- 2 After a successful download, answer **Yes** to the confirmation query to continue the installation. To start the installation later, select **No**.

To start the installation process later, select **Menu > Settings > Data mgr. > Device mgr. > Install update**.

If there is one server profile defined, it is used as a default. If no server profile has been defined, the device asks you to create one, or if there are several, to select from a list of servers.

Contact your service provider for server profile settings.

Memory card

Keep all memory cards out of the reach of small children.

Select **Menu > Settings > Data mgr. > Memory**.

For details on inserting a memory card into the phone, see [Get started p. 14](#).

Format memory card

When a memory card is formatted, all data on the card is permanently lost.

To format a new memory card, select **Options > Format memory card > Yes**. When the formatting is complete, enter a name for the memory card.

Backup and restore information

To back up information from phone memory to the memory card, select **Options > Back up phone memory**.

To restore information from the memory card to the phone memory, select **Options > Restore from card**.

You can only back up the phone memory and restore it to the same phone.

Lock and unlock the memory card

To set a password to help prevent unauthorized use, select **Options > Set password**. You are asked to enter and confirm your password. The password can be up to eight characters long.

If you insert another password-protected memory card into your phone, you are prompted to enter the password of the card. To unlock the card, select **Options > Unlock memory card**.

Activation keys

Select **Menu > Settings > Data mgr. > Actv. keys** to view the digital rights activation keys stored in your device.

To view valid keys () that are connected to one or more media files, select **Valid keys**. Group keys, which

contain several keys, are indicated with . To view the keys contained in the group key, select the group key.

To view invalid keys () with which the time period for using the file is exceeded, select **Invalid keys**. To buy more usage time or extend the usage period for a media file, scroll to a key, and select **Options > Get activation key**. It may not be possible to update activation keys if web service message reception is disabled. See "[Service message settings](#)", p. 46.

To view activation keys that are not in use, select **Not in use**. Unused activation keys have no media files connected to them.

To view detailed information such as the validity status and the ability to send the file, scroll to an activation key, and press the scroll key.

Digital rights management

Content owners may use different types of digital rights management (DRM) technologies to protect their intellectual property, including copyrights. This device uses various types of DRM software to access DRM-protected content. With this device you can access content protected with OMA DRM 2.0 and OMA DRM 1.0. If certain DRM software fails to protect the content, content owners may ask that such DRM software's ability to access new DRM-protected content be revoked. Revocation may also prevent renewal of such DRM-protected content already in

your device. Revocation of such DRM software does not affect the use of content protected with other types of DRM or the use of non-DRM-protected content.

Digital rights management (DRM) protected content comes with an associated activation key that defines your rights to use the content.

If your device has OMA DRM protected content, to back up both the activation keys and the content, use the backup feature of Nokia PC Suite. Other transfer methods may not transfer the activation keys which need to be restored with the content for you to be able to continue the use of OMA DRM protected content after the device memory is formatted. You may also need to restore the activation keys in case the files on your device get corrupted.

Some activation keys may be connected to a specific SIM card, and the protected content can be accessed only if the SIM card is inserted in the device.

Battery and charger information

Charging and discharging

Your device is powered by a rechargeable battery. The battery intended for use with this device is BP-5M. This device is intended for use when supplied with power from the following chargers: AC-3, AC-4, AC-5 and DC-4 and CA-44 charging adapter. The battery can be charged and discharged hundreds of times, but it will eventually wear out. When the talk and standby times are noticeably shorter than normal, replace the battery. Use only Nokia approved batteries, and recharge your battery only with Nokia approved chargers designated for this device. Use of an unapproved battery or charger may present a risk of fire, explosion, leakage, or other hazard.

If a battery is being used for the first time or if the battery has not been used for a prolonged period, it may be necessary to connect the charger, then disconnect and reconnect it to begin charging the battery. If the battery is completely discharged, it may take several minutes before the charging indicator appears on the display or before any calls can be made.

Always switch the device off and disconnect the charger before removing the battery.

Unplug the charger from the electrical plug and the device when not in use. Do not leave a fully charged battery connected to a charger, since overcharging may shorten its lifetime. If left unused, a fully charged battery will lose its charge over time.

Always try to keep the battery between 15°C and 25°C (59°F and 77°F). Extreme temperatures reduce the capacity and lifetime of the battery. A device with a hot or cold battery may not work temporarily. Battery performance is particularly limited in temperatures well below freezing.

Do not short-circuit the battery. Accidental short-circuiting can occur when a metallic object such as a coin, clip, or pen causes direct connection of the positive (+) and negative (-) terminals of the battery. (These look like metal strips on the battery.) This might happen, for example, when you carry a spare battery in your pocket or purse. Short-circuiting the terminals may damage the battery or the connecting object.

Do not dispose of batteries in a fire as they may explode. Batteries may also explode if damaged. Dispose of batteries according to local regulations. Please recycle when possible. Do not dispose as household waste.

Do not dismantle, cut, open, crush, bend, deform, puncture, or shred cells or batteries. In the event of a battery leak, do not allow the liquid to come in contact with the skin or eyes. In the event of such a leak, flush your skin or eyes immediately with water, or seek medical help.

Do not modify, remanufacture, attempt to insert foreign objects into the battery, or immerse or expose it to water or other liquids.

Improper battery use may result in a fire, explosion, or other hazard. If the device or battery is dropped, especially on a hard surface, and you believe the battery has been damaged, take it to a service centre for inspection before continuing to use it.

Use the battery only for its intended purpose. Never use any charger or battery that is damaged. Keep your battery out of the reach of small children.

Nokia battery authentication guidelines

Always use original Nokia batteries for your safety. To check that you are getting an original Nokia battery,

purchase it from an authorised Nokia dealer, and inspect the hologram label using the following steps:

Successful completion of the steps is not a total assurance of the authenticity of the battery. If you have any reason to believe that your battery is not an authentic, original Nokia battery, you should refrain from using it. If authenticity cannot be verified, return the battery to the place of purchase.

Authenticate hologram

- 1 When you look at the hologram on the label, you should see the Nokia connecting hands symbol from one angle and the Nokia Original Enhancements logo when looking from another angle.
- 2 When you angle the hologram left, right, down and up, you should see 1, 2, 3 and 4 dots on each side respectively.

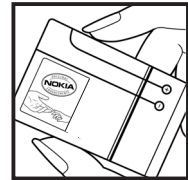

What if your battery is not authentic?

If you cannot confirm that your Nokia battery with the hologram on the label is an authentic Nokia battery, please

Battery and charger information

do not use the battery. The use of a battery that is not approved by the manufacturer may be dangerous and may result in poor performance and damage to your device and its enhancements. It may also invalidate any approval or warranty applying to the device.

To find out more about original Nokia batteries, visit www.nokia-asia.com/batterycheck.



Nokia original enhancements

An extensive range of enhancements is available for your phone. Please visit www.nokia-asia.com/enhancements for more details.

For availability of the enhancements, please check with your local dealer. A few practical rules for enhancements operation:

- Keep the enhancements out of small children's reach.
- When you disconnect the power cord of any accessory, grasp and pull the plug, not the cord.
- Check regularly that all mobile phone equipment in a vehicle is mounted and operating properly.

Use only batteries, chargers and enhancements approved by the phone manufacturer. The use of any other types may invalidate any approval or warranty applying to the phone, and may be dangerous.

BATTERY

Type	Talktime#	Standby#
BP-5M	up to 2.5 hours	up to 11 days



Important: These battery talk and standby times can only be reached in certain optimized network conditions or surroundings. The actual battery talk and standby times may differ depending on SIM card, features used, battery age and condition, temperatures to which battery is exposed, different network conditions, and many other factors, so that the talk and standby times may be significantly shorter than given here. In addition, ringing tones, handsfree, use in digital mode, and other functions consume the power, and the amount of time a device is used for calls will affect its standby time. Likewise, the amount of time that the device is turned on and in the standby mode will affect its talk time.

Nokia Multimedia Car Kit (CK-20W)

Driving has never been this easy. The Nokia Multimedia Car Kit CK-20W integrates the comfort of handsfree usage with superior audio and multimedia options. Nokia GPS Module LD-2 is available as an optional add-on to enable navigation capability on the car kit.

Nokia Holder Easy Mount (HH-12)

The Nokia Holder Easy Mount enables the screwless attachment of a Nokia Mobile Holder to the car windscreen. The compatible mobile holder is traditionally mounted to the mounting plate of the Nokia Holder Easy Mount.

Mobile Holder (CR-48)

The Nokia Mobile Holder is suitable for very wide mobile phone. It fulfils car safety requirements in usage position.

Care and maintenance

Your device is a product of superior design and craftsmanship and should be treated with care. The following suggestions will help you protect your warranty coverage.

- Keep the device dry. Precipitation, humidity, and all types of liquids or moisture can contain minerals that will corrode electronic circuits. If your device does get wet, remove the battery, and allow the device to dry completely before replacing it.
 - Do not use or store the device in dusty, dirty areas. Its moving parts and electronic components can be damaged.
 - Do not store the device in hot areas. High temperatures can shorten the life of electronic devices, damage batteries, and warp or melt certain plastics.
 - Do not store the device in cold areas. When the device returns to its normal temperature, moisture can form inside the device and damage electronic circuit boards.
 - Do not attempt to open the device other than as instructed in this guide.
 - Do not drop, knock, or shake the device. Rough handling can break internal circuit boards and fine mechanics.
 - Do not use harsh chemicals, cleaning solvents, or strong detergents to clean the device.
 - Do not paint the device. Paint can clog the moving parts and prevent proper operation.
 - Use a soft, clean, dry cloth to clean any lenses, such as camera, proximity sensor, and light sensor lenses.
- Use only the supplied or an approved replacement antenna. Unauthorized antennas, modifications, or attachments could damage the device and may violate regulations governing radio devices.
 - Use chargers indoors.
 - Always create a backup of data you want to keep, such as contacts and calendar notes.
 - To reset the device from time to time for optimum performance, power off the device and remove the battery.

These suggestions apply equally to your device, battery, charger, or any enhancement. If any device is not working properly, take it to the nearest authorized service facility for service.

Additional safety information

Small children

Your device and its enhancements may contain small parts. Keep them out of the reach of small children.

Operating environment

This device meets RF exposure guidelines when used either in the normal use position against the ear or when positioned at least 2.2 centimeters away from the body. When a carry case, belt clip, or holder is used for body-worn operation, it should not contain metal and should position the device the above-stated distance from your body. To transmit data files or messages, this device requires a quality connection to the network. In some cases, transmission of data files or messages may be delayed until such a connection is available. Ensure the above separation distance instructions are followed until the transmission is completed.

Parts of the device are magnetic. Metallic materials may be attracted to the device. Do not place credit cards or other magnetic storage media near the device, because information stored on them may be erased.

Medical devices

Operation of any radio transmitting equipment, including wireless phones, may interfere with the functionality of inadequately protected medical devices. Consult a physician or the manufacturer of the medical device to determine if they are adequately shielded from external RF energy or if you have any questions. Switch off your device in health care facilities when any regulations posted in these areas instruct you to do so. Hospitals or health care facilities may be using equipment that could be sensitive to external RF energy.

Implanted medical devices Manufacturers of medical devices recommend that a minimum separation of 15.3 centimeters (6 inches) should be maintained between a wireless device and an implanted medical device, such as a pacemaker or implanted cardioverter defibrillator, to avoid potential interference with the medical device. Persons who have such devices should:

- Always keep the wireless device more than 15.3 centimeters (6 inches) from the medical device when the wireless device is turned on.
- Not carry the wireless device in a breast pocket.

- Hold the wireless device to the ear opposite the medical device to minimize the potential for interference.
- Turn the wireless device off immediately if there is any reason to suspect that interference is taking place.
- Read and follow the directions from the manufacturer of their implanted medical device.

If you have any questions about using your wireless device with an implanted medical device, consult your health care provider.

Hearing aids Some digital wireless devices may interfere with some hearing aids. If interference occurs, consult your service provider.

Vehicles

RF signals may affect improperly installed or inadequately shielded electronic systems in motor vehicles such as electronic fuel injection systems, electronic antiskid (antilock) braking systems, electronic speed control systems, and air bag systems. For more information, check with the manufacturer, or its representative, of your vehicle or any equipment that has been added.

Only qualified personnel should service the device or install the device in a vehicle. Faulty installation or service may be dangerous and may invalidate any warranty that may apply to the device. Check regularly that all wireless device equipment in your vehicle is mounted and operating properly. Do not store or carry flammable liquids, gases, or explosive materials in the same compartment as the device, its parts, or enhancements.

For vehicles equipped with an air bag, remember that air bags inflate with great force. Do not place objects, including installed or portable wireless equipment in the area over the air bag or in the air bag deployment area. If in-vehicle wireless equipment is improperly installed and the air bag inflates, serious injury could result.

Using your device while flying in aircraft is prohibited. Switch off your device before boarding an aircraft. The use of wireless teledevices in an aircraft may be dangerous to the operation of the aircraft, disrupt the wireless telephone network, and may be illegal.

Potentially explosive environments

Switch off your device when in any area with a potentially explosive atmosphere, and obey all signs and instructions. Potentially explosive atmospheres include areas where you would normally be advised to turn off your vehicle engine. Sparks in such areas could cause an explosion or fire resulting in bodily injury or even death. Switch off the device at refuelling points such as near gas pumps at service stations. Observe restrictions on the use of radio equipment in fuel depots, storage, and distribution areas; chemical plants; or where blasting operations are in progress. Areas with a potentially explosive atmosphere are often, but not always, clearly marked. They include below deck on boats, chemical transfer or storage facilities and areas where the air contains chemicals or particles such as grain, dust, or metal powders. You should check with the manufacturers of vehicles using liquefied petroleum (such as propane or butane) to determine if this device can be safely used in their vicinity.

Emergency calls



Important: This device operates using radio signals, wireless networks, landline networks, and user-programmed functions. If your device supports voice calls over the internet (internet calls), activate both the internet calls and the cellular phone. The device will attempt to make emergency calls over both the cellular networks and through your internet call provider if both are activated. Connections in all conditions cannot be guaranteed. You should never rely solely on any wireless device for essential communications like medical emergencies.

When making an emergency call, give all the necessary information as accurately as possible. Your wireless device may be the only means of communication at the scene of an accident. Do not end the call until given permission to do so.

To make an emergency call:

- 1 If the device is not on, switch it on. Check for adequate signal strength. Depending on your device, you may also need to complete the following:
 - Insert a SIM card if your device uses one.
 - Remove certain call restrictions you have activated in your device.
 - Change your profile from offline or flight profile mode to an active profile.
- 2 Press the end key as many times as needed to clear the display and ready the device for calls.
- 3 Enter the official emergency number for your present location. Emergency numbers vary by location.
- 4 Press the call key.

Certification information (SAR)

This mobile device meets guidelines for exposure to radio waves.

Your mobile device is a radio transmitter and receiver. It is designed not to exceed the limits for exposure to radio waves recommended by international guidelines. These guidelines were developed by the independent scientific organization ICNIRP and include safety margins designed to assure the protection of all persons, regardless of age and health.

The exposure guidelines for mobile devices employ a unit of measurement known as the Specific Absorption Rate or SAR. The SAR limit stated in the ICNIRP guidelines is 2.0 watts/kilogram (W/kg) averaged over 10 grams of tissue. Tests for SAR are conducted using standard operating positions with the device transmitting at its highest certified power level in all tested frequency bands. The actual SAR level of an operating device can be below the maximum value because the device is designed to use only the power required to reach the network. That amount changes depending on a number of factors such as how close you are to a network base station. The highest SAR value under the ICNIRP guidelines for use of the device at the ear is 1.16 W/kg.

Use of device accessories and enhancements may result in different SAR values. SAR values may vary depending on national reporting and testing requirements and the network band. Additional SAR information may be provided under product information at www.nokia.com.

Index

- A**
access codes
 barring password 22
 change 77
 lock code 16, 21
 PIN 16, 22
 PUK 22
access points 82
activation keys 98
active standby 19
Adobe Reader 70
alarm clock. See clock.
application manager 95
applications 95
- B**
BATTERY 103
battery charging 16
Bluetooth
 connection settings 87
 disconnecting 89
 paired devices 88
 receiving data 89
 sending data 88
bookmarks 60–61
- browser. See web.
- C**
cache 63
calendar 66
call register. See log.
callback requests 91, 93
calls
 answering 25
 barring 81
 conference call 25
 diverting 80
 ending 24
 international 24
 making 24
 rejecting 25, 26
 rejecting with SMS 26
 speed dialing 24, 49
 swapping 26
 voice mailbox 24
 waiting 26
camera 53
certificates 78
clock 66
connection manager 90
- connectivity 87
contacts 48
converter 67
copyright protection. See activation keys.
- D**
data cable 89
data connection indicators 19
data transfer 94
device manager 97
- E**
e-mail
 mailbox 42
 settings 41
e-mail messages 42
enhancements 77
- F**
file manager 96
- G**
gallery 50
GPS data 69
- H**
help 12

- I**
- IM. See instant messaging.
 - indicators 19
 - instant messaging
 - connecting 84
 - contacts 86
 - conversation 86
 - groups 85, 86
 - settings 84
- K**
- keyguard. See keypad lock.
 - keypad lock 21
- L**
- landmarks 70
 - log 29
- M**
- media player. See RealPlayer.
 - memory card 98
 - menu 20
 - message settings
 - cell broadcast 46
 - e-mail 45
 - multimedia settings 44
 - other settings 46
 - service messages 46
 - text messages 43
 - messages
 - audio 40
 - cell broadcast 43
 - listening to 47
 - multimedia objects 41
 - organizing 41
 - outbox 43
 - receiving 41
 - sending 39
 - service commands 43
 - service messages 41
 - special message types 41
 - writing 39
 - mobile browser. See web.
 - Mobile Holder (CR-48) 104
 - music player
 - library 54
 - listening to music 55
 - my own key 22
- N**
- Navigator 31
 - browse the map 34
 - navigate to locations 33
 - navigator application 32
 - plan trips 35
 - network 81
 - Nokia Holder Easy Mount (HH-12) 104
 - Nokia Multimedia Car Kit (CK-20W) 104
 - Nokia original enhancements 103
 - notes 67
- O**
- office applications 71
 - one-touch dial. See speed dialing.
- P**
- phone memory 96
 - phonebook. See contacts.
 - profiles 73
 - PTT. See push to talk.
 - push to talk 91–94
- Q**
- Quickoffice 71
- R**
- Radio 56
 - RealPlayer 56
- S**
- services. See web.
 - settings
 - connection 81
 - data call 83
 - date 76
 - enhancements 77
 - packet data 82
 - phone 75
 - phone language 75
 - predictive text input 76
 - security 77

Index

- Setting wizard 84
- speech 84
- time 76
- writing language 76

speed dialing

- assigning a phone number 49, 83
- calling 24

standby mode 19

synchronization 89

T

text input 37–38, 76

themes 74

to-do 67

U

USB. See data cable.

V

video call 26, 27

voice commands 74

voice dialing 24

voice mailbox 84

volume 21

W

web

- blogs 62
- browser settings 63
- browsing 61
- connecting 60

- connection security 61
- disconnecting 63
- feeds 62
- saving a page 62
- settings 60
- viewing a saved page 62
- viewing bookmarks 60

writing text. See text input

Nokia Care Online

The Nokia Care web support provides you with more information on our online services.

INTERACTIVE DEMONSTRATIONS



INTERACTIVE DEMONSTRATIONS

Learn how to set up your phone for the first time, and find out more about its features. Interactive Demonstrations give step-by-step instructions on using your phone.

SOFTWARE



USER'S GUIDE

The online User's Guide contains detailed information on your phone. Remember to check regularly for updates.



SOFTWARE

Make the most of your phone with software for your phone and PC. Nokia PC Suite connects your phone and PC so you can manage your calendar, contacts, music and images, while other applications complement its use.



USER'S GUIDE

SETTINGS

Certain phone functions, such as multimedia messaging, mobile browsing and email*, may require settings before you can use them. Have them sent to your phone free of charge.



SETTINGS

*Not available on all phones.

HOW DO I USE MY PHONE?

The Set Up section, at www.nokia-asia.com/setup, helps you prepare your phone for use. Familiarise yourself with phone functions and features by referring to the Guides and Demos section at www.nokia-asia.com/guides.

HOW DO I SYNCHRONISE MY PHONE AND PC?

Connecting your phone to a compatible PC with the requisite Nokia PC Suite version from www.nokia-asia.com/pcsuite lets you synchronise your calendar and contacts.

WHERE CAN I GET SOFTWARE FOR MY PHONE?

Get more out of your phone with downloads from the Software section at www.nokia-asia.com/software.

WHERE CAN I FIND ANSWERS TO COMMON QUESTIONS?

Look up the FAQ section at www.nokia-asia.com/faq for answers to your questions on your phone and other Nokia products and services.

HOW DO I KEEP UP WITH NOKIA NEWS?

Subscribe online at www.nokia-asia.com/signup and be the first to know about the latest products and promotions. Sign up for "Nokia Connections" to receive monthly updates on latest phones and technology. Sign up for "Be The First To Know" to get exclusive previews of new phone announcements or subscribe to "Promotional Communications" for upcoming events.

Should you still require further assistance, please refer to www.nokia-asia.com/contactus.

For additional information on repair services, please visit www.nokia-asia.com/repair.

Please visit your own country site for more details:

Australia and New Zealand

www.nokia.com.au/support

India

www.nokia.co.in/support

Indonesia

www.nokia.co.id/support

Japan

www.nokia.co.jp/support

Vietnam

www.nokia.com.vn/support

Malaysia

www.nokia.com.my/support

Philippines

www.nokia.com.ph/support

Singapore

www.nokia.com.sg/support

Thailand

www.nokia.co.th/support

If your country is not listed above, please visit www.nokia-asia.com/support.

NOKIA

Care