

TECHNICAL MANUAL
Of
Intel Pine Trail-D & NM10 Chipset
Based
Mini-ITX M/B for ATOM Processor

NO.G03-NC94-F

Rev 3.0

Release date: August, 2010

Trademark:

* Specifications and Information contained in this documentation are furnished for information use only, and are subject to change at any time without notice, and should not be construed as a commitment by manufacturer.

Environmental Protection Announcement

Do not dispose this electronic device into the trash while discarding. To minimize pollution and ensure environment protection of mother earth, please recycle.



TABLE OF CONTENT

ENVIRONMENTAL SAFETY INSTRUCTION.....	iii
USER'S NOTICE	iv
MANUAL REVISION INFORMATION.....	iv
ITEM CHECKLIST	iv
CHAPTER 1 INTRODUCTION OF THE MOTHERBOARD	
1-1 FEATURE OF MOTHERBOARD.....	1
1-2 SPECIFICATION	2
1-3 LAYOUT DIAGRAM.....	3
CHAPTER 2 HARDWARE INSTALLATION	
2-1 JUMPER SETTING	6
2-2 CONNECTORS AND HEADERS.....	9
2-2-1 CONNECTORS	9
2-2-2 HEADERS	10
CHAPTER 3 INTRODUCING BIOS	
3-1 ENTERNING SETUP.....	17
3-2 GETTING HELP	17
3-3 THE MAIN MENU.....	17
3-4 STANDARD BIOS FEATURES	19
3-5 ADVANCED BIOS FEATURES	21
3-5-1 CPU FEATURE	23
3-6 ADVANCED CHIPSET FEATURES	24
3-7 INTEGRATED PHERIPHRALS	25
3-7-1 ONBOARD SATA FUNCTION	25
3-7-2 ONBOARD DEVICE FUNCTION.....	26
3-7-3 ONBOARD SUPER IO FUNCTION.....	27
3-8 POWER MANAGEMENT SETUP.....	28
3-9 PNP/PCI CONFIGURATIONS.....	29
3-10 PC HEALTH STATUS.....	29
3-11 MISCELLANEOUS CONTROL.....	31
3-12 PASSWORD SETTING	32
3-13 LOAD OPTIMIZED /STANDARDDEFAULTS	33
3-14 SAVE AND EXIT SETUP/EXIT WITHOUT SAVING	33



Environmental Safety Instruction

- Avoid the dusty, humidity and temperature extremes. Do not place the product in any area where it may become wet.
- 0 to 60 centigrade is the suitable temperature. (The figure comes from the request of the main chipset)
- Generally speaking, dramatic changes in temperature may lead to contact malfunction and crackles due to constant thermal expansion and contraction from the welding spots' that connect components and PCB. Computer should go through an adaptive phase before it boots when it is moved from a cold environment to a warmer one to avoid condensation phenomenon. These water drops attached on PCB or the surface of the components can bring about phenomena as minor as computer instability resulted from corrosion and oxidation from components and PCB or as major as short circuit that can burn the components. Suggest starting the computer until the temperature goes up.
- The increasing temperature of the capacitor may decrease the life of computer. Using the close case may decrease the life of other device because the higher temperature in the inner of the case.
- Attention to the heat sink when you over-clocking. The higher temperature may decrease the life of the device and burned the capacitor.

USER'S NOTICE

COPYRIGHT OF THIS MANUAL BELONGS TO THE MANUFACTURER. NO PART OF THIS MANUAL, INCLUDING THE PRODUCTS AND SOFTWARE DESCRIBED IN IT MAY BE REPRODUCED, TRANSMITTED OR TRANSLATED INTO ANY LANGUAGE IN ANY FORM OR BY ANY MEANS WITHOUT WRITTEN PERMISSION OF THE MANUFACTURER.

THIS MANUAL CONTAINS ALL INFORMATION REQUIRED TO USE THIS MOTHER-BOARD SERIES AND WE DO ASSURE THIS MANUAL MEETS USER'S REQUIREMENT BUT WILL CHANGE, CORRECT ANY TIME WITHOUT NOTICE. MANUFACTURER PROVIDES THIS MANUAL "AS IS" WITHOUT WARRANTY OF ANY KIND, AND WILL NOT BE LIABLE FOR ANY INDIRECT, SPECIAL, INCIDENTAL OR CONSEQUENTIAL DAMAGES (INCLUDING DAMAGES FOR LOSS OF PROFIT, LOSS OF BUSINESS, LOSS OF USE OF DATA, INTERRUPTION OF BUSINESS AND THE LIKE).

PRODUCTS AND CORPORATE NAMES APPEARING IN THIS MANUAL MAY OR MAY NOT BE REGISTERED TRADEMARKS OR COPYRIGHTS OF THEIR RESPECTIVE COMPANIES, AND THEY ARE USED ONLY FOR IDENTIFICATION OR EXPLANATION AND TO THE OWNER'S BENEFIT, WITHOUT INTENT TO INFRINGE.

Manual Revision Information

Reversion	Revision History	Date
2.0	Second Edition	June, 2010

Item Checklist

- Motherboard
- Cable(s)
- DVD for motherboard utilities
- Motherboard User's Manual
- I/O Back panel shield

Chapter 1

Introduction of the Motherboard

1-1 Feature of motherboard

- Intel Pine Trail-D & NM10 Chipset.
- Onboard Intel Atom CPU, with low power consumption never denies high performance.
- Support CPU CLK 166 MHz
- Support DDRII DIMM 667/800 up to 4GB.
- Support PCI-Ex16 (by 4 lane) card.
- Onboard INTEL 82552V Megabit Ethernet LAN PHY Chip.
- Integrated ALC662 6-channel HD audio CODEC.
- Support USB2.0 data transport demands.
- Support RS232/422/485 and watchdog.

1-2 Specification

Spec	Description
Design	<ul style="list-style-type: none"> ● Mini-ITX form factor ; PCB size: 17.0x17.0cm
Chipset	<ul style="list-style-type: none"> ● Intel Pine Trail-D + NM10 Chipset
Embedded CPU	<ul style="list-style-type: none"> ● ATOM CPU
Memory Socket	<ul style="list-style-type: none"> ● 240-pin DDRII DIMM slot x2 ● Support DDRII 667/800 MHz DDRII memory modules ● Expandable to 4 GB
Expansion Slots	<ul style="list-style-type: none"> ● PCI Expressx16(by 4) slot x 1
LAN	<ul style="list-style-type: none"> ● Integrated INTEL 82552V Megabit Ethernet LAN that supports Fast Ethernet LAN function of providing 10Mb/100Mb Ethernet data transfer rate
Audio	<ul style="list-style-type: none"> ● ALC662 6-channel Audio Codec integrated ● Audio driver and utility included
BIOS	<ul style="list-style-type: none"> ● AMI 8MB DIP Flash ROM
Multi I/O	<ul style="list-style-type: none"> ● PS/2 keyboard connector x1 ● PS/2 mouse connector x1 ● Serial port connector x1 ● VGA port connector x1 ● Parallel port Connector x1 ● Floppy Disk Drive Connector x1 ● USB port connector x4 and USB header x2 ● RJ-45 LAN connector x1 ● Audio connector x1 (Line-in, Line-out, MIC) ● SATAII Connector x2 ● Front panel audio header x1 ● Serial port header x1 ● RS232/422/RS485 header x1 ● LVDS header x1 ● LPC header x1 ● GPIO header x1

1-3 Layout Diagram

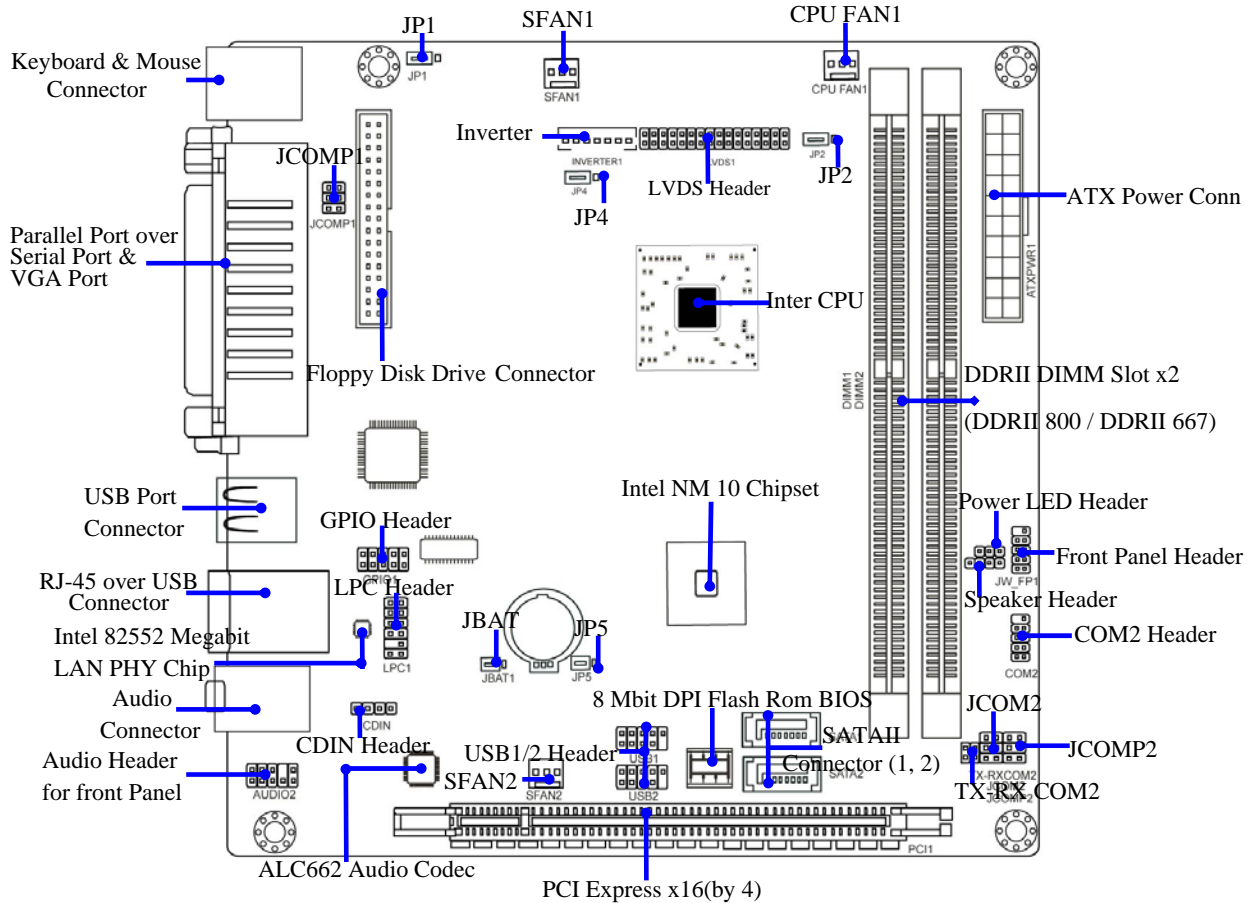
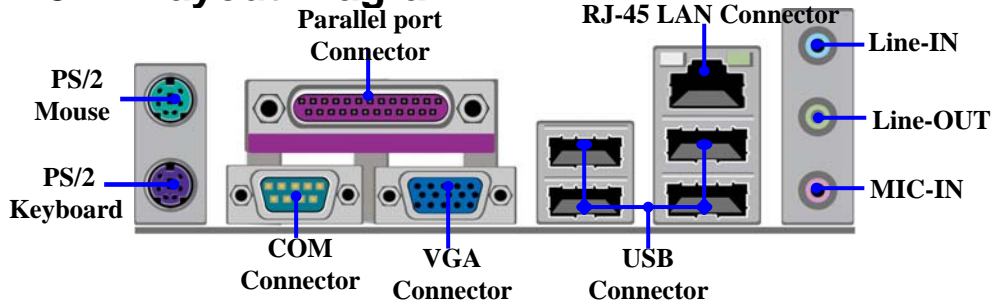

Jumper

Jumper	Name	Description
JBAT1	CMOS RAM Clear Function Setting	3-pin Block
JP2	LVDS PVCC 5V/3.3V Select	3-pin Block
JP4	Inverter12V/5V Select	3-pin Block
JP5	USB 1/2 Power On Function Setting	3-pin Block
JCOM2	COM2 RS232/422/485 Function Select	6 pin Block
JCOMP1	Power RS232 Function Select	6 pin Block
JCOMP2	Power RS232 Function Select	6 pin Block

Connectors

Connector	Name	Description
ATXPWR1	ATX Power Connector	20-pin Connector
KB1	PS2 Keyboard & Mouse Connector	6-pin Female
COM1	Serial Port COM Connector	9-pin Connector
PARALLEL	Parallel Port Connector	25-pin Connector
VG1	Video Graphic Attach Connector	15-pin Female
USB 3	USB Port Connectors	4-pin Connectors
USB from UL1	USB Port Connectors	4-pin Connectors
LAN from UL1	RJ-45 LAN Connectors	8-pin Connectors
AUDIO1	Line Out /Line In /MIC Audio Connector	3 Phone JACK
SATA1/SATA2	Serial ATAll Connectors	7-pin Connector
FLOPPY1	Floppy Disk Drive Connector	33-pin Block

Headers

Header	Name	Description
AUDIO2	Front panel audio Headers	9-pin block
CDIN1	CD Audio-In Header	4-pin Block
LVDS1	LVDS Header	32-pin Block
INVERTER1	LVDS Inverter Connector	7-pin Block
COM2	Serial Port Header	9-pin Block
TX-RX COM2	RS 232/422/485 port headers	4-pin block
USB1; USB2	USB Headers	9-pin Block
JW_FP1 (PWR LED/ HD LED/ /Power Button /Reset)	Front Panel Header (PWR LED/ HD LED/ Button /Reset)	9-pin Block
PWR LED1	Power LED	3-pin Block
SPEAK	Speaker Header	4-pin Block
CPUFAN1,SFAN1/2	FAN Speed Headers	3-pin Block
GPIO1	GPIO Header	10-pin Block
LPC1	LPC1 Header	11-pin Block

Chapter 2 Hardware Installation

2-1 Jumper Setting

(1) Clear CMOS (3-pin): JBAT1

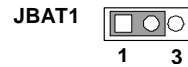
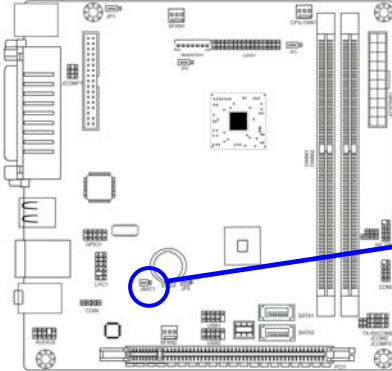

1-2 closed Normal

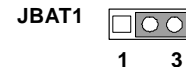

2-3 closed Clear CMOS

CMOS RAM Clear Setting

(2) KB/USB Power On Function Setting: JP1

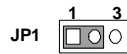
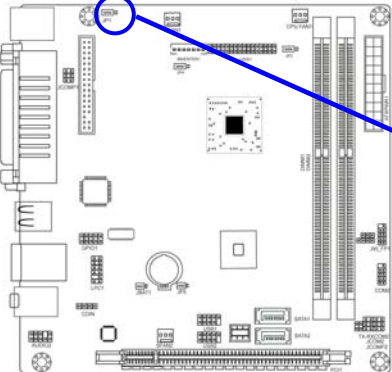

1-2 Closed: K.B&USB POWER-ON Disacled(default)

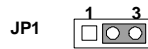

2-3 closed: K.B & USB POWER-ON Enabled

(3) JP2: LVDS PVCC 5V / 3.3V Function setting (3-pin)

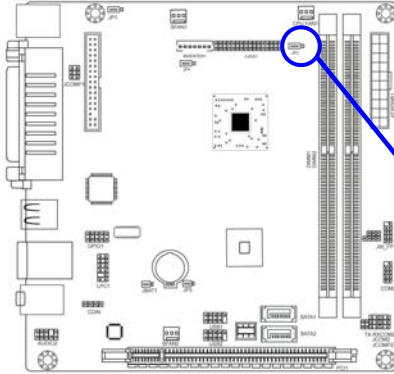

JP2



1 3

1-2 closed: LVDS PVCC 5V

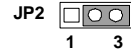

1 3

2-3 closed : LVDS PVCC 3.3V

(4) JP4: Inverter 5V/12V Select (3-pin)

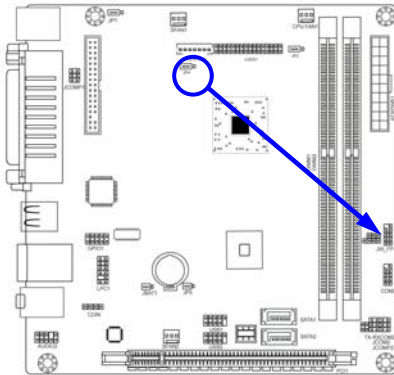

JP4



1 3

1-2 closed
Inverter 12V selected

JP4



1 3

2-3 closed
Inverter 5V select

(5) JP5: USB1/2 Power On Function Setting: JP5

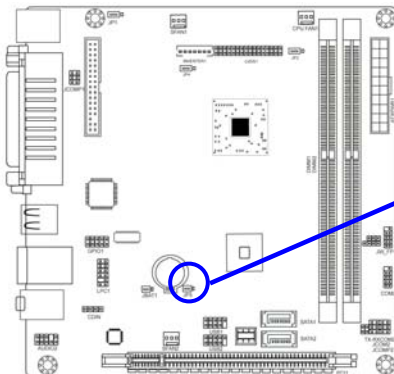

JP5



1 3

1-2 closed : USB 1/2 Header POWER-ON Disacted(default)

JP5

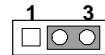

1 3

2-3 closed: USB 1/2 Header POWER-ON Enabled

(6) JCOM2: COM2 Port RS232/485/422 Function Select

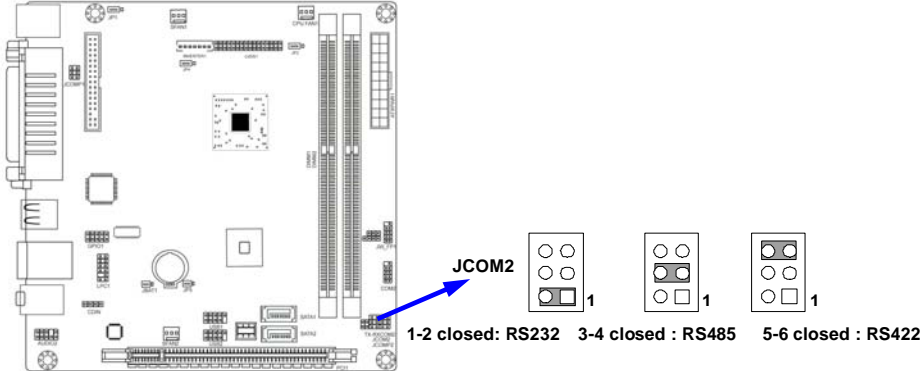

(7) JCOMP1: COM1 Pin9 function select

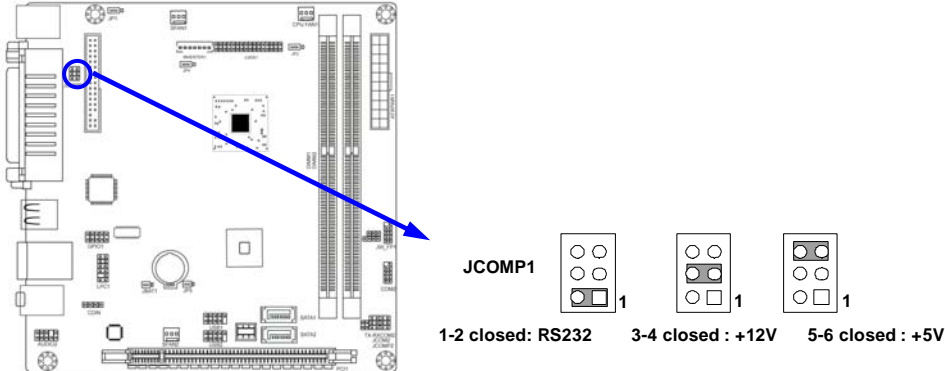

(8) JCOMP2: COM2 Pin9 function select

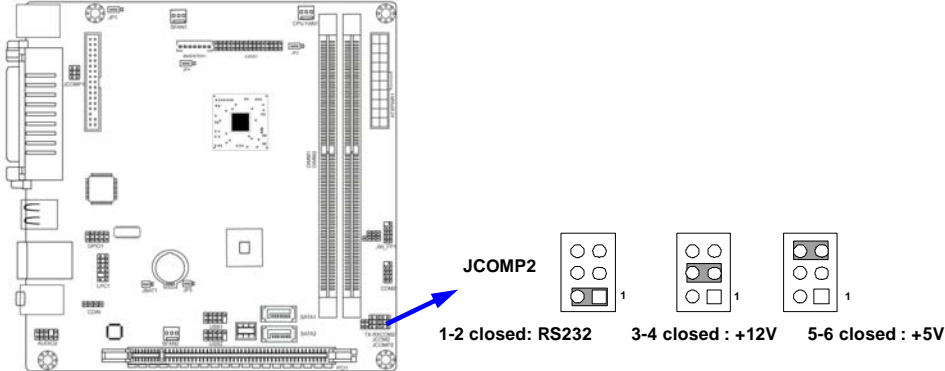

2-2 Connectors and Headers

2-2-1 Connectors

(1) Audio Connector: (Line-IN/ Line-Out/ MIC-In)

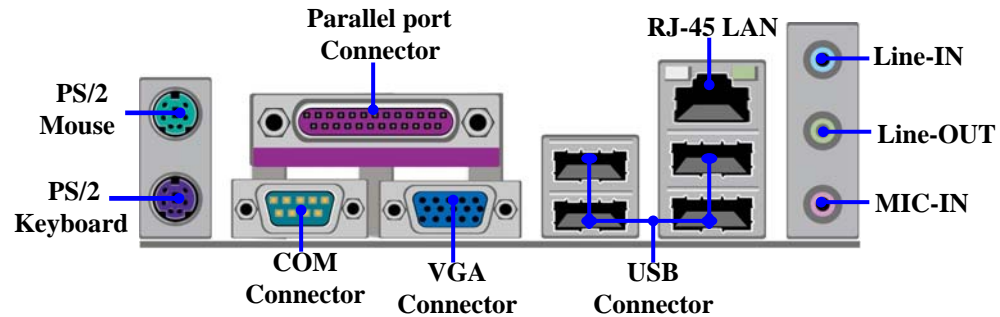

(2) Serial-ATA Port connector: SATA1/SATA2

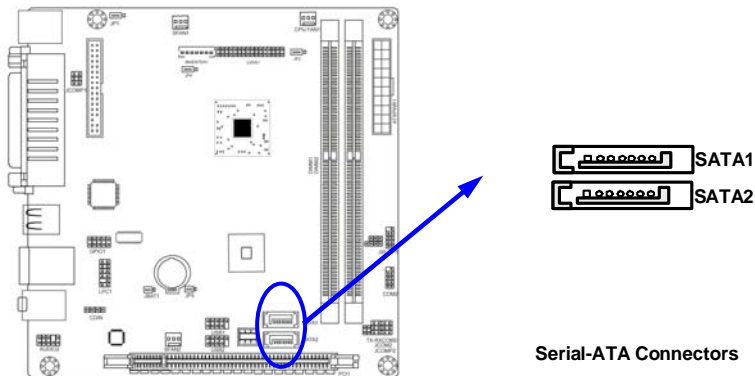

(4) Floppy drive Connector (33-pin block): FLOPPY1

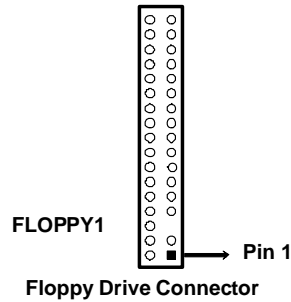
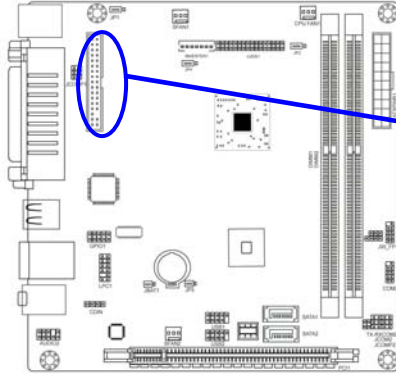

2-2-2 Headers

(1) Line-Out, MIC-In Header (9-pin): Front Panel Audio Header: AUDIO2

This header connects to Front Panel Line-out, MIC-In connector with cable.

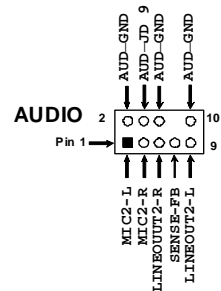
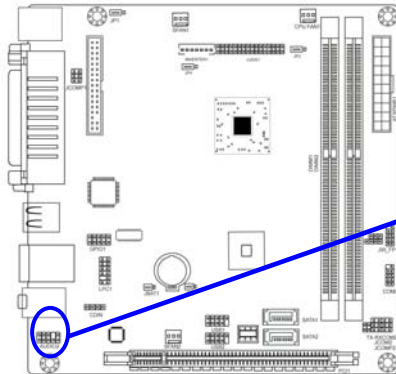

Line-Out, MIC Headers

(2) CD AUDIO-In Headers (4-pin): CDIN1

CDIN are the connectors for CD-Audio Input signal. Please connect it to CD-ROM CD-Audio output connector.

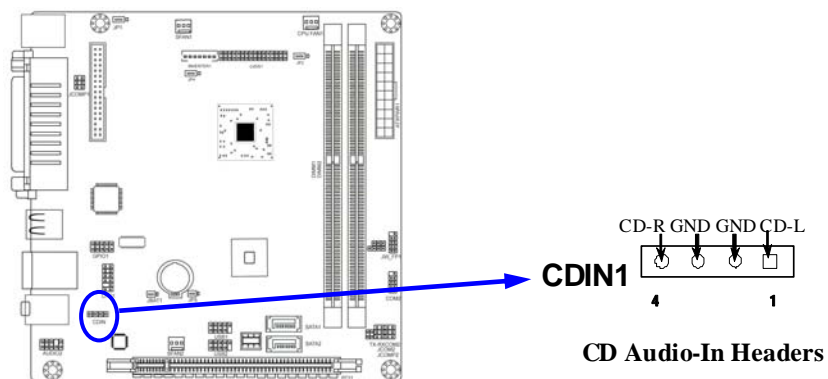

(3) LVDS Headers (32 Pin) : LVDS1

Pin NO.	Pin Define	Pin NO.	Pin Define
Pin 1	NC	Pin 2	NC
Pin 3	NC	Pin 4	NC
Pin 5	NC	Pin 6	NC
Pin 7	NC	Pin 8	NC
Pin 9	NC	Pin 10	NC
Pin 11	LVDS_DDC_DATA	Pin 12	LVDS_DDC_CLK
Pin 13	GND	Pin 14	GND
Pin 15	GND	Pin 16	GND
Pin 17	NC	Pin 18	NC
Pin 19	LVDS_CLKAP	Pin 20	LVDS_CLKAN
Pin 21	LVDSA_DATAP2	Pin 22	LVDSA_DATAN2
Pin 23	LVDSA_DATAP1	Pin 24	LVDSA_DATAN1
Pin 25	LVDSA_DATAP0	Pin 26	LVDSA_DATAN0
Pin 27	PVDD	Pin 28	PVDD
Pin 29	PVDD	Pin 30	PVDD
Pin 31	GND	Pin 32	GND

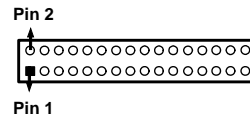
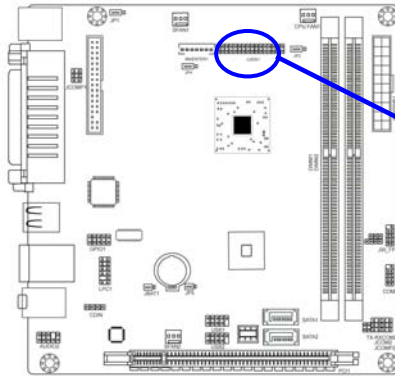

LVDS1

(4) LVDS Inverter headers: Inverter1

Pin 1 and pin2: VCC of inverter

Pin3, pin4 and pin6: GND

Pin5: Backlight

Pin7: Brightness

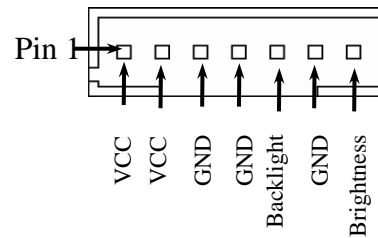
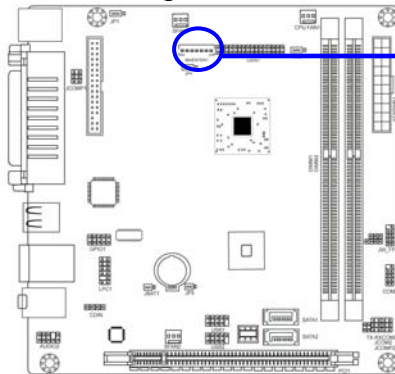

(5) Serial Port Connectors (9-Pin female): COM2

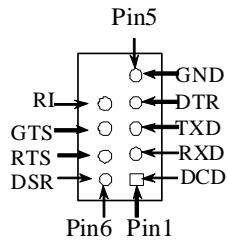
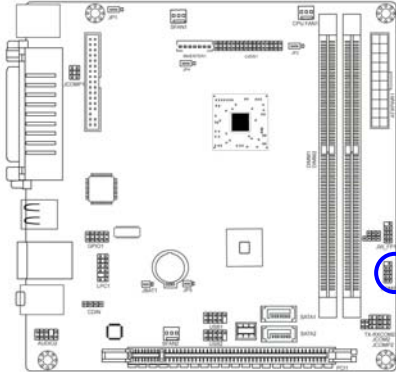

Serial COM Port 9-pin Block

(6) RS232/422/485 Header: TX-RXCOM2

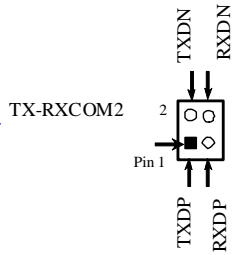
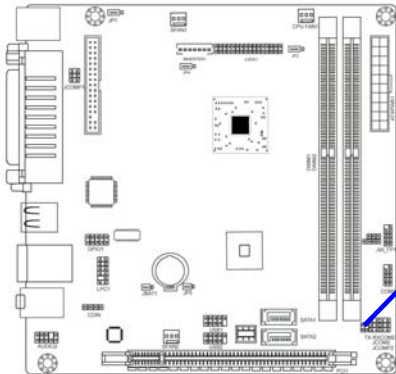

TX-RXCOM2 Header

(7) USB Port Headers (9-pin): USB1/USB2

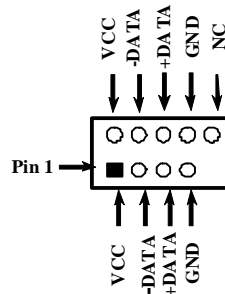
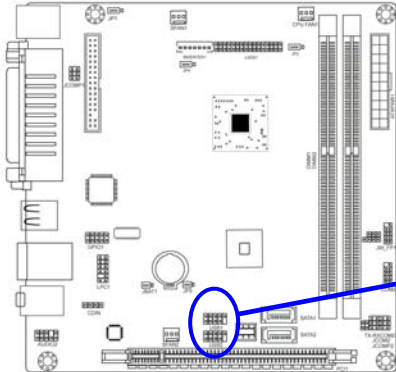

USB Port Header

(8) Speaker connector: SPEAK1

This 4-pin connector connects to the case-mounted speaker. See the figure below.

(9) Power LED: PWR LED

The Power LED is light on while the system power is on. Connect the Power LED from the system case to this pin.

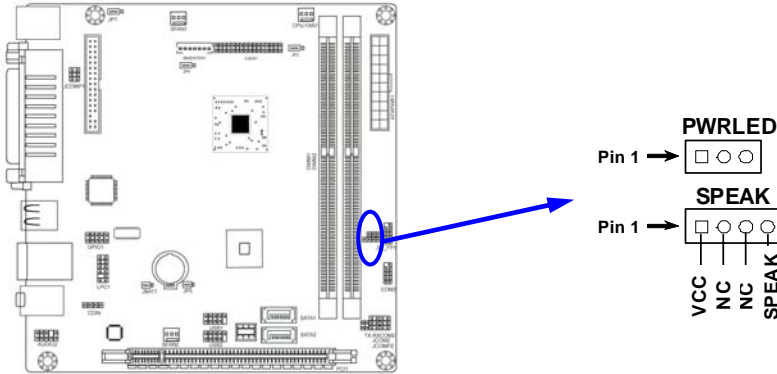

(9) Front Panel Header: JW-FP1

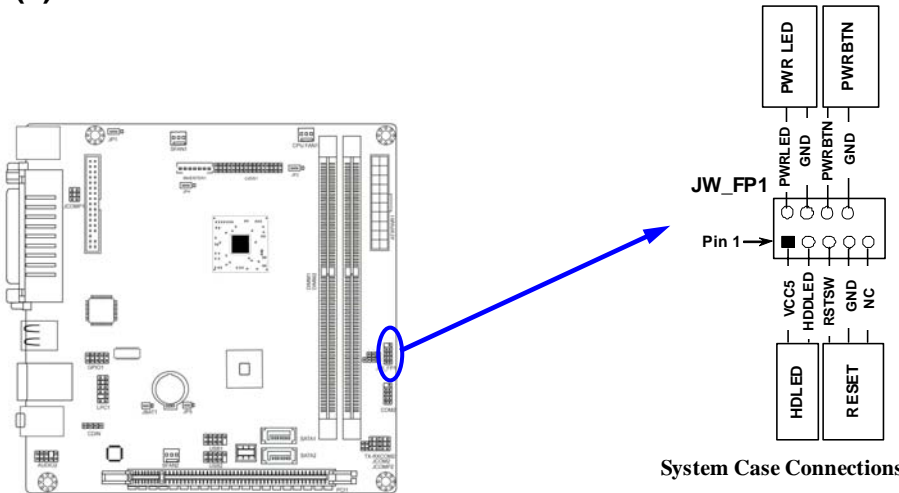

System Case Connections

(10) FAN Speed Headers (3-pin): CPUFAN1, SFAN1/SFAN2

Pin1: GND

Pin2: +12V fan power

Pin3: Fan Speed

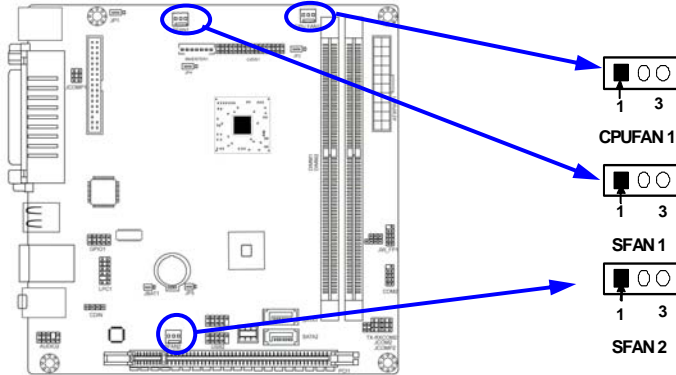

(11) GPIO Header (10-pin): GPIO1

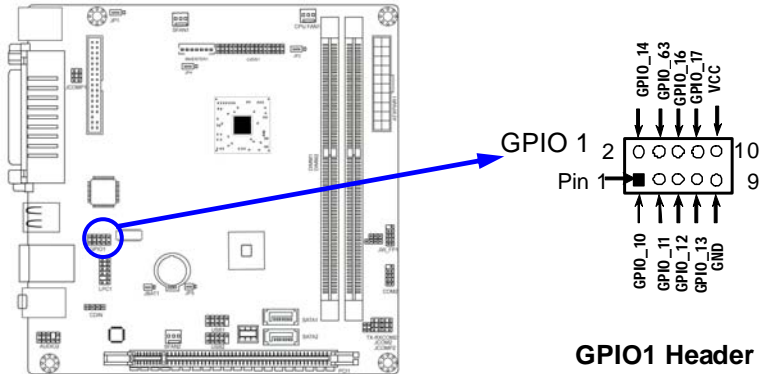

GPIO1 Header

(12) LPC Header (11-pin): LPC1

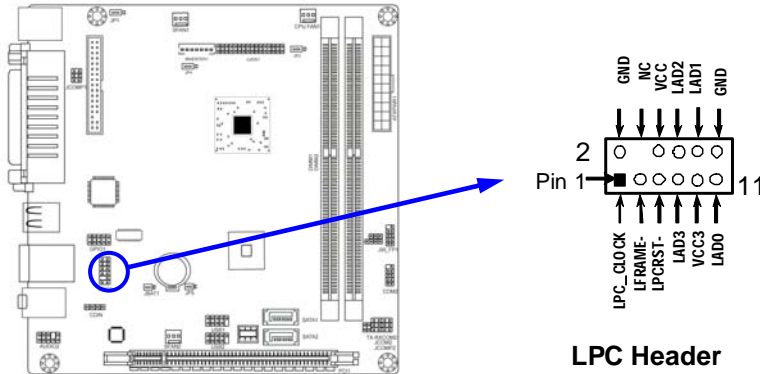

LPC Header

Chapter 3

Introducing BIOS

Notice! The BIOS options in this manual are for reference only. Different configurations may lead to difference in BIOS screen and BIOS screens in manuals are usually the first BIOS version when the board is released and may be different from your purchased motherboard. Users are welcome to download the latest BIOS version form our official website.

The BIOS is a program located on a Flash Memory on the motherboard. This program is a bridge between motherboard and operating system. When you start the computer, the BIOS program will gain control. The BIOS first operates an auto-diagnostic test called POST (power on self test) for all the necessary hardware, it detects the entire hardware device and configures the parameters of the hardware synchronization. Only when these tasks are completed done it gives up control of the computer to operating system (OS). Since the BIOS is the only channel for hardware and software to communicate, it is the key factor for system stability, and in ensuring that your system performance as its best.

In the BIOS Setup main menu of Figure 3-1, you can see several options. We will explain these options step by step in the following pages of this chapter, but let us first see a short description of the function keys you may use here:

- Press <Esc> to quit the BIOS Setup.
- Press ↑↓←→ (up, down, left, right) to choose, in the main menu, the option you want to confirm or to modify.
- Press <F10> when you have completed the setup of BIOS parameters to save these parameters and to exit the BIOS Setup menu.
- Press Page Up/Page Down or +/- keys when you want to modify the BIOS parameters for the active option.

3-1 Entering Setup

Power on the computer and by pressing immediately allows you to enter Setup. If the message disappears before you respond and you still wish to enter Setup, restart the system to try again by turning it OFF then ON or pressing the “RESET” button on the system case. You may also restart by simultaneously pressing <Ctrl>, <Alt> and <Delete> keys. If you do not press the keys at the correct time and the system does not boot, an error message will be displayed and you will again be asked to

Press to enter Setup

3-2 Getting Help

Main Menu

The on-line description of the highlighted setup function is displayed at the bottom of the screen.

Status Page Setup Menu/Option Page Setup Menu

Press F1 to pop up a small help window that describes the appropriate keys to use and the possible selections for the highlighted item. To exit the Help Window, press <Esc>.

3-3 The Main Menu

Once you enter AMI ® BIOS CMOS Setup Utility, the Main Menu (Figure 3-1) will appear on the screen. The Main Menu allows you to select from fourteen setup functions and two exit choices. Use arrow keys to select among the items and press <Enter> to accept or enter the sub-menu.

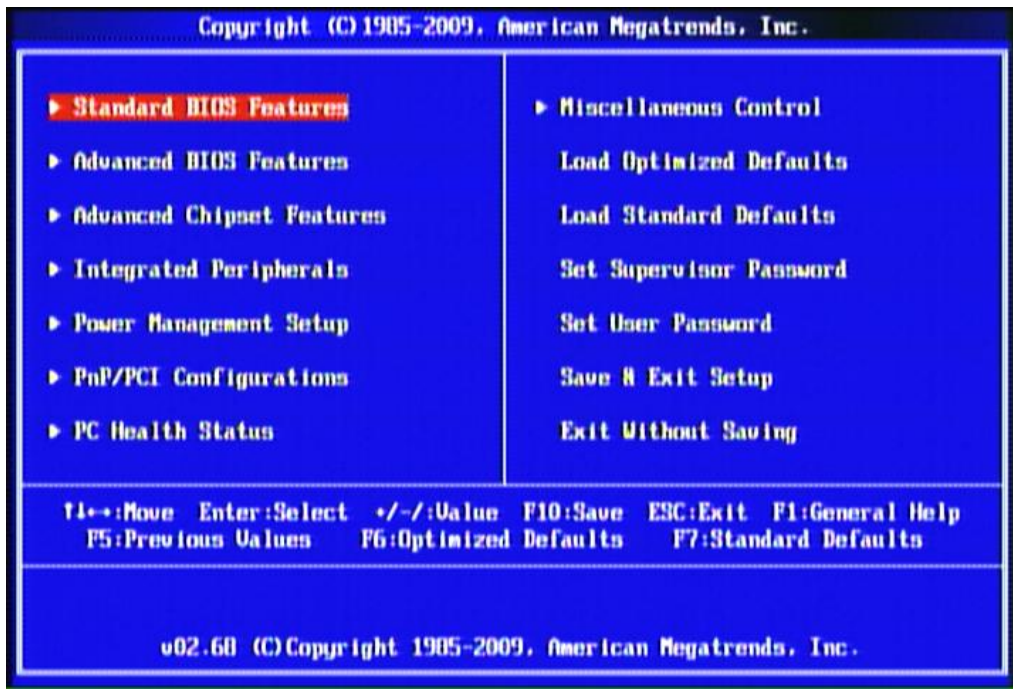

Figure 3-1

Standard BIOS Features

Use this Menu for basic system configurations.

Advanced BIOS Features

Use this menu to set the Advanced Features available on your system.

Advanced Chipset Features

Use this menu to change the values in the chipset registers and optimize your system's performance.

Integrated Peripherals

Use this menu to specify your settings for integrated peripherals.

Power Management Setup

Use this menu to specify your settings for power management.

PnP/PCI Configurations

Use this menu to specify your settings for PnP and PCI configurations.

PC Health Status

This entry shows your PC health status.

Miscellaneous Control

Use this menu to specify your settings for Miscellaneous Control.

Load Optimized Defaults

Use this menu to load the BIOS default values these are setting for optimal performances system operations for performance use.

Load Standard Defaults

Use this menu to load the BIOS default values for the minimal/stable performance system operation

Set Supervisor Password

Use this menu to set supervisor password.

Set User Password

Use this menu to set user password.

Save & Exit Setup

Save CMOS value changes to CMOS and exit setup.

Exit Without Saving

Abandon all CMOS value changes and exit setup.

3-4 Standard BIOS Features

The items in Standard CMOS Setup Menu are divided into several categories. Each category includes no, one or more than one setup items. Use the arrow keys to highlight the item and then use the <PgUp> or <PgDn> keys to select the value you want in each item.

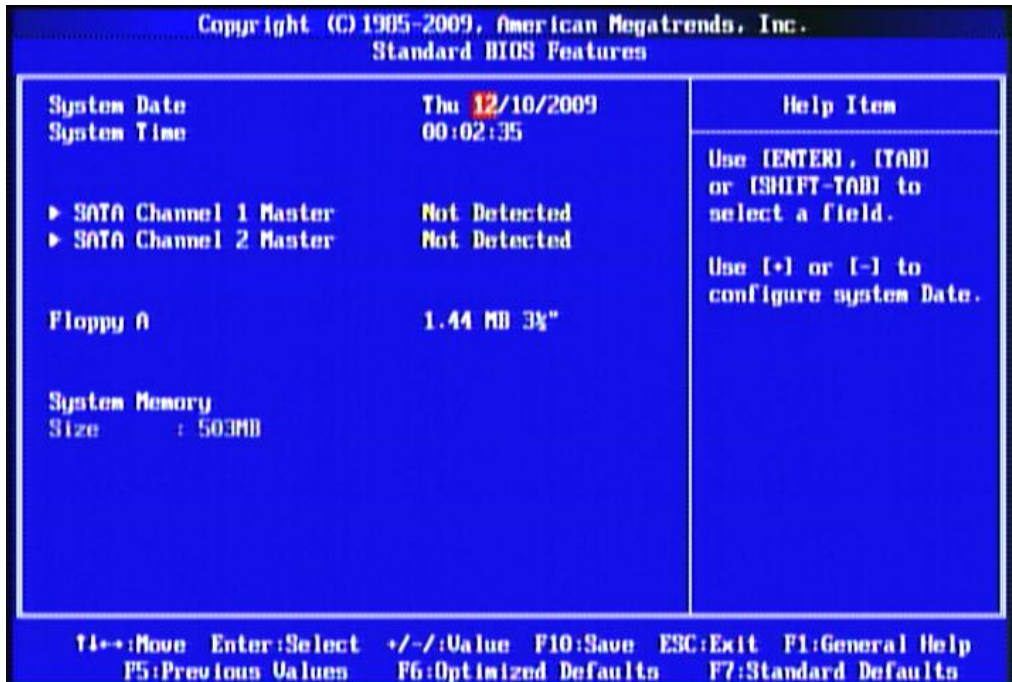

Date

The date format is <day><month><date><year>.

Day Day of the week is from Sun to Sat, determined by BIOS. Read-only.

Month The month is from Jan. through Dec.

Date The date from 1 to 31 can be keyed by numeric function keys.

Year The year depends on the year of the BIOS.

Time

The time format is <hour><minute><second>.

SATA Channel 1/2 Master

While entering setup, BIOS auto detects the presence of IDE devices. This displays the status of auto detection of IDE devices.

Type: The optional settings are: Not Installed; Auto; CD/DVD and ARMD

LBA/Large Mode: The optional settings are Auto; Disabled.

Disabled: disables LBA mode.

Auto: enables LBA Mode if the devices support it and the device is not already formatted with LBA Mode disabled.

Block (Multi-Sector Transfer): The optional settings are: Disabled and Auto.

Disabled: The Data transfer from and to the device occurs one sector at a time.

Auto: The Data transfer from and to the device occurs multiple sectors at a time if the device supports it.

PIO Mode: the optional settings are: Auto, 0, 1, 2, 3 and 4.

DMA MODE: the optional settings are Auto, SWDMAn, MWDMAAn, UDMAN.

S.M.A.R.T.: This option allows you to enable the HDD S.M.A.R.T Capability (Self-Monitoring, Analysis and Reporting Technology). The optional settings are Auto; Disabled; and Eabled.

32 Bit Data Transfer: the optional settings are: Disabled and Enabled.

Floppy A

This item is for specific floppy disk drive settings. Select according to the specification of the floppy disk you use.

3-5 Advanced BIOS Features

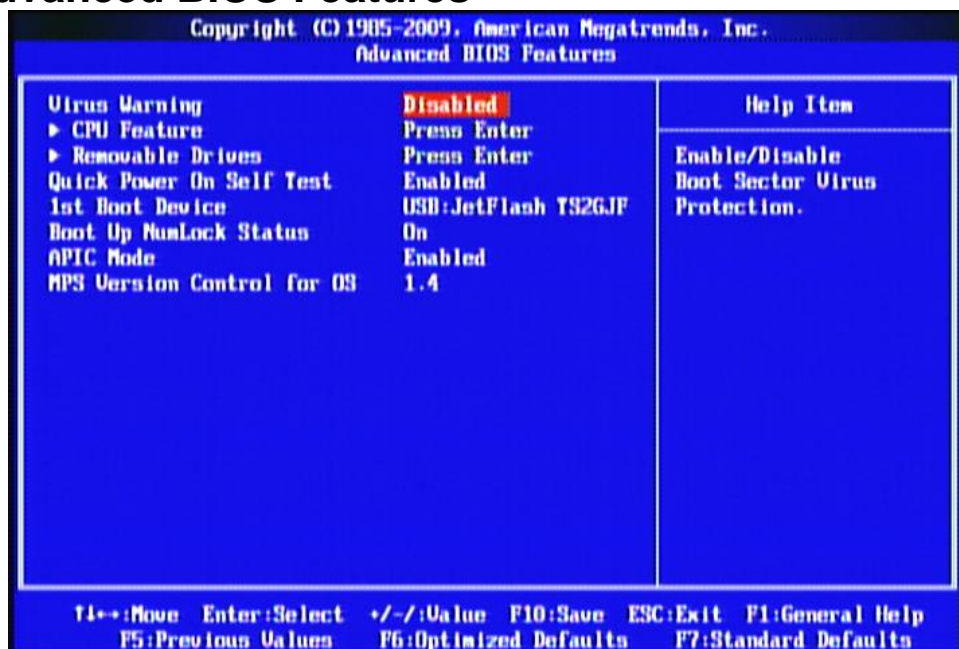

Virus Warning

The selection Allow you to choose the VIRUS Warning feature for IDE Hard Disk boot sector protection. If this function is enabled and someone attempt to write data into this area, BIOS will show a warning message on screen and alarm beep.

Disabled (default) No warning message to appear when anything attempts to access the boot sector or hard disk partition table.

Enabled Activates automatically when the system boots up causing a warning message to appear when anything attempts to access the boot sector of hard disk partition table.

Removable Drives

Use this item to specify the boot device priority sequence from available removable drives.

Quick Power On Self-Test

Allows BIOS to skip certain tests while booting. This will decrease the time needed to boot the system.

1st Boot Devices

Specify the boot sequence from the available devices. A device enclosed in parenthesis has been disabled in corresponding type menu.

Boot Up NumLock Status

The default value is On.

On (default) Keypad is numeric keys.

Off Keypad is arrow keys.

MPS Version Control for OS

This option is only valid for multiprocessor motherboards as it specifies the version of The Multiprocessor Specification (MPS) that the motherboard will use.

3-5-1 CPU Feature

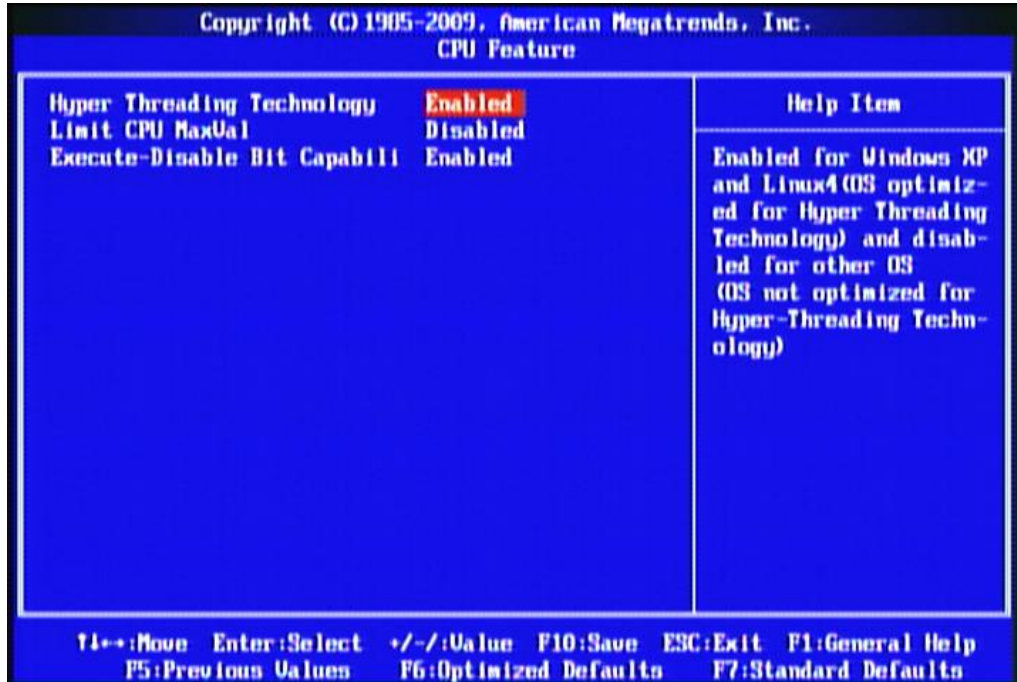

Hyper-Threading Technology

Enabled for Windows XP and Linux4 (OS optimized for Hyper-Threading Technology) and disabled for other OS (OS not optimized for Hyper-Threading Technology)

Limit CPU MaxUal

The optional settings are: Disabled; Enabled.

Execute-Disable Bit Capabil1

The optional settings are: Disabled; Enabled. When disabled, force the XD feature flag to always return 0.

3-6 Advanced Chipset Features

The Advanced Chipset Features Setup option is used to change the values of the chipset registers. These registers control most of the system options in the computer.

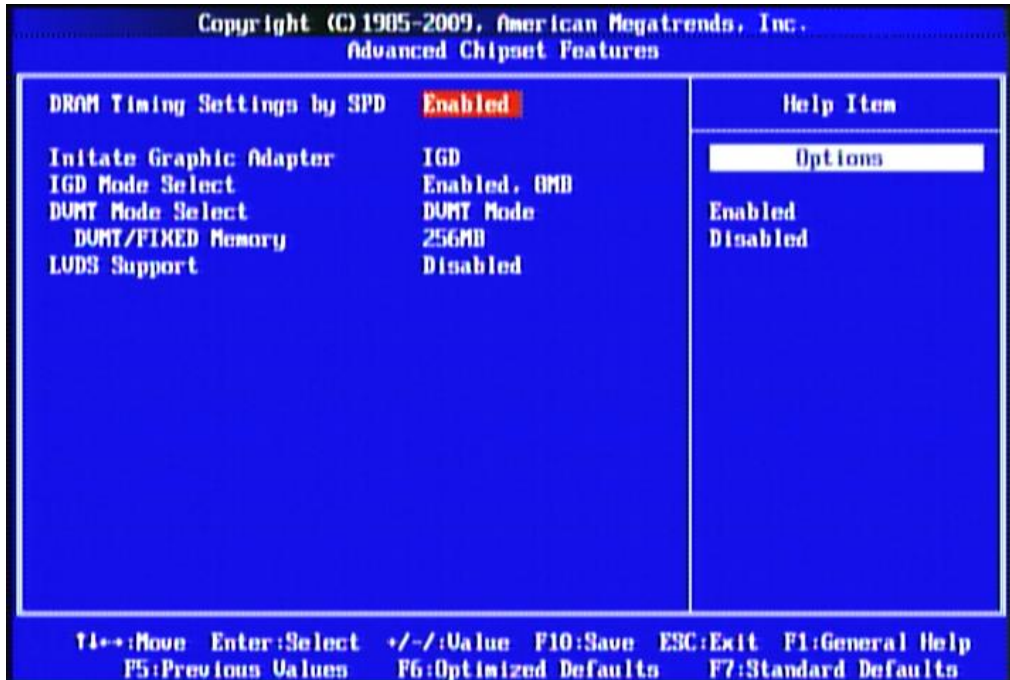

DRAM Timing Settings by SPD

The optional settings are: Disabled; Enabled.

Initiate Graphic Adapter

The optional settings are: 1GD; PCIE/IGD. Select which graphic controller to use as the primary boot device.

1GD Mode Select

The optional settings are: Disabled; Enabled, 4MB; Enabled, 8MB. Select the amount of system memory used by the Internal graphic device.

DVMT/FIXED Memory

The optional values are: 128MB; 256 MB; Maximum DVMT.

LVDS Support

The optional settings are: Disabled; Enabled.

3-7 Integrated Peripherals

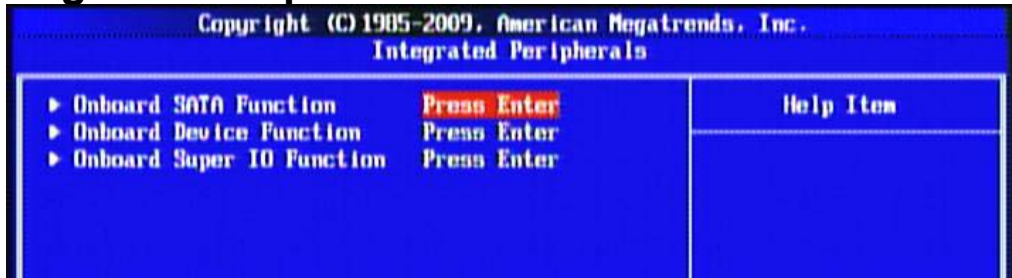

3-7-1 Onboard SATA Function

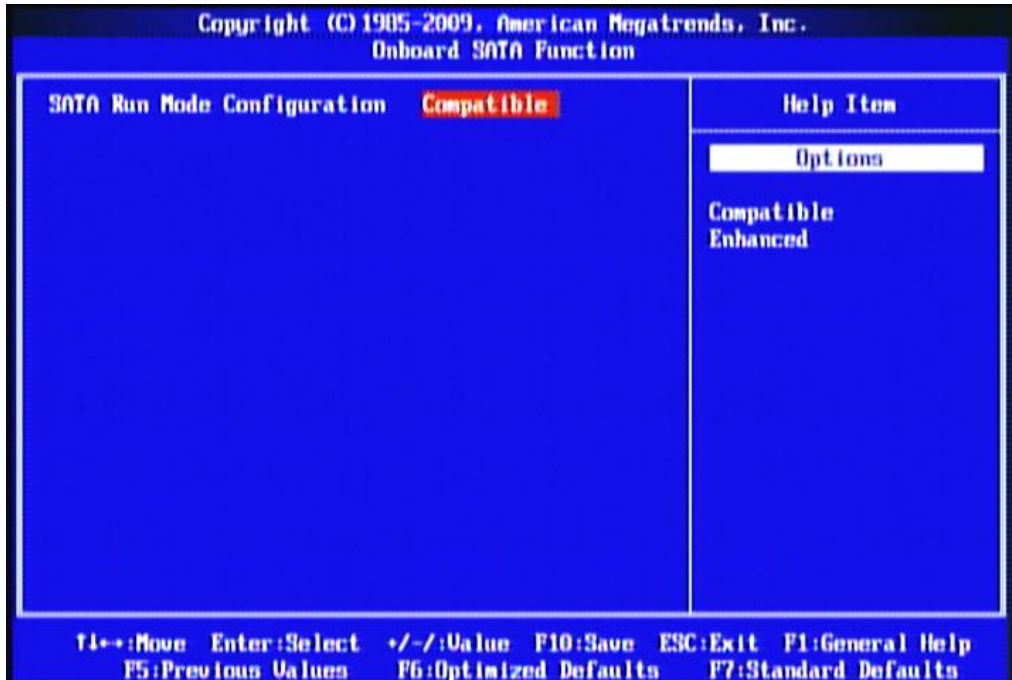

SATA Run Mode Configuration

The optional settings are: Compatible; Enhanced.

3-7-2 Onboard Device Function

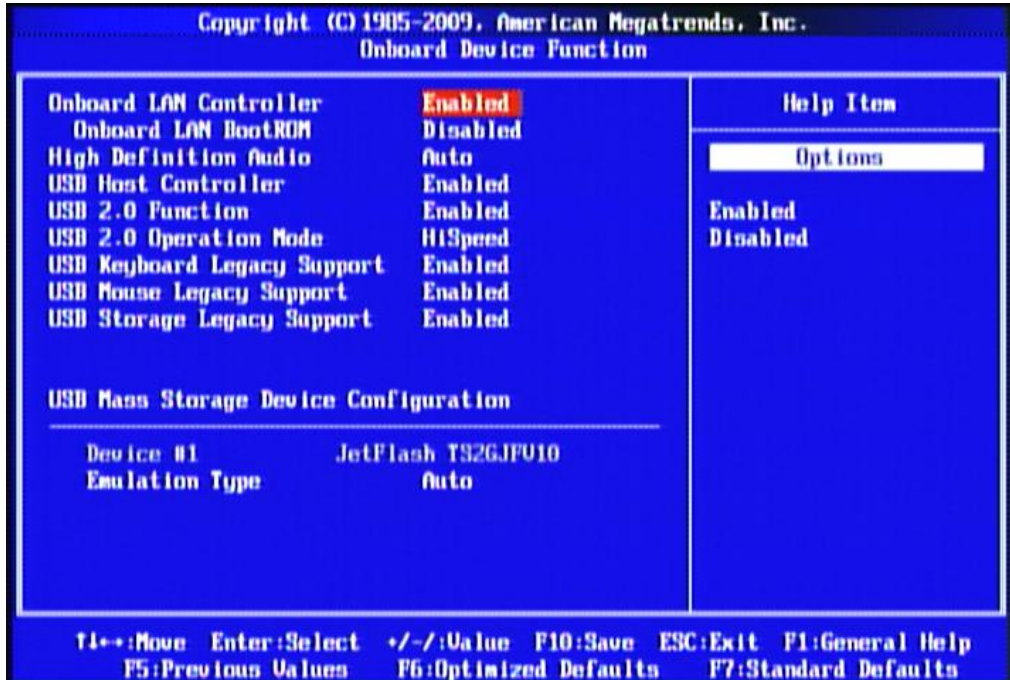

High Definition Audio

This item allows you to decide to auto /disable the chipset family to support HD Audio. The settings are: Auto, Disabled.

USB 2.0 Operation Mode

The settings are: FullSpeed; HiSpeed.

USB 2.0 Function / Keyboard Legacy/Mouse Legacy /Storage Legacy Support

Select enabled if your system contains a Universal Serial Bus (USB) controller and you have a USB mouse /keyboard/USB storage device. The settings are: Enabled, Disabled.

3-7-3 Onboard Super IO Function



OnBoard Floppy Controller

Use this item to allow BIOS to enable or disable Floppy Controller.

Serial Port 1/2 Address

The optional settings are: Disabled, 3F8/IRQ4, 3E8/IRQ4, 2E8/IRQ3.

Serial Port 2 Mode

The optional settings are: Normal, IrDA (1.6us), IrDA (3/16 bit)

Serial Port 2 RS485 Select

The optional settings are: Disabled(RS232); Enabled(RS485)

Parallel Port Address

Use this item to allow BIOS to select parallel port base addresses

The optional settings are: Disabled; 378; 288; 3BC

Parallel Port Mode

The optional settings are: Normal; Bi-Directional; ECP; EPP; ECP & EPP.

Watchdog Timer Select

This item is used to activate the watchdog function. The optional settings are: Enabled; Disabled.

3-8 Power Management Setup

The Power Management Setup allows you to configure your system to most effectively save energy saving while operating in a manner consistent with your own style of computer use.

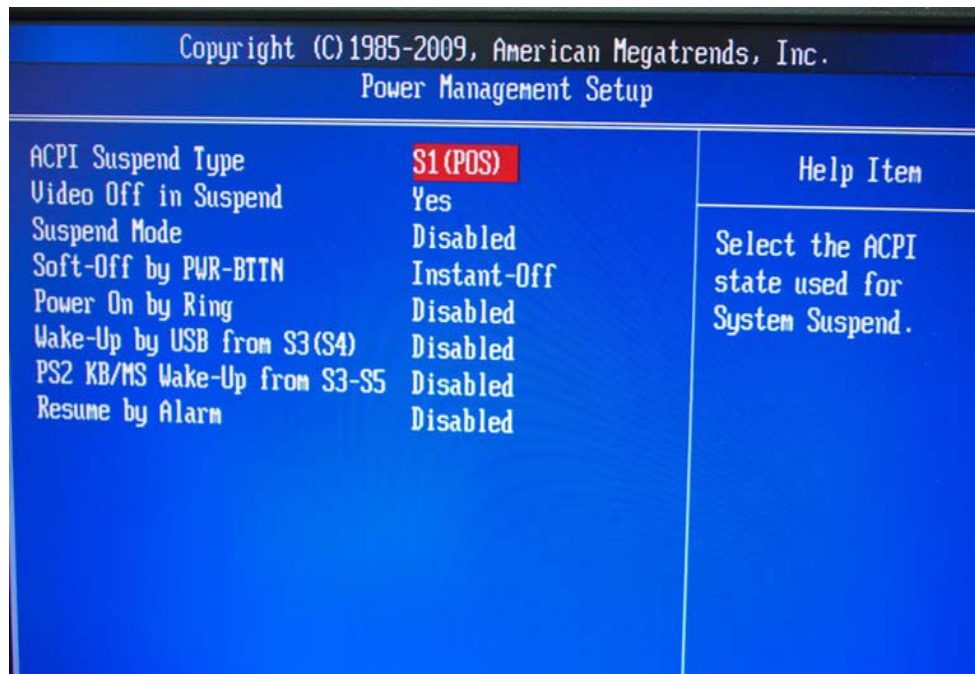

Video Off in Suspend

The optional settings are: No; Yes.

Suspend Mode

The optional settings are: Disabled;1Min;2 Min;4 Min;8 Min;10 Min;20 Min;30 Min;40 Min;50 Min;60 Min.

Soft-Off by PWR-BTTN

Under ACPI (Advanced Configuration and Power management Interface) you can create a software power down. In a software power down, the system can be resumed by Wake up Alarms. This item lets you install a software power down that is controlled by the power Button on your system. If the item is set to Instant-Off, then the power button causes a software power down. If the item is set to Delay 4 Sec, then you have to hold the power button down for four seconds to cause a software power down.

3-9 PnP/PCI Configurations



IRQ Resources

Names the interrupt request (IRQ) line assigned to the USB on your system. Activity of the selected IRQ always awakens the system.

PCI/VGA Palette Snoop

This item is designed to overcome problems that can be caused by some non-standard VGA cards. This board includes a built-in VGA system that does not require palette snooping so you must leave this item disabled.

3-10 PC Health Status

This section shows the Status of you CPU, Fan, and Warning for overall system status. This is only available if there is Hardware Monitor onboard.

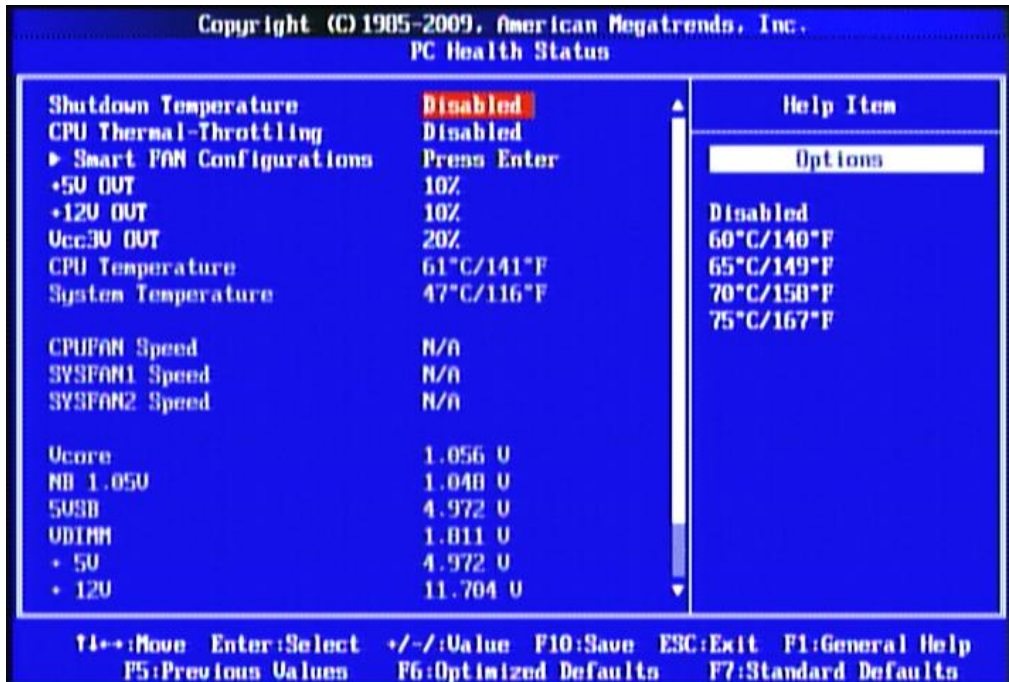

Shutdown Temperature

This item can let users setting the Shutdown temperature, when CPU temperature over this setting the system will auto shutdown to protect CPU.

CPU Thermal Throttling

The optional settings are: Disabled; Enabled. When it is set as Enabled user could set value for CPU Thermal-Throttling Temp.; CPU Thermal-Throttling Duty and CPU Thermal-Throttling Beep.

Smart Fan Configuration

Press Enter to set certain values for the following three items: CPUFAN Smart Mode; SYSFAN1 Smart Mode; SYSFAN2 Smart Mode.

5V OUT/12V OUT/Vcc3V OUT/Vcore/ /NB1.05V/5V/12V/5 USB/VDIMM/ / CPU Temperature/ System Temperature/CPUFAN/ SYSFAN1/SYSFAN2 Speed

This will show the CPU/FAN/System voltage chart and FAN Speed, etc.

3-11 Miscellaneous Control

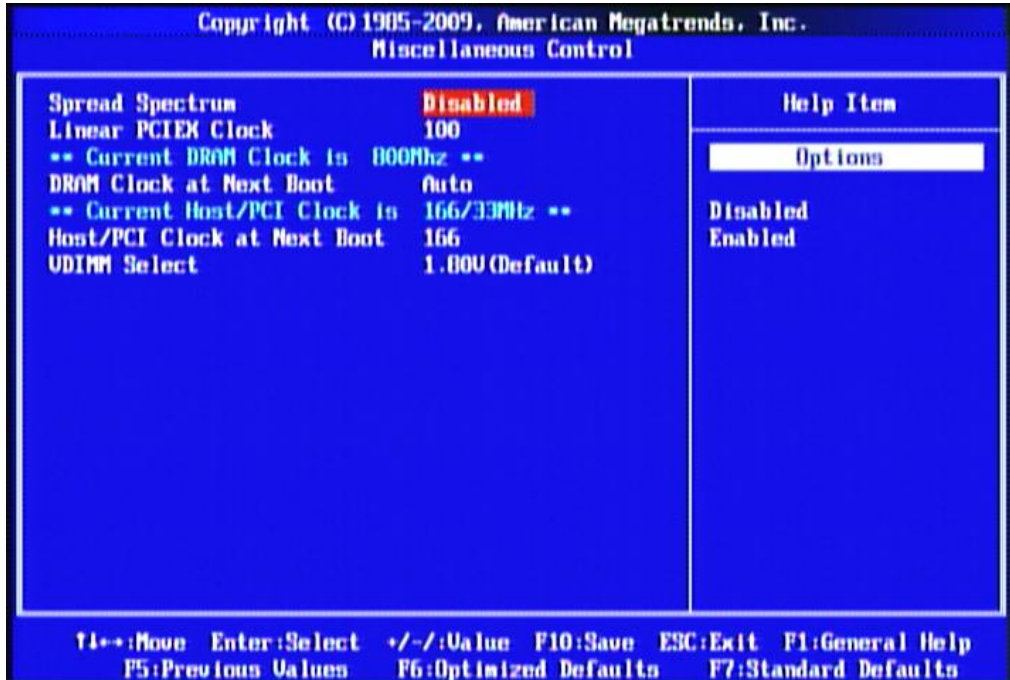

Spread Spectrum

The optional settings are: Enabled; Disabled.

DRAM Clock at Next Boot

This item allows you to set DRAM clock. The optional settings are: Auto; 667MHz; 800MHz

VDIMM Select

The optional settings are: 1.80v (Default); 1.90v; 1.95v; 2.00v.

3-12 Password Setting

You can set either supervisor or user password, or both of them. The differences are:

Supervisor password: Can enter and change the options of the setup menus.

User password: Can only enter but do not have the right to change the options of the setup menus. When you select this function, the following message will appear at the center of the screen to assist you in creating a password.

ENTER PASSWORD:

Type the password, up to eight characters in length, and press <Enter>. The password typed now will clear any previously entered password from CMOS memory. You will be asked to confirm the password. Type the password again and press <Enter>. You may also press <Esc> to abort the selection and not enter a password. To disable a password, just press <Enter> when you are prompted to enter the password. A message will confirm that the password will be disabled. Once the password is disabled, the system will boot and you can enter Setup freely.

PASSWORD DISABLED.

When a password has been enabled, you will be prompted to enter it every time you try to enter Setup. This prevents an unauthorized person from changing any part of your system configuration.

Additionally, when a password is enabled, you can also require the BIOS to request a password every time your system is rebooted. This would prevent unauthorized use of your computer.

You determine when the password is required within the BIOS Features Setup Menu and its Security option. If the Security option is set to "System", the password will be required both at boot and at entry to Setup. If set to "Setup", prompting only occurs when trying to enter Setup.

3-13 Load Optimized /Standard Defaults

Load Optimized Defaults

When you press <Enter> on this item, you get a confirmation dialog box with a message similar to:

```
Load Optimized Defaults?  
【OK】      【Cancel】
```

Pressing <OK> loads the default values that are factory settings for optimal performance system operations.

Load Standard Defaults

When you press <Enter> on this item, you get a confirmation dialog box with a message similar to:

```
Load Standard Defaults?  
【OK】      【Cancel】
```

Pressing <OK> loads the default values that are factory settings for stable performance system operations.

3-14 Save and Exit Setup/ Exit Without Saving

Save and Exit Setup

When you press <Enter> on this item, you get a confirmation dialog box with a message similar to:

```
Save configuration changes and exit setup?  
【OK】      【Cancel】
```

Pressing <OK> save the values you made previously and exit BIOS setup.

Exit Without Saving

When you press <Enter> on this item, you get a confirmation dialog box with a message similar to:

```
Discard Changes and Exit Setup?  
【OK】      【Cancel】
```

Pressing <OK> to leave BIOS setting without saving previously set values.