



user's manual

UniStream

model #: BD01

Universal Bluetooth® Music Dock

hello.

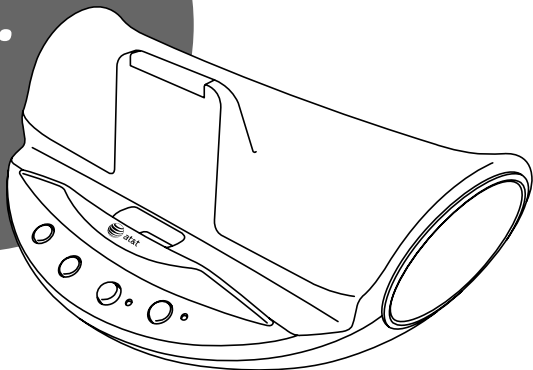

Thank you for purchasing
UniStream [BD01].

Universal Bluetooth® Music Dock

Features

- Bluetooth 2.1 with stereo A2DP
- ProTune Speaker system with Deep Bass Technology
- USB charging port to charge your media device
- Cable management system to keep wires organized
- Universal stand to securely dock most media devices
- Auxiliary input to play music from any device with a headphone jack

The Bluetooth® word mark and logos are registered trademarks owned by Bluetooth SIG, Inc.

What's Included

Unpack the music dock and make sure all accessories are put aside so they will not be lost.

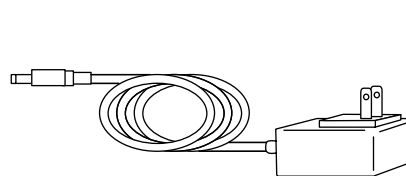

AC Adapter

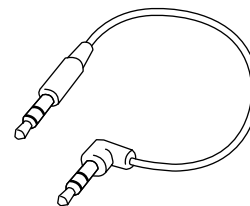

3.5mm Audio Cable

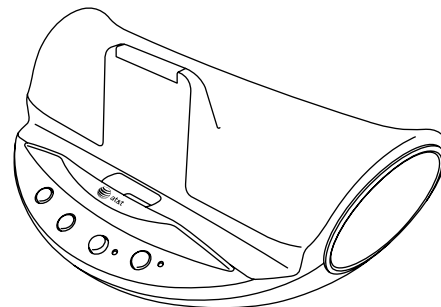

Music Dock

Contents

Introduction	2
What's Included	3
Safety Information	5
Getting Started	
Location of Main Unit Controls	8
Power Supply	9
Using the Audio Line in Connection	9
Operational Instructions	
Bluetooth Operation	10
Bass Boost Control	12
Charging Your Device	12
Troubleshooting	13
Compliance with FCC Regulations	14
Warranty Information	15
Specifications	17

Safety Information

Warning!

TO REDUCE THE RISK OF FIRE OR ELECTRIC SHOCK, DO NOT EXPOSE THIS APPLIANCE TO DRIPPING OR SPLASHING LIQUIDS.



The lightning flash and arrowhead symbol within the triangle is a warning sign alerting you of "dangerous voltage" inside the product.



WARNING: To reduce the risk of electric shock, do not remove cover (or back). No user-serviceable parts inside. Refer servicing to qualified service personnel.



The exclamation point within the triangle is a warning sign alerting you of important instructions accompanying the product.

NOTES: Caution symbols are printed on rear of music dock. Please refer to user's manual. This device complies with Part 15 of the FCC Rules. Operation is subject to the condition that this device does not cause harmful interference.

Important Safety Instructions

When used in the directed manner, this unit has been designed and manufactured to ensure your personal safety. However, improper use can result in potential electrical shock or fire hazards. Please read all safety and operating instructions carefully before installation and use, and keep these instructions handy for future reference. Take special note of all warnings listed in this user's manual and on the unit.

1. **CLEANING** - Unplug the unit from the wall outlet before cleaning. Clean the unit using a damp cloth; do not use liquid or aerosol cleaners.
2. **ATTACHMENTS** - Do not use attachments not recommended by the manufacturer.
3. **ANTENNA** - Do not connect an external antenna to the unit (other than that provided).
4. **WATER AND MOISTURE** - The unit should not be used near water. For example: near a bathtub, washbowl, kitchen sink, laundry tub, swimming pool or in a wet basement.
5. **PLACEMENT** - Do not place the unit on an unstable table, stand, tripod, or bracket. This may result in serious personal injuries and damage to the unit.
6. **VENTILATION** - The unit should be situated so that its location or position does not interfere with its proper ventilation. For example, it should not be situated on a bed, sofa, rug or similar surface that may block ventilation openings. Also, it should not be placed in a built-in installation, such as a bookcase or cabinet, which may impede the flow of air through the ventilation openings.
7. **PERIODS OF NON-USE** - If the unit is to be left unused for an extended period of time, such as a month or longer, the power cable should be unplugged from the unit to prevent damage or corrosion.
8. **OBJECTS AND LIQUID ENTRY** - Care should be taken so that external objects do not fall into and liquids are not spilled onto any openings or vents located on the product.

9. **POWER SOURCE** - The unit should be connected to a power supply only of the type described in the operating instructions or as marked on the unit. If you are not sure, please consult the dealer or local power company.
10. **POWER CORD PROTECTION** - Power supply cord should be routed so that it is not likely to be walked on or pinched by items placed upon or against them. It is always better to have a clear area from where the cable exits the unit to where it is plugged into an AC outlet.
11. **LIGHTNING** - Unplug the unit from the wall outlet and disconnect the antenna or cable system during a lightning storm or when it is left unattended and unused for long periods of time. This will prevent damage to the product due to lightning and power-line surges.
12. **OVERLOADING** - Do not overload wall outlets, extension cords, or integral convenience receptacles as this can result in a risk of fire or electric shock.
13. **HEAT** - The unit should be situated away from heat sources such as radiators, heat registers, stoves or other appliances (including amplifiers) that produce heat.
14. **DAMAGE REQUIRING SERVICE** - The unit should be serviced by qualified service personnel when:
 - A. the power supply cable or plug has been damaged.
 - B. objects have fallen into or liquid has been spilled onto the enclosure.
 - C. the unit has been exposed to rain.
 - D. the unit has been dropped or the enclosure damaged.
 - E. the unit exhibits a marked change in performance or does not operate normally.
15. **SERVICING** - The user should not attempt to service the unit beyond those methods described in the user's manual. Opening or removing covers will expose you to dangerous voltage and other hazards. Service methods not covered in the user's manual should be referred to qualified service personnel.
16. **SAFETY CHECK** - Upon completion of any service or repair to the unit, ask the service technician to perform safety checks to determine that the product is in proper working condition.

Location of Main Unit Controls

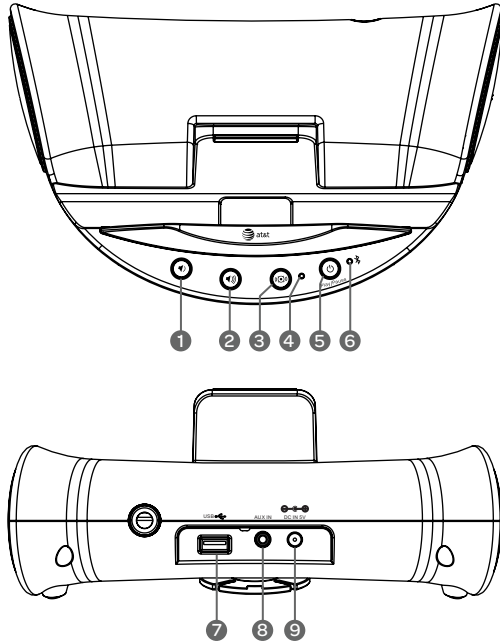

1. VOLUME - button
2. VOLUME + button
3. Bass Boost button
4. Bass Boost ON indicator
5. POWER ON/OFF/PLAY/PAUSE button
6. POWER/Bluetooth ON Indicator
7. USB Port
8. AUX IN Jack
9. DC IN Jack

Power Supply

AC Operation (External AC-DC Power Adapter)

- UniStream is equipped with a DC IN jack that should only be used with the supplied AC adapter to operate the music dock. Use of other adapters may damage the music dock or cause it to malfunction.
- Plug the tail end of the AC adapter into the DC IN jack (socket) on the rear of docking station.
- Insert the plug of the AC adapter into a wall outlet with AC power not controlled by a wall switch.

Powering ON/OFF

- Press the button to switch on the music dock.
- Press and hold button for 3 seconds to power off UniStream completely.

Using the Audio Line in Connection (AUX-INPUT)

- You can connect the audio output of an external device, such as a MP3 player or a TV, to UniStream for listening to the sound of that device through the high quality amplifier of the music dock.
- To connect the external device, use a standard stereo headphone (3.5 mm) cable to connect the "HEADPHONE-OUT" or "AUDIO LINE-OUT" of the device to the aux-in jack socket of this music dock.
- Switch on the music dock and the external device (eg. MP3-player or TV).
- UniStream will detect the 3.5 mm cable and automatically switch to AUX IN jack mode.
- Start playback of the external device and adjust the volume control of the docking station to the desired level.
- Remember to switch off the music dock when you are finished using the external device.

* Note: When a 3.5mm cable is connected to the auxiliary input on the docking station, Bluetooth® functionality is suspended. To resume Bluetooth® streaming, disconnect the 3.5mm cable from the auxiliary input.

Operational Instructions

Bluetooth Operation

Bluetooth Device Compatibility

UniStream connects with most Bluetooth devices that support the A2DP profile, including iPad/iPhone/iPod touch devices, and most smartphones, laptops and tablets.

Setting Up Your UniStream Music Dock for Pairing

1. Connect the AC power adapter cable to the DC IN jack, and plug the AC adapter into a power outlet not controlled by a wall switch.
2. Make sure there isn't a 3.5mm audio cable plugged into auxiliary input on the back of the docking station.
3. Press /Play/Pause button on the dock and it will automatically go into pairing mode.
4. The blue LED light will start to flash, indicating that UniStream is now ready to be paired with your Bluetooth device.

Pairing Bluetooth Device

1. Go to the Bluetooth Manager of your Bluetooth device.
2. Search Bluetooth devices and select ATT-BD01 to start connecting.
3. If your device asks for a PIN code, enter "0000".
4. Once paired, UniStream will beep and the blue LED light will flash rapidly 3 times.
5. Although UniStream can only stream audio from one device at a time, it is capable of being paired with up to eight devices.

Connecting a Paired Bluetooth Device

1. You will only need to pair your Bluetooth device with the dock one time.
2. The next time your Bluetooth device and the dock are in range of each other, and the Bluetooth feature is turned on, they will automatically connect.

Operational Instructions

3. The dock will only automatically connect to the last Bluetooth device it was connected to.
4. If your paired device does not automatically connect, navigate to the Bluetooth menu on your device and select ATT-BD01 from the list.

Note: Your UniStream can pair with and remember multiple Bluetooth devices, however it can only connect with one device at a time.

Playing Audio from Your Bluetooth Device

1. Once your media device is connected to the dock, simply start playing the music, movie or game and all the audio will automatically be played through UniStream.
2. Press ⏪/Play/Pause to play/pause the audio.
3. Press 🔊 or 🔇 to adjust the volume level of the dock.
4. Keep in mind that UniStream has up to a 30-foot Bluetooth wireless range.

Note: Your UniStream can pair with and remember multiple Bluetooth devices, however it can only connect with one device at a time.

Reconnecting Your Device

If you move out of range or turn off the Bluetooth feature on your device, the music dock will disconnect from your device. To reconnect, simply access the Bluetooth Manager on your device and select ATT-BD01. You will not be asked to enter the PIN code again.

Out of Range or Lost Signal

If the music device is out of range of the music dock or if there is something blocking the Bluetooth signal, the LED light will flash slowly to indicate that the Bluetooth connection with the music device has been lost.

To avoid a lost connection:

1. Move the music device back into range, and/or make sure there's a clear line of sight between the music dock and the Bluetooth device.
2. If the connection is lost, the connection will need to be reestablished. Follow the directions under "Reconnecting Your Device".

Operational Instructions

Bass Boost Control

Press the **Ⓞ** button on the front of the dock to increase the bass response. Press again to cancel the Bass Boost function.

Charging Your Device

The UniStream includes a USB port on the back to allow you to charge your media device. Make sure that UniStream is powered on and connect your device using the USB cable (not included). Your media device will begin to charge.

Note: Power output of the USB port is 500 mA. Media devices that require more power may not charge through this USB port.

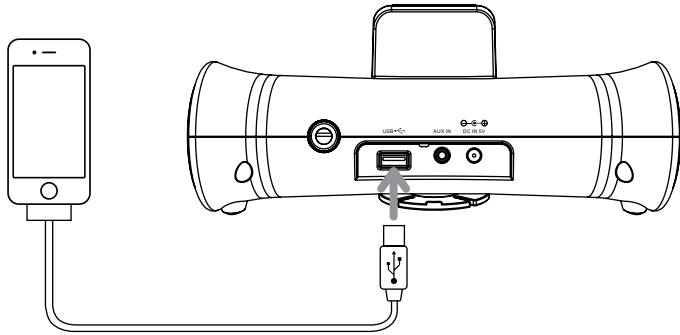

Troubleshooting

Symptom	Solution
Music is not streaming over Bluetooth	Make sure your Bluetooth device has A2DP profile. Check if both devices are paired and connected over Bluetooth. Make sure there isn't a 3.5mm cable connected to the aux input on the back of the speaker. Restart the UniStream to auto-connect with your Bluetooth device.
No power	Verify UniStream is plugged in properly and into a proper power source.
Music doesn't resume after hanging up a call	Press play to resume music.
No music control by UniStream	Make sure your Bluetooth device has AVRCP profile.

Remarks:

If troubleshooting does not eliminate the problem, disconnect the DC IN plug from the back of the music dock and reconnect it after a few seconds. This resets the music dock to its factory default settings and results in the deletion of all previous settings. In case the problem still exists, see warranty information on page 15 and page 16 to obtain service.

Compliance with FCC Regulations

The equipment has been tested and found to comply with the limits for a Class B digital device, pursuant to Part 15 of the FCC Rules. These limits are designed to provide reasonable protection against harmful interference in a residential installation. This equipment generates, uses, and can radiate Radio frequency energy and, if not installed and used in accordance with the instructions, may cause harmful interference to Radio communications.

However, there is no guarantee that interference will not occur in a particular installation. If this equipment does cause harmful interference to Radio or television reception, which can be determined by turning the equipment off and on, the user is encouraged to try to correct the interference by one or more of the following measures:

- Reorient or relocate the receiving antenna.
- Increase the separation between the equipment and receiver.
- Connect the equipment into an outlet on a circuit different from that to which the receiver is connected.
- Consult the dealer or an experienced Radio / television technician for assistance.

THE SPECIFICATION AND EXTERNAL APPEARANCE OF THE MUSIC DOCK ARE SUBJECT TO CHANGE WITHOUT PRIOR NOTICE.



If at any time in the future you should need to dispose of this product, please note that waste electrical products should not be disposed of with household waste. Please recycle where facilities exist. Check with your local authority or retailer for recycling advice.

Warranty Information

Limited Warranty

The AT&T brands are used under license. Any repair, replacement, or warranty service, and all questions about this product should be directed to Concept 101 LLC at www.att.com/electronics or call 1 (888) 920-8680 from the USA or Canada.

Concept 101 LLC warrants to the original purchaser that the product will be free from defects in material, parts and workmanship for the period designated for this product. The warranty commences the day the product is purchased and covers up to a period of one (1) year (90 day Labor and 1 year Parts). Concept 101 LLC agrees that it will, at its option, replace the defective product with either a new or remanufactured music dock equivalent to your original purchase during the warranty period. Should the Parts warranty period exceed the Labor warranty period, Concept 101 LLC will supply at no charge for the remainder of the Parts warranty, any new or remanufactured replacement parts as required by the product. During this period all labor and service charges will become the responsibility of the customer.

Exclusions: This warranty does not apply to the appearance or exterior of the product which may have been damaged or defaced, altered or modified in design or construction. This warranty does not apply if the serial number is altered or removed, or if there is any damage due to power line surge, user damage to the AC power cord, connection to improper voltage source, general misuse, accidents, or repair attempts by unauthorized service agents. Other exclusions include ear pads, rechargeable and non-rechargeable batteries.

Warranty Information

REPAIR OR REPLACEMENT AS PROVIDED UNDER THIS WARRANTY IS THE EXCLUSIVE REMEDY OF THE CUSTOMER; Concept 101 LLC SHALL NOT BE LIABLE FOR ANY INCIDENTAL OR CONSEQUENTIAL DAMAGES FOR BREACH OF ANY EXPRESS OR IMPLIED WARRANTY ON THIS PRODUCT, EXCEPT TO THE EXTENT PROHIBITED BY APPLICABLE LAW. ANY IMPLIED WARRANTY OF MERCHANTABILITY OF FITNESS FOR A PARTICULAR PURPOSE ON THIS PRODUCT IS LIMITED TO THE DURATION OF THE WARRANTY.

Some states do not allow the exclusion or limitations of incidental or consequential damages, or limitations on how long the warranty lasts. In these cases the above exclusions or limitations may not apply to you. This warranty gives you specific legal rights and you may also have other rights which vary from state to state.

Obtaining Service: To obtain service, product literature, supplies or accessories please call **1 888-920-8680**, or visit our website, www.att.com/electronics, to create a ticket for exchange/repair. Please make sure to provide the date of purchase, model number and a brief description of the problem. Our customer service representative will contact you or send detailed return instructions.

Concept 101 LLC does not warrant that the headset will work properly in all environmental conditions, and makes no warranty and representation, either implied or expressed, with respect to the quality, performance, merchantability, or fitness for a particular purpose other than the purpose identified within this user's manual. Concept 101 LLC has made every effort to ensure that this user's manual is accurate and disclaims liability for any inaccuracies or omissions that may have occurred. Information in this user's manual is subject to change without notice and does not represent a commitment on the part of Concept 101 LLC. Concept 101 LLC reserves the right to make improvements to this user's manual and/or to the products described in this user's manual at any time without notice. If you find information in this manual that is incorrect, misleading, or incomplete, please contact us through our website.

Specifications

- Power supply: DC 5V, 1.6Amps through built-in DC jack
External AC power adapter 100V-240V - 50/60Hz
- Speaker: Impedance 4 Ω 2.0" Speaker x2
- Amplifier: 3W x 2 THD 10%
- Bluetooth version 2.1
- Bluetooth compatibility: Bluetooth 2.0 or above device
with A2DP/AVRCP

purchase date:

place of purchase:



www.att.com/electronics

©2014 Concept 101 LLC. All Rights Reserved. AT&T and the AT&T logo are trademarks of AT&T Intellectual Property licensed to Concept 101 LLC, New York, New York 10018. Issue 7.0 AT&T 10/2014.