

Installation Guide

Flatpack2 Power Systems



Flatpack2 48V/24V 300A – 1200A Systems

Information in this document is subject to change without notice and does not represent a commitment on the part of *Eltek Valere*.

No part of this document may be reproduced or transmitted in any form or by any means—electronic or mechanical, including photocopying and recording—for any purpose without the explicit written permission of *Eltek Valere*.

Copyright © 2008 *Eltek Valere*



1303 E Arapaho Rd
Richardson, TX 75081
USA

Phone: +1 (469) 330-9100

Fax: +1 (469) 330-9101

Technical Support

+1 (866) 240-6614

www.eltekvalere.com

2046916 R1, June 2008

Published 17 June 2008

Table of Contents

1. Safety and Compliance	5
FCC Compliance Statement.....	5
2. Introduction	7
About This Guide	7
About This Revision (2)	7
3. Standard Systems	8
Flatpack2 -48V 300A	8
Flatpack2 -48V 600A and +24V 600A	8
Flatpack2 +24V 1200A.....	9
4. Mechanical Installation	10
System Unpacking.....	10
Rack Mounting	10
Rack Installation.....	10
Anchoring the Cabinet	11
Equipment Rack “Frame Ground”	11
Converter Shelf Installation.....	11
5. Electrical Installation	12
Individual Feed	13
Dual Feed	13
6. Module Installation	14
7. Distribution	15
Three-Bus Distributions	15
Designations	15
Bus Configurations for Single Distributions	16
Bus Configurations for Secondary Distributions	18
Breaker and Fuse Installation.....	21
Plug-in Breakers	23
Plug-in Fuse Holders.....	23
Device Installation and Extraction	24
Bulk Distributions	24
Bulk Battery Connections	24
Central Office Ground	27
Other Features and Options	27
Distribution Covers	27
Emergency Power-Off (EPO) and Service Bypass Switch	28
LVD Options.....	28

8. Alarm and Control Terminations	29
Alarm Contacts.....	29
Configurable Inputs	30
Temperature Probe Terminations	30
Symmetry Terminations.....	31
9. Controller Access.....	32
Controller Configurations.....	32
Smartpack Extended	32
Smartpack Extended with Slave	32
Smartpack Web	33
Smartpack Web with Slave.....	33
Smartpack with Controller Blank.....	33
Local Keypad Access	34
Local Computer Access.....	36
10. Startup Checklists.....	37

1. Safety and Compliance

WARNING: For safety, the power supply is required to be reliably connected to PROTECTIVE GROUND. The equipment is to be connected to supply mains by qualified personnel in accordance with local and national codes (e.g., NEC, CEC, etc). Do not disconnect and reconnect I/O power connectors during lightning storms. The output of the power supply is not intended to be accessible due to energy hazards. Rack mounting must be performed in accordance with instructions provided by the manufacturer to avoid potential hazards.

A readily accessible disconnect device shall be incorporated in the building installation wiring for all AC connections. Select wall breakers according to section AC input requirements (page 13).

FCC Compliance Statement

This device complies with Part 15 of FCC Rules. Operation is subject to the following two conditions:

1. This device may not cause harmful interference, and
2. This device must accept any interference received, including interference that may cause undesired operation.

WARNING: Changes or modifications to this unit not expressly approved by the party responsible for the compliance could void the user's authority to operate this equipment.

Protecting personnel against electrical shocks: The power system cabling must be done by qualified personnel in conformance with local and national electrical codes. Input voltages to rectifiers are at a dangerous level. Ensure that circuit breakers are locked in the OFF position at the AC service panel before attempting to work on the power system. Dangerous voltages may still be present at the terminals even if the rectifiers are OFF. Use a voltmeter to verify the presence of such voltages. Do not switch circuit breakers to ON until the entire system has been assembled and you have been instructed to do so according to the appropriate procedure. Improper wiring can cause bodily harm and equipment damage. Turn off all power sources before servicing units.

WARNUNG:

Schuetzen von Personal gegen elektrische Schocks. Die Spannungsversorgungs - Leitungen darf nur durch qualifiziertes Personal in Anpassung mit Oertlichen und nationalen elektrischen Codes ausgefuehrt werden. Unsachgemaesse Verdrahtung kann koerperliche Verletzung und Schaeden verursachen. Eingangsspannungen von der Netzspannungs - Versorgung Ihrer Hausanlage koennen unter Spannung stehen beim Anschluss der Leitungen. Versorgungsspannungen koennen bei unsachgemaessen Gebrauch gefaehrliche Schaeden verursachen. Sorgen Sie dafür,

dass die Cirquite Breaker in der aus position sind. Benutzen Sie ein Spannungsmesser um sicher zu sein das keine Netzspannung mehr vorhanden ist. Vergwissern Sie sich das alle Schalter an Ihrem Gereat und in der Vesorgung beim Anschluss abgeschaltet sind. Unsachgemaesse Verdrahtung kann koerperliche Verletzung und an der Ausstattung Schaeden verursachen. Vor Wartungsarbeiten am Gerät sind alle Netzkabel vom Stromnetz zu trennen, um die Gefahr eines elektrischen Schlages oder andere mögliche Gefahren zu reduzieren.

2. Introduction

The *Flatpack2* power system consists of 19" rectifier shelves, one or more *Smartpack* controllers, and a distribution section. It can be mounted in a standard 19" or 23" telecommunications equipment rack. Systems are available in 48VDC and 24VDC versions, with maximum outputs of 8kW to 32kW.

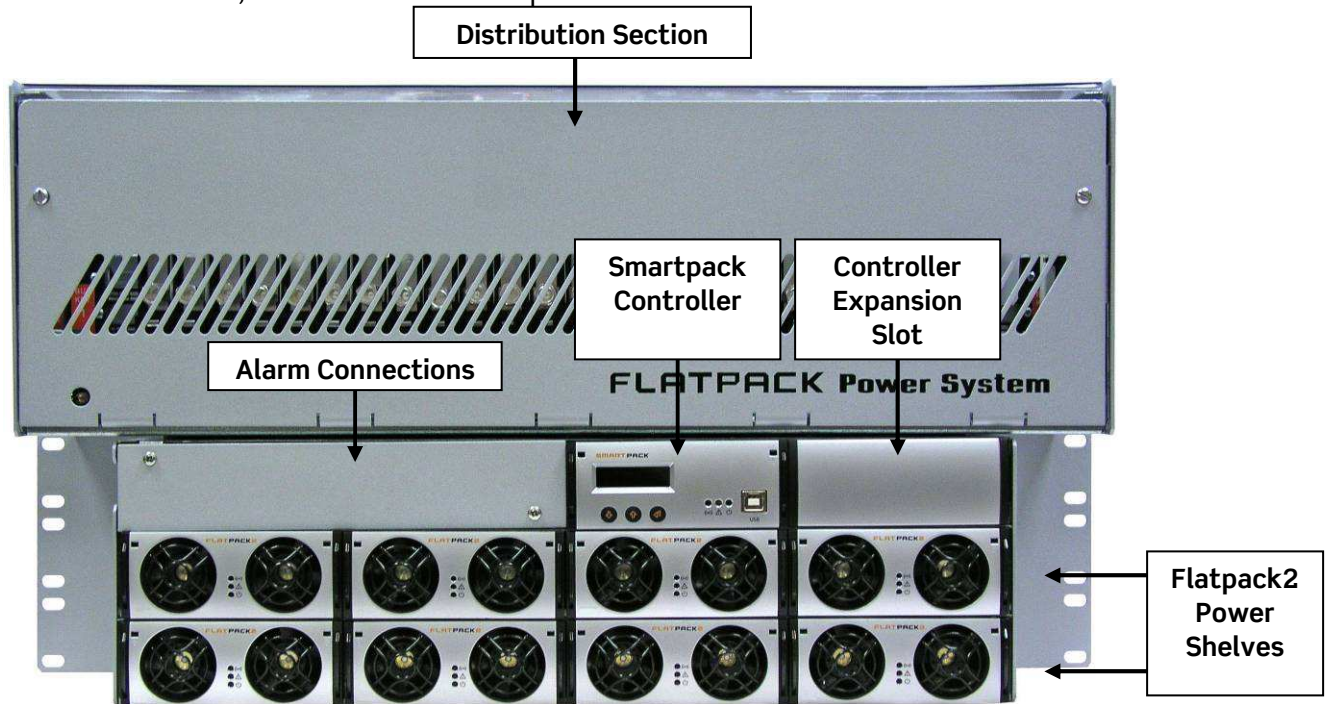

Figure 1 - Flatpack2 +24V 600A System

About This Guide

This manual provides a comprehensive overview of and installation guidelines for *Flatpack2* power systems with 300A to 1200A DC output. Additional information regarding system components is found in the following documents:

- 350002.013: User's Guide—*Flatpack2* Rectifiers
- 350003.013: User's Guide—*Smartpack* Monitoring & Control Unit

Information for the *Flatpack2* -48V 150A system and distribution configurations is contained in the following document:

- 2029242: Installation Guide—*Flatpack2* 150A DC System

About This Revision (2)

A new document format was adopted for this revision to reflect the transition to the *Eltek Valere* brand. In addition, information from individual *Flatpack2* system manuals was incorporated into this manual.

3. Standard Systems

Standard *Flatpack2* systems are defined by voltage and output current. As a general guideline, each larger system outputs about two times the current of the preceding system. The smallest system—*Flatpack2 -48V 150A*—is discussed in detail in another manual (#2029242) because of its unique and highly configurable 1U distribution section.

Flatpack2 -48V 300A

This system outputs a maximum of 14kW. It is designed for a 19" rack. There is room for a single *Smartpack* controller and up to seven *Flatpack2* rectifiers. The typical 19" distribution unit features twenty plug-in breaker positions and four bulk battery landings.



Figure 2 - Flatpack2 -48V 300A

Flatpack2 -48V 600A and +24V 600A

The -48V and +24V systems output a maximum of 32kW at -48V and 16kW at +24V. There is a dedicated 19" alarm and control section with room for up to two *Smartpack* controllers and alarm cards. These systems typically make use of the same 23"-wide, 4U-high distribution unit. This distribution features twenty-four plug-in breaker positions, eight bulk battery landings, an emergency power-off (EPO) circuit, and a service bypass switch.



Figure 3 - Flatpack -48V 600A



Figure 4 - Flatpack2 +24V 600A

Flatpack2 +24V 1200A

This system outputs a maximum of 32kW. It is designed for a 23" rack. The 23"-wide, 6U-high distribution unit features twenty-four plug-in breaker positions, eight bulk battery landings, room for up to two *Smartpack* controllers and alarm cards, an emergency power-off (EPO) circuit, and a service bypass switch.



Figure 5 - Flatpack2 +24V 1200A

4. Mechanical Installation



USE OF FULLY INSULATED TOOLS IS REQUIRED WHEN WORKING WITH ANY POWERED AC OR DC CIRCUITS.



THE SYSTEM IS TO BE MOUNTED OVER A CONCRETE SURFACE ONLY AND INSTALLED IN RESTRICTED ACCESS LOCATIONS (RAL). ACCESS MUST BE LIMITED BY USE OF TOOL, I.E. LOCK AND KEY.

The following tools are required for the installation:

- Standard wrench and/or socket set (1/4" to 1")
- Torque wrench, 10-40 Ft-lb range.
- Torque screwdriver, 5-10 in-lb range.
- Small flat blade screwdriver (3/32" wide)
- Standard blade screwdriver and Phillips tip screwdriver
- Wire cutters / strippers
- Fork-lift truck or similar heavy equipment handling transport
- Hoist with lifting straps
- Electric drill and appropriate bits (a hammer drill may be required for concrete flooring)

System Unpacking

An individual *Flatpack2* unit is typically pre-installed in a cabinet or rack, wrapped with a shroud of high-strength plastic, and bolted to a wooden pallet with four anchors. Rectifier modules and expansion options are packed in separate cartons. Exercise care when unpacking and setting the equipment in place.

Rack Mounting

Flatpack2 systems can be installed in a rack or an enclosure. The mounting brackets are pre-installed at the factory and designed to be mounted within a standard EIA 19" or 23" rack, depending on the width of the distribution box. Systems are designed to be mid-mounted. Other mounting configurations may require additional support brackets.

Rack Installation

- 1) Use proper lifting equipment to position the *Flatpack2* system so that the holes in the support bracket are aligned with the correct mounting holes in the rack.

- 2) Use rack screws to connect the system brackets to the desired positions of the rack.

Anchoring the Cabinet

If the system is delivered installed in a mounting rack, anchor the cabinet before installing rectifiers and batteries. Refer to the accompanying system installation guide for rack feet diagrams and floor loading concerns.

Equipment Rack “Frame Ground”

Connections are located at rear of the rectifier rack with chassis studs provided in the AC input chamber. Refer to the NEC and any local codes practices to determine the appropriate wire size. Use of paint-penetrating washers, abrasive compounds, or other means to achieve a reliable frame ground is recommended.

Converter Shelf Installation

If *Flatpack* DC-DC converters are to be installed, refer to the manual accompanying the converters for instructions on mounting and making system connections.

5. Electrical Installation



CAUTION: VERIFY THAT ALL AC CIRCUIT BREAKERS FEEDING THE SYSTEM ARE IN THE OFF POSITION. KEEP ALL AC BREAKERS OFF UNTIL ALL APPROPRIATE SYSTEM CONNECTIONS HAVE BEEN MADE AND VERIFIED. REFER TO SECTION 9 FOR STARTUP CHECKLISTS.



WARNING: FOR SAFETY REASONS (HIGH LEAKAGE CURRENT AND HIGH TOUCH CURRENT) ALWAYS CONNECT THE AC EARTH WIRE (PE) TO THE TERMINALS BEFORE CONNECTING AC INPUT CABLE(S).

Flatpack2 rectifiers have an operating input voltage range of 85 to 300 VAC (rated for 100 – 250 VAC), with a frequency range between 45 and 66 Hz. See the *User's Guide—Flatpack2 Rectifier Modules (350002.013)* for further details.



The AC junction box of each rectifier shelf contains a knockout hole for a standard trade-size conduit with a diameter of 0.75”.

To wire the AC input terminal block:

- 1) Remove the cover located at the rear of each rectifier shelf using a Phillips screwdriver (two screws).
- 2) Unscrew and remove the green AC connector using either a Phillips or flat blade screwdriver.
- 3) Use a small flat blade screwdriver to open each terminal and install AC wiring. See the sections “Individual Wiring” on page 13 and “Dual Feed” on page 13 for wiring details.
- 4) Pull a green safety wire in the AC mains conduit and terminate it to the ground terminal of the connector. It should be longer in length than the black and white AC wires.
- 5) Double-check that each connection is secure and replace the connector.

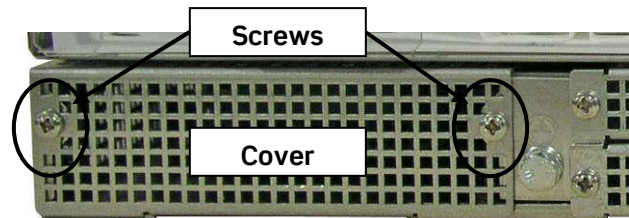

Figure 6 - AC Input Cover



Figure 7 - AC Terminal Block

6) If necessary, terminate additional safety wires to the shelf ground termination stud located to the right of the connector (see Figure 8 and Figure 9).

7) Replace the cover after AC terminations are complete. Make sure to line up the bottom plate between the guides on the bottom of the shelf.

Individual Feed

An individual feed shelf is fed by four (4) AC feeds; each feed supplies one rectifier. Systems operating at 48VDC and should have 15A breakers on each AC feed; 24VDC systems should have 20A breakers on each AC feed. #12 AWG wire is recommended, but up to #10 AWG may be used for each feed termination position. The figure below illustrates the 9-pin AC input connector. Termination points for Line 1, Line 2, and Ground are listed in the table at right.

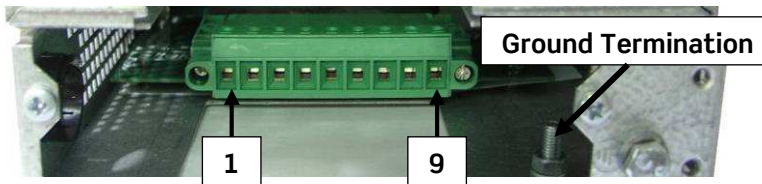

Figure 8 - Individual Feed Connector (Cover Removed)

Pin	Description
1	Line 1, Rectifier 1
2	Line 2, Rectifier 1
3	Line 1, Rectifier 2
4	Line 2, Rectifier 2
5	Line 1, Rectifier 3
6	Line 2, Rectifier 3
7	Line 1, Rectifier 4
8	Line 2, Rectifier 4
9	Ground

Dual Feed

A dual feed shelf is fed by two (2) AC feeds; each feed supplies two rectifiers. Systems operating at 48VDC and should have 30A breakers on each AC feed with #10 AWG wire; 24VDC systems should have 40A breakers on each AC feed with #8 AWG wire. The figure below illustrates the 5-pin AC input connector. Termination points for Line 1, Line 2, and Ground are listed in the table at right.

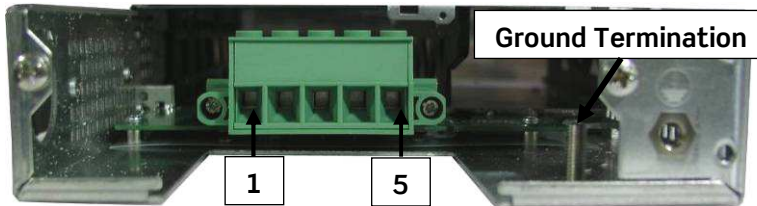

Figure 9 - Dual Feed Connector (Cover Removed)

Pin	Description
1	Line 2, Rectifier 1 & 2
2	Line 2, Rectifier 3 & 4
3	Line 1, Rectifier 1 & 2
4	Line 1, Rectifier 3 & 4
5	Ground

6. Module Installation



Device hazard

CAUTION:

- Do not carry modules by the handles, even if they are warm
- Open the handles **before** inserting modules into shelves



Flatpack2 rectifiers incorporate an AC mains fuse in each line.
Double Pole / Neutral Fusing

Both the *Smartpack* controller and the *Flatpack2* rectifier utilize the same locking mechanism to keep the module fixed in place when installed into a system shelf. Typically, the *Smartpack* controller is delivered installed in the system. If it is not pre-installed, make required connection to the back of the controller before installing (see Section 8).

To install modules:

- 1) Release the handles by inserting a small flat-blade screwdriver into the release slots and pressing the tip upward; extend each handle.
- 2) Slide the module firmly into the shelf.
- 3) Latch the handles to lock the rectifier in place.



To remove modules:

- 1) Release the handles by inserting a small flat-blade screwdriver into the release slots and pressing up.
- 2) Use the handles to pull the module out just far enough to where the body can be held.
- 3) Slide the module out the rest of the way. Do not carry it by the handles. *Flatpack2* rectifiers weigh just over 4 lbs (1.9 kg) each.

7. Distribution

Flatpack2 system distributions range in size from 19" to 23" in width and 4U to 6U in height. Although each distribution design is intended for a specific system configuration, distributions have inherent flexibility that permits them to work with all configurations. There are three primary designs defined by dimensions:

- 19" wide, 4U (7.0") high unit
- 23" wide, 4U (7.0") high unit
- 23" wide, 6U (10.5") high unit

Front views of these distributions and typical system configurations are found beginning on page 8. Rear views of the distributions are on page 26.

Three-Bus Distributions

The three-bus distribution features a unique, configurable design that allows load breakers and/or fuses to be aligned to any one of the three parallel, front-access buses (see Figure 10). Load landings accept up to #1 AWG cable with two-hole 1/4" lugs on 5/8" centers. Rear-access battery landings accept two-hole 3/8"-16 lugs on 1" centers; maximum wire gauge depends on the size of the distribution section.

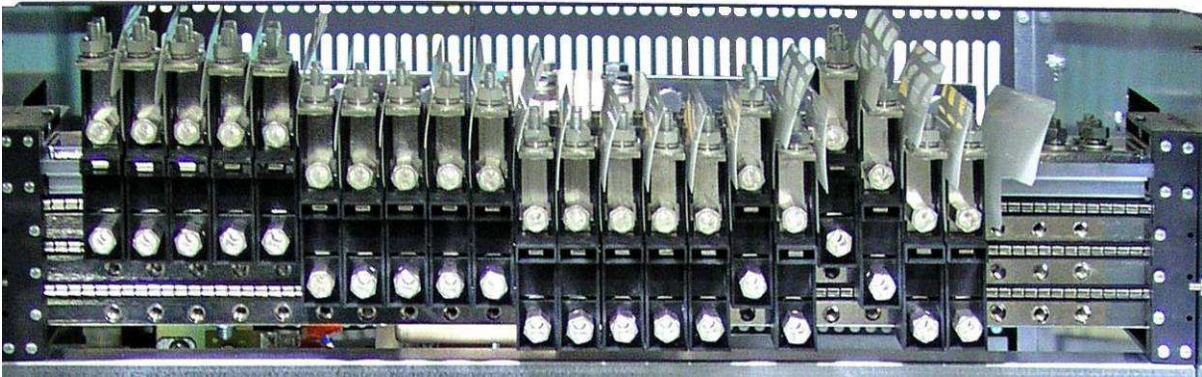

Figure 10 - Three-bus Distribution with Adjustable Distribution Device Holders

Designations

19" 4U

The 19" wide, 4U high distribution section is designed for 300A systems. The parallel load buses have **twenty** positions and holders for over-current protection devices. The rear of the distribution offers four bulk battery landings on each polarity, with each landing accepting a maximum wire size of 250 MCM.

23" 4U

The 23" wide, 4U high distribution section is designed for 600A systems. Load buses have **twenty-four** positions and holders for over-current protection devices. The rear of the distribution has eight bulk battery landings on each polarity accepting a maximum wire size of 250 MCM. An additional 4U distribution section can be added to double the number of cable landings for a total of forty-eight.

23" 6U

The 23" wide, 6U distribution section is designed for 1200A systems. Load buses have **twenty-four** positions and holders for over-current protection devices. Because each load bus is rated for 600A, two buses are strapped together to share the output current. The internal return bus is rated for the full 1200A. The rear of the distribution offers eight bulk battery landings on each polarity, with each landing accepting a maximum wire size of 750 MCM. An additional 4U distribution section can be added to double the number of cable landings for a total of forty-eight.

Bus Configurations for Single Distributions

Three-bus distributions can be configured in many ways. The following examples illustrate standard arrangements and some common variations. Notice that each diagram indicates the presence of a customer-supplied disconnect device between the system and batteries.

Standard Bus Configuration

The standard bus configuration is connected as shown. The bottom bus is the critical load termination point. During battery discharge the critical bus is fed from battery input through the low-voltage battery disconnect (LVBD) contactor. The contactor is designed to disconnect the battery from the system when it reaches a user-defined setpoint during discharge. The top bus is configured to accept battery input. Both the top bus and the rear bulk battery terminals are connected to the LVBD.

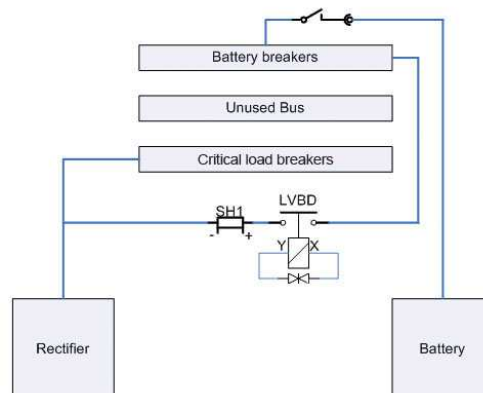

The 1200A system has a different configuration since each bus is rated at 600A; therefore, rectifier output must be divided between at least two buses. The top bus is unused in this configuration.

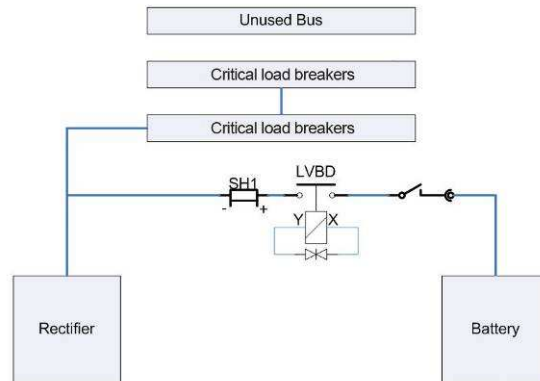

Load-Shedding Bus Configuration

The load-shedding bus configuration is connected as shown. The bottom bus is used for critical load termination points. The critical bus is intended for loads that need to have power for the longest available backup time. The critical bus is fed from the batteries through the low-voltage battery disconnect contactor. The secondary bus powers peripheral or redundant loads that can be shut down to increase available backup time. The secondary bus is fed through a low-voltage load disconnect contactor. The top bus is configured to accept battery input.

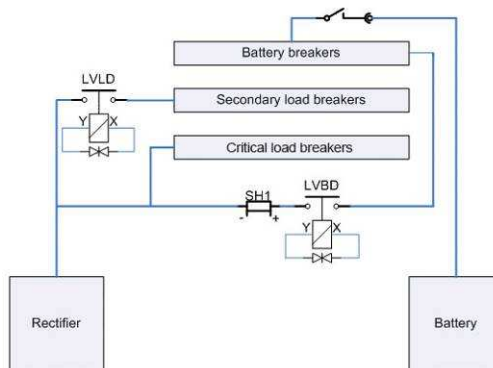

The 1200A system is very similar, except that the top bus is unused.

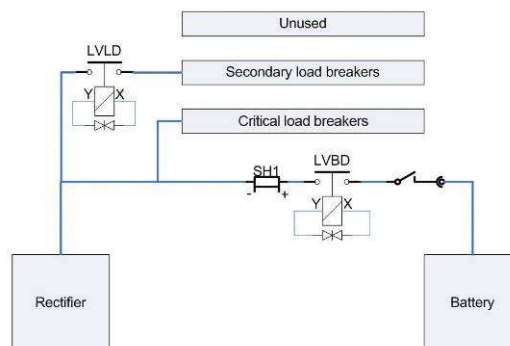

Converter Bus Configuration

The top bus can be used to distribute converter output. Converters are typically fed directly from the main bus on the same side of the LVBD contactor as other loads; this arrangement makes converters act as load to the native power of the DC system. Thus, the converter bus may continue powering dependent devices during an AC supply failure.

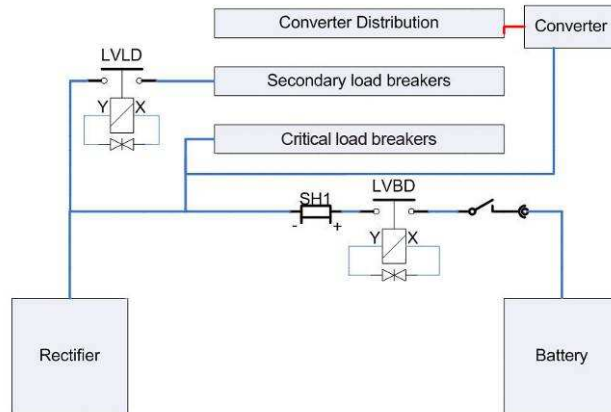

Bus Configurations for Secondary Distributions

A second distribution unit can be added atop 23" distributions to double the number of distribution positions from 24 to 48. The configuration of the second distribution panel typically mirrors the primary panel's configuration, unless indicated otherwise. Always verify the exact configuration prior to landing any connections. The following examples illustrate standard configurations and a common variation.

Standard Secondary Bus Configuration

The standard bus configuration for the 600A system uses the bottom bus for critical load termination points in both distribution panels. Each of the individual bus bars are rated at 600A, yielding a total distribution capacity of 1200A. The critical buses are fed through the low-voltage battery disconnect contactor. The LVBD contactor disconnects the battery from the system when it reaches a user-defined setpoint during discharge. The top bus of the bottom distribution section is configured to accept battery input; the top bus of the secondary distribution panel is not used. Load output for the secondary distribution panel is configured identically to the primary distribution panel.

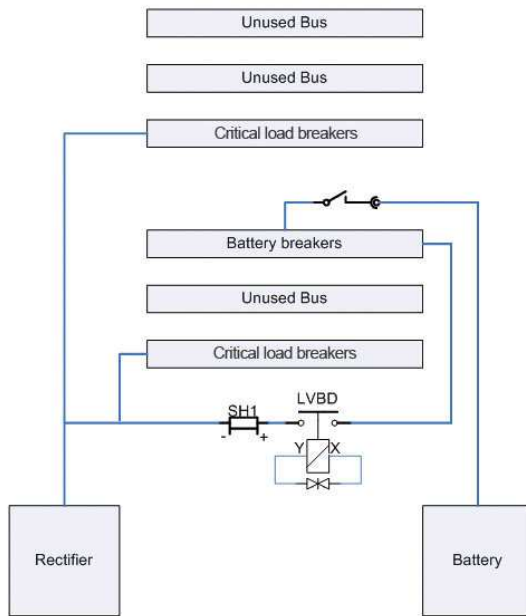

The 1200A system uses both the bottom bus and middle bus of each distribution section for critical load termination points, yielding a total distribution capacity of 2400A. The top buses are unused. Batteries may only connect to the rear bulk termination points.

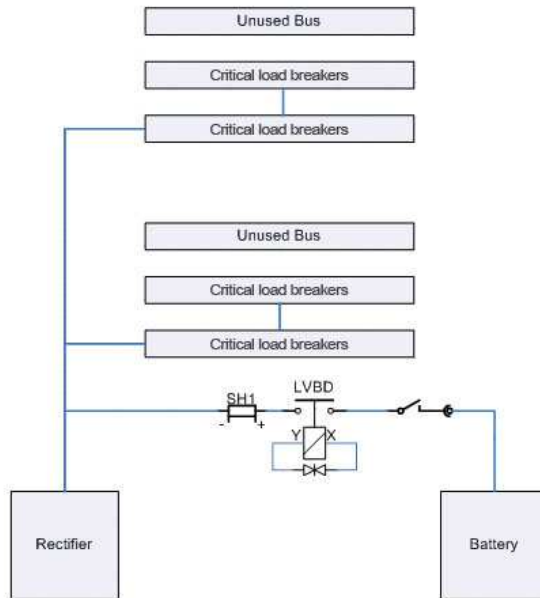

Load-shedding with Secondary Distribution

The load-shedding bus configuration for the 600A system with secondary distribution uses the bottom buses for critical loads that need the longest available backup time. Both critical buses are fed through the LVBD contactor. The middle buses are fed through an LVLD contactor and used for peripheral or redundant loads that can be shut down to increase available backup time. Each bus bar is rated at 600A for a total distribution capacity of 2400A. The top bus of the primary (bottom) distribution panel is configured to accept battery input; the corresponding bus in the secondary panel is unused. Load output for the secondary distribution is configured identically to the main section.

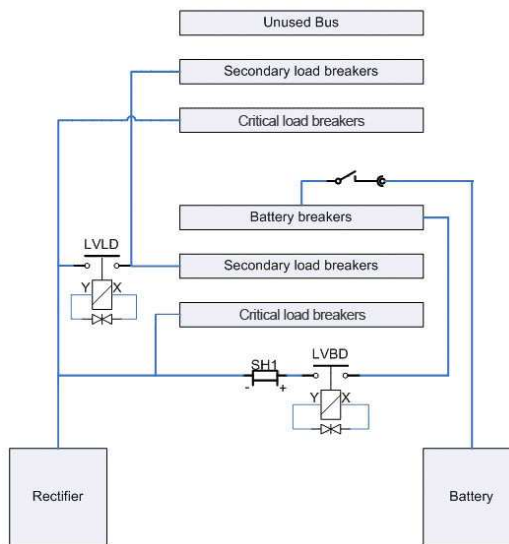

The 1200A system is similar to the 600A except for the top bus of the primary distribution section. Batteries can only connect through the rear bulk terminal points.

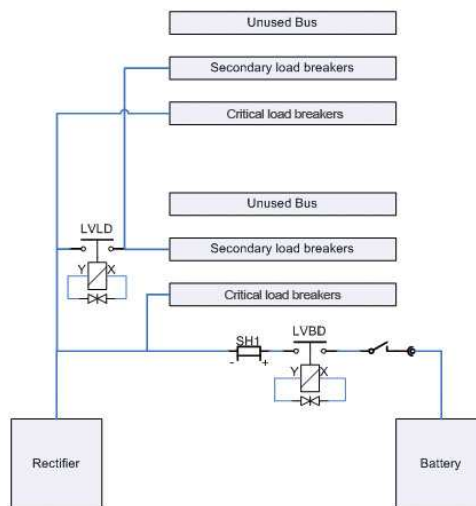

Breaker and Fuse Installation



CAUTION: SIGNIFICANT EXTRACTION FORCE IS REQUIRED TO REMOVE DISTRIBUTION DEVICES DUE TO THE CONTACT PRESSURE REQUIRED FOR HIGHLY RELIABLE, LOW-TEMPERATURE RISE CONNECTIONS.



USE INSULATED TOOLS, ESPECIALLY WHEN WORKING ON LIVE SYSTEMS.

NOTE: Do not use any type of clamps, pliers, or similar tools to remove over-current protection devices as the housing can be cracked by excessive force. Damaged devices represent an operational hazard and should never be used.

Flatpack2 three-bus distributions feature a moveable distribution device holder that accepts a breaker or fuse holder with 5/16" plug-in bullets. It is designed to align the device to one of the three buses by screwing the bottom bullet receptacle directly into the desired bus. A single cable landing on top accepts up to #1 AWG cable with a two-hole 1/4" lug on 5/8" centers. The holder also connects the distribution device to the system alarm circuit.

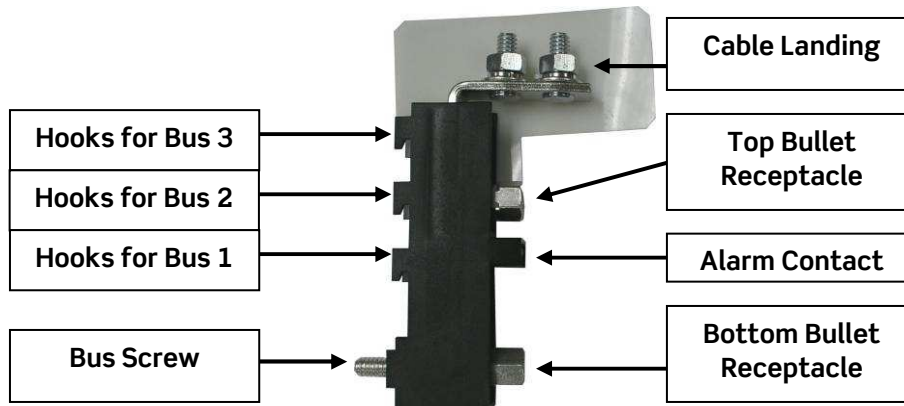

Figure 11 - Distribution Device Holder

NOTE: The distribution device holders must be installed in the desired bus before plugging over-current protection devices into the holders.

NOTE: Breakers and other over-current protection devices must be modified in order to alarm correctly. If using breakers other than those provided by *Eltek Valere*, contact technical support for more information about the modifications necessary for using the breaker/fuse alarming of the three-bus distribution.

Distribution device holders are pre-installed to Bus 3 (the lowest bus) at the factory. To properly access and reassign the distribution device holders refer to Figure 11 and Figure 12 when following these instructions:

- 1) Open the distribution cover using the two thumbscrews.

- 2) Use a Phillips screwdriver to remove the two screws on the front that hold the Lexan cover at the top of the distribution box.
- 3) To remove a device holder, use an insulated 7/16" or 11 mm nut driver to loosen the bottom bullet receptacle of the holder. See Figure 11.
- 4) Select the appropriate bus based on system configuration. Buses are numbered 1 to 3 from top to bottom and are labeled by function on the right and left walls (e.g., "Primary", "Battery", etc.). See the sections on bus configurations beginning on page 16 for details.
- 5) Hook the device holder into the position that lines up with the bus selected in the above step. The holder's hooks (Figure 11) correspond to each bus. **NOTE:** Holders set to higher buses sit higher than those at lower buses. See Figure 10 on page 15.
- 6) Lower the holder into position against the bus.
- 7) Screw the receptacle into the bus using an insulated 7/16" or 11 mm nut driver. Torque between 20 – 25 in-lbs.

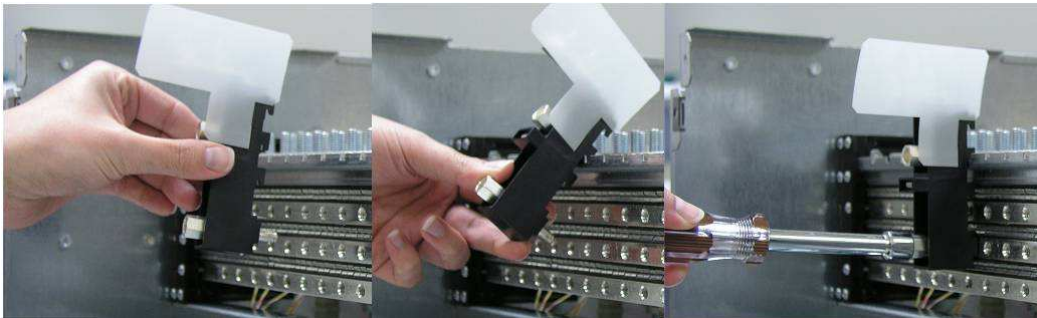

Figure 12 - Distribution Device Holder Installation

To make load connections:

- 1) Make connections with a maximum #1 AWG cable with two-hole lugs having 1/4" diameter holes on 5/8" centers; 1/4"-20 fastening hardware is provided. Do **not** connect batteries until system turn-up.
- 2) Torque connections to 51-58 in-lbs.
- 3) Land each return lug to the corresponding position on the return bus (directly behind the load buses). Return landings are closer together than the output landings and are offset to the right.
- 4) Make a note for each position on the label provided on the distribution door.



Figure 14 - Configurable Protected Load Connections

Plug-in Breakers

Auxiliary contact circuit breakers are the standard over-current protection devices used in the distribution section. Breakers are connected to system alarming through the holder so that an open breaker (whether tripped or manually placed in the OFF position) triggers a “Load Distribution Alarm” in the *Smartpack* controller. Breakers should be removed from any unused positions to prevent nuisance alarms. Single-pole circuit breakers rated up to 100A can be installed. Straps are available to make use of two-pole breakers rated up to 175A and three-pole breakers rated up to 250A.

Plug-in Fuse Holders

Plug-in fuse modules may also be installed. The same considerations regarding insertion and removal of breakers should be observed.

A plug-in fuse assembly consists of three main parts: A fuse, an alarm fuse indicator, and a plug-in module. If the main fuse element opens, the alarming fuse also opens, giving a visible indication of a fault condition; a signal is then sent via the *Smartpack* alarm board that activates the remote system monitor. The alarming fuse must be replaced whenever a new main fuse is required. A fuse holder may be removed and inserted into the plug-in module at any time; it is not necessary to remove the plug-in module to replace the fuse.

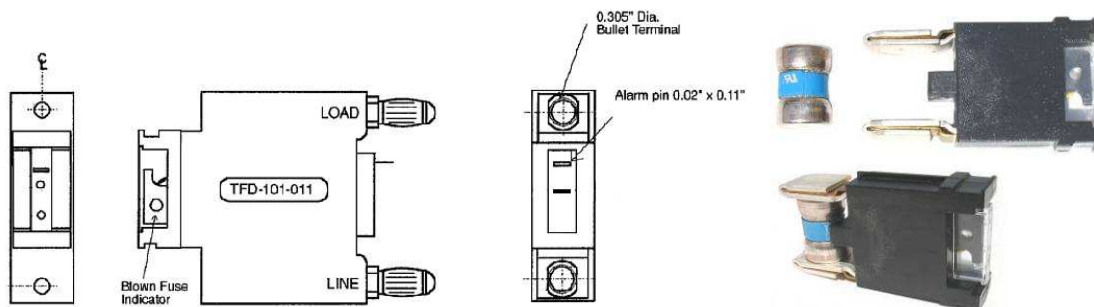

Device Installation and Extraction

To install plug-in breakers or fuse-holders in device holder:

- 1) Remove fuses and turn breaker actuators OFF until system turn-up.
- 2) Orient the device correctly to the device holder (line is the bottom receptacle, load is the top); securely insert device into the receptacles.

A distribution device extraction tool is installed on the distribution door. It is shaped like a handle and has two Phillips-head screws. This item is provided for convenience and should not be necessary for all extractions.

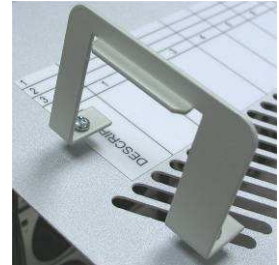

To remove plug-in breakers or fuse-holders:

- 1) Align the extraction tool to the device to be removed.
- 2) Use a Phillips screwdriver to secure the device.
- 3) Firmly pull the device out from the holder. Avoid using excessive force or motion to extract an over-current protection device.



Bulk Distributions



CAUTION: IT IS STRONGLY RECOMMENDED THAT EXTERNAL BREAKERS OR FUSES BE INSTALLED BETWEEN BULK SYSTEM TERMINALS AND EQUIPMENT AND/OR BATTERIES.

A bulk distribution unit is usually a 23" section that features large, front-access copper buses. Each polarity has two landings that accept up to 535MCM cable with two-hole 3/8" lugs on 1" centers. The recommended torque range is 15 to 23 ft. lbs. When facing the front of the system, the bulk "hot" (output) is the left bus; the bulk return is the right bus.

The rear bulk battery terminal specifications are identical to those of the three-bus distributions. See the discussion of bulk battery connections on page 21 for details.

Bulk Battery Connections



CAUTION: DO NOT CONNECT BATTERIES UNTIL SYSTEM TURN-UP. FOLLOW THE CHECKLIST PROVIDED FOR THE PROPER PROCEDURE.



CAUTION: IT IS STRONGLY RECOMMENDED THAT EXTERNAL BREAKERS OR FUSES BE INSTALLED BETWEEN BULK SYSTEM TERMINALS AND BATTERIES.

NOTE: UNFASTENING THE HARDWARE MARKED "DO NOT REMOVE" IN THE FIGURES WILL DISCONNECT THE RETURN BUS FROM THE INTERNAL SYSTEM BUS WORK.

Flatpack2 distributions feature multiple battery termination points at the rear. Landings accept two-hole 3/8"-16 lugs on 1" centers. Each distribution unit has different specifications for cable landings, as follows:

- 19" 4U: Four landings per polarity; maximum wire size of 250 MCM
- 23" 4U: Eight landings per polarity; maximum wire size of 250 MCM
- 23" 6U: Eight landings per polarity; maximum wire size of 750 MCM

Bulk battery return buses contain an extra landing as a central office (CO) ground; see the section on CO Ground on page 25. Carefully examine the figures on page 26 to determine which hardware on the return bus fastens it to the internal system return bus; take care not to disconnect the return bus.

To make connections to battery landings:

- 1) After successful system turn-up, remove the four screws holding the rear cover in place.
- 2) Make connections using two-hole, 3/8"-16 lugs on 1" centers. Fastening hardware is provided.
- 3) Torque connections from 15 to 23 ft.-lbs.

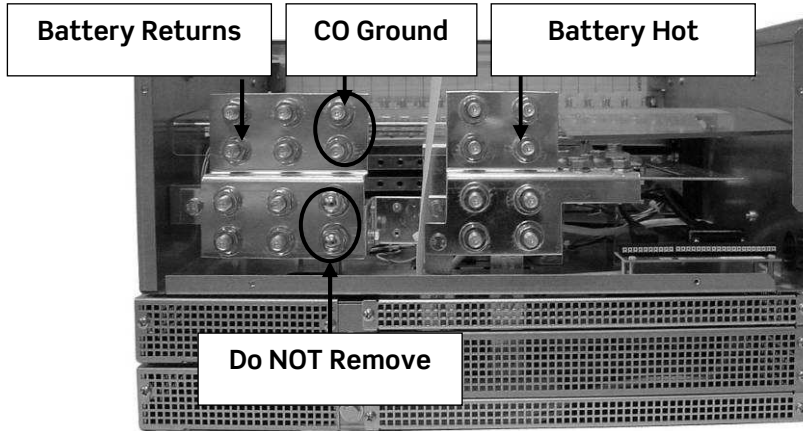

Figure 15 - Bulk Battery Landings (19" Distribution)

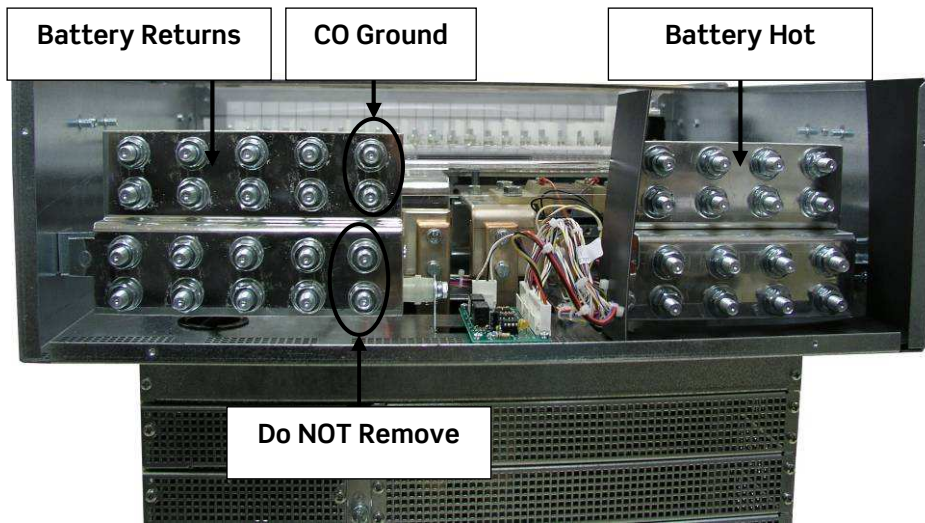

Figure 16 - Bulk Battery Landings (23" 4U Distribution)

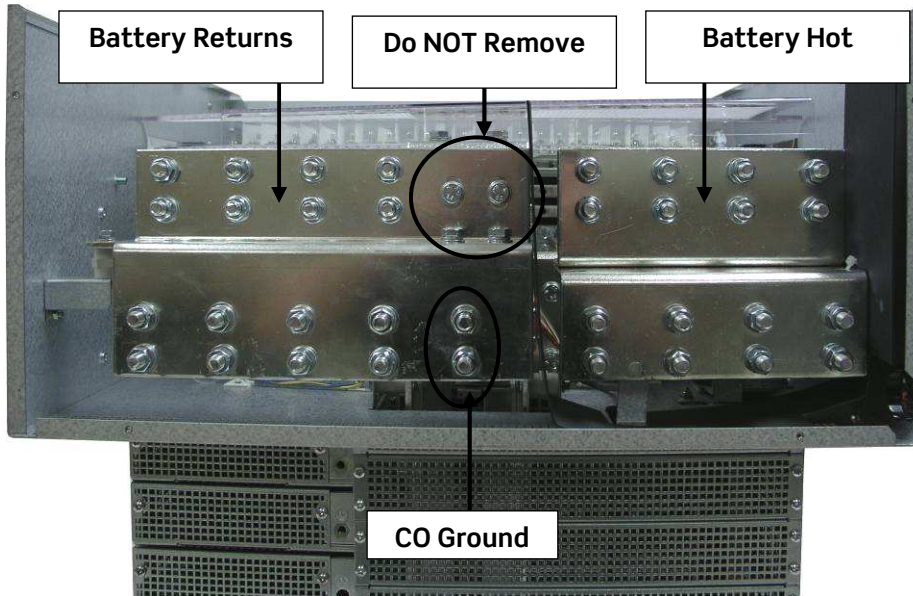

Figure 17 - Bulk Battery Landings (23" 6U Distribution)

Central Office Ground

A dedicated central office (CO) grounding conductor connection is recommended. This conductor should be of the same or larger gauge than the largest system conductor so that it can discharge total system current in a fault condition. A THHN-style cable is recommended. Install this cable between the DC system point and the critical site ground bar. See the figures on page 26 for the recommended organization of return connections.

Other Features and Options

Distribution Covers

Internal Cover

There are two protective covers supplied with the power system. The lower internal cover is positioned just behind the primary return bus bar, and is intended to protect the internal bus structure & contactors. This cover can be removed by loosening the four screws securing it in position with two on either side. Permanent removal of this cover is not recommended, and may impact the safety ratings of the device.

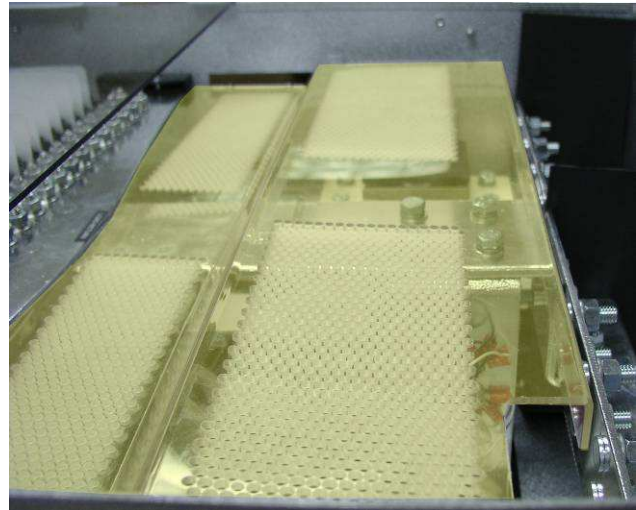

Top Cover

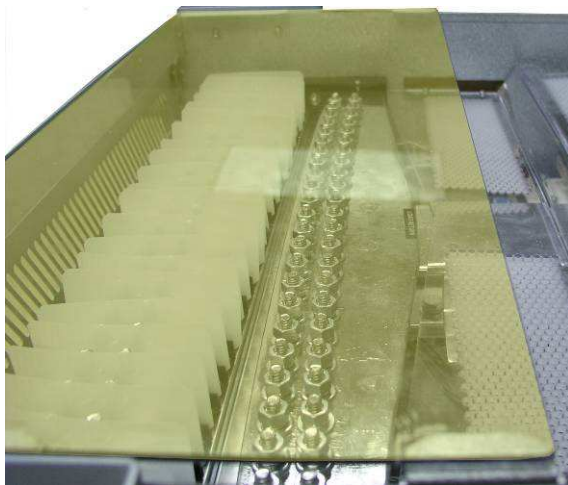

The second cover is positioned above the main distribution section, and is intended to protect the DC load termination points. The cover should be removed during the installation of load wiring. Once wiring is complete it is recommended to replace the cover during long term use. This cover is removed by opening the front door of the system and loosening the two screws securing the cover one on either side.

Emergency Power-Off (EPO) and Service Bypass Switch

The emergency power-off circuit and service bypass switch are situated on a front-access circuit board inside the 23" distribution units. In the 23" 4U distribution, the board is located on the far left; in the 23" 6U, the board is near the center of the distribution unit, just to the left of the controller slots. EPO and service bypass are not available in 19" distributions.

The emergency power-off circuit is a normally-closed circuit that stops system operation when opened. This feature is useful for fires or other emergencies requiring the immediate shut-off of a power system. A jumper wire is provided to keep the circuit closed. If desired, an external emergency device (such as a switch or lever) may be wired to this connection.



Figure 19 - EPO and Service Bypass Switch in 23" 6U Distribution

The service bypass switch forces the LVD contactor to remain closed, preventing service disruption during maintenance. In the "Normal" position (DOWN in the 23" 4U, UP in the 23" 6U), the contactor operates according to the settings defined in the *Smartpack* controller. To activate the bypass, change the switch to "Bypass" (UP in the 23" 4U, DOWN in the 23" 6U); this forces the LVD contactor to close and prevents controller signals from opening it. A label is provided on the inside of the distribution door to illustrate proper switch operation.

Additionally, the LED on the board illuminates when the bypass is active.



Figure 18 - EPO and Service Bypass Switch in 23" 6U Distribution

LVD Options

Up to two low-voltage disconnect (LVD) contactors can be installed. Contactor settings are configured through the *Smartpack* controller.

8. Alarm and Control Terminations

Alarm Contacts

Alarm interface boards differ in location depending on the distribution unit used. The 19" 4U distribution has a single rear-access board located to the far right (when viewed from the rear) next to the bulk battery hot bus. The 23" 4U distribution does not contain alarm boards; rather, a 1U alarm and controller section installed between the distribution and power shelves houses up to two front-access boards (depending on the number of *Smartpack* controllers used), just to the left of the controller slots. The 23" 6U distribution contains front-access boards just to the left of the integrated controller slots.

The alarm interface board provides an equal number of configurable input alarms and form-C output relays. The *Smartpack Extended* version has **six** input alarms and **six** output relays; the *Smartpack Web* has **two** inputs and outputs.

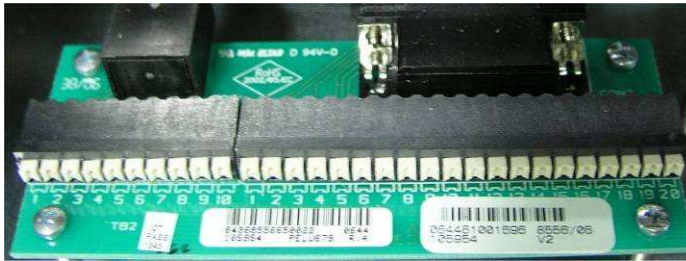

TB2										TB1																			
1	2	3	4	5	6	7	8	9	10	1	2	3	4	5	6	7	8	9	10	11	12	13	14	15	16	17	18	19	20
Conf. input 1B +	Conf. input 1A -	Conf. input 2B +	Conf. input 2A -	Relay 1 OTA	Relay 1 COM	Relay 1 CTA	Relay 2 OTA	Relay 2 COM	Relay 2 CTA	Conf. input 3B +	Conf. input 3A -	Conf. input 4B +	Conf. input 4A -	Conf. input 5B +	Conf. input 5A -	Conf. input 6B +	Conf. input 6A -	Relay 3 OTA	Relay 3 COM	Relay 3 CTA	Relay 4 OTA	Relay 4 COM	Relay 4 CTA	Relay 5 OTA	Relay 5 COM	Relay 5 CTA	Relay 6 OTA	Relay 6 COM	Relay 6 CTA

CTA=CLOSE TO ALARM OTA=OPEN TO ALARM

Relay	Description
1	Common Alarm
2	AC Main Alarm
3	Distribution Alarm
4	High Voltage Alarm
5	Low Voltage Alarm
6	Rectifier Fail Alarm

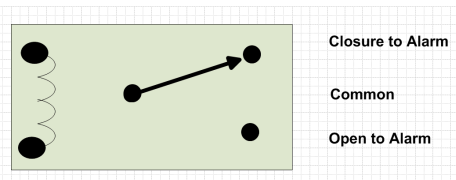

To install an alarm wire to the board:

- 1) Strip the alarm wire end 3/8".
- 2) Press the white terminal clamp above the desired wire location.
- 3) Insert the alarm wire, and release the terminal clamp.

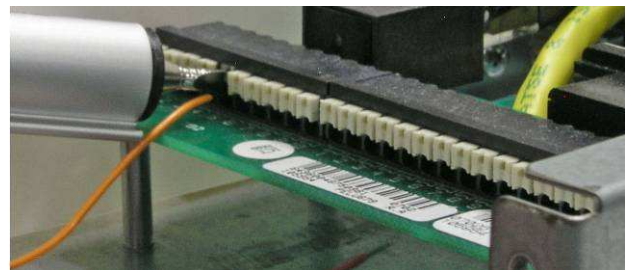

Alarm terminals are designed to accept a wire range of #26 AWG solid or stranded to #18 AWG. The Form-C contacts provided in the system have a rating of 1A at 60 VDC. Please refer to the *User's Guide—Smartpack Monitoring & Ctrl Unit* for further details of alarm relay designations and assignment procedures.

Configurable Inputs

The configurable alarm inputs of the *Smartpack* alarm board can be used to connect external site alarms or input devices such as door sensors, fire alarms, and generator activation alarms. Each relay circuit can be set to “normally-closed” or “normally-open”. This can be selected through either the menu or the *PowerSuite* interface. Some inputs can be used by auxiliary system components like external or tray-mounted battery disconnects and DC-DC converter alarms. Use solid or stranded wire of size 28-16 AWG.

TB2										TB1																			
1	2	3	4	5	6	7	8	9	10	1	2	3	4	5	6	7	8	9	10	11	12	13	14	15	16	17	18	19	20
Conf. input 1B +	Conf. input 1A -	Conf. input 2B +	Conf. input 2A -	Relay 1 OTA	Relay 1 COM	Relay 1 CTA	Relay 2 OTA	Relay 2 COM	Relay 2 CTA	Conf. input 3B +	Conf. input 3A -	Conf. input 4B +	Conf. input 4A -	Conf. input 5B +	Conf. input 5A -	Conf. input 6B +	Conf. input 6A -	Relay 3 OTA	Relay 3 COM	Relay 3 CTA	Relay 4 OTA	Relay 4 COM	Relay 4 CTA	Relay 5 OTA	Relay 5 COM	Relay 5 CTA	Relay 6 OTA	Relay 6 COM	Relay 6 CTA

CTA=CLOSE TO ALARM OTA=OPEN TO ALARM

Temperature Probe Terminations

The standard *Smartpack* controller is capable of temperature-compensated battery charging, symmetry monitoring, and advanced battery discharge monitoring. Temperature probes can be connected directly to the controller or integrated into symmetry monitoring cables.

Rear access to the system controller is required in order to connect a single temperature probe. Unlock the *Smartpack* controller using the same process used for the rectifiers (see page 14). Feed the cable through the system as desired through the wiring ports.

The 15-pin serial connector (DE15) of the temperature probe connects to either **CON3** or **CON4** on the rear of the *Smartpack* controller.

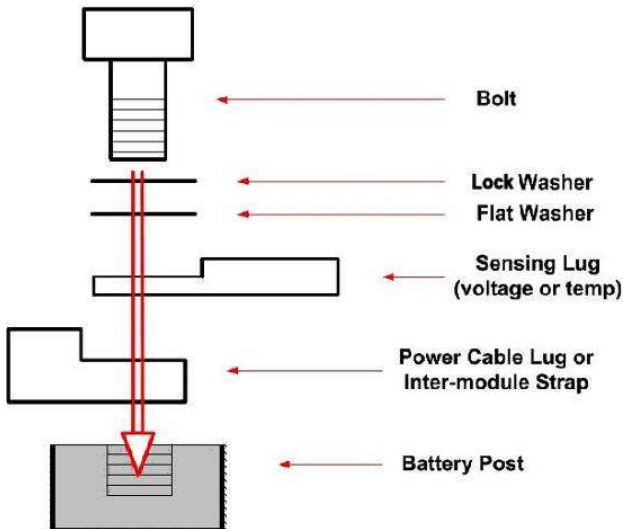

The probe end is designed to be installed directly at the battery post. The best termination point may vary depending on the type of battery used. The probe itself is not polarity sensitive, so it can be installed at either a (-) or (+) battery post. The hardware configuration at left is recommended. This allows the probe to monitor the temperature accurately without interfering with the current-carrying terminations on the battery.

NOTE: IF USING EXTERNAL BATTERY CONNECTIONS BOARDS, SUCH AS THOSE PROVIDED WITH A SYMMETRY MONITORING KIT, DO NOT CONNECT MORE THAN ONE TEMPERATURE PROBE TO EACH OF THE BOARDS. CONNECT A SINGLE PROBE EITHER TO THE 15-PIN SERIAL PORT **CON6/CON7** OR TO THE SENSE INPUTS TO TERMINALS **9** AND **10** OF THE TERMINAL BLOCK.

Symmetry Terminations

Symmetry capability is facilitated by a symmetry monitoring kit. A battery connection board is mounted near the batteries using a bracket. The serial port connector (DE15) connects the board to either **CON3** or **CON4** on the rear of the *Smartpack* controller. Up to two battery boards may be installed for each controller. In this case, temperature probes must connect to the battery connection board (one per board). Battery symmetry harness connections will vary depending on the desired configuration. Refer to the symmetry kit manual (#251491.033) for more details and installation instructions.

9. Controller Access

Controller Configurations

The *Flatpack2* power system can be delivered in several configurations. The following examples are basic configurations. The *300A* power systems use a single *Smartpack* controller; the *600A* and *1200A* systems permit the use of a master-slave configuration for up to two controllers.

Smartpack Extended

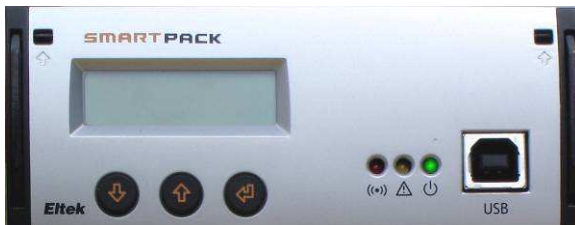

- Local user interface via a three-button keypad on the front panel
- 2 line x 16 character, high-contrast backlit LCD display
- Digital communication with each *Flatpack2* rectifier
- Storage of setup parameters, alarm configuration and system history in non-volatile memory
- Real time clock with battery backup
- Advanced battery monitoring and *full symmetry for 2 battery strings*
- Recording of rectifier serial numbers and other information
- Load-shedding control
- 6 digital inputs* for site equipment alarms
- 6 user defined* form C output contacts

Smartpack Extended with Slave



- Local user interface via a three-button keypad on the front panel
- 2 line x 16 character, high-contrast backlit LCD display
- Digital communication with each *Flatpack2* rectifier
- Storage of setup parameters, alarm configuration and system history in non-volatile memory
- Real time clock with battery backup
- Advanced battery monitoring and *full symmetry for 4 battery strings*
- Recording of rectifier serial numbers and other information
- Load-shedding control
- 12 digital inputs* for site equipment alarms
- 12 user defined* form C output contacts

Smartpack Web



- Local user interface via a three-button keypad on the front panel
- 2 line x 16 character, high-contrast backlit LCD display
- Digital communication with each *Flatpack2* rectifier – *TCP / IP or SNMP user interface*
- Storage of setup parameters, alarm configuration and system history in non-volatile memory
- Real time clock with battery backup
- Advanced battery monitoring and *full symmetry for 2 battery strings*
- Recording of rectifier serial numbers and other information
- Load-shedding control
- 2 digital inputs* for site equipment alarms
- 2 user defined* form C output contacts

Smartpack Web with Slave



- Local user interface via a three-button keypad on the front panel
- 2 line x 16 character, high-contrast backlit LCD display
- Digital communication with each *Flatpack2* rectifier – *TCP / IP or SNMP user interface*
- Storage of setup parameters, alarm configuration and system history in non-volatile memory
- Real time clock with battery backup
- Advanced battery monitoring and *full symmetry for 4 battery strings*
- Recording of rectifier serial numbers and other information
- Load-shedding control
- 8 digital inputs* for site equipment alarms
- 8 user defined* form C output contacts

Smartpack with Controller Blank

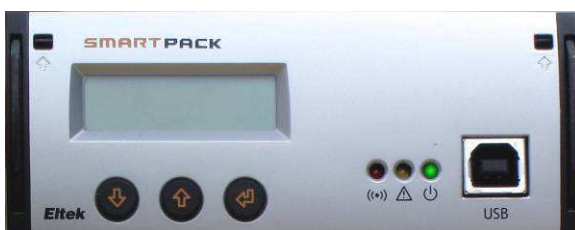

Because the 600A and 1200A *Flatpack2* systems can accommodate up to two *Smartpack* controllers, a blank faceplate may be installed if the expansion slot is not populated.





Local Keypad Access

The *Smartpack* controller is typically pre-configured at the factory according to customer requirements. If operational adjustments are required refer to the *PowerSuite* Help menu or *Smartpack* manual for further details. The *Smartpack* digital controller is located in the distribution section and provides system control and monitoring functions. Features include:

- Local user interface via a three-button keypad on the front panel
- 2 line x 16 character, high-contrast backlit LCD display
- Digital Communication over CAN-bus with each Flatpack2 rectifier
- Storage of setup parameters, alarm configuration and system history in non-volatile memory
- Real time clock with battery backup
- Advanced battery monitoring and protection



Display Modes: *Status Mode* (displays the system's status) or *Menu Mode* (displays the menu structure).

Operation: Press the  key to change from *Status Mode* to *Menu Mode*. Press the  or  keys to scroll up or down and navigate to find menu options (function or parameter). Press the  key to select functions.

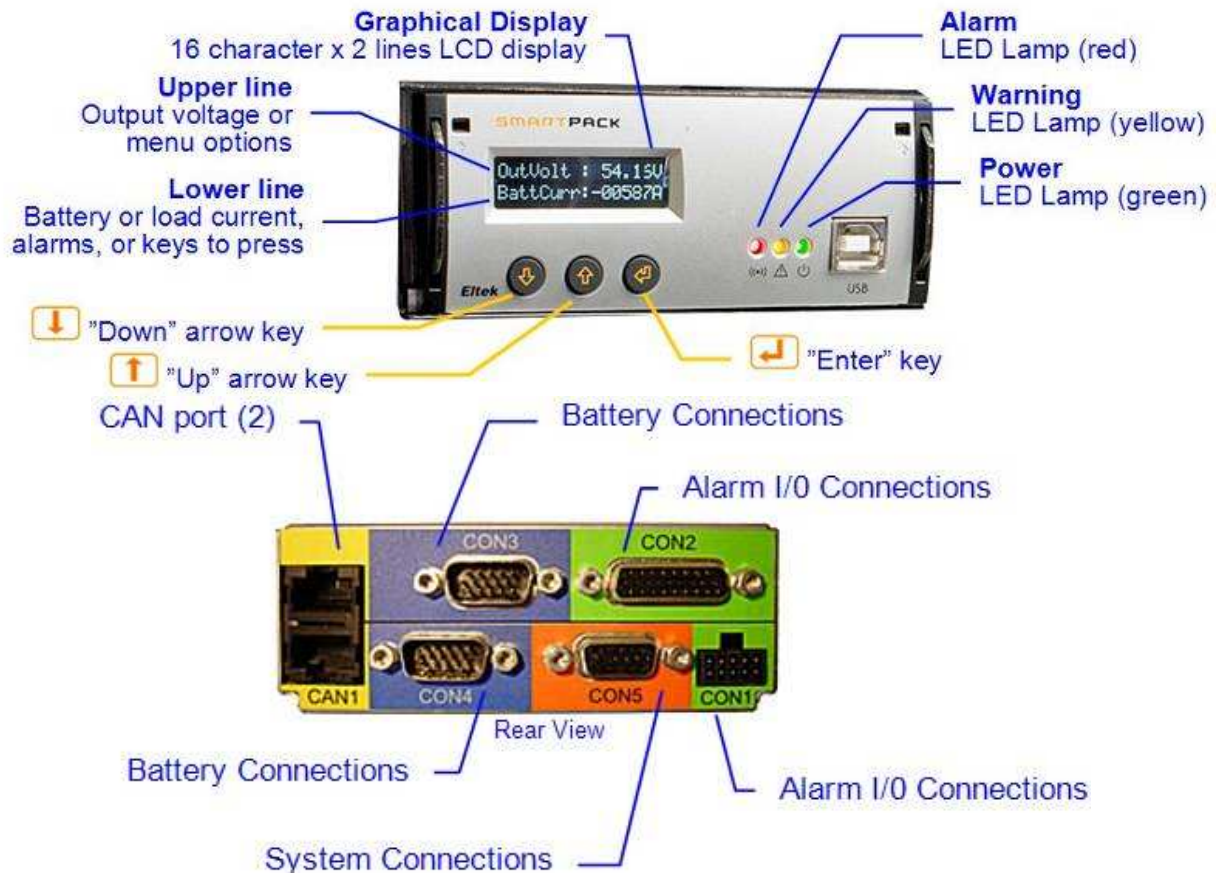

Adjustment Menu Example:

	NomVolt	↓↑
	BoostVolt	↓↑
	LoBattMaj	↓↑
Volt Adjustment →	LoBattMin	↓↑
	HiBattMaj	↓↑
	HiBattMin	↓↑
	LVBD	↓↑
	LVL1.1	↓↑
Volt Calibration →	VoltCal	↓↑
Change Password →	Password	↓↑
Set Boost Time →		↓↑
Start/Stop Boost →		
Auto Boost Conf. →	Enable/Disable	↓↑ & Threshold ↓↑
	Nxt Test Date Time	Date ↓↑ Time ↓↑
	End Volt	↓↑
Batt Test Setup →	MaxTestDur	↓↑
	Test Int	↓↑
	Guard Time	↓↑
Start/Stop Test →		
# Of Rectifiers→	Reset	
Charge Curr Lim. →	Enable/Disable	↓↑ & Max C.Curr ↓↑
Battery Setup →	NumOfString	↓↑
	CellCap Ah nn	↓↑
Output Control →	Voltage Ctrl / Temp Comp	↓
Change Date/Time →	Date	↓↑ Time ↓↑
	Alarm Output 1	↑
Relay Test →	Alarm Output 2	↑
	Batt Contactor	↑
	Load Contactor	↑
	Alarm Output nn	↑

Menus: When entering *Menu Mode* (Level 1), access *User Options*. By default, it is set to “read-only”.

To make changes to the settings, enter the *Service Options* menu and enter the password.

Default password: 0003

When the front keys are not in operation, the display is in *Status Mode*. The upper line continuously displays the battery voltage. The lower line scrolls the following information:

- Battery Current
- Load Current
- Active alarms
- Other messages

Local Computer Access

PowerSuite software must be installed on the PC to be used **before** connecting to the **Smartpack** controller. **Do not** connect USB prior to installation process. In most cases, **FrameNet** (also provided) must be installed prior to **Powersuite**.

Example screen shots:

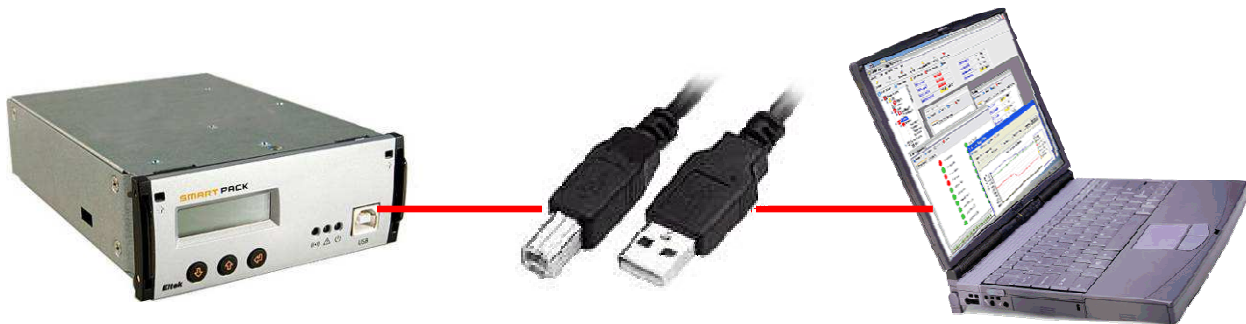
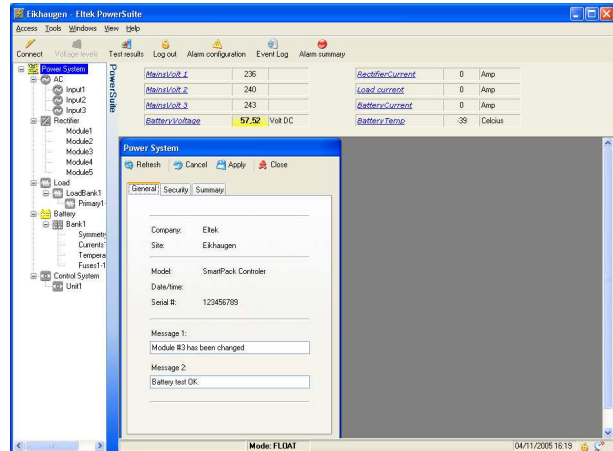
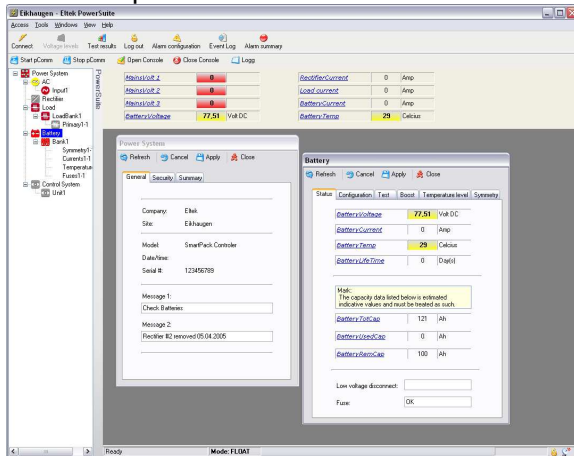

Interface with a PC requires a standard A-B USB cable.

*To make changes to the settings enter the *Service Options* menu **Default password <0003>**

The “Log In” dialog box is displayed by selecting “**Access > Login**” from the menu, pressing the shortcut key **F4**, or using the “Log In” button on the toolbar.

For further info on controller operation and adjustment, refer to the *User’s Guide—Smartpack Monitoring & Ctrl Unit*.

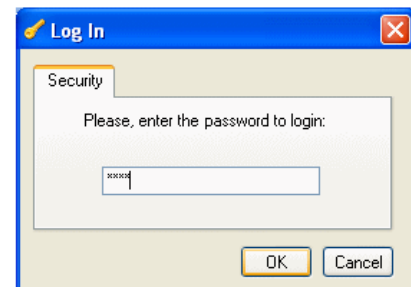

10. Startup Checklists

This section includes basic checklists to assist the user in verifying proper installation and starting system operation.

Pre-Start Check

Power is OFF!

CHECK THE FOLLOWING POINTS:		OK
1. Flatpack2 system installation is completed;	The <i>Flatpack2 Installation Check List</i> is filled in. All cabling is securely terminated with correct polarity	<input type="checkbox"/>
2. All battery and load Breakers / fuses are disconnected		<input type="checkbox"/>
3. AC input cable(s) and AC earth wire (Ground) are terminated		<input type="checkbox"/>
4. Site specific parameters and settings are known		<input type="checkbox"/>
5. AC supply and all Breakers / fuses are switched OFF		<input type="checkbox"/>

Start-up, No-Load & Load Adjustments

Power is ON!

CARRY OUT FOLLOWING:		OK
1. Install all rectifier modules in desired locations		<input type="checkbox"/>
2. Verify AC input voltage is correct;	Measure and verify	<input type="checkbox"/>
3. Switch ON the external AC feeds		<input type="checkbox"/>
4. Verify all rectifier modules are working, Green power LEDs are ON	Verify	<input type="checkbox"/>
5. Verify The <i>Smartpack</i> is functioning Green power LED is ON	Verify	<input type="checkbox"/>
6. Connect a PC to the PS system	Install the <i>PowerSuite</i> software, if required	<input type="checkbox"/>
7. Verify DC output voltage;	Measure and adjust as needed	<input type="checkbox"/>
8. Measure battery voltage, confirm level, and close disconnect if present	Verify correct polarity!	<input type="checkbox"/>
9. Verify System Setup is in accordance with desired configuration	Enter site spec. info in <i>PowerSuite</i>	<input type="checkbox"/>
10. Connect all load Breakers / fuses, and verify no alarms are displayed		<input type="checkbox"/>
11. Verify the rectifiers output current, and load function		<input type="checkbox"/>
12. Verify System Alarm Setup is in accordance with desired configuration	Configure alarm mapping in <i>PowerSuite</i>	<input type="checkbox"/>
13. Use <i>PowerSuite</i> to simulate Alarm Relay conditions	Verify all alarm relays are working correctly	<input type="checkbox"/>
14. This completes the basic system start-up and configuration		<input type="checkbox"/>



www.eltektvalere.com

Headquarters:

Eltek Valere

1303 E. Arapaho Rd, Richardson, TX. 75081, USA

Phone: +1 (469) 330-9100 Fax: +1 (469) 330-9101

Eltek Valere

Gråterudv. 8, Pb 2340 Strømsø, 3003 Drammen, Norway

Phone: +47 32 20 32 00 Fax: +47 32 20 32 10